

REVISION HISTORY			
REV	DATE	BY	DESCRIPTION
E	07MAY2018	RKS/VK	PRN: P2018-1083

IN-LINE KNUCKLE STYLE

PAT. DES. 268,733

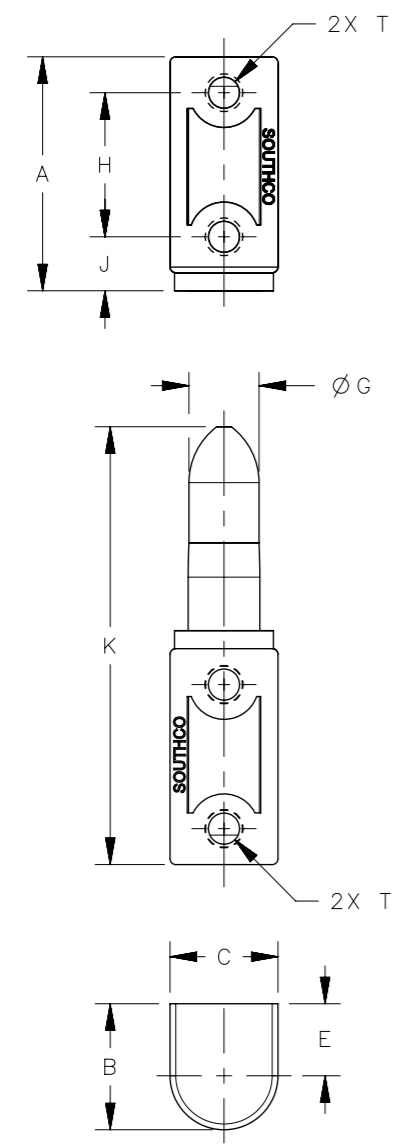

OFFSET KNUCKLE STYLE

PAT. DES. 263,370

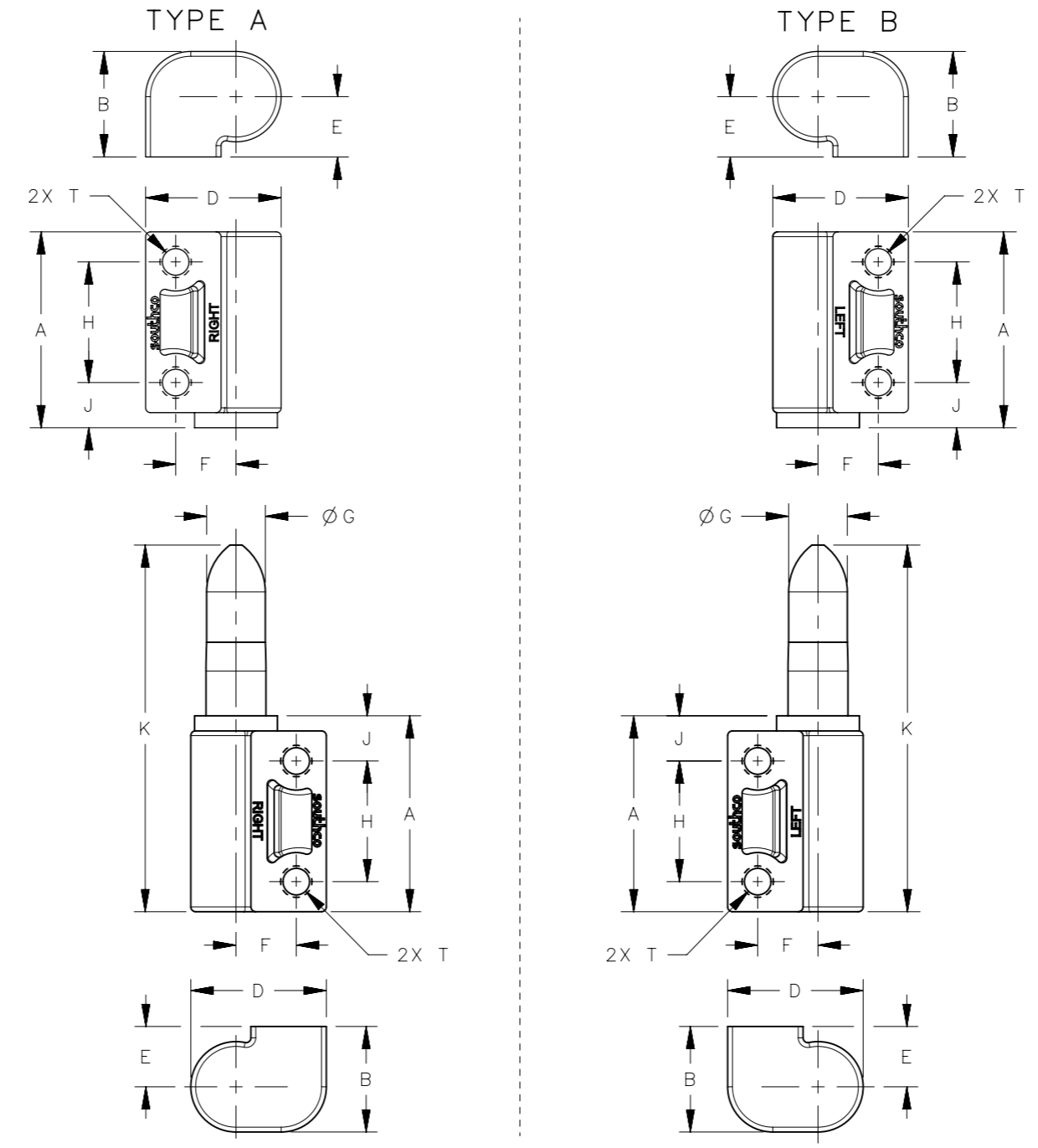

SIZE (SERIES)	ASSEMBLY PART NUMBERS			DIMENSIONS										MOUNTING HOLE THREAD SIZE T
	IN-LINE KNUCKLE STYLE	OFFSET KNUCKLE STYLE		A	B	C	D	E	F	G	H	J	K	
		TYPE A	TYPE B											
300	96-50-300-XX	96-50-310-XX	96-50-320-XX	31	16.7	14.3	21.4	9.5	9.5	9.5	19.1	7.1	57.9	M5 X 0.8
400	96-50-400-XX	96-50-410-XX	96-50-420-XX	41.3	22.2	19.1	28.6	12.7	12.7	12.7	25.4	9.5	77.8	M6 X 1

400	OFFSET (TYPE B)	96-50-420-XX	96-51-420-XX	96-52-420-XX	SEE NOTE 2
400	OFFSET (TYPE A)	96-50-410-XX	96-51-410-XX	96-52-410-XX	
400	IN-LINE	96-50-400-XX	96-51-400-XX	96-52-400-XX	
300	OFFSET (TYPE B)	96-50-320-XX	96-51-320-XX	96-52-320-XX	
300	OFFSET (TYPE A)	96-50-310-XX	96-51-310-XX	96-52-310-XX	
300	IN-LINE	96-50-300-XX	96-51-300-XX	96-52-300-XX	
SERIES	STYLE	ASSEMBLY	PIN/KNUCKLE	KNUCKLE	COLOR

NOTES:

- MATERIAL: THERMOPLASTIC
- XX = COLOR
-11 = BLACK
-12 = WHITE
- A HINGE ASSEMBLY CONSISTS OF ONE HINGE KNUCKLE WITH A PIN AND ONE WITHOUT A PIN.
- MAXIMUM RECOMMENDED TIGHTENING TORQUE FOR MOUNTING SCREWS:
300 SERIES: 2.25Nm
400 SERIES: 4.50Nm

THIRD ANGLE PROJECTION		
MILLIMETERS [IN]		
SURFACE AREA	TOLERANCES UNLESS OTHERWISE NOTED	
VOLUME	ALL DIMENSIONS WITHOUT TOLERANCES ARE FOR REFERENCE ONLY	
PROPRIETARY ITEM	PER ASME Y14.5M-1994	DESCRIPTION: NO. 96 LIFT-OFF HINGES FREE SWINGING - METRIC
EXCEPT FOR USES EXPRESSLY GRANTED IN WRITING, INFORMATION DISCLOSED HEREON IS CONFIDENTIAL AND ALL RIGHTS, PATENT AND OTHERWISE, ARE RESERVED BY SOUTHCO, INC.	SIZE: A3 SYSTEM: NX DWG NO.: J-96-5	SCALE: 1:1 SHEET: 1 OF 1
	DRAWN BY: AJF DATE: 06JUL1983	