

Series 79 Micro-Crimp Connectors and Cables

The Micro-D Connector with Crimp Contacts: Power, Signal and Coax

United States ■ United Kingdom ■ Germany ■ France ■ Nordic ■ Italy ■ Spain ■ Japan

Glenair's World of *Miniaturized* Interconnect Solutions



**Series 80
"Mighty Mouse"
Connectors and Cables**

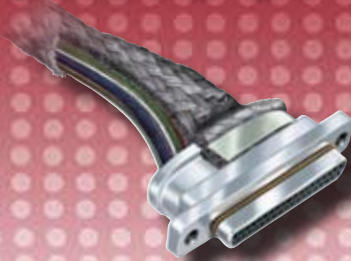

**MIL-DTL-83513
Micro-D
Connectors and Cables**



**MIL-DTL-32139
Nano Miniature
Connectors and Cables**



**Ultra Low-Profile
Composite
Backshells**



**CB Series Compact
Bayonet "PogoPin"
Connectors**



**Glenair High Density
Fiber Optic Connectors
and APC Termini**

High-Performance, Ultra-Miniature Interconnect Systems for Military and Commercial Applications



1211 Air Way
Glendale, California 91201-2497

Telephone: 818-247-6000 · Facsimile: 818-500-9912 · E-mail: sales@glenair.com

United States · United Kingdom · Germany · Nordic · France · Italy · Spain · Japan

www.glenair.com

Series 79 “Micro-Crimp” Connectors

Table of Contents

**Introduction to
the Micro-Crimp**
Pages 4 – 5

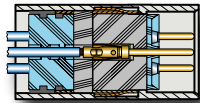

**Insert
Arrangements**
Pages 6 – 9

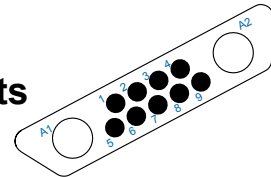

Crimp Contacts
Pages 10 – 13



**Contact
Crimp Tools**
Pages 14 – 17



**Crimp
Connectors
for Cable
Termination**
Pages 18 – 21



**Panel Mount
Connectors,
Crimp
Termination**
Pages 22 – 29



**Panel Mount
Connectors, PCB
Termination**
Pages 30 – 37



Panel Cutouts
Pages 38 – 39

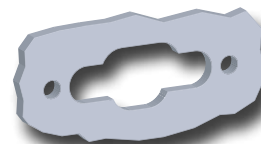

**Product
Specifications**
Pages 41 – 47

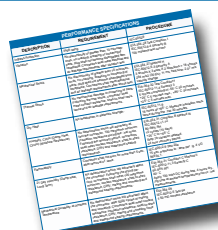

DESCRIPTION	PERFORMANCE SPECIFICATIONS	NOTES
Model 79-100
Model 79-101
Model 79-102
Model 79-103
Model 79-104
Model 79-105
Model 79-106
Model 79-107
Model 79-108
Model 79-109
Model 79-110
Model 79-111
Model 79-112
Model 79-113
Model 79-114
Model 79-115
Model 79-116
Model 79-117
Model 79-118
Model 79-119
Model 79-120

*Plug With Socket
Contacts*



*Receptacle With
Pin Contacts*



Crimp, Rear-Release

M39029 type contacts accept up to #12 AWG wire.

360° EMI Spring

Innovative spring assures excellent shielding performance.

Environmentally Sealed

Fluid-resistant gaskets and seals provide IP67 ingress protection.

Glenair's Series 79 Micro-Crimp Micro-D Connector

Today's defense/aerospace systems require advanced levels of environmental protection, electromagnetic shielding and size/weight reduction. The Series 79 Micro-Crimp connector was created to meet the need for environmental sealing, improved shielding, and reduced size/weight. Available in a wide range of insert arrangements, the Micro-Crimp offers size #12, #16 and #23 contacts. Snap-in rear release signal, power and coaxial contacts meet the requirements of SAE AS39029. Printed circuit board versions complete the product range.

"MICRO-CRIMP" RECEPTACLE

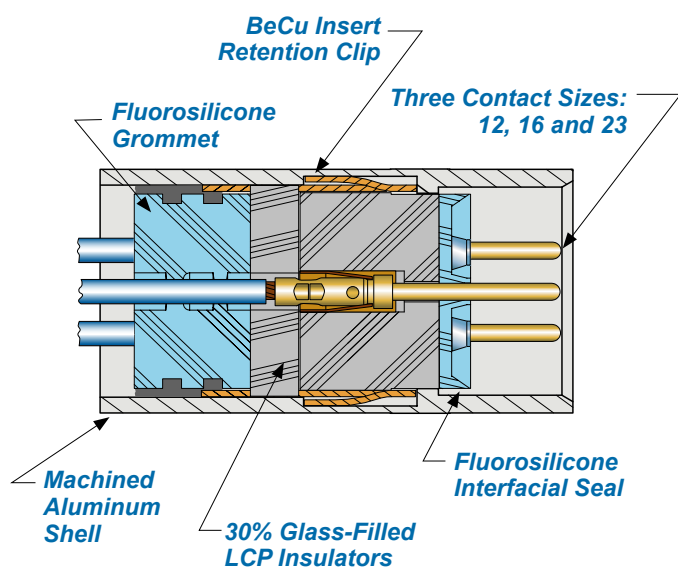

"MICRO-CRIMP" PLUG

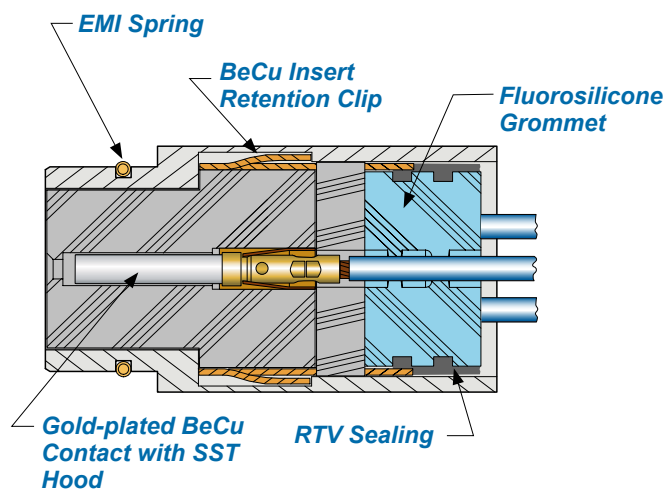

Dimensions in inches (millimeters) and are subject to change without notice.

Series 79 Micro-Crimp Micro-D for Mixed Signal, Power and Coaxial Applications



EMI ADAPTERS



Lightweight, low profile shielding adapters allow direct attachment of cable shields for excellent EMI performance. These two-piece adapters lock into a groove on the connector body.

BLIND MATE CONNECTORS



Micro-Crimp panel mount connectors are ideal for module-to-chassis packaging. Stainless steel guide pins assure connector alignment for blind mate applications. Float bushings are also available.

ENVIRONMENTAL EMI BACKSHELL



This rugged, watertight backshell features screw locks, sealing gasket and direct attachment to the connector.

EMI SPRING

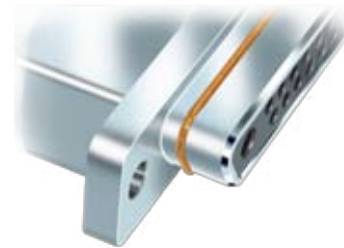

The EMI springs utilized on Glenair Micro-Crimp plug connectors provide 360 degrees of contact with the mating connector. The closely spaced spring coils reduce EMI apertures to a minimum.

PRINTED CIRCUIT BOARD

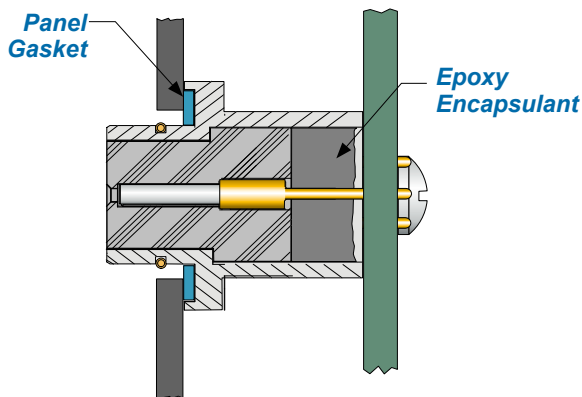

PANEL GASKET

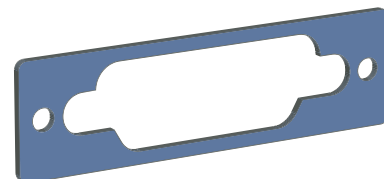

Conductive Rubber Gaskets: Panel mount Micro-Crimp connectors are furnished with gaskets made from Chomerics CHO-SEAL 1287 fluorosilicone filled with silver-plated aluminum. These gaskets provide excellent resistance to avionics fluids and low resistivity.

Dimensions in inches (millimeters) and are subject to change without notice.

Insert Arrangements Explained

The first letter represents the shell size. The number following the shell size represents the total number of contacts. If the insert arrangement is a mixed layout with signal contacts and coaxial/power contacts, the letter "W" specifies the connector to be furnished with signal contacts only (coax/power contacts purchased separately), and the letter "P" specifies the connector to be furnished with both signal and power contacts.

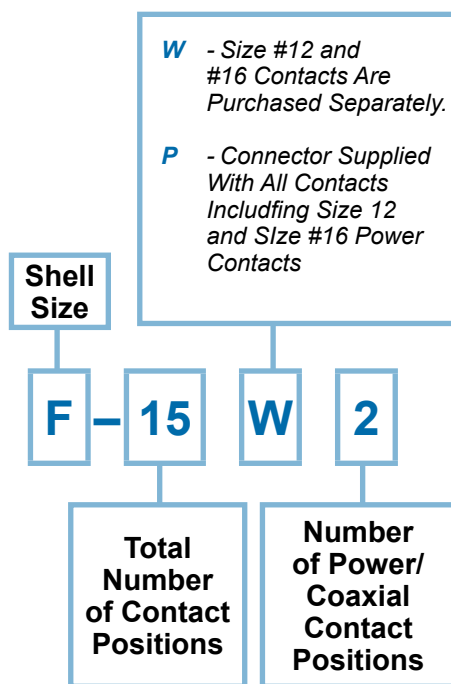

MICRO-CRIMP INSERT ARRANGEMENTS					
Shell Size	Full Complement of Contacts	#12 and #16 Contacts Purchased Separately	Contact Quantity		
			#23	#16	#12
A	A-5		5		
B	B-2P2	B-2W2		2	
	B-9		9		
C	C-13		13		
D	D-15		15		
	D-3P3	D-3W3		3	
	D-7P2	D-7W2	5	2	
E	E-11P2	E-11W2	9	2	
	E-19		19		
	E-7P3	E-7W3	4	3	
F	F-15P2	F-15W2	13	2	
	F-23		23		
	F-5P5	F-5W5		5	
G	G-33		33		
H	H-10P4	H-10W4	6		4
	H-29P7	H-29W7	22	7	
	H-36P2	H-36W2	34		2
	H-54P2	H-54W2	52	2	
	H-5P5	H-5W5			5
	H-66		66		
J	J-17P4	J-17W4	13	4	
	J-25P2	J-25W2	23	2	
	J-33		33		
	J-7P7	J-7W7		7	
K	K-27P4	K-27W4	23	4	
	K-35P2	K-35W2	33	2	
	K-43		43		
	K-9P9	K-9W9		9	
L	L-6P6	L-6W6			6

Dimensions in inches (millimeters) and are subject to change without notice.

Series 79 Micro-Crimp Micro-D for Mixed Signal, Power and Coaxial Applications



MICRO-CRIMP INSERT ARRANGEMENTS			
Shell Size	Insert Arr.	No. of Contacts and Contact Size	Mating Face Pin Connector
A	A-5	5 #23 CONTACTS	
B	B-2P2 B-2W2	2 #16 CONTACTS	
B	B-9	9 #23 CONTACTS	
C	C-13	13 #23 CONTACTS	
D	D-15	15 #23 CONTACTS	
D	D-3P3 D-3W3	3 #16 CONTACTS	
D	D-7P2 D-7W2	5 #23 CONTACTS 2 #16 CONTACTS	
E	E-11P2 E-11W2	9 #23 CONTACTS 2 #16 CONTACTS	
E	E-19	19 #23 CONTACTS	
E	E-7P3	4 #23 CONTACTS 3 #16 CONTACTS	
F	F-15P2 F-15W2	13 #23 CONTACTS 2 #16 CONTACTS	
F	F-23	23 #23 CONTACTS	
F	F-5P5 F-5W5	5 #16 CONTACTS	
G	G-33	33 #23 CONTACTS	

Dimensions in inches (millimeters) and are subject to change without notice.

Series 79 Micro-Crimp Micro-D for Mixed Signal, Power and Coaxial Applications

MICRO-CRIMP INSERT ARRANGEMENTS			
Shell Size	Insert Arr.	No. of Contacts and Contact Size	Mating Face Pin Connector
H	H-10P4 H-10W4	6 #23 CONTACTS 4 #12 CONTACTS	
H	H-29P7	22 #23 CONTACTS 7 #16 CONTACTS	
H	H-36P2 H-36W2	34 #23 CONTACTS 2 #12 CONTACTS	
H	H-54P2 H-54W2	52 #23 CONTACTS 2 #16 CONTACTS	
H	H-5P5 H-5W5	5 #12 CONTACTS	
H	H-66	66 #23 CONTACTS	
J	J-17P4 J-17W4	13 #23 CONTACTS 4 #16 CONTACTS	
J	J-25P2 J-25W2	23 #23 CONTACTS 2 #16 CONTACTS	
J	J-33	33 #23 CONTACTS	

Dimensions in inches (millimeters) and are subject to change without notice.

Series 79 Micro-Crimp Micro-D for Mixed Signal, Power and Coaxial Applications



MICRO-CRIMP INSERT ARRANGEMENTS			
Shell Size	Insert Arr.	No. of Contacts and Contact Size	Mating Face Pin Connector
J	J-7P7 J-7W7	7 #16 CONTACTS	
K	K-27P4 K-27W4	25 #23 CONTACTS 4 #16 CONTACTS	
K	K-35P2 K-35W2	33 #23 CONTACTS 2 #16 CONTACTS	
K	K-43	43 #23 CONTACTS	
K	K-9P9 K-9W9	9 #16 CONTACTS	
L	L-6P6 L-6W6	6 #12 CONTACTS	

Dimensions in inches (millimeters) and are subject to change without notice.

Size #23 Beryllium Copper Crimp Contacts

Standard size #23 contacts accept #22 to #28 AWG wire. Choose "small bore" versions for #26 to #30 AWG wire. For thermocouple applications, specify alumel or chromel contacts. Contacts are bulk packaged. Terminate with standard M22520 crimper with special positioner.

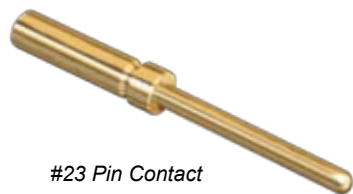

#23 Pin Contact



#23 Socket Contact

Contact Type	Wire Size	Material	Part Number	Ø A		Color Band	Tool Code
				In.	mm.		
Pin	#22 - #28	BeCu	809-001	.0335-.0355	0.851-0.902	None	A
Pin	#26 - #30	BeCu	809-042	.0229-.0245	0.582-0.622	Blue	B
Pin	#22 - #28	Alumel	809-065A	.0335-.0355	0.851-0.902	None	A
Pin	#22 - #28	Chromel	809-065C	.0335-.0355	0.851-0.902	None	A
Socket	#22 - #28	BeCu	809-002	.0335-.0355	0.851-0.902	None	A
Socket	#26 - #30	BeCu	809-043	.0229-.0245	0.582-0.622	Blue	B
Socket	#22 - #28	Alumel	809-066A	.0335-.0355	0.851-0.902	None	A
Socket	#22 - #28	Chromel	809-066C	.0335-.0355	0.851-0.902	None	A

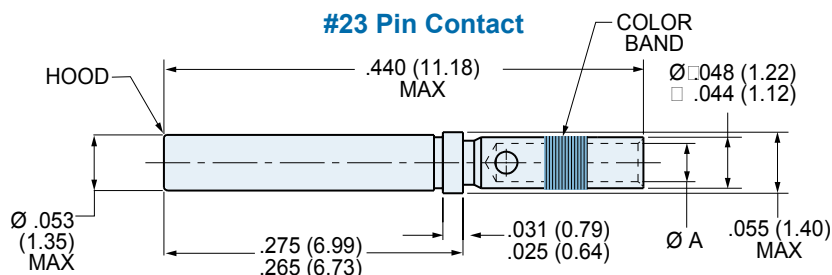
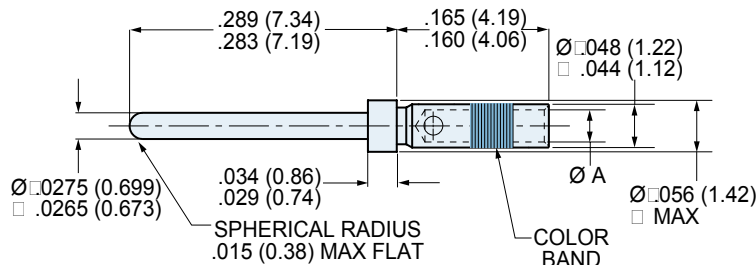

#23 Socket Contact

CRIMP TENSILE STRENGTH

Wire Gage	Silver or Tin Coated Copper Wire	Nickel Coated Copper Wire
#22	12	8
#24	8	6
#26	5	3
#28	3	2
#30	1.5	1.5

Material and Finish

Beryllium copper alloy per ASTM B196 or B197, 50 microinches gold plated per ASTM B488 Type 3 Code C Class 1,27 over nickel plate per QQ-N-290 Class 2, 50-100 microinches. Thermocouple contacts: alumel or chromel alloy, unplated, per ANSI 96.1. Socket contact hood: stainless steel, passivated per AMS-QQ-P-35.

Specifications

Current Rating: 5 Amps maximum
 Voltage Drop (at 5 Amps and 25° C): 70 millivolts maximum
 Temperature Range: -65° to + 200° C
 Socket Contact Minimum Separation Force: 0.5 ounces

Crimp Tools and Insertion/Removal Tools

Crimper: 809-015
 Positioner: 809-005 (standard). Use P/N 809-057 for small bore contacts 809-065 and 809-066
 Standard Insertion/Removal Tool: 809-088
 Tweezer Type Metal Extraction Tool: 809-007

Dimensions in inches (millimeters) and are subject to change without notice.

CAGE Code 06324

Printed in U.S.A.

How To Terminate, Install and Remove Size #23 Contacts

1 Set Up Crimp Tool. Install proper positioner into crimp tool. The label on the positioner shows the proper tool setting for each wire size. Turn the adjustment wheel to the correct setting.

2 Strip Wire. Remove wire insulation, taking care to avoid nicking or cutting wire strands. Strip wire to length shown.

3 Insert wire into contact. The wire should be visible in the inspection hole.

4 Insert contact into crimp tool as shown. Make sure that the contact is fully inserted into the tool. Squeeze handle completely. The ratchet mechanism will not allow a partial crimp. Release handle and remove contact.

5 Inspect crimped contact. Wire should be fully inserted and the crimp should be uniform in appearance.

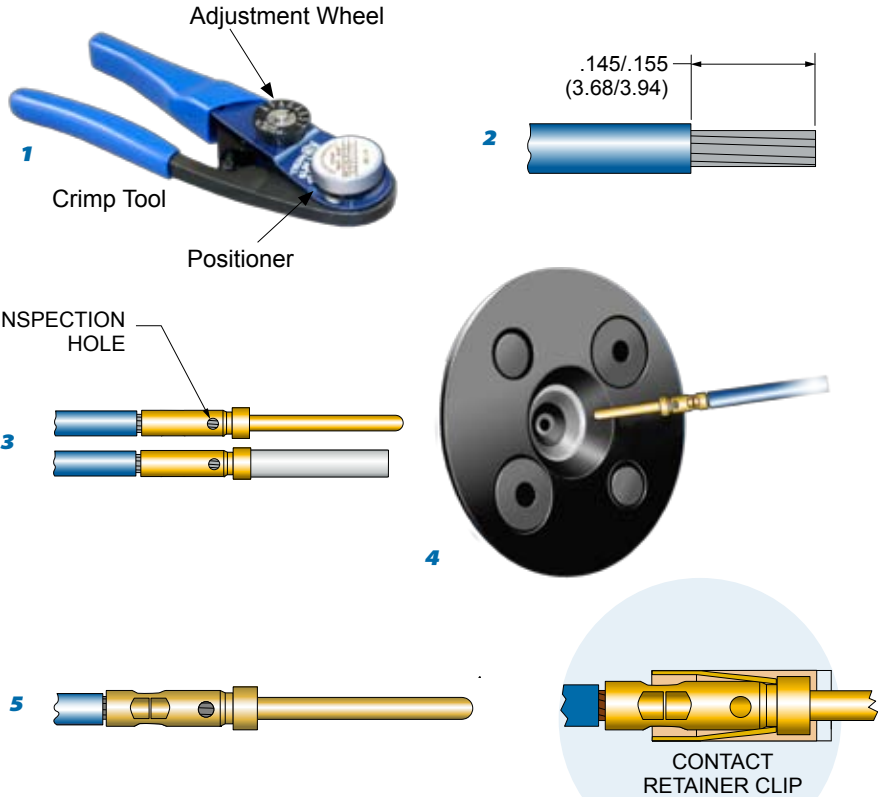

Insertion/Extraction Tool 809-088

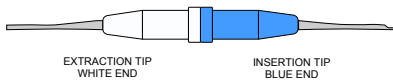

6 Install contact into connector. Push the contact through the rear grommet until the contact locks into place. This can usually be done by hand without the need for a tool. If the wire gage is #26 or smaller, a tool is helpful. There are two techniques for installing contacts with a tool. One method is to push the contact in by hand, then use the tool to finish the insertion. The other method is to position the insertion tip against the contact shoulder, then insert the contact. Use insertion/extraction tool 809-088 to install contacts. Slide the wire into the groove on the blue end of the tool. Slide the tool tip up the contact until it touches the contact shoulder. **USE CARE TO AVOID DAMAGING THE CONNECTOR.**

7 Contact Extraction. Use tool 809-088. The white end is used for contact extraction. First, push the wire into the groove of the metal tip. Slide the tip of the tool into the connector. Push the tool into the connector cavity until the tip bottoms in the connector. Avoid wiggling or rocking the tip. This may damage the cavity. A straight push is best. Pinch the wire between your finger and the white plastic grip and slide the tool and contact out of the connector. **Wire insulation diameter greater than 0.045 inches (1.14mm) is too large to work properly with the extraction tool. connector damage is possible.**

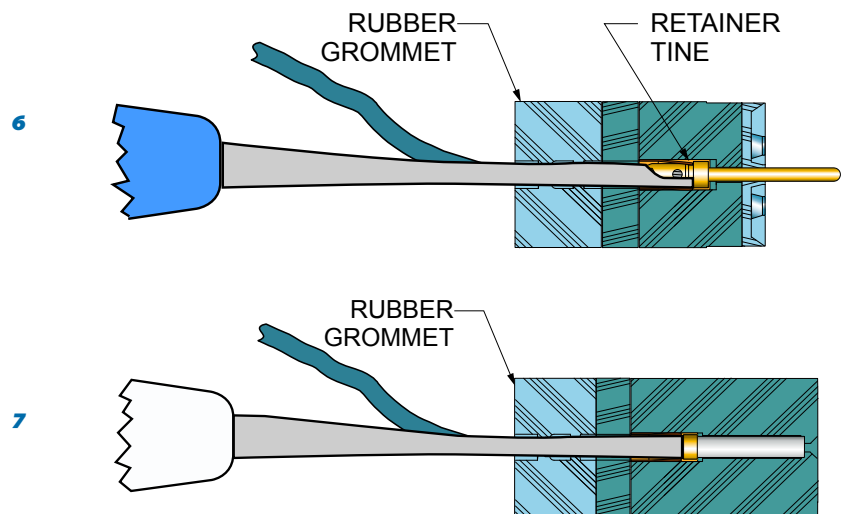

Dimensions in inches (millimeters) and are subject to change without notice.

Adapter for Crimping #20 AWG Wire to Size #23 Series 80 Contacts

Size #22 AWG wire is the largest wire size that fits the standard "Mighty Mouse" size 23 contacts. Use this adapter to attach larger #20 gage wire. First, crimp wire to adapter, then crimp the adapter into the size #23 contact. Adapters are made of tellurium copper alloy #1452, and are gold plated. Crimp with M22520/1-01 tool and 809-138 (Daniels TH653) positioner. *These adapters cannot be removed from connectors.*

Adapter Size	Wire Size	Part Number	Tool Code
#22-20	#20	809-093	C

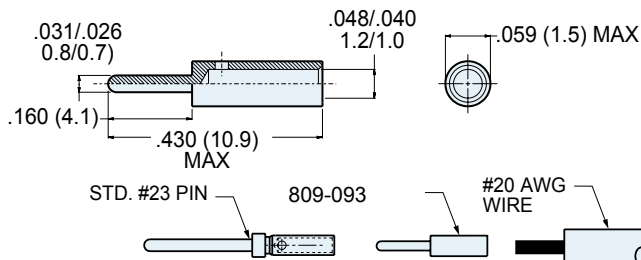

Size #16 Power Contacts, Crimp Termination

Standard size #16 contacts accept #16 to #20 AWG wire. At rated test current of 13 amps, the maximum voltage drop is 74 millivolts. Contacts are gold-plated copper alloy. Socket contacts feature stainless steel hoods to protect against probe damage. Approved to SAE-AMS-39029. Contacts are bulk packaged. Terminate with M22520/1-01 crimper and M22520/1-04 positioner.

Contact Type	Wire Size	Part Number	Military Part Number	Color Band			Tool Code
				1st	2nd	3rd	
Pin	#16 - #20	809-110	M39029/58-364	Orange	Blue	Yellow	D
Socket	#16 - #20	809-111	M39029/57-358	Orange	Green	Gray	D

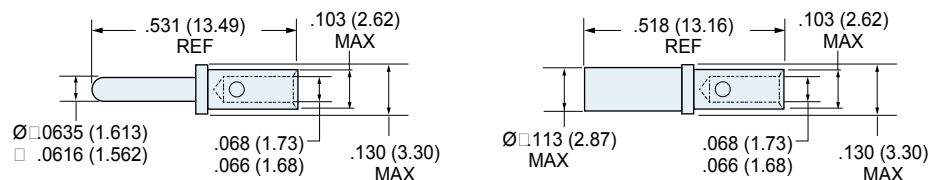
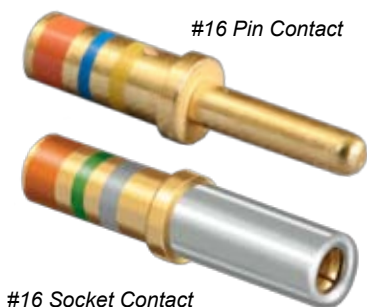

Size #12 Power Contacts, Crimp Termination

Standard size #12 contacts accept #12 to #14 AWG wire. At rated test current of 23 amps, the maximum voltage drop is 63 millivolts. Contacts are gold-plated copper alloy. Socket contacts feature stainless steel hoods to protect against probe damage. Approved to SAE AS39029. Contacts are bulk packaged. Terminate with M22520/1-01 crimper and M22520/1-04 positioner.

Contact Type	Wire Size	Part Number	Military Part Number	Color Band			Tool Code
				1st	2nd	3rd	
Pin	#12 - #14	809-112	M39029/58-365	Orange	Blue	Green	D
Socket	#12 - #14	809-113	M39029/57-359	Orange	Green	White	D

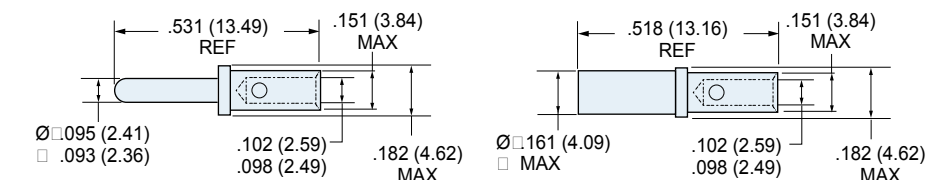

Dimensions in inches (millimeters) and are subject to change without notice.

Series 79 Micro-Crimp Micro-D for Mixed Signal, Power and Coaxial Applications



Size #16 Coaxial Contacts, Crimp Termination

These #16 contacts accept 50 ohm and 75 ohm coaxial cable. Inner contact is rated at 1 amp, the outer contact 12 amps. DWV voltage rating is 800 Vac rms sea level, 250 Vac at 50,000 feet. Contacts are packaged individually and are unassembled with instruction sheet. One contact consists of outer contact, fluorocarbon dielectric, inner contact and shield crimp sleeve. Inner and outer contacts are gold-plated copper alloy. Approved to SAE AS39029. VSWR rating 1.5:1 maximum up to 700 MHz. 5000 megohm insulation resistance.

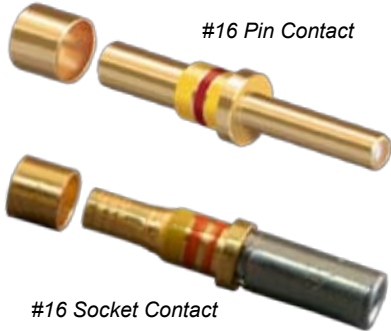

Type	Cable Size	Part Number	Military Part Number	Color Band			Tool Code
				1st	2nd	3rd	
Pin	RG174, RG316, RG179	809-114	M39029/76-424	Yellow	Red	Yellow	E
Pin	RG178	809-115	M39029/76-425	Yellow	Red	Green	E
Socket	RG174, RG316, RG179	809-116	M39029/78-432	Yellow	Orange	Red	E
Socket	RG178	809-117	M39029/78-433	Yellow	Orange	Orange	E

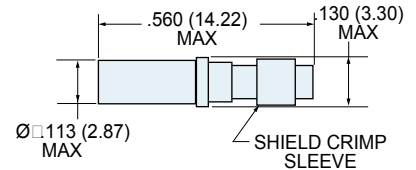
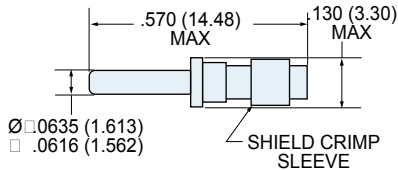

Size #12 Coaxial Contacts, Crimp Termination

These #12 contacts accept 50 ohm and 75 ohm coaxial cable. Inner contact is rated at 1 amp, the outer contact 12 amps. DWV voltage rating is 1000 Vac rms sea level, 250 Vac at 50,000 feet. Contacts are packaged individually and shipped unassembled with instruction sheet. One contact consists of outer contact, fluorocarbon dielectric, inner contact and shield crimp sleeve. Inner and outer contacts are gold-plated copper alloy. Approved to SAE AS39029. VSWR rating 1.5:1 maximum up to 700 MHz. 5000 megohm insulation resistance.

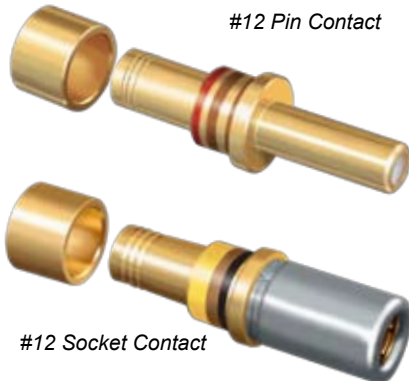

Type	Cable Size	Part Number	Military Part Number	Color Band			Tool Code
				1st	2nd	3rd	
Pin	RG174, RG316, RG179	809-118	M39029/28-211	Red	Brown	Brown	F
Pin	RG180	809-119	M39029/28-409	Yellow	Black	White	F
Socket	RG174, RG316, RG179	809-120	M39029/27-210	Red	Brown	Black	F
Socket	RG180	809-121	M39029/27-402	Yellow	Black	Red	F

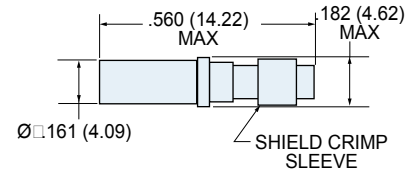
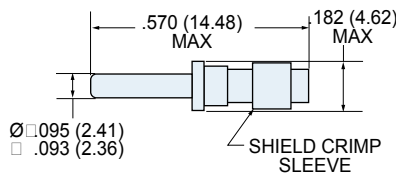

Size #12 50 Ohm High Frequency Coaxial Contacts, Crimp Termination

These contacts offer improved frequency response compared to standard coaxial contacts above. VSWR is 1.32:1 at 3GHz. Insertion loss at 3GHz is 20 dB maximum. Inner contact is rated at 1 amp, the outer contact 12 amps. DWV voltage rating is 1000 Vac rms sea level, 250 Vac at 50,000 feet. Contacts are packaged individually and shipped unassembled with instruction sheet. One contact consists of outer contact, fluorocarbon dielectric, inner contact and shield crimp sleeve. Inner and outer contacts are gold-plated copper alloy. 5000 megohm insulation resistance.

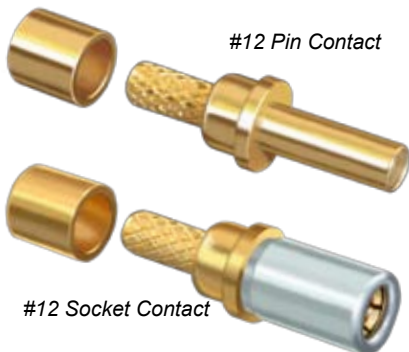

Contact Type	Cable Size	Part Number	Tool Code
Pin	RG178	809-123	G
Socket	RG178	809-122	G

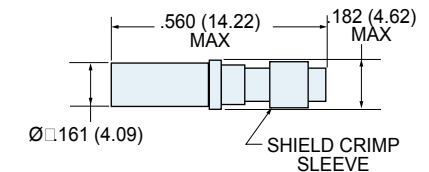
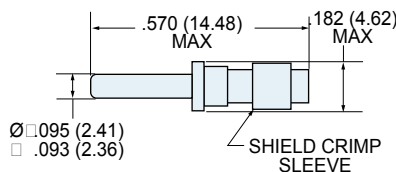

Dimensions in inches (millimeters) and are subject to change without notice.

Miniature Adjustable Crimp Tools



These crimp tools perform precision eight indent crimps for gas-tight wire terminations and excellent tensile strength. Adjustment wheel has 8 settings. Ratchet mechanism prevents improper crimps. Use with bayonet-type positioners. Check calibration with M22520/3 gages. Length is 6.75 inches, weight is approx. 10 oz.

1 Standard M22520/2-01 crimper. Use with standard size #23 "Mighty Mouse" contacts and with M39029/76 and /78 coaxial center contacts. Requires positioner, ordered separately.

2 Special MH992 crimper used with 50 ohm matched impedance coaxial inner contacts. Requires positioner 809-124 (K1360).

Figure	Part Number	Military Part Number	Daniels Part Number	Tool Code
1	809-015	M22520/2-01	AFM8	A, B, E
2	809-128	(none)	MH992	G

Positioners For Use With Miniature Adjustable Crimp Tools



These bayonet-type positioners hold contacts at correct height for crimping with M22520/2 type miniature step adjustable tools, above. Face plate shows correct tool settings.

3 Positioner for standard size #23 contacts. #22-#28 AWG. Use with 809-015 crimp tool.

6 Positioner for matched impedance #12 coaxial inner contact. Use with 809-128 crimp tool.

4 Positioner for small bore size #23 contacts. #26-#30 AWG. Use with 809-015 crimp tool.

7 Positioner for M39029/27 and 28 #12 coaxial inner contact. Use with 809-015 crimp tool.

5 Positioner for M39029/76 and 78 coaxial inner contact. Use with 809-015 crimp tool.

Figure	Part Number	Military Part Number	Daniels Part Number	Tool Code
3	809-005	(none)	K1461	A
4	809-057	(none)	(none)	B
5	809-125	M22520/2-35	K532-1	E
6	809-124	None	K1360	G
7	809-135	M22520/2-34	K323	F

Crimp Tool And Positioner For #12 and #16 Power Contacts and 809-093 Adapters



1 Crimp tool for use with size #16 and #12 power pins. 9.75 inches OAL, 1.25 pounds. Use with M39029/57 and /58 contacts and 809-093 adapters.

2 Positioner for use with size #12 and #16 Power contacts.

3 Positioner for use with 809-093 adapters.

Figure	Part Number	Military Part Number	Daniels Part Number	Tool Code
1	809-136	M22520/1-01	AF8	C, D
2	809-137	M22520/1-02	TH163	D
3	809-138	(none)	TH653	C

Dimensions in inches (millimeters) and are subject to change without notice.

CAGE Code 06324

Printed in U.S.A.

Crimp Tool And Positioner For #16 Coaxial Outer Contact



For crimping size #16 shield sleeves. These mil spec approved tools feature a ratchet mechanism to prevent damage from overcrimping. Check calibration with M22520/3 gage.

- 1** Crimp tool for use with size #16 coaxial contacts. Blue handles. 9.75 inches OAL, 1.25 pounds.
- 2** Positioner for use with size #16 coaxial contacts. Use with 809-127 (M22520/4-01) crimp tool.

Figure	Part Number	Military Part Number	Daniels Part Number	Tool Code
1	809-127	M22520/4-01	GS100-1	E
2	809-126	M22520/4-02	GP295	E

Crimp Tool And Positioner For #12 Coaxial Outer Contact



For crimping size #12 shield sleeves. These mil spec approved tools feature a ratchet mechanism to prevent damage from overcrimping. Check calibration with M22520/3 gage.

- 1** Crimp tool for use with size #12 coaxial contacts. Black handles. 9.75 inches OAL, 1.25 pounds.
- 2** Positioner for use with size #12 coaxial contacts. Use with 809-133 (M22520/31-01) crimp tool.

Figure	Part Number	Military Part Number	Daniels Part Number	Tool Code
1	809-133	M22520/31-01	GS200-1	F
2	809-134	M22520/31-02	G2P330	F

Parallel Action Crimp Tool and Hex Die Set for 50 Ohm Matched Impedance #12 Coax



- 1** Parallel action tool for use with hex crimp dies. 11 inches OAL, 2.0 pounds. Anodized aluminum frame, steel mechanism, plastic handles. Includes tool for die set removal. Accepts all M22520/5 die sets.

- 2** Die set for terminating coaxial shield to outer contact. Use with size #12 matched impedance M39029/102 and 103 type coaxial contacts. Set consists of upper and lower halves. Made of hardened steel with black oxide finish. Approximately 2 inches in length, assembled. Die set has two closures per illustration.

Figure	Part Number	Military Part Number	Daniels Part Number	Tool Code
1	809-129	M22520/5-01	HX4	G
2	809-130	M22520/5-03	Y196	G

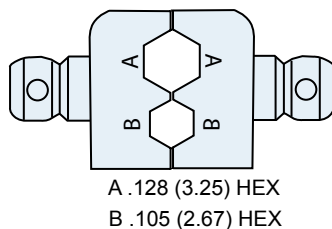

Dimensions in inches (millimeters) and are subject to change without notice.

Contact Insertion and Removal Tools



1 Insertion/Extraction Tool for #23 Contacts. For use with all Series 80 connectors with size #23 contacts, this economical tool features molded plastic grips and sturdy stainless steel tips.

2 Insertion Tool for #23 Contacts. For use with all Series 80 connectors with size #23 contacts, this tool features anodized aluminum handle and stainless steel insertion tip.

3 Insertion/Extraction Tool for #16 Contacts. Use with size #16 coaxial or power contacts. Economical molded plastic. White extraction tip, blue insertion tip.

4 Insertion/Extraction Tool for #12 Contacts. Use with size #12 coaxial or power contacts. Economical molded plastic. White extraction tip, yellow insertion tip.

Figure	Size	Type	Part Number	Military Part Number	Daniels Part Number
1	#23	Insertion/Extraction	809-088	(None)	(None)
2	#23	Insertion Only	809-013	(None)	DAK225-22
3	#16	Insertion/Extraction	809-131	M81969/14-03	(None)
4	#12	Insertion/extraction	809-132	M81969/14-04	(None)

Contact Retention Tester



Check for properly seated contacts with this spring-loaded tester. Apply the tool tip to the mating end of a contact. Push on the handle until the spring compresses to the recommended force. A visual indicator shows full compression. The contact is properly retained if it is not displaced.

The adjustable handle should be set to 3.2 pounds (14.2 N). The pin tip is used with #23 pin contacts. The socket tip is used with #23 socket contacts.

Order the complete kit, or order the tips and handle separately.

Figure	Description	Part Number	Daniels Part Number
1	Handle	809-107-1	HT250-2
2	Pin Tip	809-107-2	68-023-01
	Socket Tip (not shown)	809-107-3	67-023-01
	Complete Kit	809-107-4	(None)

Dimensions in inches (millimeters) and are subject to change without notice.

CAGE Code 06324

Printed in U.S.A.

BAND-IT® Shield Termination System

Fast, cost-effective shield termination. Attach cable shields to Series 80 connectors or backshells with **BAND-IT®** stainless steel straps. The **BAND-IT®** system offers fast termination and the flexibility to handle a wide range of parts with just one band size. Approved for aerospace and defense, these straps have successfully passed rigorous shock, vibration and environmental testing.



1 Micro Band Installation Tool. Use with .120" (3.05 mm) wide bands. 6.75 inches (172 mm.) length, 1.2 pounds (0.6 Kg.)

2 Micro Band, .120" (3.05 mm) wide. Available in two lengths, flat or pre-coiled. Stainless steel.

Figure	Description	Part Number
1	Micro Band Installation Tool	600-061

Figure	Length		Part Number		Accommodates Diameter	
	in.	mm.	Flat	Pre-Coiled	in.	mm.
2	8.125	206.38	600-057	600-057-1	.88	22.35
2	14.250	361.95	600-083	600-083-1	1.88	47.75

Contact Glenair or visit our website (glenair.com) to view our complete line of **BAND-IT®** products, including pneumatic tools for high volume production and calibration kits.

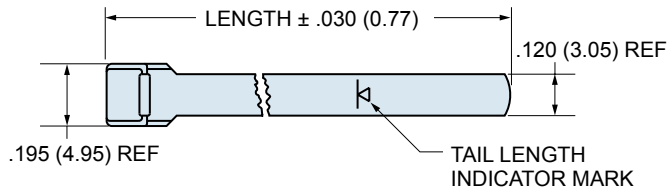

BAND-IT® Shield Termination Instructions

1. Prepare Cable Braid for termination process (Figure 1).
2. Push Braid forward over Adapter Retention Lip to the Adapter Incline Point (or .4" [10.2mm] minimum braid length). Milk Braid as required to remove slack and insure a snug fit around the shield termination area (Figure 2).
3. Prepare the Band in the following manner:
 - A. Roll Band through the Buckle Slot twice. (Bands must be double-coiled.)
 - B. Pull on Band until Mark (▶) is within approximately .250 inch (6.4mm) of Buckle Slot (Figure 3). The Band may be tightened further if desired.

NOTE: Prepared Band should have (▶) Mark visible approximately where shown in Figure 3.

Shield Termination Clamping Process (Figures 4 thru 8)

NOTE: To free Tool Handles, move Holding Clips to center of Tool.

4. Squeeze Gripper Release Lever and insert Band into the front end opening of the Tool. (NOTE: Circular portion of looped band must always face downward.)
5. Aligning the Band and Tool with the Shield Termination Area, squeeze Black Pull-Up Handle repeatedly using short strokes until it locks against Tool Body. (This indicates the Band is compressed to the Tool Pre-calibrated Tension.)
6. Complete the Clamping Process by squeezing the Gray Cut-Off Handle.
7. Remove excess band from tool and dispose.
8. Inspect Shield Termination.

NOTE: If alignment of band and shield is unsatisfactory, tension on band can be relaxed by pushing on slotted release lever on top of tool. Make adjustments as necessary and again squeeze black pull-up handle.

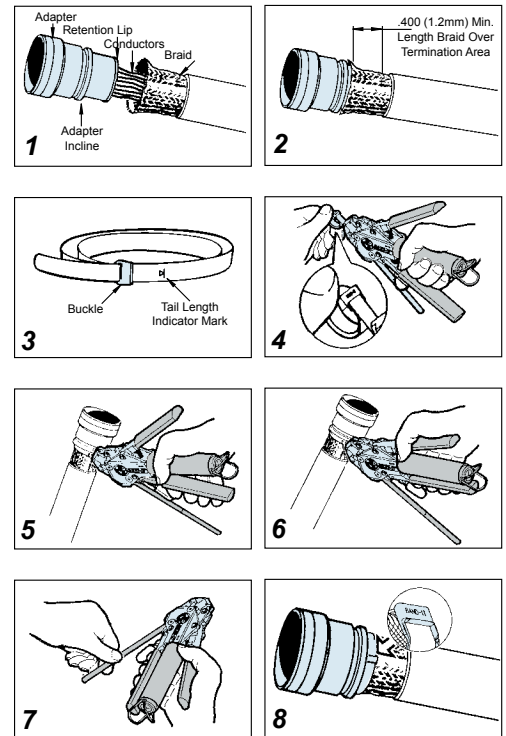

Dimensions in inches (millimeters) and are subject to change without notice.

Cable Receptacles With Male Pins, Crimp Termination, 790-024



Connectors feature machined aluminum housings, beryllium copper contact retention clips and fluorosilicone rubber seals. Connectors are supplied with loose contacts for crimping to wire. Choose RoHS-compliant electroless nickel for best EMI performance. Contacts snap in place and are removable. Contacts are plated with 50 millionths thick gold over nickel underplate. Signal contacts are size #23 and accept #22 through #28 AWG copper wire.

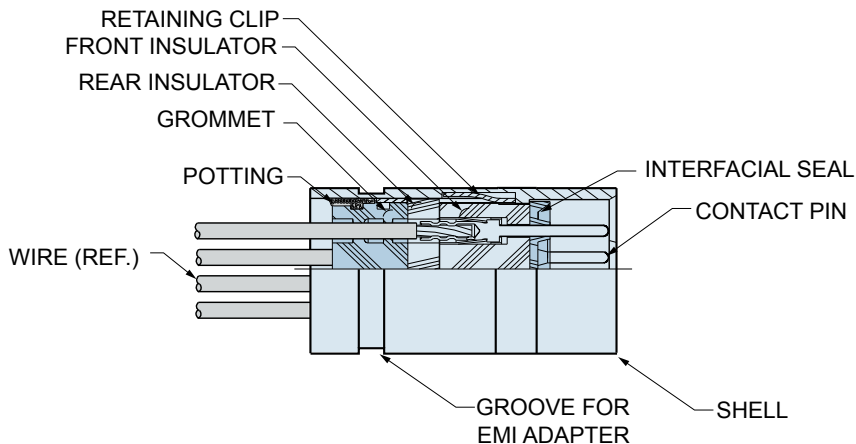

MOUNTING HARDWARE



N
Thru-Hole

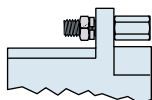

P
Jackpost

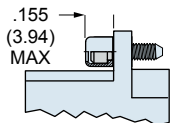

L
Jackscrew, Hex Head, Low-Profile

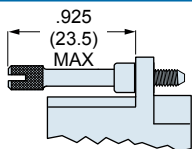

K
Jackscrew, Slot Head, Extended

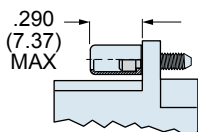

S
Screwlock, Hex Head, Low-Profile

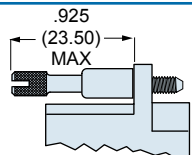

T
Screwlock, Slot Head, Extended

Thread size is #2-56 for shell sizes A,B,C,D,E,F,G,J, and K. Thread size is #4-40 for shell sizes H and L.

Screwlocks allow full mating of the connectors before the screws are fastened. Jackscrews must be tightened to mate the connectors.

How To Order

Cable Receptacle, Pin Contacts

Shell Plating

M - Electroless Nickel
NF - Cadmium, Olive Drab
UC - Zinc-Cobalt, Black
J - Cadmium, Yellow Chromate
Z2 - Gold
E - Chem Film

790-024P

C-13

M

P

Insert Arrangement
(See Page 6)

Hardware Option

N - No Hardware Supplied
P - Jackposts
L - Jackscrew, Hex Head, Low-Profile
K - Jackscrew, Slot Head, Extended
S - Screw Lock, Hex Head, Low-Profile
T - Screw Lock, Slot Head, Extended

Dimensions in inches (millimeters) and are subject to change without notice.

Series 79 Micro-Crimp Micro-D for Mixed Signal, Power and Coaxial Applications



790-024P DIMENSIONS

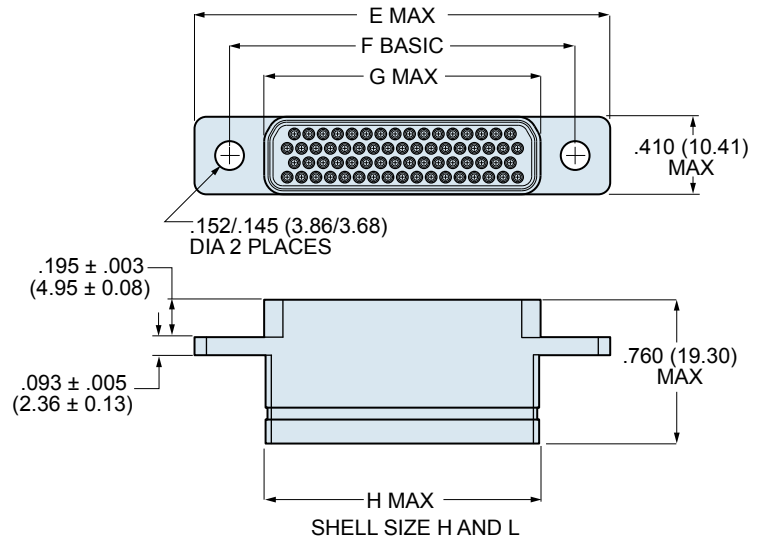
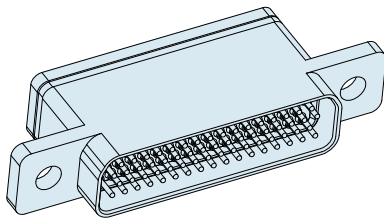
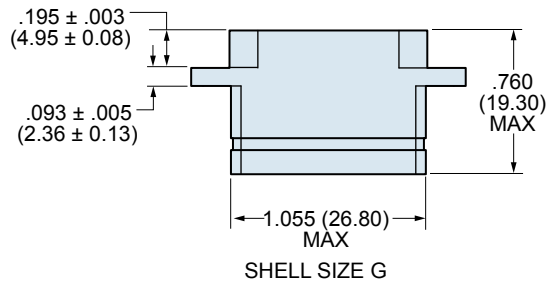
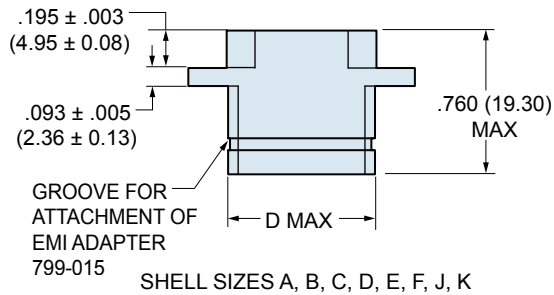
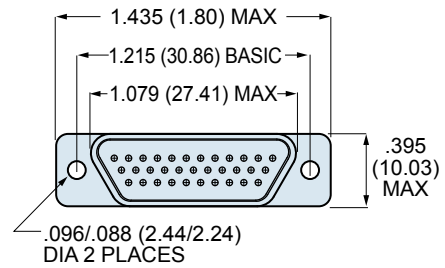
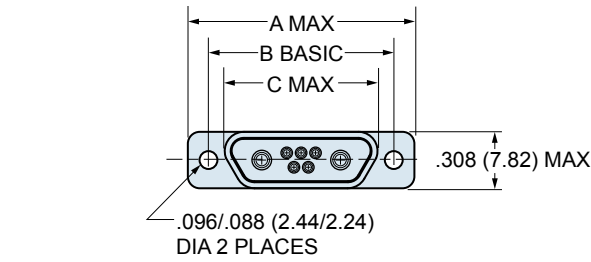

Shell Size	A Max.		B Basic		C Max.		D Max.		E Max.		F Basic		G Max.		H Max.	
	In.	mm.	In.	mm.	In.	mm.	In.	mm.	In.	mm.	In.	mm.	In.	mm.	In.	mm.
A	.785	19.94	.565	14.35	.400	10.16	.390	9.91	—	—	—	—	—	—	—	—
B	.935	23.75	.715	18.16	.551	14.00	.540	13.72	—	—	—	—	—	—	—	—
C	1.085	27.65	.865	21.97	.701	17.81	.690	17.53	—	—	—	—	—	—	—	—
D	1.185	30.10	.965	24.51	.801	20.35	.790	20.07	—	—	—	—	—	—	—	—
E	1.335	33.91	1.115	28.32	.951	24.16	.940	23.88	—	—	—	—	—	—	—	—
F	1.485	37.72	1.265	32.13	1.101	27.96	1.090	27.69	—	—	—	—	—	—	—	—
H	—	—	—	—	—	—	—	—	2.175	55.25	1.800	45.72	1.450	36.83	1.440	36.58
J	1.845	46.86	1.615	41.02	1.460	37.08	1.450	36.83	—	—	—	—	—	—	—	—
K	2.240	56.90	2.015	51.18	1.860	47.24	1.840	46.74	—	—	—	—	—	—	—	—
L	—	—	—	—	—	—	—	—	2.420	61.47	2.036	51.71	1.686	42.82	1.675	42.55

Dimensions in inches (millimeters) and are subject to change without notice.

Cable Plugs with Female Socket Contacts, Crimp Termination, 790-025



Connectors feature machined aluminum housings, beryllium copper contact retention clips and fluorosilicone rubber seals. Connectors are supplied with loose contacts for crimping to wire. Choose RoHS-compliant electroless nickel for best EMI performance. Contacts snap in place and are removable. Contacts are plated with 50 millionths thick gold over nickel underplate. Signal contacts are size #23 and accept #22 through #28 AWG copper wire.

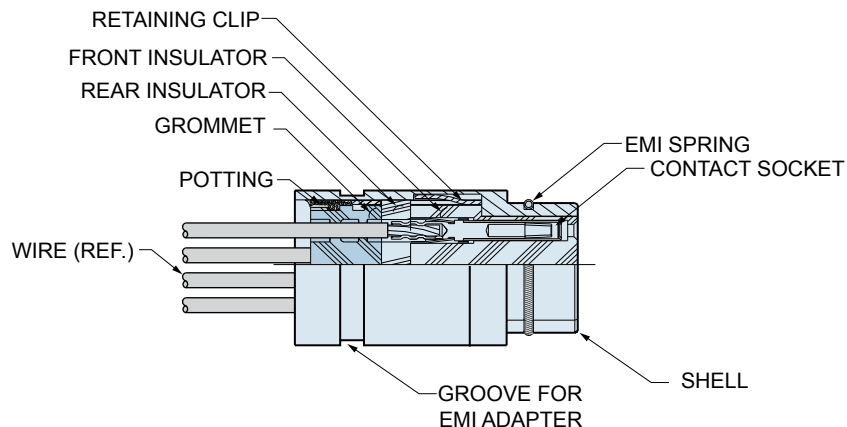

MOUNTING HARDWARE



N
Thru-Hole

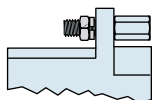

P
Jackpost

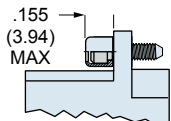

L
Jackscrew, Hex Head, Low-Profile

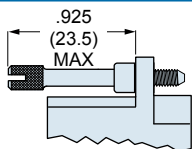

K
Jackscrew, Slot Head, Extended

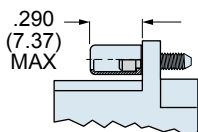

S
Screwlock, Hex Head, Low-Profile

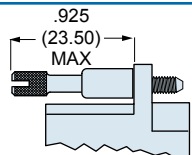

T
Screwlock, Slot Head, Extended

Thread size is #2-56 for shell sizes A,B,C,D,E,F,G,J, and K. Thread size is #4-40 for shell sizes H and L.

Screwlocks allow full mating of the connectors before the screws are fastened. Jackscrews must be tightened to mate the connectors.

How To Order

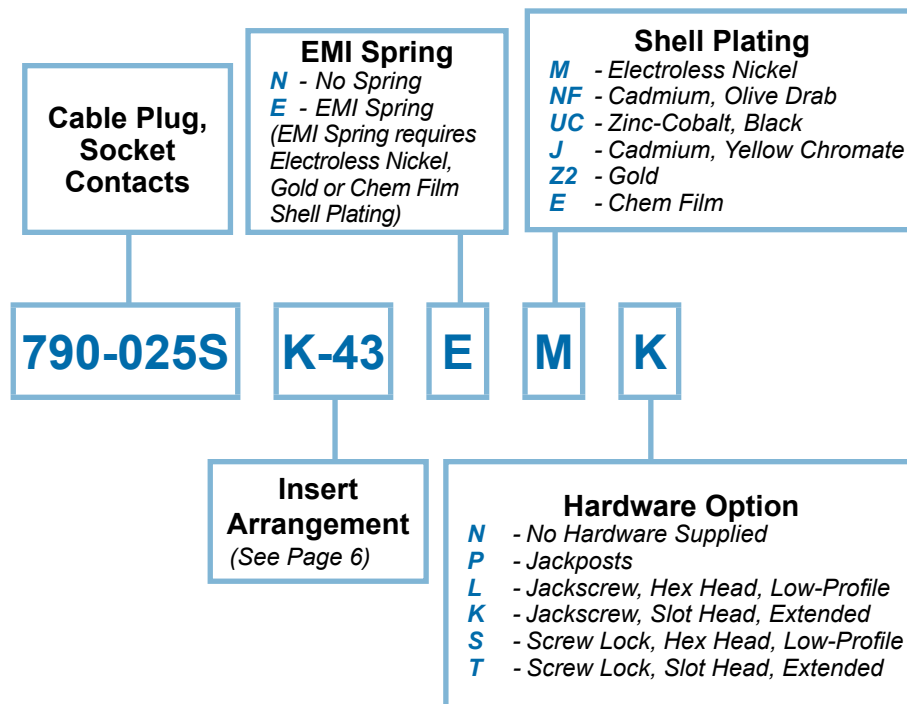

Dimensions in inches (millimeters) and are subject to change without notice.

Series 79 Micro-Crimp Micro-D for Mixed Signal, Power and Coaxial Applications



790-025S DIMENSIONS

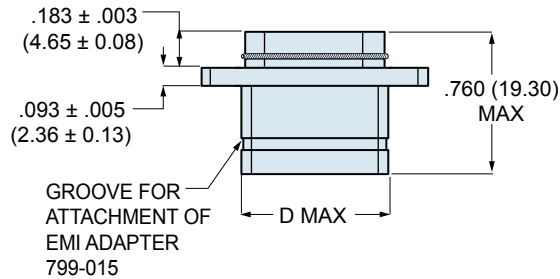
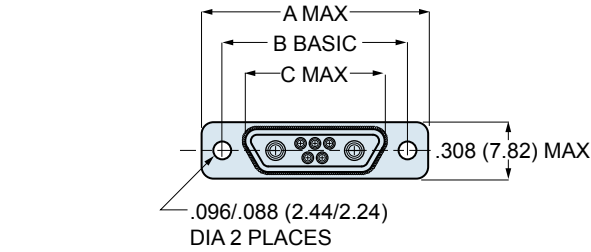

SHELL SIZES A, B, C, D, E, F, J, K

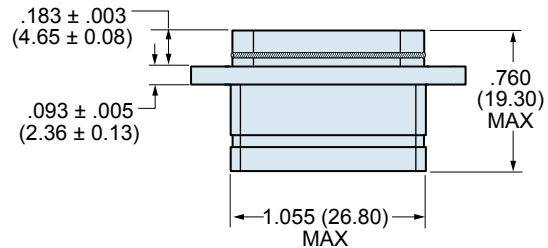
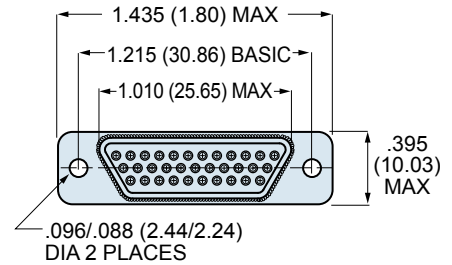
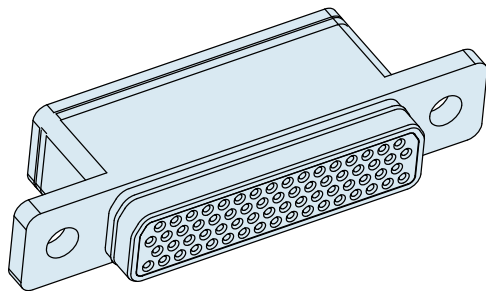

SHELL SIZE G

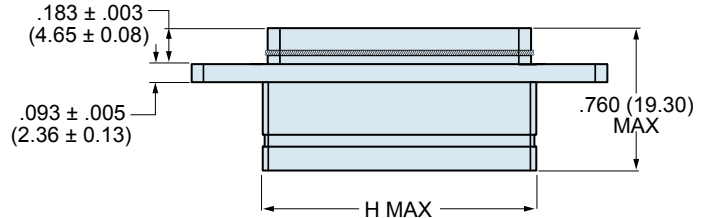
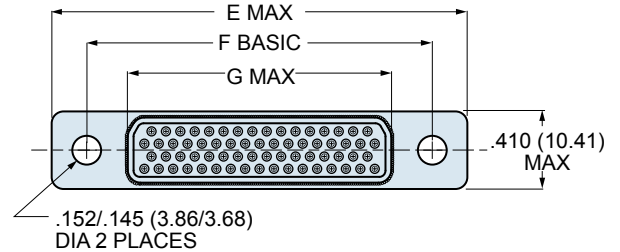

SHELL SIZE H AND L

Shell Size	A Max.		B Basic		C Max.		D Max.		E Max.		F Basic		G Max.		H Max.	
	In.	mm.	In.	mm.	In.	mm.	In.	mm.	In.	mm.	In.	mm.	In.	mm.	In.	mm.
A	.785	19.94	.565	14.35	.335	8.51	.390	9.91	—	—	—	—	—	—	—	—
B	.935	23.75	.715	18.16	.485	12.32	.540	13.72	—	—	—	—	—	—	—	—
C	1.085	27.65	.865	21.97	.635	16.13	.690	17.53	—	—	—	—	—	—	—	—
D	1.185	30.10	.965	24.51	.735	18.67	.790	20.07	—	—	—	—	—	—	—	—
E	1.335	33.91	1.115	28.32	.885	22.48	.940	23.88	—	—	—	—	—	—	—	—
F	1.485	37.72	1.265	32.13	1.035	26.29	1.090	27.69	—	—	—	—	—	—	—	—
H	—	—	—	—	—	—	—	—	2.175	55.25	1.800	45.72	1.385	35.18	1.440	36.58
J	1.845	46.86	1.615	41.02	1.390	35.61	1.450	36.83	—	—	—	—	—	—	—	—
K	2.240	56.90	2.015	51.18	1.795	45.59	1.840	46.74	—	—	—	—	—	—	—	—
L	—	—	—	—	—	—	—	—	2.420	61.47	2.036	51.71	1.623	41.22	1.675	42.55

Dimensions in inches (millimeters) and are subject to change without notice.

Panel Mount Receptacles, Pin Contacts, Crimp Termination, 790-026

Connectors feature machined aluminum housings, beryllium copper contact retention clips and fluorosilicone rubber seals. Silver-filled fluorosilicone panel gasket provides environmental seal to panel. Connectors are supplied with loose contacts for crimping to wire. Contacts snap in place and are removable. Contacts are plated with 50 millionths thick gold over nickel underplate. Signal contacts are size #23 and accept #22 through #28 AWG copper wire.

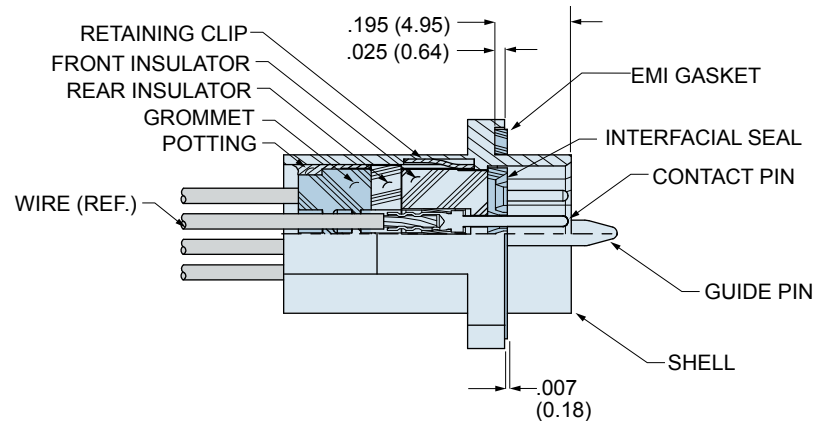

MATING HARDWARE

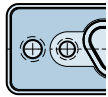

N
No Mating Hardware. See Note 1 Below.



P
Jackposts. See Note 2 Below.

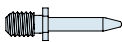

G
Male Guide Pins



S
Female Guide Sockets

1. N option: connector is supplied with blind, tapped holes. Shell sizes H and L have 6-32 UNC-2B thread, other sizes are #4-40. .150" minimum thread depth.
2. P option: connector is supplied with non-removable jackposts. Shell sizes H and L have #4-40 UNC-2B thread, other sizes have #2-56 thread.

How To Order

Panel Mount Receptacle, Pin Contacts, Crimp Termination

Shell Plating

M - Electroless Nickel
NF - Cadmium, Olive Drab
UC - Zinc-Cobalt, Black
J - Cadmium, Yellow Chromate
Z2 - Gold
E - Chem Film

790-026P

L-6P6

M

G

Insert Arrangement
(See Page 6)

Hardware Option
N - No Hardware Supplied
P - Jackposts
G - Guide Pins
S - Guide Sockets

Dimensions in inches (millimeters) and are subject to change without notice.

Series 79 Micro-Crimp Micro-D for Mixed Signal, Power and Coaxial Applications



790-026P SHELL SIZE A,B,C,D,E,F,J,K DIMENSIONS

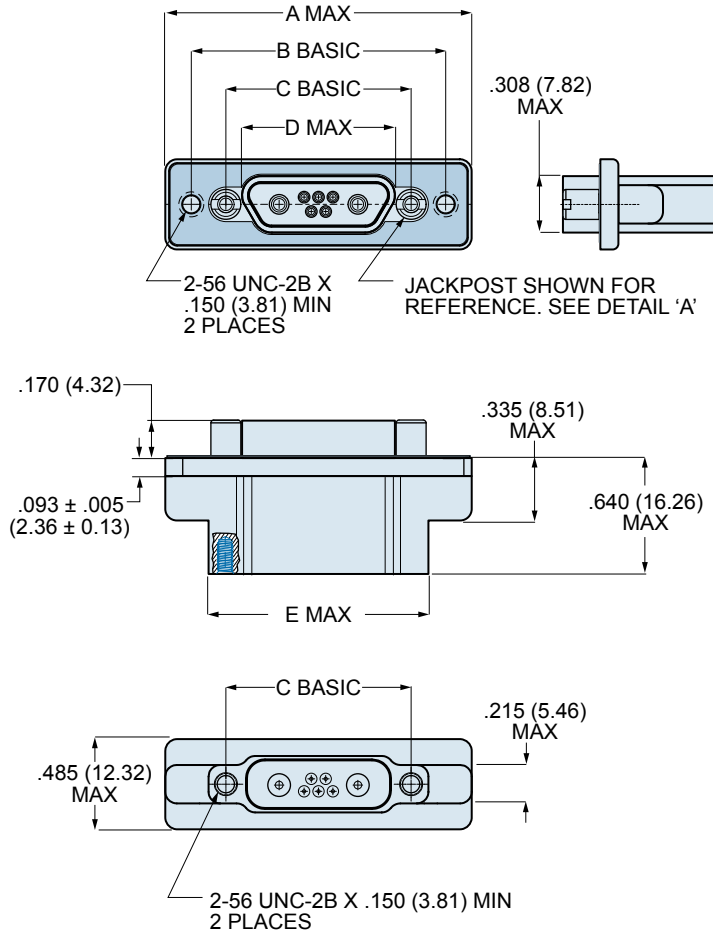

NOTES

1. REFER TO DRAWING 799-009 FOR INSERT ARRANGEMENTS.
2. REFER TO DRAWING 799-008 FOR MATERIALS, FINISHES, AND PERFORMANCE SPECIFICATIONS.
3. REFER TO DRAWING 799-010 FOR APPLICATION TOOLING INFORMATION.
4. REFER TO DRAWING 799-005 FOR PANEL CUTOUTS.

BLIND MATE

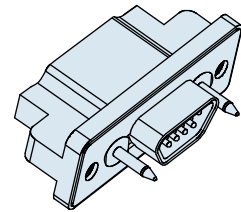

SHELL SIZES A, B, C, D, E, F, G, J, K
+/- .030 (0.76) ALLOWABLE
MISALIGNMENT FROM CENTERLINE

Shell Size	A Max.		B Basic		C Basic		D Max.		E Max.	
	In.	mm.	In.	mm.	In.	mm.	In.	mm.	In.	mm.
A	1.211	30.76	.925	23.50	.565	14.35	.401	10.19	.760	19.30
B	1.361	34.57	1.075	27.31	.715	18.16	.551	14.00	.910	21.11
C	1.511	38.38	1.225	31.12	.865	21.97	.701	17.81	1.060	26.92
D	1.611	40.92	1.325	33.66	.965	24.51	.801	20.35	1.160	29.46
E	1.761	44.73	1.475	37.47	1.115	28.32	.951	24.16	1.310	33.27
F	1.911	48.54	1.625	41.28	1.265	32.13	1.101	27.96	1.460	37.08
J	2.261	57.43	1.975	50.17	1.615	41.02	1.456	36.98	1.810	45.97
K	2.661	67.59	2.375	60.33	2.015	51.18	1.860	47.24	2.210	56.13

Dimensions in inches (millimeters) and are subject to change without notice.

790-026P SHELL SIZE G DIMENSIONS

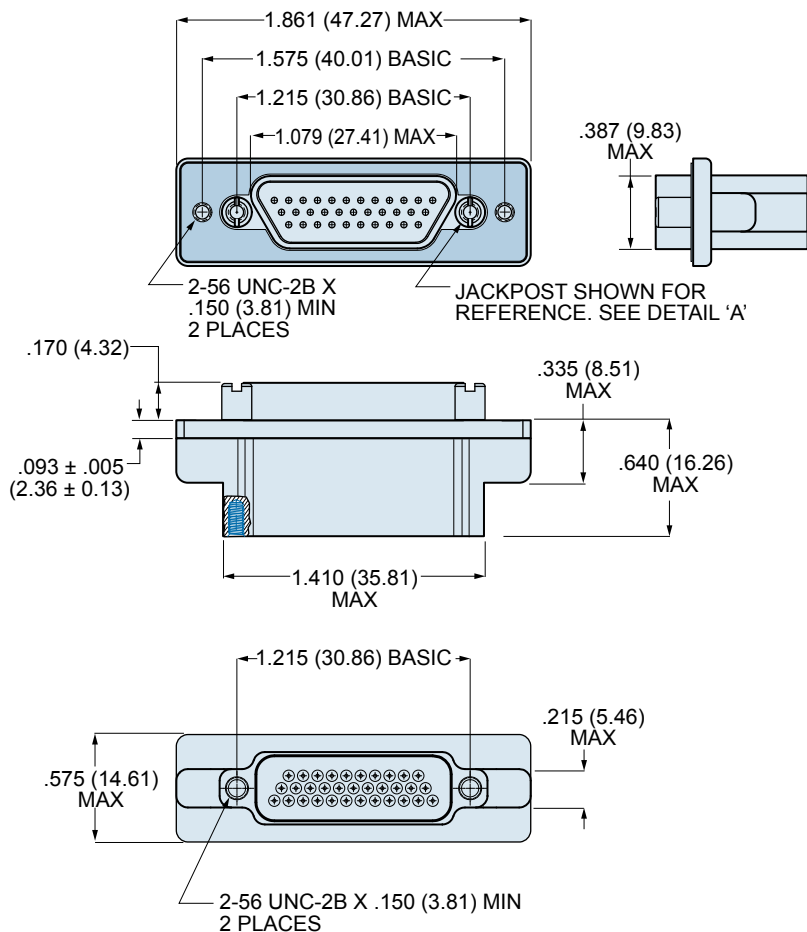

NOTES

1. REFER TO DRAWING 799-009 FOR INSERT ARRANGEMENTS.
2. REFER TO DRAWING 799-008 FOR MATERIALS, FINISHES, AND PERFORMANCE SPECIFICATIONS.
3. REFER TO DRAWING 799-010 FOR APPLICATION TOOLING INFORMATION.
4. REFER TO DRAWING 799-005 FOR PANEL CUTOUTS.

BLIND MATE

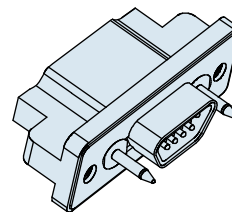

SHELL SIZES A, B, C, D, E, F, G, J, K
+/- .030 (0.76) ALLOWABLE
MISALIGNMENT FROM CENTERLINE

Dimensions in inches (millimeters) and are subject to change without notice.

Series 79 Micro-Crimp Micro-D for Mixed Signal, Power and Coaxial Applications



790-026P SHELL SIZE H AND L DIMENSIONS

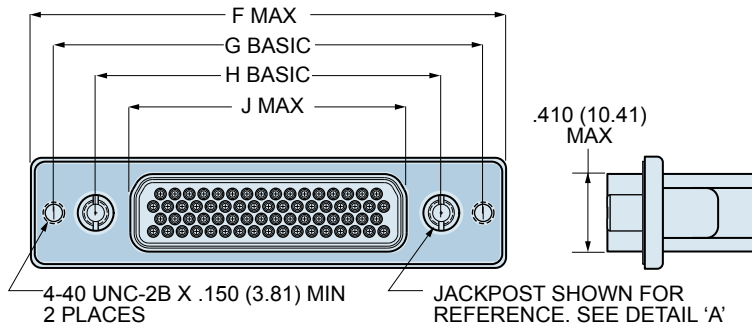

NOTES

1. REFER TO DRAWING 799-009 FOR INSERT ARRANGEMENTS.
2. REFER TO DRAWING 799-008 FOR MATERIALS, FINISHES, AND PERFORMANCE SPECIFICATIONS.
3. REFER TO DRAWING 799-010 FOR APPLICATION TOOLING INFORMATION.
4. REFER TO DRAWING 799-005 FOR PANEL CUTOUTS.

BLIND MATE

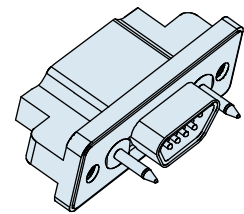

SHELL SIZES H, L
+/- .040 (1.02) ALLOWABLE MISALIGNMENT
FROM CENTERLINE

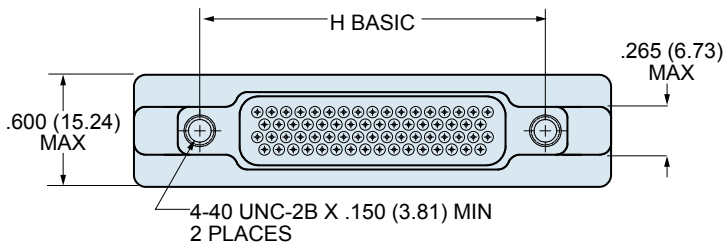
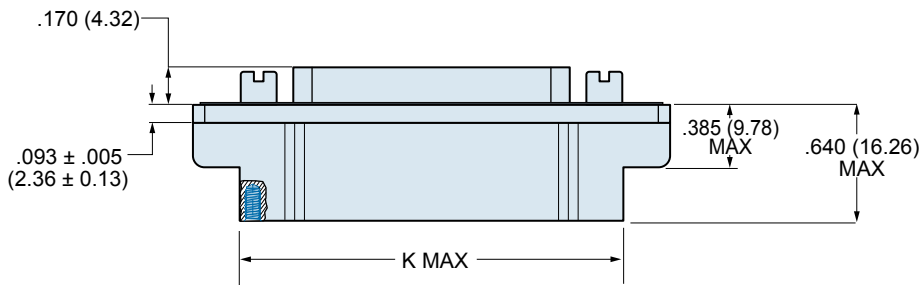

Shell Size	F Max.		G Basic		H Basic		J Max.		K Max.	
	In.	mm.	In.	mm.	In.	mm.	In.	mm.	In.	mm.
H	2.500	63.50	2.236	56.79	1.800	45.72	1.450	36.83	2.045	51.94
L	2.736	69.49	2.472	62.79	2.036	51.71	1.686	42.82	2.281	57.94

Dimensions in inches (millimeters) and are subject to change without notice.

Panel Mount Plugs, Socket Contacts, Crimp Termination, 790-027

Connectors feature machined aluminum housings, beryllium copper contact retention clips and fluorosilicone rubber seals. Silver-filled fluorosilicone panel gasket provides environmental seal to panel. Connectors are supplied with loose contacts for crimping to wire. Contacts snap in place and are removable. Contacts are plated with 50 millionths thick gold over nickel underplate. Signal contacts are size #23 and accept #22 through #28 AWG copper wire.

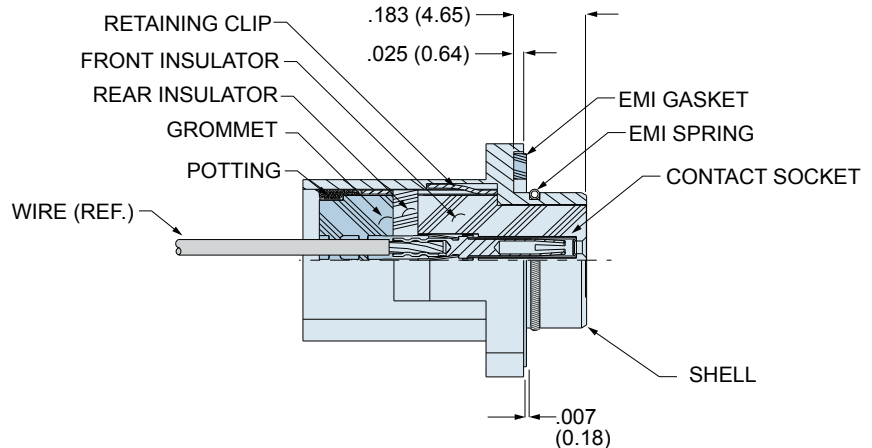

MATING HARDWARE

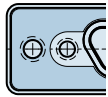

N
No Mating Hardware. See Note 1 Below.



P
Jackposts. See Note 2 Below.

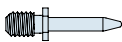

G
Male Guide Pins



S
Female Guide Sockets

1. N option: connector is supplied with blind, tapped holes. Shell sizes H and L have 6-32 UNC-2B thread, other sizes are #4-40. .150" minimum thread depth.
2. P option: connector is supplied with non-removable jackposts. Shell sizes H and L have #4-40 UNC-2B thread, other sizes have #2-56 thread.

How To Order

Panel Mount Plug, Socket Contacts, Crimp Termination

Shell Plating

M - Electroless Nickel
NF - Cadmium, Olive Drab
UC - Zinc-Cobalt, Black
J - Cadmium, Yel Chromate
ZZ - Gold
E - Chem Film

EMI Spring

N - No Spring
E - EMI Spring
(EMI Spring requires Electroless Nickel, Gold or Chem Film Shell Plating)

790-027S

H-36W2

M

E

N

Insert Arrangement
(See Page 6)

Hardware Option

N - No Hardware Supplied
P - Jackposts
G - Guide Pins
S - Guide Sockets

Dimensions in inches (millimeters) and are subject to change without notice.

Series 79 Micro-Crimp Micro-D for Mixed Signal, Power and Coaxial Applications



790-027S SHELL SIZE A,B,C,D,E,F,J,K DIMENSIONS

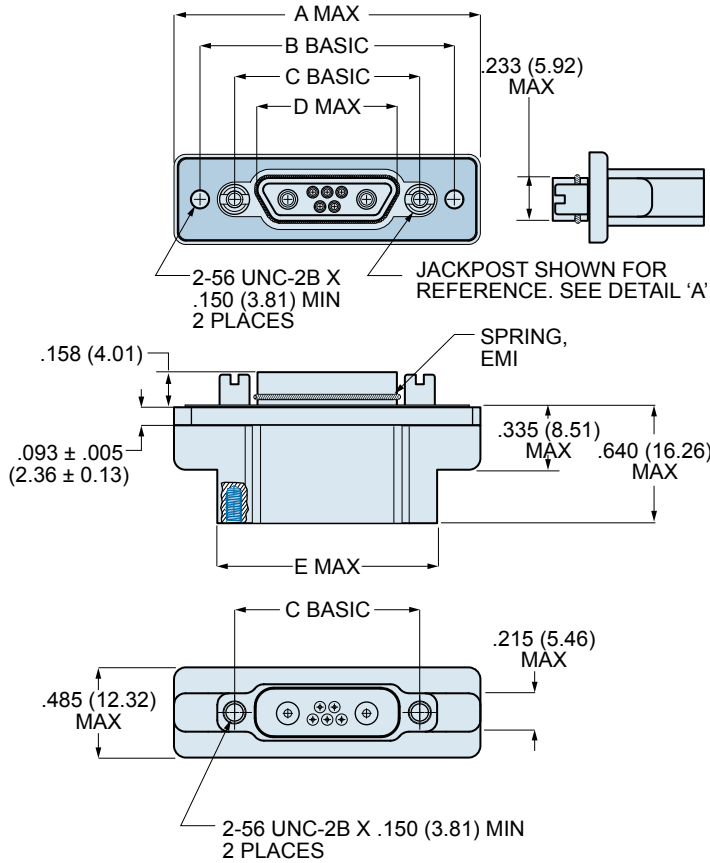

NOTES

1. REFER TO DRAWING 799-009 FOR INSERT ARRANGEMENTS.
2. REFER TO DRAWING 799-008 FOR MATERIALS, FINISHES, AND PERFORMANCE SPECIFICATIONS.
3. REFER TO DRAWING 799-010 FOR APPLICATION TOOLING INFORMATION.
4. REFER TO DRAWING 799-005 FOR PANEL CUTOUTS.

BLIND MATE

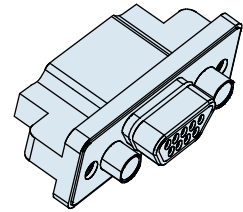

SHELL SIZES A, B, C, D, E, F, G, J, K
+/- .030 (0.76) ALLOWABLE
MISALIGNMENT FROM CENTERLINE

Shell Size	A Max.		B Basic		C Basic		D Max.		E Max.	
	In.	mm.	In.	mm.	In.	mm.	In.	mm.	In.	mm.
A	1.211	30.76	.925	23.50	.565	14.35	.335	8.51	.760	19.30
B	1.361	34.57	1.075	27.31	.715	18.16	.485	12.32	.910	21.11
C	1.511	38.38	1.225	31.12	.865	21.97	.635	16.13	1.060	26.92
D	1.611	40.92	1.325	33.66	.965	24.51	.735	18.67	1.160	29.46
E	1.761	44.73	1.475	37.47	1.115	28.32	.885	22.48	1.310	33.27
F	1.911	48.54	1.625	41.28	1.265	32.13	1.035	26.29	1.460	37.08
J	2.261	57.43	1.975	50.17	1.615	41.02	1.390	35.31	1.810	45.97
K	2.661	67.59	2.375	60.33	2.015	51.18	1.795	45.59	2.210	56.13

Dimensions in inches (millimeters) and are subject to change without notice.

790-027S SHELL SIZE G DIMENSIONS

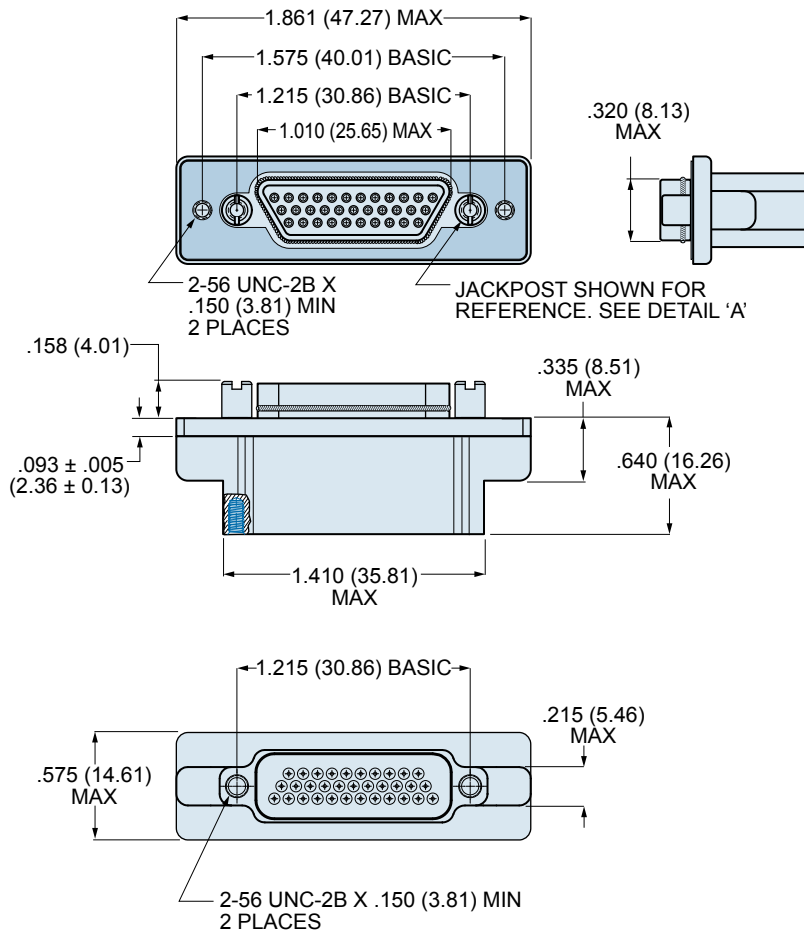

NOTES

1. REFER TO DRAWING 799-009 FOR INSERT ARRANGEMENTS.
2. REFER TO DRAWING 799-008 FOR MATERIALS, FINISHES, AND PERFORMANCE SPECIFICATIONS.
3. REFER TO DRAWING 799-010 FOR APPLICATION TOOLING INFORMATION.
4. REFER TO DRAWING 799-005 FOR PANEL CUTOUTS.

BLIND MATE

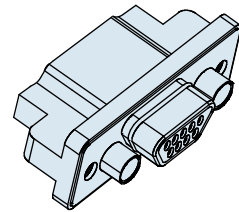

SHELL SIZES A, B, C, D, E, F, G, J, K
+/- .030 (0.76) ALLOWABLE
MISALIGNMENT FROM CENTERLINE

Dimensions in inches (millimeters) and are subject to change without notice.

Series 79 Micro-Crimp Micro-D for Mixed Signal, Power and Coaxial Applications



790-027S SHELL SIZE H AND L DIMENSIONS

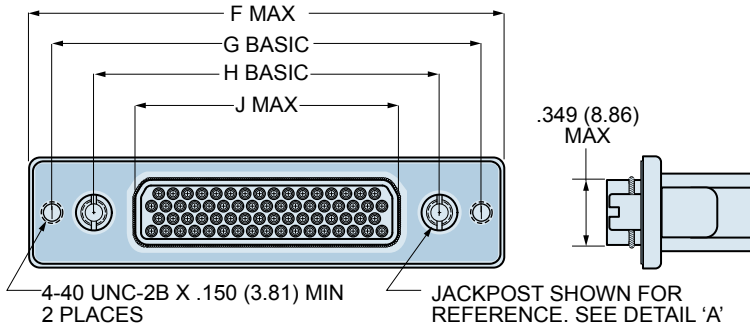

NOTES

1. REFER TO DRAWING 799-009 FOR INSERT ARRANGEMENTS.
2. REFER TO DRAWING 799-008 FOR MATERIALS, FINISHES, AND PERFORMANCE SPECIFICATIONS.
3. REFER TO DRAWING 799-010 FOR APPLICATION TOOLING INFORMATION.
4. REFER TO DRAWING 799-005 FOR PANEL CUTOUTS.

BLIND MATE

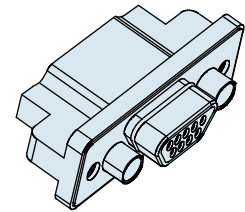

SHELL SIZES H, L
+/- .040 (1.02) ALLOWABLE MISALIGNMENT
FROM CENTERLINE

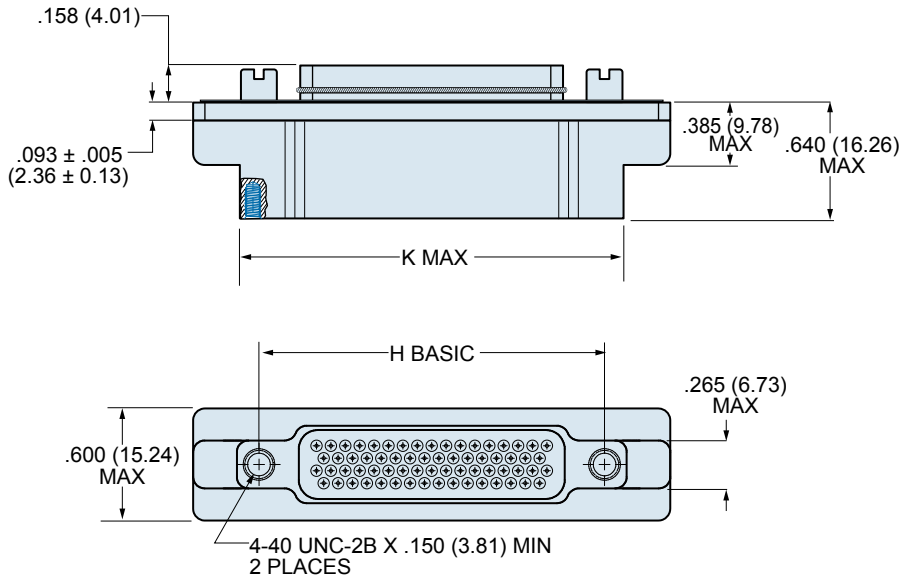

Shell Size	F Max.		G Basic		H Basic		J Max.		K Max.	
	In.	mm.	In.	mm.	In.	mm.	In.	mm.	In.	mm.
H	2.500	63.50	2.236	56.79	1.800	45.72	1.385	35.18	2.045	51.94
L	2.736	69.49	2.472	62.79	2.036	51.71	1.623	41.22	2.281	57.94

Dimensions in inches (millimeters) and are subject to change without notice.

Panel Mount Receptacles, Pin Contacts, PCB Termination, 790-028

Connectors feature machined aluminum housings, beryllium copper contact retention clips and fluorosilicone rubber seals. Silver-filled fluorosilicone panel gasket provides environmental seal to panel. Connectors are supplied with gold-plated printed circuit board contacts. Contacts are sealed with epoxy and are non-removable. Contacts are plated with 50 millionths thick gold over nickel underplate. Connector shell features integral board standoffs and threaded mounting holes.

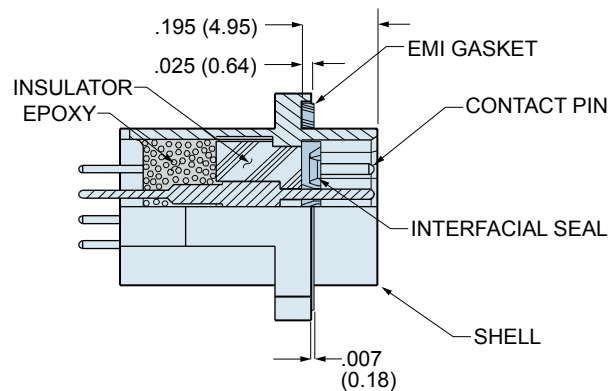

MATING HARDWARE

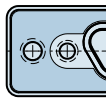

N
No Mating Hardware. See Note 1 Below.



P
Jackposts. See Note 2 Below.



G
Male Guide Pins



S
Female Guide Sockets

1. N option: connector is supplied with blind, tapped holes. Shell sizes H and L have 6-32 UNC-2B thread, other sizes are #4-40. .150" minimum thread depth.
2. P option: connector is supplied with non-removable jackposts. Shell sizes H and L have #4-40 UNC-2B thread, other sizes have #2-56 thread.

How To Order

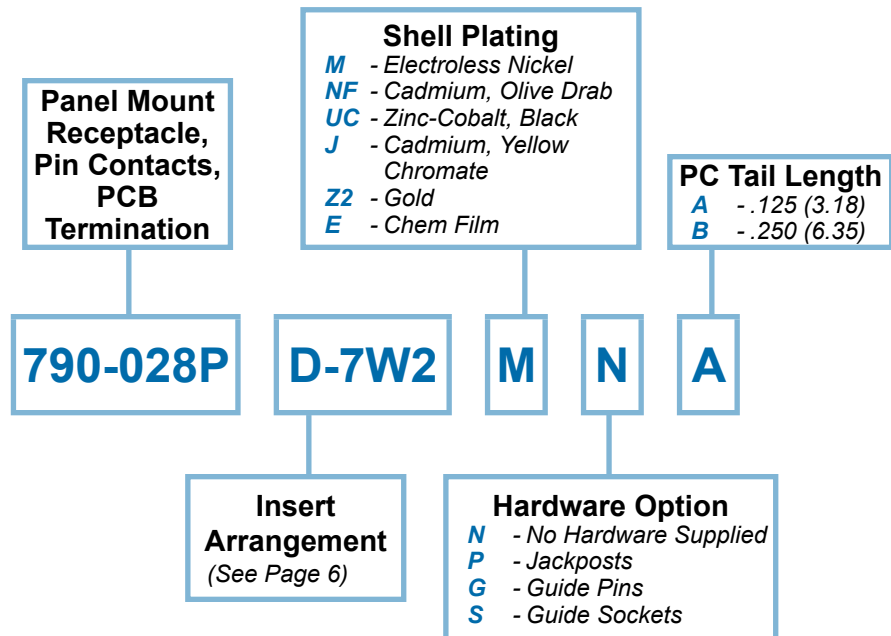

Dimensions in inches (millimeters) and are subject to change without notice.

Series 79 Micro-Crimp Micro-D for Mixed Signal, Power and Coaxial Applications



790-028P SHELL SIZE A,B,C,D,E,F,J,K DIMENSIONS

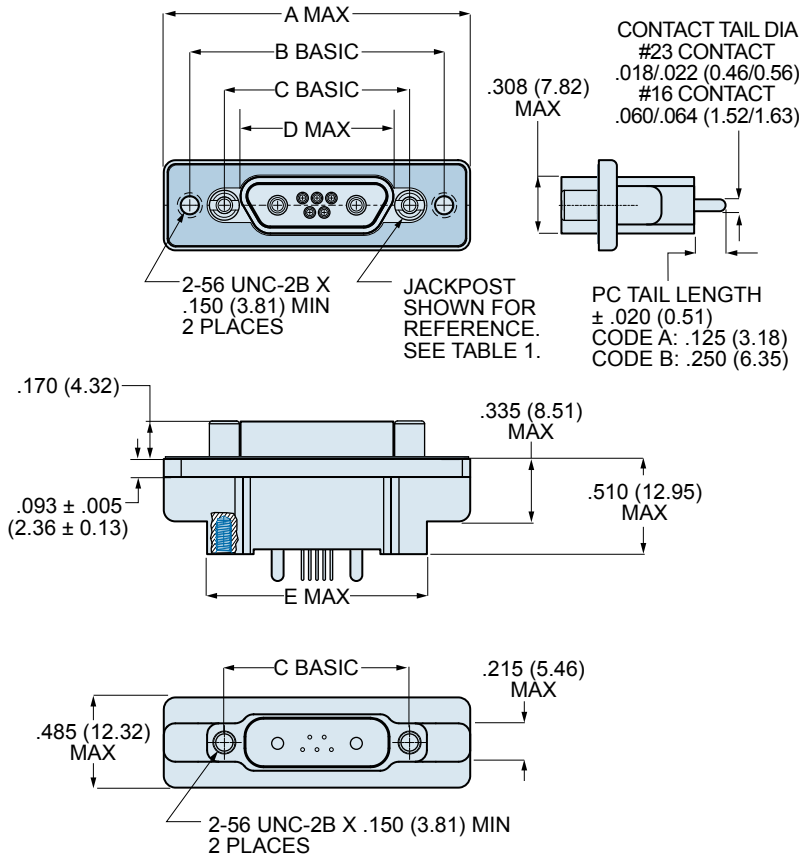

NOTES

1. REFER TO DRAWING 799-009 FOR INSERT ARRANGEMENTS.
2. REFER TO DRAWING 799-008 FOR MATERIALS, FINISHES, AND PERFORMANCE SPECIFICATIONS.
3. REFER TO DRAWING 799-010 FOR APPLICATION TOOLING INFORMATION.
4. REFER TO DRAWING 799-005 FOR PANEL CUTOUTS.
5. REFER TO DRAWING 799-004 FOR PRINTED CIRCUIT BOARD HOLE PATTERNS

BLIND MATE

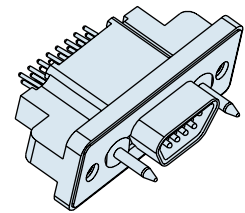

SHELL SIZES A, B, C, D, E, F, G, J, K
+/- .030 (0.76) ALLOWABLE MISALIGNMENT FROM CENTERLINE

Shell Size	A Max.		B Basic		C Basic		D Max.		E Max.	
	In.	mm.	In.	mm.	In.	mm.	In.	mm.	In.	mm.
A	1.211	30.76	.925	23.50	.565	14.35	.401	10.19	.760	19.30
B	1.361	34.57	1.075	27.31	.715	18.16	.551	14.00	.910	21.11
C	1.511	38.38	1.225	31.12	.865	21.97	.701	17.81	1.060	26.92
D	1.611	40.92	1.325	33.66	.965	24.51	.801	20.35	1.160	29.46
E	1.761	44.73	1.475	37.47	1.115	28.32	.951	24.16	1.310	33.27
F	1.911	48.54	1.625	41.28	1.265	32.13	1.101	27.96	1.460	37.08
J	2.261	57.43	1.975	50.17	1.615	41.02	1.456	36.98	1.810	45.97
K	2.661	67.59	2.375	60.33	2.015	51.18	1.860	47.24	2.210	56.13

Dimensions in inches (millimeters) and are subject to change without notice.

790-028P SHELL SIZE G DIMENSIONS

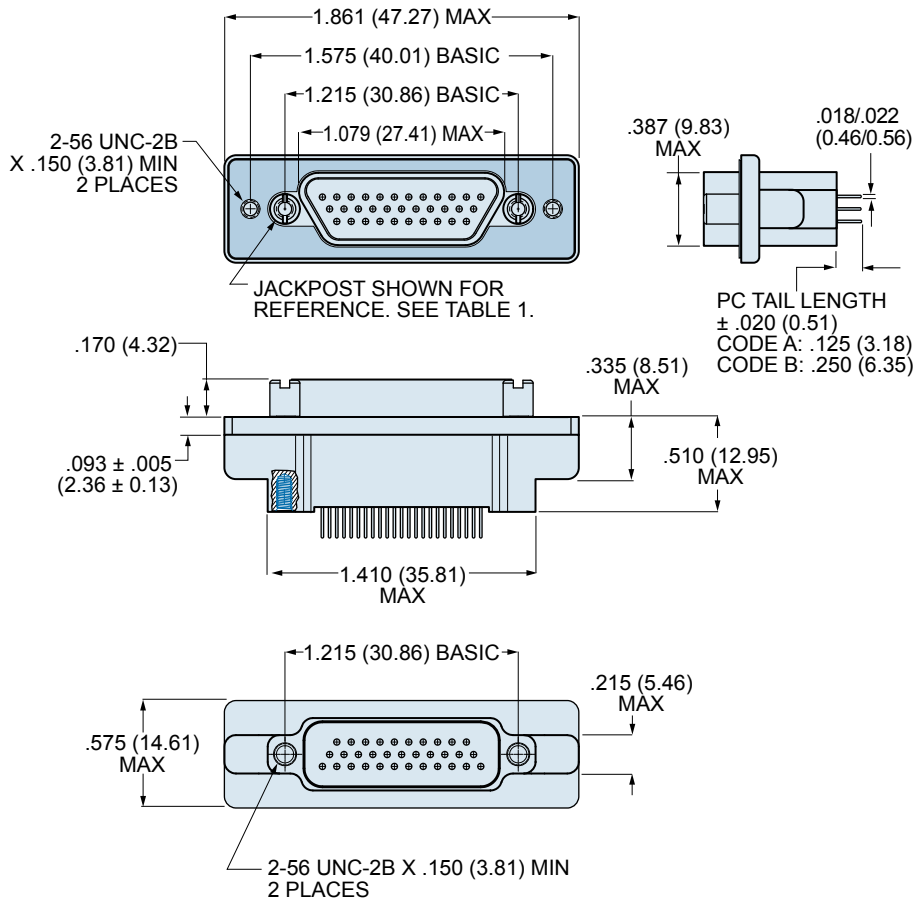

NOTES

1. REFER TO DRAWING 799-009 FOR INSERT ARRANGEMENTS.
2. REFER TO DRAWING 799-008 FOR MATERIALS, FINISHES, AND PERFORMANCE SPECIFICATIONS.
3. REFER TO DRAWING 799-010 FOR APPLICATION TOOLING INFORMATION.
4. REFER TO DRAWING 799-005 FOR PANEL CUTOUTS.
5. REFER TO DRAWING 799-004 FOR PRINTED CIRCUIT BOARD HOLE PATTERNS

BLIND MATE

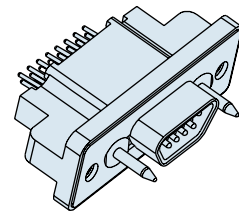

SHELL SIZES A, B, C, D, E, F, G, J, K
+/- .030 (0.76) ALLOWABLE MISALIGNMENT FROM CENTERLINE

Dimensions in inches (millimeters) and are subject to change without notice.

Series 79 Micro-Crimp Micro-D for Mixed Signal, Power and Coaxial Applications



Series 79

790-028P SHELL SIZE H, L DIMENSIONS

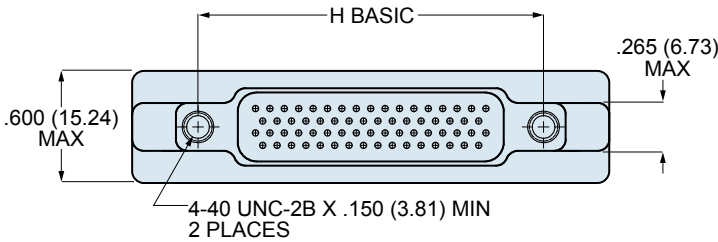
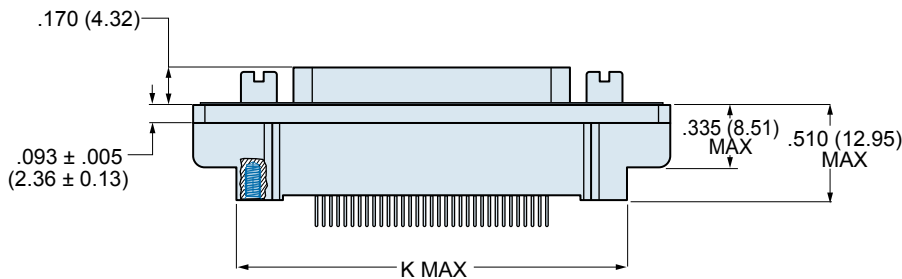
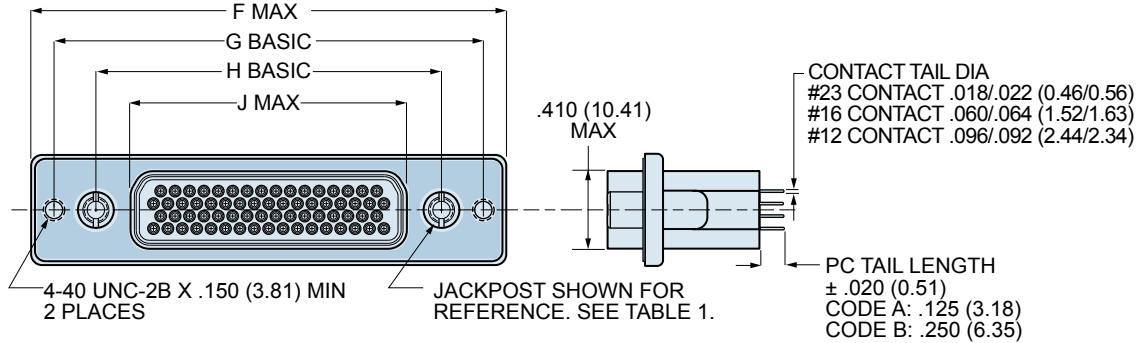

NOTES

1. REFER TO DRAWING 799-009 FOR INSERT ARRANGEMENTS.
2. REFER TO DRAWING 799-008 FOR MATERIALS, FINISHES, AND PERFORMANCE SPECIFICATIONS.
3. REFER TO DRAWING 799-010 FOR APPLICATION TOOLING INFORMATION.
4. REFER TO DRAWING 799-005 FOR PANEL CUTOUTS.
5. REFER TO DRAWING 799-004 FOR PRINTED CIRCUIT BOARD HOLE PATTERNS

BLIND MATE

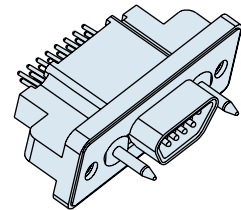

SHELL SIZES H, L
+/- .040 (1.02) ALLOWABLE MISALIGNMENT
FROM CENTERLINE

Shell Size	F Max.		G Basic		H Basic		J Max.		K Max.	
	In.	mm.	In.	mm.	In.	mm.	In.	mm.	In.	mm.
H	2.500	63.50	2.236	56.79	1.800	45.72	1.450	36.83	2.045	51.94
L	2.736	69.49	2.472	62.79	2.036	51.71	1.686	42.82	2.281	57.94

Dimensions in inches (millimeters) and are subject to change without notice.

Panel Mount Plugs, Socket Contacts, PCB Termination, 790-029S

Connectors feature machined aluminum housings, beryllium copper contact retention clips and fluorosilicone rubber seals. Silver-filled fluorosilicone panel gasket provides environmental seal to panel. Connectors are supplied with gold-plated printed circuit board contacts. Contacts are sealed with epoxy and are non-removable. Contacts are plated with 50 millionths thick gold over nickel underplate. Connector shell features integral board standoffs and tapped mounting holes.

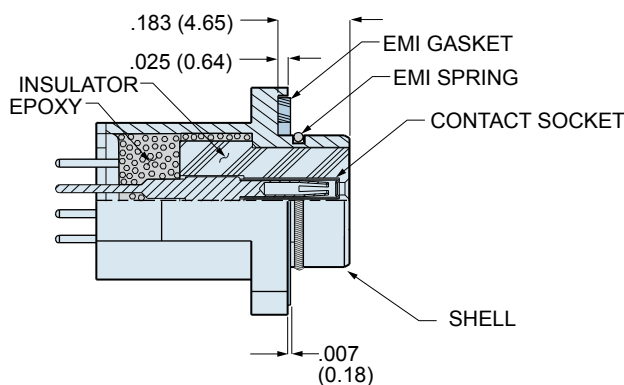

MATING HARDWARE

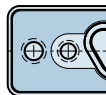

N
No Mating Hardware. See Note 1 Below.



P
Jackposts. See Note 2 Below.

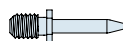

G
Male Guide Pins



S
Female Guide Sockets

1. N option: connector is supplied with blind, tapped holes. Shell sizes H and L have 6-32 UNC-2B thread, other sizes are #4-40. .150" minimum thread depth.
2. P option: connector is supplied with non-removable jackposts. Shell sizes H and L have #4-40 UNC-2B thread, other sizes have #2-56 thread.

How To Order

Panel Mount Plug, Socket Contacts, PCB Termination

Shell Plating

M - Electroless Nickel
NF - Cadmium, Olive Drab
UC - Zinc-Cobalt, Black
J - Cadmium, Yellow Chromate
Z2 - Gold
E - Chem Film

PC Tail Length

A - .125 (3.18)
B - .250 (6.35)

790-029S

F-23

M

E

P

B

Insert Arrangement
(See Page 6)

EMI Spring

N - No Spring
E - EMI Spring
(EMI Spring requires Electroless Nickel, Gold or Chem Film Shell Plating)

Hardware Option

N - No Hardware
P - Jackposts
G - Guide Pins
S - Guide Sockets

Dimensions in inches (millimeters) and are subject to change without notice.

Series 79 Micro-Crimp Micro-D for Mixed Signal, Power and Coaxial Applications



790-029S SHELL SIZE A,B,C,D,E,F,J,K DIMENSIONS

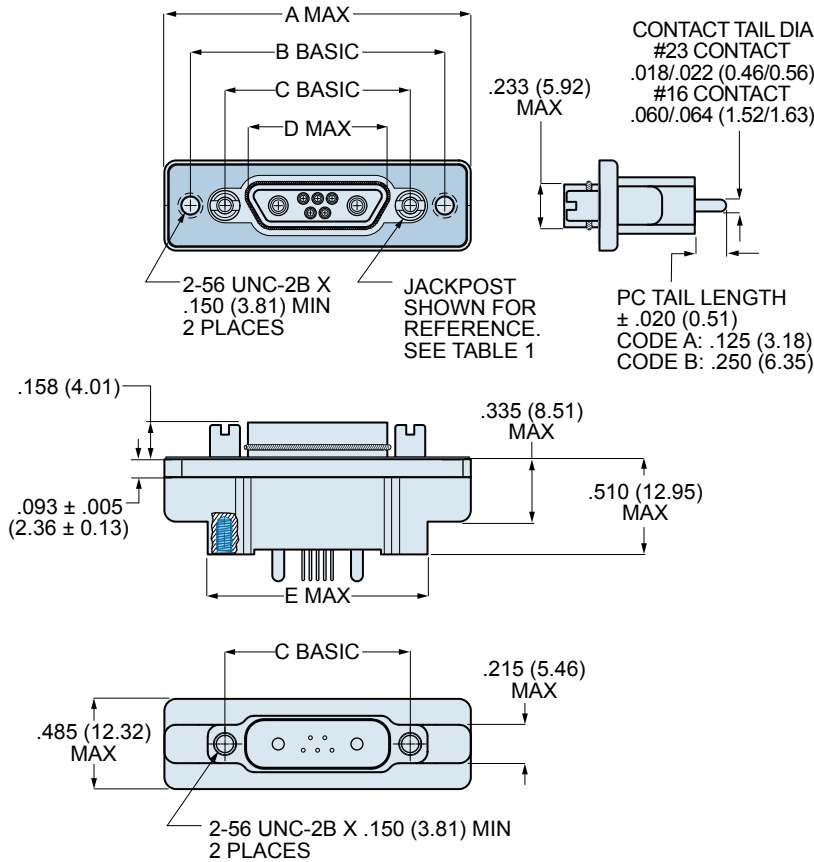

NOTES

1. REFER TO DRAWING 799-009 FOR INSERT ARRANGEMENTS.
2. REFER TO DRAWING 799-008 FOR MATERIALS, FINISHES, AND PERFORMANCE SPECIFICATIONS.
3. REFER TO DRAWING 799-010 FOR APPLICATION TOOLING INFORMATION.
4. REFER TO DRAWING 799-005 FOR PANEL CUTOUTS.
5. REFER TO DRAWING 799-004 FOR PRINTED CIRCUIT BOARD HOLE PATTERNS.
6. GROUND SPRING IS AVAILABLE ONLY WITH NICKEL, GOLD OR CHEM FILM PLATING ON THE SHELL.

BLIND MATE

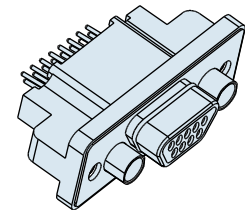

SHELL SIZES A, B, C, D, E, F, G, J, K
+/- .030 (0.76) ALLOWABLE
MISALIGNMENT FROM CENTERLINE

Shell Size	A Max.		B Basic		C Basic		D Max.		E Max.	
	In.	mm.	In.	mm.	In.	mm.	In.	mm.	In.	mm.
A	1.211	30.76	.925	23.50	.565	14.35	.335	8.51	.760	19.30
B	1.361	34.57	1.075	27.31	.715	18.16	.485	12.32	.910	21.11
C	1.511	38.38	1.225	31.12	.865	21.97	.635	16.13	1.060	26.92
D	1.611	40.92	1.325	33.66	.965	24.51	.735	18.67	1.160	29.46
E	1.761	44.73	1.475	37.47	1.115	28.32	.885	22.48	1.310	33.27
F	1.911	48.54	1.625	41.28	1.265	32.13	1.035	26.29	1.460	37.08
J	2.261	57.43	1.975	50.17	1.615	41.02	1.390	35.31	1.810	45.97
K	2.661	67.59	2.375	60.33	2.015	51.18	1.795	45.59	2.210	56.13

Dimensions in inches (millimeters) and are subject to change without notice.

790-029S SHELL SIZE G DIMENSIONS

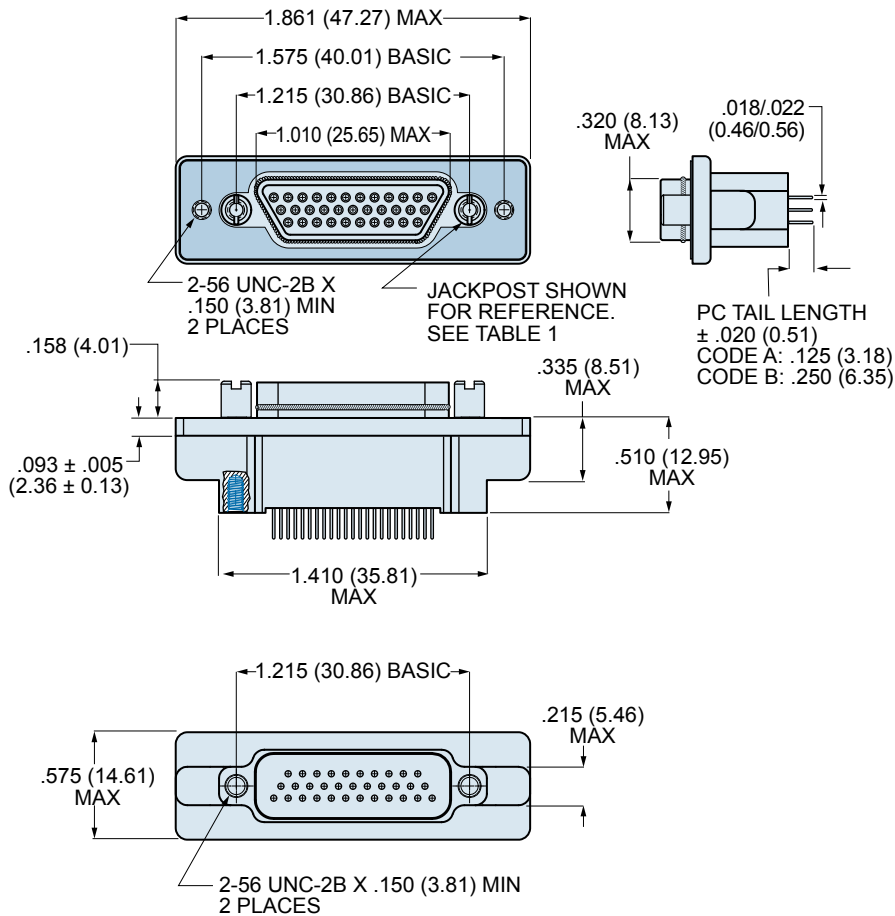

NOTES

1. REFER TO DRAWING 799-009 FOR INSERT ARRANGEMENTS.
2. REFER TO DRAWING 799-008 FOR MATERIALS, FINISHES, AND PERFORMANCE SPECIFICATIONS.
3. REFER TO DRAWING 799-010 FOR APPLICATION TOOLING INFORMATION.
4. REFER TO DRAWING 799-005 FOR PANEL CUTOUTS.
5. REFER TO DRAWING 799-004 FOR PRINTED CIRCUIT BOARD HOLE PATTERNS.
6. GROUND SPRING IS AVAILABLE ONLY WITH NICKEL, GOLD OR CHEM FILM PLATING ON THE SHELL.

BLIND MATE

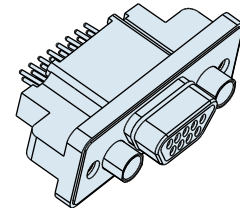

SHELL SIZES A, B, C, D, E, F, G, J, K
+/- .030 (0.76) ALLOWABLE
MISALIGNMENT FROM CENTERLINE

Dimensions in inches (millimeters) and are subject to change without notice.

Series 79 Micro-Crimp Micro-D for Mixed Signal, Power and Coaxial Applications



Series 79

790-029S SHELL SIZE H AND L DIMENSIONS

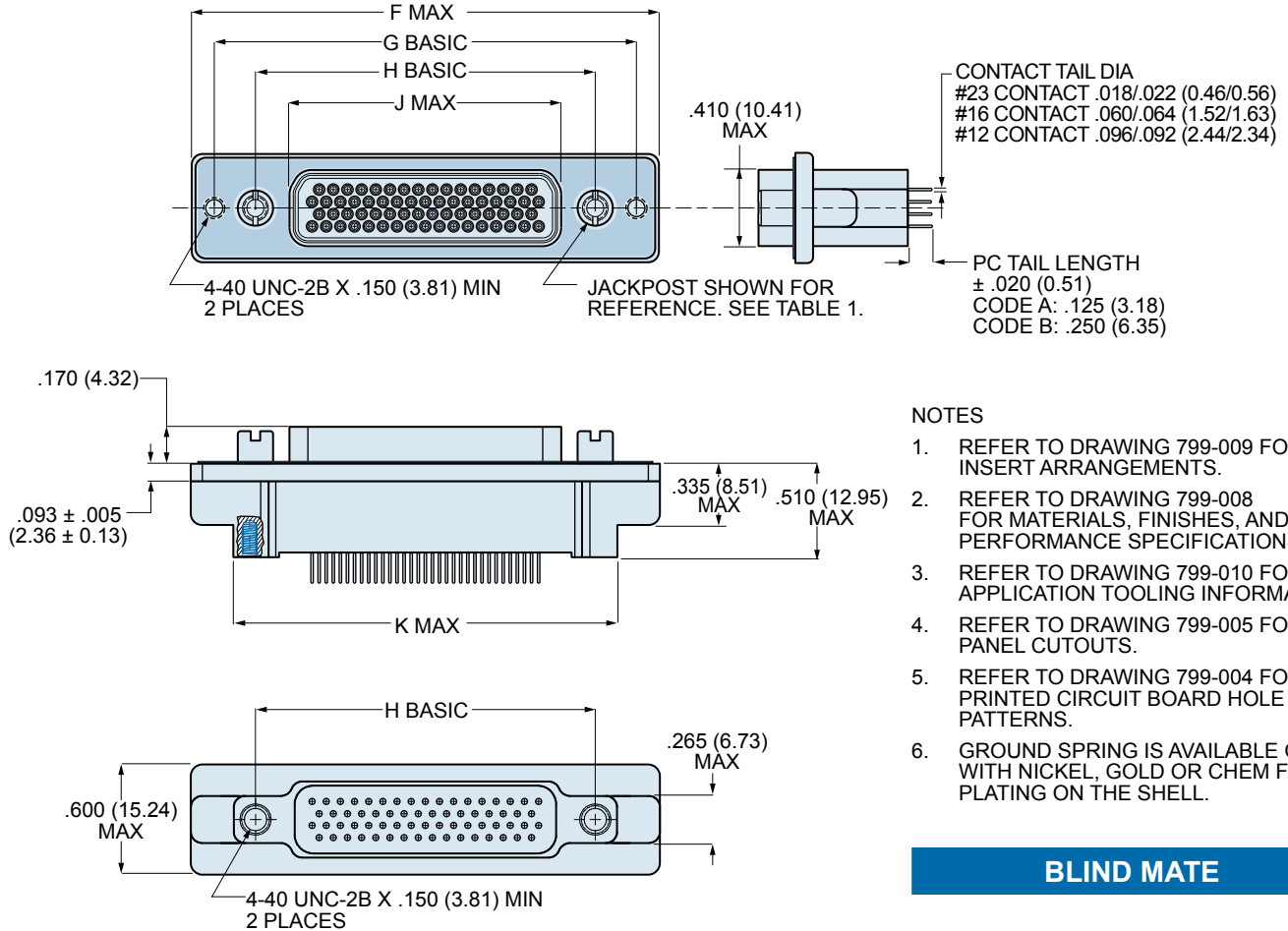

Shell Size	F Max.		G Basic		H Basic		J Max.		K Max.	
	In.	mm.	In.	mm.	In.	mm.	In.	mm.	In.	mm.
H	2.500	63.50	2.236	56.79	1.800	45.72	1.385	35.18	2.045	51.94
L	2.736	69.49	2.472	62.79	2.036	51.71	1.623	41.22	2.281	57.94

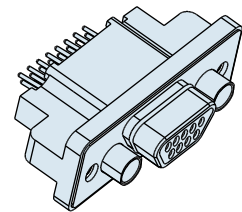

SHELL SIZES H, L
+/- .040 (1.02) ALLOWABLE MISALIGNMENT
FROM CENTERLINE

Dimensions in inches (millimeters) and are subject to change without notice.

RECOMMENDED PANEL CUTOUTS

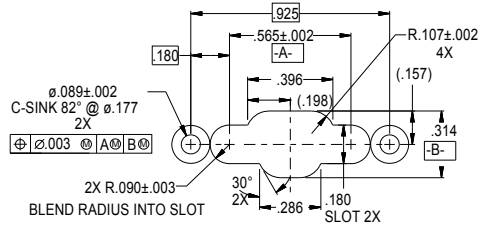

Shell Size A

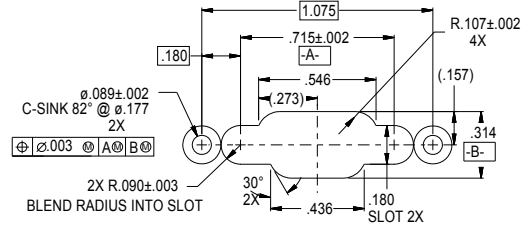

Shell Size B

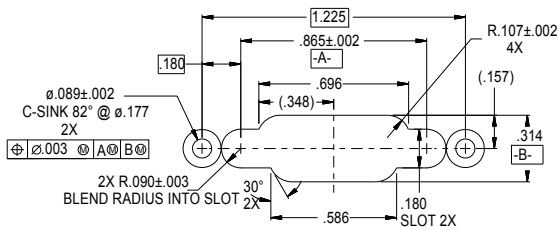

Shell Size C

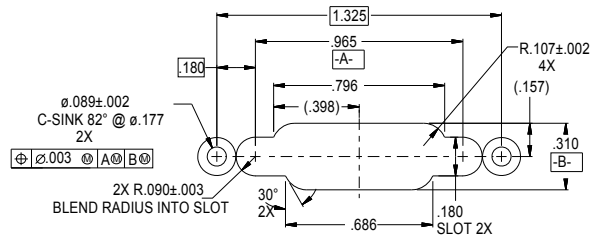

Shell Size D

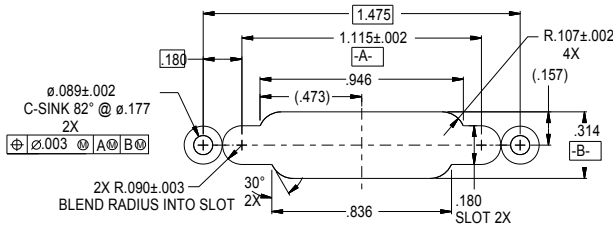

Shell Size E

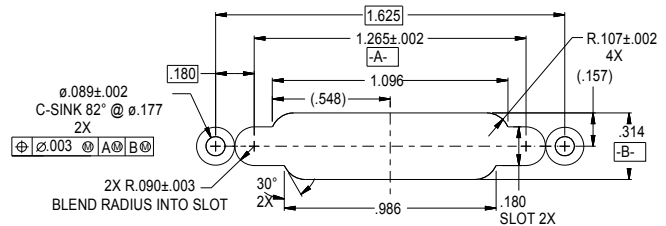

Shell Size F

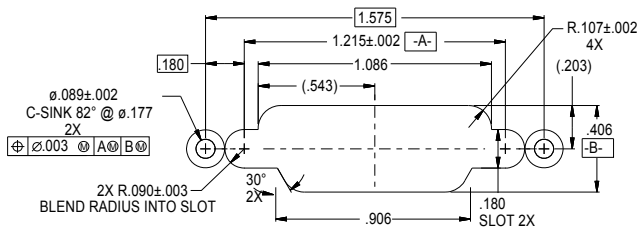

Shell Size G

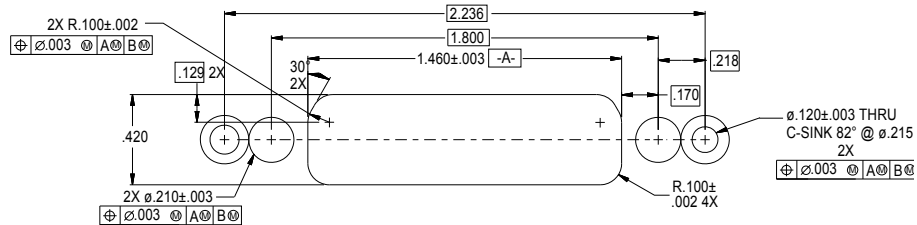

Shell Size H

Dimensions in inches (millimeters) and are subject to change without notice.

CAGE Code 06324

Printed in U.S.A.

RECOMMENDED PANEL CUTOUTS

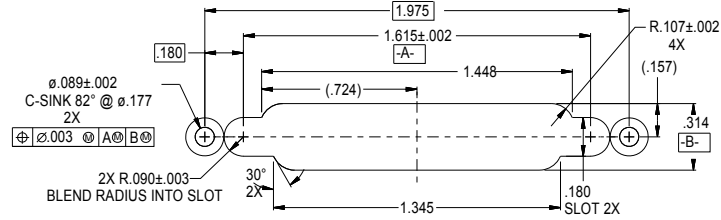

Shell Size J

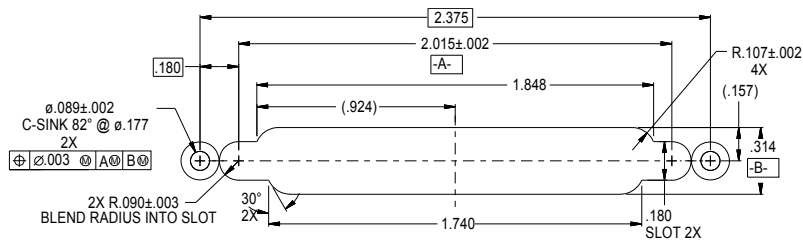

Shell Size K

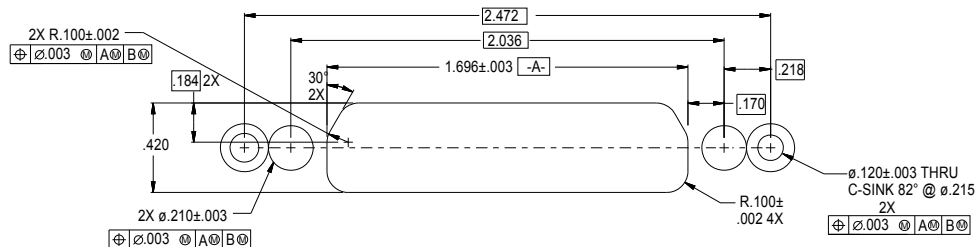

Shell Size L

Dimensions in inches (millimeters) and are subject to change without notice.

Series 79 "Micro-Crimp" Printed Circuit Board Connectors

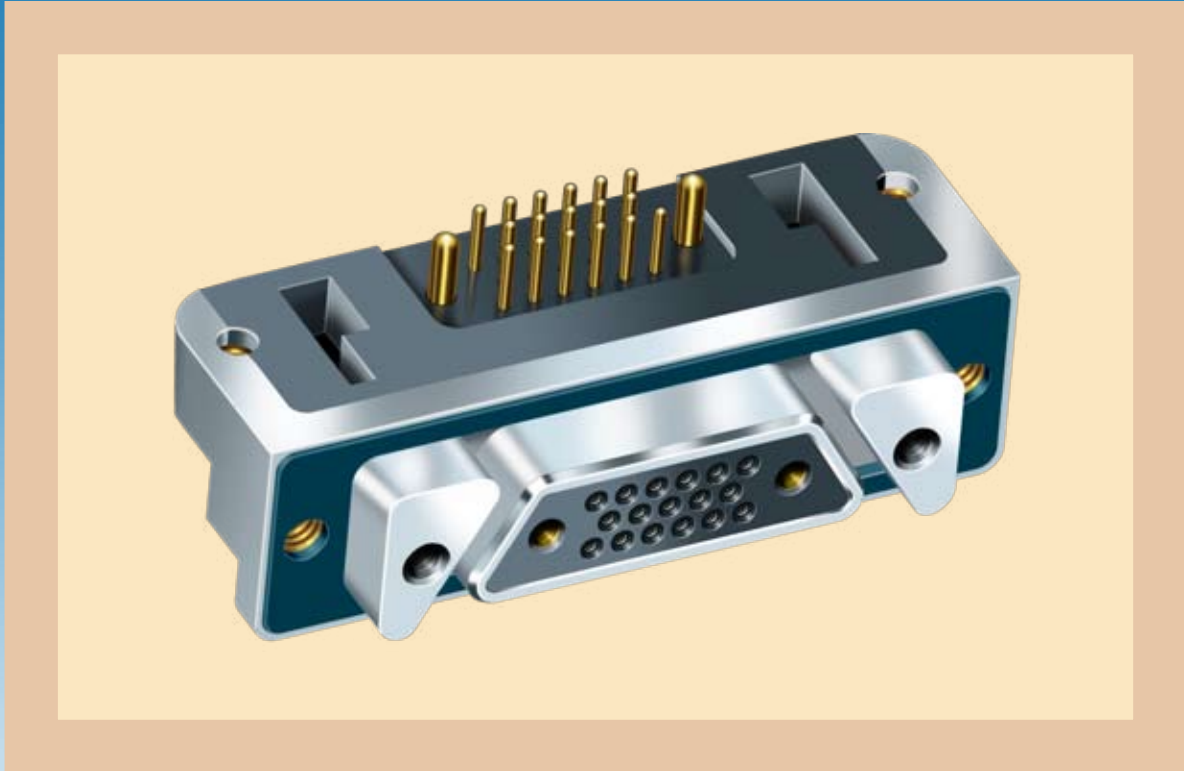

Available Soon.
Consult the Factory.

Glenair is committed to bringing full-spectrum "No-Gap" product lines to market. We understand that in many ways an innovative connector series, such as the "Micro-Crimp," is only truly useful to our customers if it offers the full range of connector styles, tools, and accessories. That's why we are hard at work at Glenair putting the finishing

touches on our PCB mount versions of the "Micro-Crimp" together with a targeted range of shield termination backshells and other accessories.

Most customers have a simple expectation: fast and accurate service. But we know you also wouldn't mind if we anticipated some of your other needs, such as building all the right parts for both cable-to-cable *and* cable-to-board applications.



1211 Air Way

Glendale, California 91201-2497

Telephone: 818-247-6000 · Facsimilie: 818-500-9912 · EMail: sales@glenair.com

United States · United Kingdom · Germany · Nordic · France · Italy · Spain · Japan

www.glenair.com

MILLIMETERS - NEWTONS

SPECIFICATION 799-008
REVISION 2
20 MARCH 2008

SUPERCEDING
REVISION 1

PRODUCT SPECIFICATION SERIES 79 "MICRO-CRIMP" CONNECTORS



CONNECTORS, MICROMINIATURE ENVIRONMENTAL, RECTANGULAR, RECEPTACLES AND PLUGS, GENERAL SPECIFICATION FOR

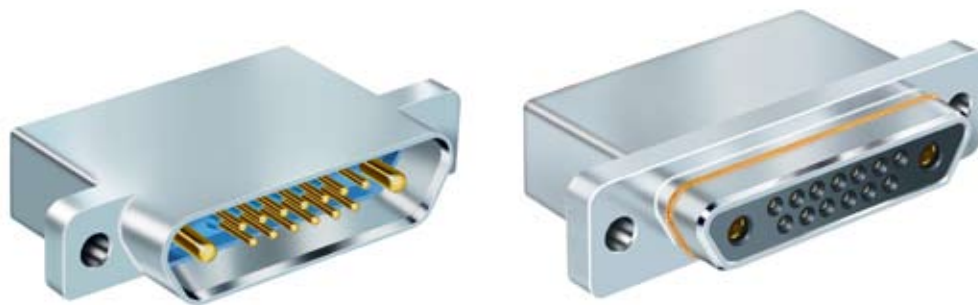

DISTRIBUTION STATEMENT: General release, unlimited distribution

© 2008 Glenair, Inc. All Rights Reserved.

Dimensions in inches (millimeters) and are subject to change without notice.

© 2008 Glenair, Inc.

CAGE Code 06324

Printed in U.S.A.

GLENAIR, INC. • 1211 AIR WAY • GLENDALE, CA 91201-2497 • 818-247-6000 • FAX 818-500-9912

www.glenair.com

41

E-Mail: sales@glenair.com

SCOPE

- 1.1 Scope. This specification covers performance requirements for Glenair Series 79 CB microminiature rectangular connectors.
- 1.2 Description. Series 79 connectors with crimp, rear-release or non-removable printed circuit board contacts, environmental sealing, aluminum and corrosion resistant steel shells, friction coupling. Series 79 connectors combine M83513 type shells with M39029 type contact systems. Interfacial seal and rear grommet provide environmental protection. Beryllium copper contact retention clips.

1 APPLICABLE DOCUMENTS

1.1 Industrial Standards.

EIA-364	Electrical Connector/Socket Test Procedures Including Environmental Classifications
IEC-60512	Electromechanical Components for Electronic Equipment; Basic Testing Procedures and Measuring Methods Part 1: General
IEC-60529	Degrees of protection Provided By Enclosures (IP Code)
IEC 60068	Environmental Testing Part 1: General and Guidance

1.2 Military Standards and Specifications

MIL-STD-810F	Test Method Standard for Environmental Engineering Considerations and Laboratory Tests
MIL-DTL-83513	Connectors, Electrical, Rectangular, Microminiature, Polarized Shell, General Specification

1.3 Aerospace Standards

SAE AS39029	Contacts, Electrical Connector, General Specification For
-------------	---

2 REQUIREMENTS

2.1 Ratings

Voltage(DWV): #23 contacts 500 Volts AC. #12 and #16 contacts 1800 Volts AC
 Current: #23 contact 5 amperes, #16 contact 13 amperes, #12 contact 23 amperes.
 Temperature: -65° C to +200° C.

Dimensions in inches (millimeters) and are subject to change without notice.

2.2 Materials

DESCRIPTION	MATERIAL	FINISH
#23 Contacts	Beryllium copper	Gold plated 50 microinches minimum over nickel underplate.
#12 and #16 Contacts	Copper alloy	Gold plated 50 microinches minimum over nickel underplate.
Socket Contact Hood	Stainless steel	Passivated
Shells	Aluminum alloy 6061	Code C: black anodize per MIL-A-8625 Code M: electroless nickel per ASTM B-733 Code NF: Olive drab cadmium per AMS-QQ-P-416 over electroless nickel Code E: Chem film per MIL-DTL-5541 Code J: Yellow chromate over cadmium per AMS-QQ-P-416 Code UC: Black zinc cobalt
Insulators	Liquid crystal polymer (LCP) per MIL-M-24519	None
Interfacial seals, grommets	Fluorosilicone elastomer	None
EMI spring	Stainless Steel	Gold plated
Contact retention clip, insert assembly retention clip	Beryllium copper	None
Jackscrews, jackposts, washers, threaded inserts, nuts	300 series stainless steel	passivated

Dimensions in inches (millimeters) and are subject to change without notice.

2.3 Performance requirements.

DESCRIPTION	REQUIREMENT	PROCEDURE
ELECTRICAL		
Contact resistance	SAE AS39029 Table V Max Wire Test Voltage Size Current Drop 12 23 42 14 17 40 16 13 49 20 7.5 55 22 5 73 24 3 45 26 2 52 28 1.5 54	EIA-364-06 IEC 60512-2-1 Test current in amperes. Voltage drop in millivolts. Silver-coated copper wire, +25°C.
Low Level Contact Resistance	Wire Max. Size Milliohms 16 5 20 9 22 15 24 20 26 31 28 50	EIA-364-23 100 milliamperes maximum and 20 millivolts maximum open circuit voltage
Insulation resistance	5000 megohms minimum	EIA-364-21 IEC-60512-3-1 500 volts DC \pm 50 volts. Test between adjacent contacts and contacts to shell.
Dielectric withstanding voltage	No breakdown or flashover	EIA-364-20 IEC-60512-4-1 Sea level AC rms 50 or 60 Hz. One minute dwell. #23 contacts 500 volts #16 contacts 1800 volts #12 contacts 1800 volts
Current carrying capacity	Contact Max Size Current 12 23 16 13 23 5	EIA-364-70 Method 1 IEC-60512-5 Test 9b

Dimensions in inches (millimeters) and are subject to change without notice.

Series 79 Micro-Crimp Micro-D for Mixed Signal, Power and Coaxial Applications



DESCRIPTION	REQUIREMENT	PROCEDURE
Shell-to-shell resistance (connectors with ground springs)	5 millivolt drop maximum	EIA-364-83 IEC-60512-2-6 Electroless nickel plated connectors.
Shielding Effectiveness	60 dB attenuation minimum from 100MHz to 10GHz	EIA-364-66 IEC-60512-23-3
MECHANICAL		
Water Immersion	No evidence of water penetration into mated connectors. No evidence of water penetration into an unmated panel mounted PCB receptacle. $\geq 100 \text{ M}\Omega$ insulation resistance.	MIL-STD-810F Method 512.4 1 meter immersion 1 hour
Air Pressure	No detectable moisture. $\geq 100 \text{ M}\Omega$ insulation resistance.	IEC-60512-7 Test 14b 0.4 bar overpressure 48 hours immersion at a depth of 150mm in 25° C tap water.
Ingress Protection	IP67 rating	IEC-60529
Vibration, Sine	No discontinuity of greater than 1 microseconds, no cracking, breaking or loosening of parts, plug shall not become disengaged from receptacle. Connectors shall meet electrical requirements after vibration test.	EIA-364-28 Test Condition IV IEC-60512-6-4 100 milliamp test current 10- 2,000 Hz 20 g, 196 m/s ²
Vibration, Random	No discontinuity of greater than 1 microseconds, no cracking, breaking or loosening of parts, plug shall not become disengaged from receptacle. Connectors shall meet electrical requirements after vibration test.	EIA-364-28 Test Condition VI Letter J IEC-60512-6-4 100 milliamp test current 50- 2,000 Hz 43.92 g rms
Mechanical Shock	No discontinuity of greater than 1 microsecond, no cracking, breaking or loosening of parts, plug shall not become disengaged from receptacle. Connectors shall meet electrical requirements after shock test.	EIA-364-27 Condition D IEC-60512-6-3 3 shocks X 3 axes X 2 directions = 18 shocks 2941 m/s ² (300 g's), 3 ms, half-sine

Dimensions in inches (millimeters) and are subject to change without notice.

Series 79 Micro-Crimp Micro-D for Mixed Signal, Power and Coaxial Applications

DESCRIPTION	REQUIREMENT	PROCEDURE
Thermal Shock	No mechanical damage or loosening of parts. Following thermal shock, connector shall meet contact resistance, DWV, insulation resistance and shell-to-shell resistance requirements.	EIA-364-32 Test Condition IV IEC-60512-11-4 5 cycles consisting of -65° C 30 minutes, +25° C 5 minutes max., +150° C 30 minutes, +25° C 5 minutes max.
Humidity, Cyclic (Damp Heat, Cyclic) (Moisture Resistance)	No deterioration which will adversely affect the connector. 100 megohms minimum insulation resistance during the final cycle. Following the recovery period, connectors shall meet contact resistance, shell-to-shell resistance and DWV requirements.	EIA-364-31 Condition B Method III IEC-60512-11-12 80-98% RH 10 cycles (10 days) +25° C to +65° C Step 7b vibration deleted. 24 hour recovery period.
21 Day Humidity (Damp heat, Long Term)	No deterioration which will adversely affect the connector. Following the drying period, connectors shall meet 100 megohms minimum, contact resistance, shell-to-shell resistance, DWV, mating and unmating requirements.	EIA-364-31 Condition C Method II IEC-60512-11-3 Severity C 90-95% RH 40° C Apply 100 volts DC during test. 4 hours drying time at ambient temperature prior to final measurements.
Mechanical Durability, at Ambient Temperature	No deterioration which will adversely affect the connector after 2000 cycles of mating and unmating. Connectors shall meet contact resistance, insulation resistance, shell-to-shell resistance, DWV, and mating and unmating force.	EIA-364-09 IEC-60512-5 Test 9a
Corrosion (Salt Mist)	No exposure of base metal. Connectors shall meet DWV and contact resistance requirements following the test.	EIA-364-26 IEC 60512-11-6 5% salt solution 35° C Unmated connectors Code C: black anodize 48 hours Code M: electroless nickel 48 hours Code NF: Olive drab cadmium over electroless nickel 500 hours Code E: Chem film 48 hours Code J: Yellow chromate over cadmium 48 hours Code ZNU: Black zinc nickel 500 hours

Dimensions in inches (millimeters) and are subject to change without notice.

Series 79 Micro-Crimp Micro-D for Mixed Signal, Power and Coaxial Applications



DESCRIPTION	REQUIREMENT	PROCEDURE															
Solderability, PC Tail Contacts	95% solder coverage. Smooth, bright and even finish.	EIA-364-52 Category 3 IEC-60512-12-1 IEC-68-2-20 Test Ta, method 1 8 hours steam aging prior to test 245° C 4-5 sec. dwell 10X magnification															
Resistance To Soldering Heat	No damage to connector. Connectors shall meet insulation resistance and waterproof sealing requirements.	EIA-364-56 IEC-60512-12-5 Test 12e 260° C, 10 seconds (PC tail)															
Impact, Cable Connectors	No impairment of function. Connector shall meet contact resistance, insulation resistance and waterproof sealing.	EIA-364-42 IEC-60512-5 test 7b 1 meter 8 drops															
Fluid Immersion	No damage from immersion in various fuels and oils. Connector shall meet mating/unmating force and dielectric withstanding voltage.	EIA-364-10															
Altitude Immersion	No evidence of moisture on connector interface or contacts. Connector shall meet dielectric withstanding voltage.	EIA-364-03 Wired connectors with supplemental potting.															
Contact Retention	<table border="1"> <thead> <tr> <th>Contact Size</th> <th>Min. Pounds</th> <th>Min. Newtons</th> </tr> </thead> <tbody> <tr> <td>23</td> <td>6</td> <td>27</td> </tr> <tr> <td>20</td> <td>15</td> <td>67</td> </tr> <tr> <td>16</td> <td>25</td> <td>111</td> </tr> <tr> <td>12</td> <td>25</td> <td>111</td> </tr> </tbody> </table>	Contact Size	Min. Pounds	Min. Newtons	23	6	27	20	15	67	16	25	111	12	25	111	EIA-364-29
Contact Size	Min. Pounds	Min. Newtons															
23	6	27															
20	15	67															
16	25	111															
12	25	111															
Contact Separation Force	<table border="1"> <thead> <tr> <th>Contact Size</th> <th>Min. Ounces</th> <th>Min. Newtons</th> </tr> </thead> <tbody> <tr> <td>23</td> <td>0.5</td> <td>0.14</td> </tr> <tr> <td>20</td> <td>0.7</td> <td>0.19</td> </tr> <tr> <td>16</td> <td>2.0</td> <td>0.56</td> </tr> <tr> <td>12</td> <td>3.0</td> <td>0.83</td> </tr> </tbody> </table>	Contact Size	Min. Ounces	Min. Newtons	23	0.5	0.14	20	0.7	0.19	16	2.0	0.56	12	3.0	0.83	SAE AS39029
Contact Size	Min. Ounces	Min. Newtons															
23	0.5	0.14															
20	0.7	0.19															
16	2.0	0.56															
12	3.0	0.83															
Mating and Unmating Force	Maximum Mating/unmating force: (6 pounds) + (# of size 23 contacts X .35) + (# of size 12 or #16 contacts X 1.8)	EIA-364-13															
Residual Magnetism	2 μ maximum.	EIA-364-54															

Dimensions in inches (millimeters) and are subject to change without notice.



A World of Interconnect Solutions

Glenair, Inc.

1211 Air Way • Glendale, California • 91201-2497
Telephone: 818-247-6000 • Fax: 818-500-9912 • sales@glenair.com
www.glenair.com

**Glenair Industrial Power and
Signal Connector Group** Telephone: 203-741-1115
25 Village Lane Facsimile:
Wallingford, CT 203-741-0053
06492 sales@glenair.com

Glenair UK Ltd Telephone: 44-1623-638100
40 Lower Oakham Way Facsimile:
Oakham Business Park 44-1623-638111
P.O. Box 37, Mansfield sales@glenair.co.uk
Notts, NG18 5BY England

Glenair Microway Systems Telephone: 847-679-8833
7000 North Lawndale Avenue Facsimile:
Lincolnwood, IL 847-679-8849
60712

Glenair Nordic AB Telephone: 46-8-50550000
Gustav III : S Boulevard 46 Facsimile:
S - 169 27 Solna 46-8-50550001
Sweden sales@glenair.se

Glenair Electric GmbH Telephone: 49-6171-5905-0
Siemensstrasse 9 Facsimile:
D-61449 Steinbach 49-6171-5905-90
Germany germany@glenair.com

Glenair Iberica Telephone: 34-925-89-29-88
C/ La Vega, 16 Facsimile:
45612 Velada 34-925-89-29-87
Spain sales@glenair.es

Glenair Italia S.R.L. Telephone: 39-02-91082121
Via Santi, 1 Facsimile:
20037 Paderno Dugnano 39-02-99043565
Milano, Italy sales-italia@glenair.it

Glenair France SARL Telephone: 33-5-34-40-97-40
7, Avenue Parmentier Facsimile:
Immeuble Central Parc #2 33-5-61-47-86-10
31200 Toulouse sales@glenair.fr
France

