

CONNECTOR
DESIGNATORS

A-B*-C-D-E-F
G-H-J-K-L-S

* Conn. Desig. B See Note 5
DIRECT COUPLING

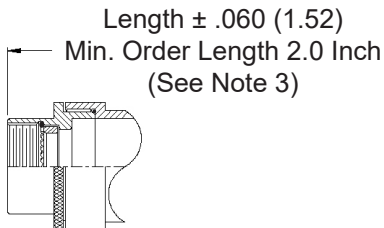
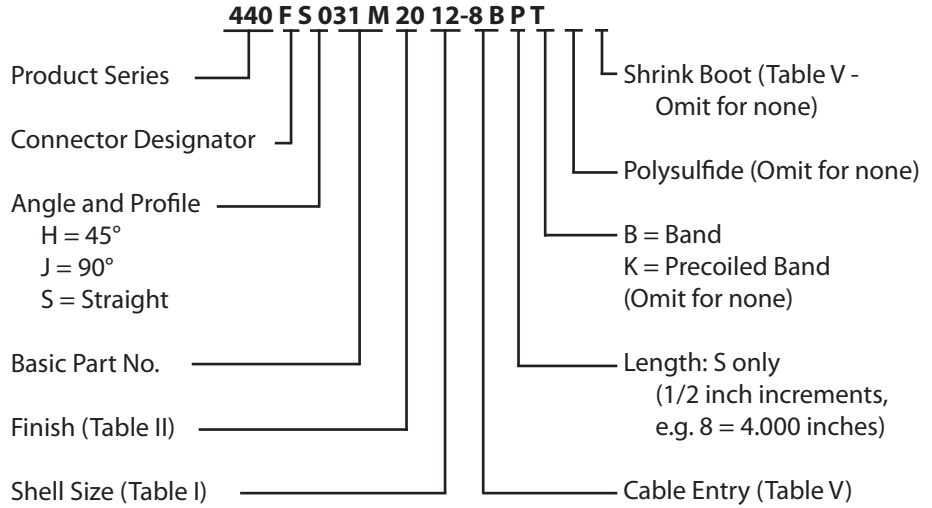

STYLE 2
(STRAIGHT)
See Note 1)

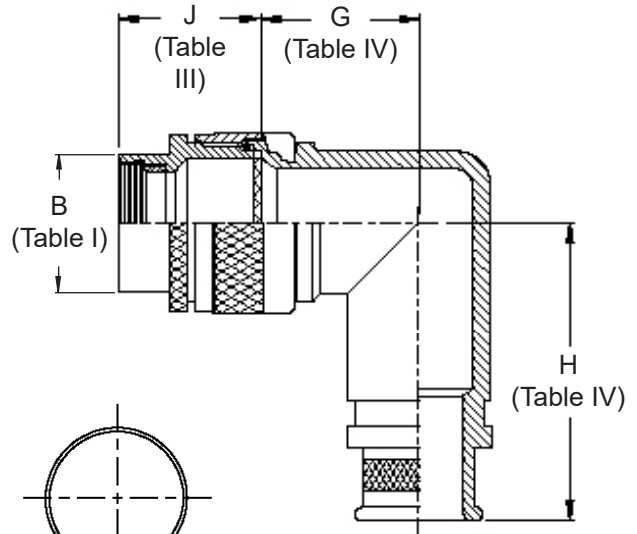
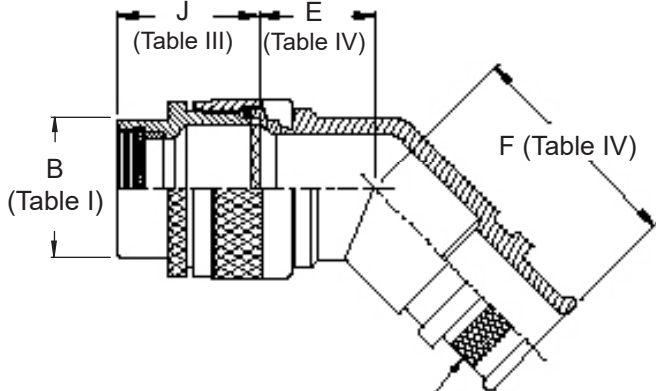
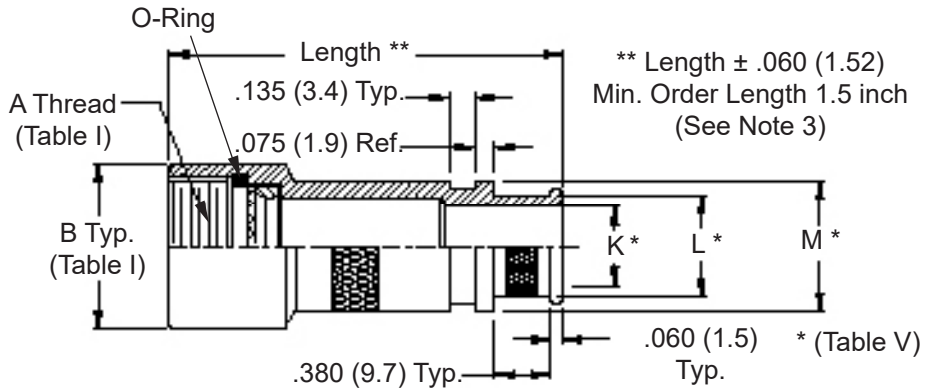

Termination Area
Nickel Plated. Knurl or
Ridges Mfr's Option

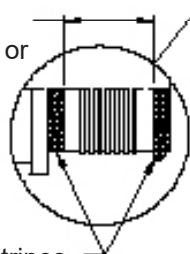

Polysulfide Stripes
P Option

Band Option
(K Option Shown -
See Note 6)

