



## CRYSTAL SPECIFICATION

CUSTOMER / Rep. / Dist. : SHOPPING CART  
CUSTOMER PART NO. : 1610K3276BMCB  
PRODUCT CODE : 1610K3276BMCB  
PRODUCT DESCRIPTION : TUNING FORK SMD CRYSTAL 1.6x1.0mm TYPE

Customer Approval :

Hong Kong X'tals Limited



Unit C, 24/F, Shield Industrial Centre,  
84 - 92 Chai Wan Kok Street,  
Tsuen Wan, New Territories, Hong Kong.

Fax: (852) 3511 2420  
Phone: (852) 3511 2388  
Email: [hkxtals@HongKongCrystal.com](mailto:hkxtals@HongKongCrystal.com)  
Website: [www.hongkongcrystal.com](http://www.hongkongcrystal.com)

Date : 26/03/2021

Approved by :

Mr. Ronald Chan / Product Engineer

# CRYSTAL SPECIFICATION

Product Code : 1610K3276BMCB

Description : Quartz Crystal

## Revision History

Rev.	Date	Reason	Issued By
0	25/03/2021		Celia Cheung

# **CRYSTAL SPECIFICATION**

Customer / Rep. / Dist. : SHOPPING CART  
Customer Part No. : 1610K3276BMCB  
Product Code : 1610K3276BMCB  
Description : Quartz Crystal  
Nominal Frequency : 32.768 KHz  
Oscillation Mode : +2°X - Cut Fundamental  
Holder Type : MT

## Measure equipment

Electrical characteristics measured by Kolinker KH1240 equivalent.

Electrical Characteristics :

Load Capacitance	7 pF
Frequency Tolerance At 25 °C	± 20 ppm
Frequency Stability	-0.045 ppm /°C <sup>2</sup> Max.
Operating Temperature Range	-40 ~ 85 °C
Storage Temperature Range	-40 ~ 90 °C
Turnover Temperature	25°C ± 5°C
Ageing	<± 5 ppm first year
Drive Level	0.1 µW typ. (0.5 µW Max.)
Equivalent Series Resistance	90K ohms Max. at 25°C
Shunt Capacitance	2 pF Max.
Insulation Resistance	500M ohm Min/DC100V+/-15V
Marking	TRACEABILITY CODE
SPQ / Pack Type	5000 / REEL

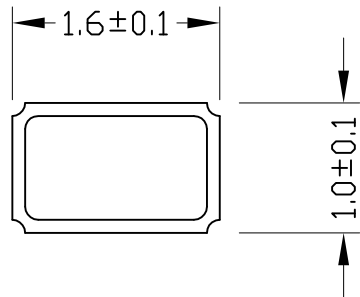

TOP VIEW

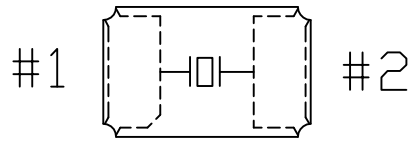

INTERNAL CONNECTION  
REMARK: 1,2 -CRYSTAL

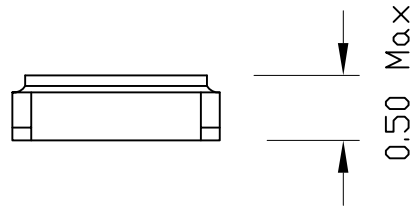

FRONT VIEW

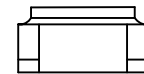

SIDE VIEW

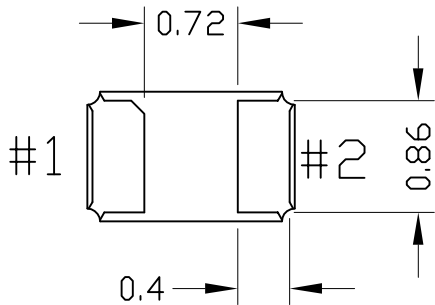

BOTTOM VIEW

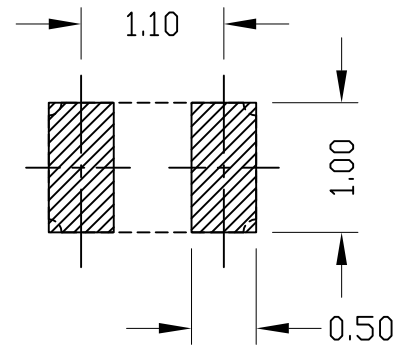

RECOMMENDED LAND PATTERN

\* Recommended no circuitry or trace in between the solder pads

MARKING INFORMATION

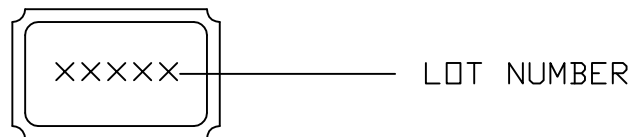

ITEM		QTY.		DESCRIPTION		MAT'L	HDN.	SURFACE	MAT'L SIZE	REMARK
GENERAL TOLERANCE:		.X=±0.1 .XX=±0.05		DATE	NAME		TITLE : 1.6x1.0 CERAMIC SMD TUNING FORK CRYSTAL			
PROPRIETARY NOTICE : THIS DRAWINGS AND SPECIFICATIONS ARE THE PROPERTY OF HKC.		DRAWN	2015-7-15	TAN	PART No.: MT					
DO NOT SCALE DRAWING		CHECK	2015-7-16	HONG	DRAWING No.: 12XT0019					
		APROV.	2015-7-16					SCALE:NA	SHT. 1 OF 1	REV. 00
		ALL DIMENSIONS IN mm UNLESS OTHERWISE STATED								

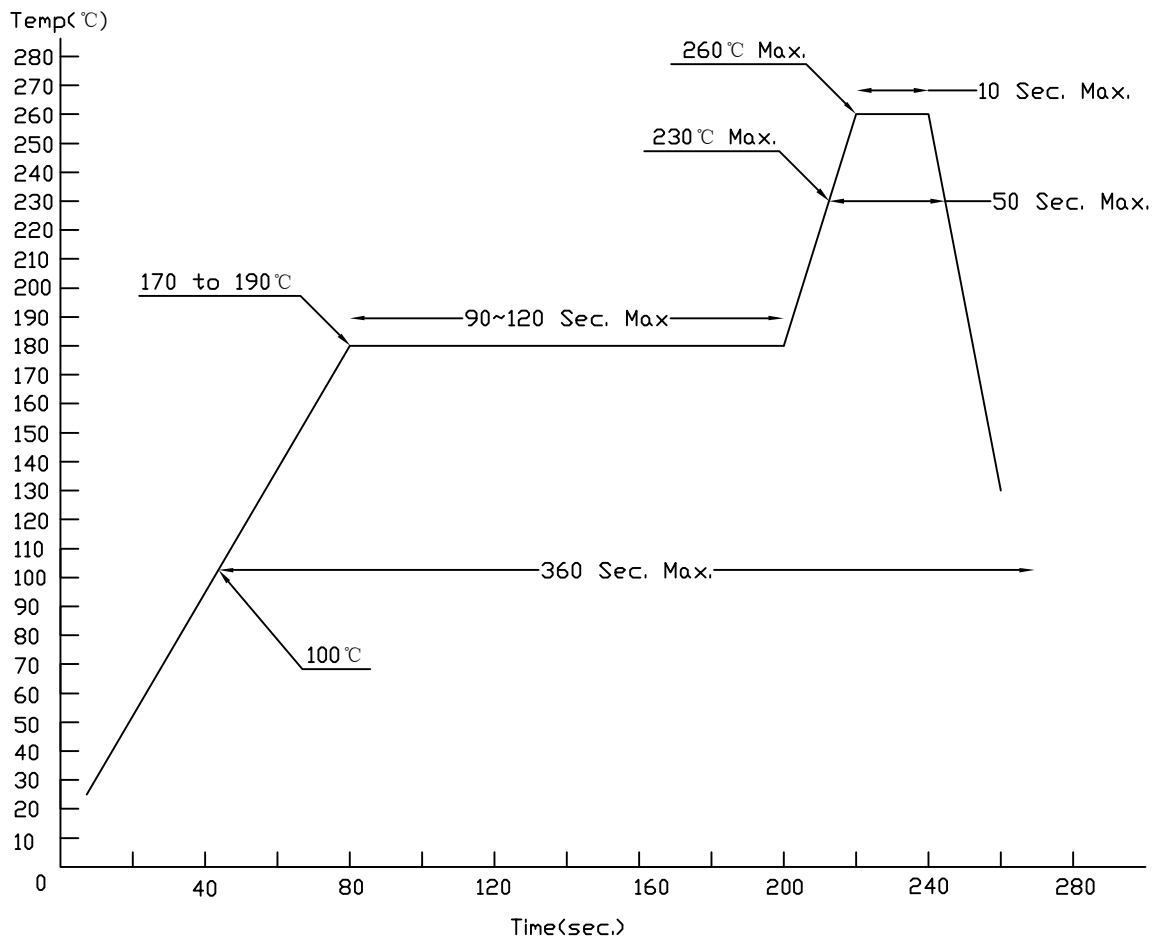

## Note:

1. Lead Free or RoHS Compliance
2. Ramp up rate (from 217°C to 260°C): 3°C/Sec. Max.
3. Ramp down rate: 4°C/Sec. Max.
4. Recommended reflow times: 2 times Max.
5. Effective products:
  - AT cut SMD type crystals including 49US SMD Crystal, Ceramic SMD Crystal, Glass Frit Crystal etc.
  - AT cut SMD type oscillators including crystal oscillator, VCXO, TCXO, OCXO etc.
6. High temperature type SMD tuning fork crystal

ITEM	QTY.	DESCRIPTION	MAT'L	HDN.	SURFACE	MAT'L SIZE	REMARK
GENERAL TOLERANCE:			DATE	NAME		TITLE: Product Reflow Profile	
X=±0.5	X°=±0.5°	DRAWN	11-06-2013	TAN		PART No.: Refer to DWG Description	
.X=±0.1	.X°=±0.1°	CHECK	11-06-2013	PANG		DRAWING No.: 13000002	
.XX=±0.05	.XX°=±0.05°	APROV.	11-06-2013			SCALE: NA	
PROPRIETARY NOTICE : THIS DRAWINGS AND SPECIFICATIONS ARE THE PROPERTY OF HKC.					SHT. 1 OF 1		REV.02
DO NOT SCALE DRAWING		ALL DIMENSIONS IN mm UNLESS OTHERWISE STATED					

FEED DIRECTION

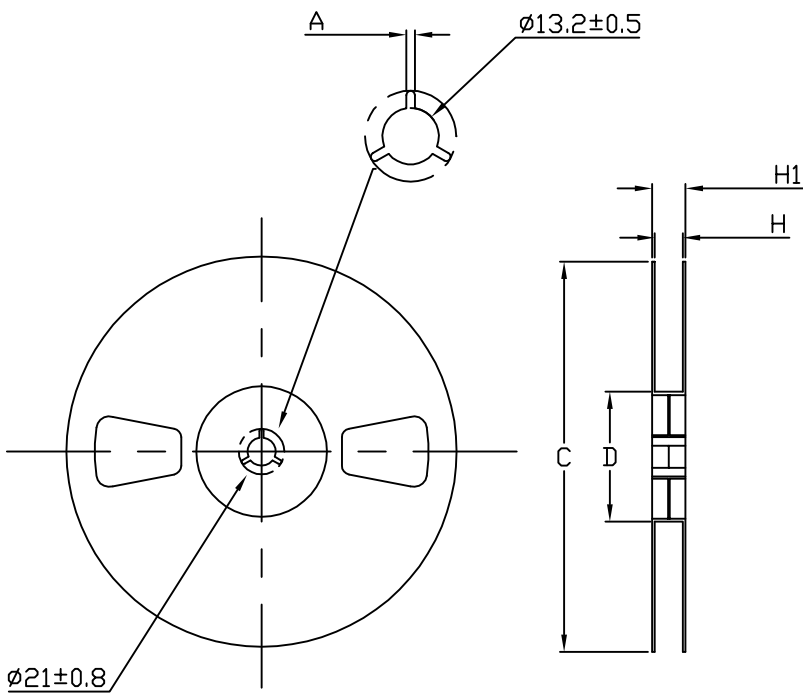
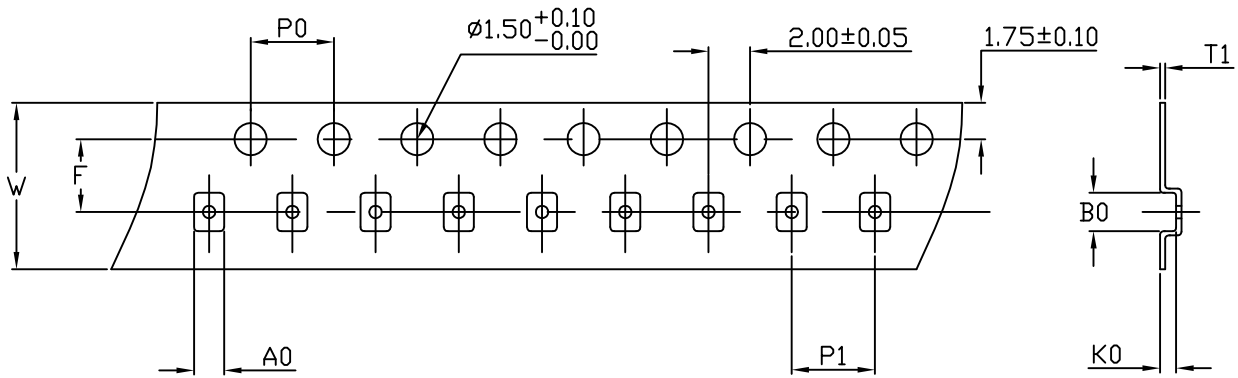

		1.6x1.0 - MT CERAMIC SMD TUNING FORK CRYSTAL
T A P E	W	8.0±0.2
	P1	4.0±0.1
	A0	1.25±0.10
	B0	1.85±0.10
	K0	0.7±0.1
	P0	4.0±0.1
	10P0	40.0±0.2
	F	3.50±0.05
T1	0.25±0.05	
R E E L	C	∅178 <sup>+0</sup> <sub>-3</sub>
	A	2.5 <sup>+0.5</sup> <sub>-0</sub>
	D	∅60.2±0.5
	H	9.0±0.3
	H1	11.4±1.0
STANDARD PACKING QTY/REEL		5000PCS
MAXIMUM PACKING QTY/REEL		5000PCS

GENERAL TOLERANCE:  
 X=±0.5 X°=±0.5°  
 .X=±0.1 .X°=±0.1°  
 .XX=±0.05 .XX°=±0.05°

	DATE	NAME
DRAWN	2015-10-15	TAN
CHECK	2015-10-15	PANG
APROV.	2015-10-15	

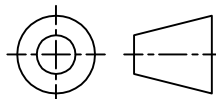

TITLE : MT-1.6X1.0 CERAMIC SMD TUNING FORK CRYSTAL TAPE & REEL

PROPRIETARY NOTICE : THIS DRAWINGS AND SPECIFICATIONS ARE THE PROPERTY OF KOLINKER

**HONG KONG X'TALS LTD.**

PART No.: NIL.

DRAWING No.: 12XP0017

DO NOT SCALE DRAWING

ALL DIMENSIONS IN mm UNLESS OTHERWISE STATED

SCALE: NA

SHT. 1 OF 1

REV. 01