

## DUAL FULL-BRIDGE DRIVER

- OPERATING SUPPLY VOLTAGE UP TO 46 V
- TOTAL DC CURRENT UP TO 4 A
- LOW SATURATION VOLTAGE
- OVERTEMPERATURE PROTECTION
- LOGICAL "0" INPUT VOLTAGE UP TO 1.5 V (HIGH NOISE IMMUNITY)

### DESCRIPTION

The L298 is an integrated monolithic circuit in a 15-lead Multiwatt and PowerSO20 packages. It is a high voltage, high current dual full-bridge driver designed to accept standard TTL logic levels and drive inductive loads such as relays, solenoids, DC and stepping motors. Two enable inputs are provided to enable or disable the device independently of the input signals. The emitters of the lower transistors of each bridge are connected together and the corresponding external terminal can be used for the con-

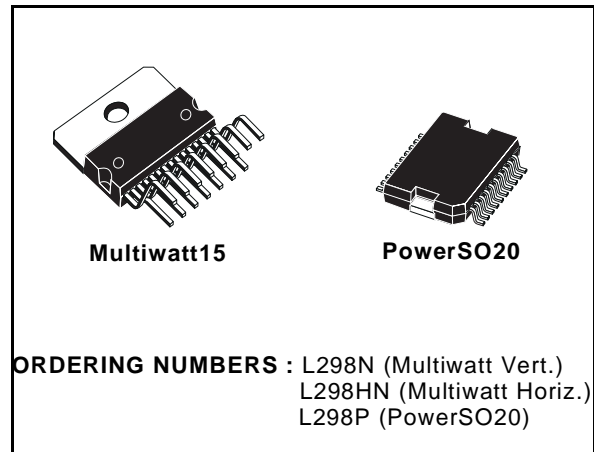

nection of an external sensing resistor. An additional supply input is provided so that the logic works at a lower voltage.

### BLOCK DIAGRAM

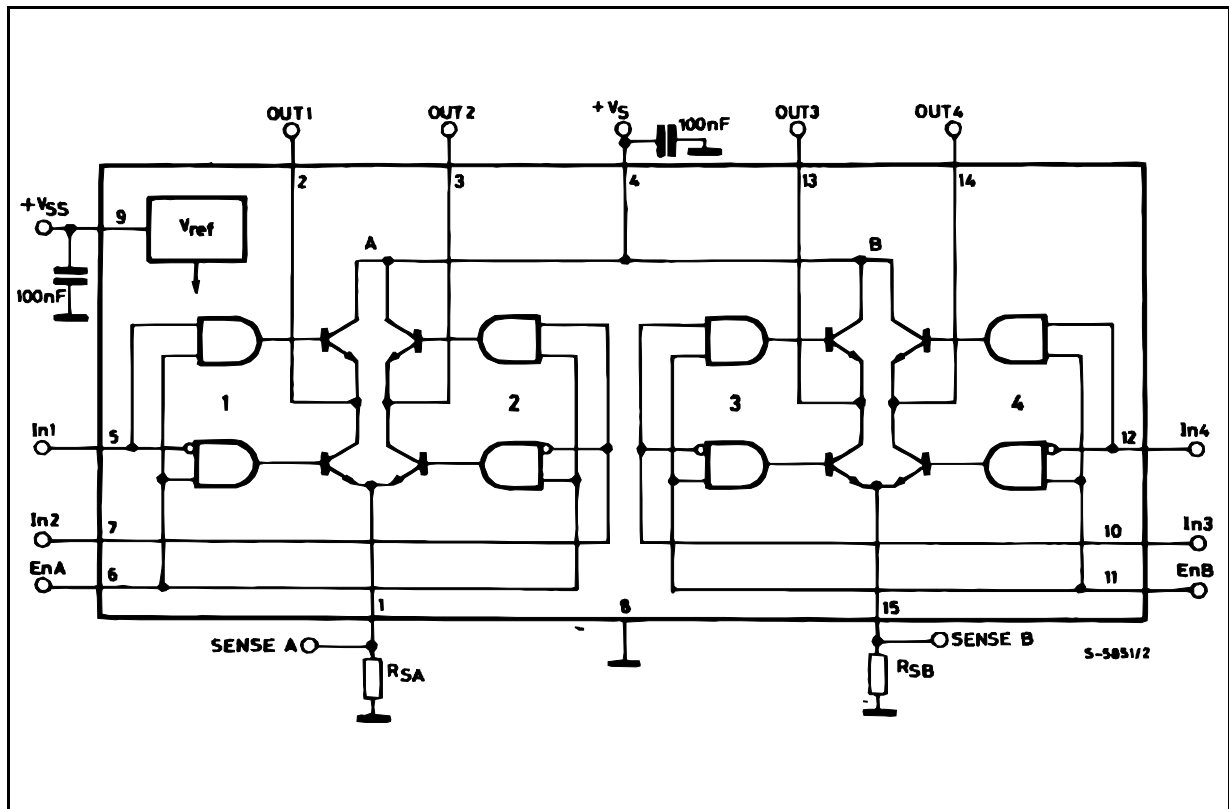

**ABSOLUTE MAXIMUM RATINGS**

Symbol	Parameter	Value	Unit
$V_S$	Power Supply	50	V
$V_{SS}$	Logic Supply Voltage	7	V
$V_I, V_{en}$	Input and Enable Voltage	-0.3 to 7	V
$I_O$	Peak Output Current (each Channel)		
	- Non Repetitive ( $t = 100\mu s$ )	3	A
	- Repetitive (80% on -20% off; $t_{on} = 10ms$ )	2.5	A
	-DC Operation	2	A
$V_{sens}$	Sensing Voltage	-1 to 2.3	V
$P_{tot}$	Total Power Dissipation ( $T_{case} = 75^\circ C$ )	25	W
$T_{op}$	Junction Operating Temperature	-25 to 130	$^\circ C$
$T_{stg}, T_j$	Storage and Junction Temperature	-40 to 150	$^\circ C$

**PIN CONNECTIONS (top view)**



**THERMAL DATA**

Symbol	Parameter		PowerSO20	Multiwatt15	Unit
$R_{th j-case}$	Thermal Resistance Junction-case	Max.	-	3	$^\circ C/W$
$R_{th j-amb}$	Thermal Resistance Junction-ambient	Max.	13 (*)	35	$^\circ C/W$

(\*) Mounted on aluminum substrate



## PIN FUNCTIONS (refer to the block diagram)

MW.15	PowerSO	Name	Function
1;15	2;19	Sense A; Sense B	Between this pin and ground is connected the sense resistor to control the current of the load.
2;3	4;5	Out 1; Out 2	Outputs of the Bridge A; the current that flows through the load connected between these two pins is monitored at pin 1.
4	6	V <sub>s</sub>	Supply Voltage for the Power Output Stages. A non-inductive 100nF capacitor must be connected between this pin and ground.
5;7	7;9	Input 1; Input 2	TTL Compatible Inputs of the Bridge A.
6;11	8;14	Enable A; Enable B	TTL Compatible Enable Input: the L state disables the bridge A (enable A) and/or the bridge B (enable B).
8	1,10,11,20	GND	Ground.
9	12	V <sub>SS</sub>	Supply Voltage for the Logic Blocks. A100nF capacitor must be connected between this pin and ground.
10; 12	13;15	Input 3; Input 4	TTL Compatible Inputs of the Bridge B.
13; 14	16;17	Out 3; Out 4	Outputs of the Bridge B. The current that flows through the load connected between these two pins is monitored at pin 15.
–	3;18	N.C.	Not Connected

ELECTRICAL CHARACTERISTICS (V<sub>S</sub> = 42V; V<sub>SS</sub> = 5V, T<sub>j</sub> = 25°C; unless otherwise specified)

Symbol	Parameter	Test Conditions	Min.	Typ.	Max.	Unit
V <sub>S</sub>	Supply Voltage (pin 4)	Operative Condition	V <sub>IH</sub> +2.5		46	V
V <sub>SS</sub>	Logic Supply Voltage (pin 9)		4.5	5	7	V
I <sub>S</sub>	Quiescent Supply Current (pin 4)	V <sub>en</sub> = H; I <sub>L</sub> = 0 V <sub>i</sub> = L V <sub>i</sub> = H		13 50	22 70	mA mA
		V <sub>en</sub> = L V <sub>i</sub> = X			4	mA
I <sub>SS</sub>	Quiescent Current from V <sub>SS</sub> (pin 9)	V <sub>en</sub> = H; I <sub>L</sub> = 0 V <sub>i</sub> = L V <sub>i</sub> = H		24 7	36 12	mA mA
		V <sub>en</sub> = L V <sub>i</sub> = X			6	mA
V <sub>iL</sub>	Input Low Voltage (pins 5, 7, 10, 12)		–0.3		1.5	V
V <sub>iH</sub>	Input High Voltage (pins 5, 7, 10, 12)		2.3		V <sub>SS</sub>	V
I <sub>iL</sub>	Low Voltage Input Current (pins 5, 7, 10, 12)	V <sub>i</sub> = L			–10	μA
I <sub>iH</sub>	High Voltage Input Current (pins 5, 7, 10, 12)	V <sub>i</sub> = H ≤ V <sub>SS</sub> – 0.6V		30	100	μA
V <sub>en</sub> = L	Enable Low Voltage (pins 6, 11)		–0.3		1.5	V
V <sub>en</sub> = H	Enable High Voltage (pins 6, 11)		2.3		V <sub>SS</sub>	V
I <sub>en</sub> = L	Low Voltage Enable Current (pins 6, 11)	V <sub>en</sub> = L			–10	μA
I <sub>en</sub> = H	High Voltage Enable Current (pins 6, 11)	V <sub>en</sub> = H ≤ V <sub>SS</sub> – 0.6V		30	100	μA
V <sub>CEsat</sub> (H)	Source Saturation Voltage	I <sub>L</sub> = 1A I <sub>L</sub> = 2A	0.95	1.35 2	1.7 2.7	V V
V <sub>CEsat</sub> (L)	Sink Saturation Voltage	I <sub>L</sub> = 1A (5) I <sub>L</sub> = 2A (5)	0.85	1.2 1.7	1.6 2.3	V V
V <sub>CEsat</sub>	Total Drop	I <sub>L</sub> = 1A (5) I <sub>L</sub> = 2A (5)	1.80		3.2 4.9	V V
V <sub>sens</sub>	Sensing Voltage (pins 1, 15)		–1 (1)		2	V

ELECTRICAL CHARACTERISTICS (continued)

Symbol	Parameter	Test Conditions	Min.	Typ.	Max.	Unit
T <sub>1</sub> (V <sub>i</sub> )	Source Current Turn-off Delay	0.5 V <sub>i</sub> to 0.9 I <sub>L</sub> (2); (4)		1.5		μs
T <sub>2</sub> (V <sub>i</sub> )	Source Current Fall Time	0.9 I <sub>L</sub> to 0.1 I <sub>L</sub> (2); (4)		0.2		μs
T <sub>3</sub> (V <sub>i</sub> )	Source Current Turn-on Delay	0.5 V <sub>i</sub> to 0.1 I <sub>L</sub> (2); (4)		2		μs
T <sub>4</sub> (V <sub>i</sub> )	Source Current Rise Time	0.1 I <sub>L</sub> to 0.9 I <sub>L</sub> (2); (4)		0.7		μs
T <sub>5</sub> (V <sub>i</sub> )	Sink Current Turn-off Delay	0.5 V <sub>i</sub> to 0.9 I <sub>L</sub> (3); (4)		0.7		μs
T <sub>6</sub> (V <sub>i</sub> )	Sink Current Fall Time	0.9 I <sub>L</sub> to 0.1 I <sub>L</sub> (3); (4)		0.25		μs
T <sub>7</sub> (V <sub>i</sub> )	Sink Current Turn-on Delay	0.5 V <sub>i</sub> to 0.9 I <sub>L</sub> (3); (4)		1.6		μs
T <sub>8</sub> (V <sub>i</sub> )	Sink Current Rise Time	0.1 I <sub>L</sub> to 0.9 I <sub>L</sub> (3); (4)		0.2		μs
f <sub>c</sub> (V <sub>i</sub> )	Commutation Frequency	I <sub>L</sub> = 2A		25	40	KHz
T <sub>1</sub> (V <sub>en</sub> )	Source Current Turn-off Delay	0.5 V <sub>en</sub> to 0.9 I <sub>L</sub> (2); (4)		3		μs
T <sub>2</sub> (V <sub>en</sub> )	Source Current Fall Time	0.9 I <sub>L</sub> to 0.1 I <sub>L</sub> (2); (4)		1		μs
T <sub>3</sub> (V <sub>en</sub> )	Source Current Turn-on Delay	0.5 V <sub>en</sub> to 0.1 I <sub>L</sub> (2); (4)		0.3		μs
T <sub>4</sub> (V <sub>en</sub> )	Source Current Rise Time	0.1 I <sub>L</sub> to 0.9 I <sub>L</sub> (2); (4)		0.4		μs
T <sub>5</sub> (V <sub>en</sub> )	Sink Current Turn-off Delay	0.5 V <sub>en</sub> to 0.9 I <sub>L</sub> (3); (4)		2.2		μs
T <sub>6</sub> (V <sub>en</sub> )	Sink Current Fall Time	0.9 I <sub>L</sub> to 0.1 I <sub>L</sub> (3); (4)		0.35		μs
T <sub>7</sub> (V <sub>en</sub> )	Sink Current Turn-on Delay	0.5 V <sub>en</sub> to 0.9 I <sub>L</sub> (3); (4)		0.25		μs
T <sub>8</sub> (V <sub>en</sub> )	Sink Current Rise Time	0.1 I <sub>L</sub> to 0.9 I <sub>L</sub> (3); (4)		0.1		μs

- 1) Sensing voltage can be -1 V for t ≤ 50 μsec; in steady state V<sub>sens</sub> min ≥ -0.5 V.
- 2) See fig. 2.
- 3) See fig. 4.
- 4) The load must be a pure resistor.

Figure 1 : Typical Saturation Voltage vs. Output Current.



Figure 2 : Switching Times Test Circuits.



Note : For INPUT Switching, set EN = H  
 For ENABLE Switching, set IN = H