

Distributed by:

JAMECO[®]
ELECTRONICS

www.Jameco.com ♦ 1-800-831-4242

The content and copyrights of the attached
material are the property of its owner.

Jameco Part Number 2067911

LF-to-2.5GHz Dual Logarithmic Detector/ Controller for Power, Gain, and VSWR Measurements

General Description

The MAX2016 dual logarithmic detector/controller is a fully integrated system designed for measuring and comparing power, gain/loss, and voltage standing-wave ratio (VSWR) of two incoming RF signals. An internal broadband impedance match on the two differential RF input ports allows for the simultaneous monitoring of signals ranging from low frequency to 2.5GHz.

The MAX2016 uses a pair of logarithmic amplifiers to detect and compare the power levels of two RF input signals. The device internally subtracts one power level from the other to provide a DC output voltage that is proportional to the power difference (gain). The MAX2016 can also measure the return loss/VSWR of an RF signal by monitoring the incident and reflected power levels associated with any given load. A window detector is easily implemented by using the on-chip comparators, OR gate, and 2V reference. This combination of circuitry provides an automatic indication of when the measured gain is outside a programmable range. Alarm monitoring can thus be implemented for detecting high-VSWR states (such as open or shorted loads).

The MAX2016 operates from a single +2.7V to +5.25V* power supply and is specified over the extended -40°C to +85°C temperature range. The MAX2016 is available in a space-saving, 5mm x 5mm, 28-pin thin QFN.

Applications

- Return Loss/VSWR Measurements
- Dual-Channel RF Power Measurements
- Dual-Channel Precision AGC/RF Power Control
- Log Ratio Function for RF Signals
- Remote System Monitoring and Diagnostics
- Cellular Base Station, Microwave Link, Radar, and other Military Applications
- RF/IF Power Amplifier (PA) Linearization

Typical Application Circuit appears at end of data sheet.

Features

- ◆ Complete Gain and VSWR Detector/Controller
- ◆ Dual-Channel RF Power Detector/Controller
- ◆ Low-Frequency to 2.5GHz Frequency Range
- ◆ Exceptional Accuracy Over Temperature
- ◆ High 80dB Dynamic Range
- ◆ 2.7V to 5.25V Supply Voltage Range*
- ◆ Internal 2V Reference
- ◆ Scaling Stable Over Supply and Temperature Variations
- ◆ Controller Mode with Error Output
- ◆ Available in 5mm x 5mm 28-Pin Thin QFN Package

*See Power-Supply Connection section.

Ordering Information

PART	TEMP RANGE	PIN-PACKAGE	PKG CODE
MAX2016ETI	-40°C to +85°C	28 Thin QFN-EP*, bulk	T2855-3
MAX2016ETI-T	-40°C to +85°C	28 Thin QFN-EP*, T/R	T2855-3
MAX2016ETI+D	-40°C to +85°C	28 Thin QFN-EP*, lead free, bulk	T2855-3
MAX2016ETI+TD	-40°C to +85°C	28 Thin QFN-EP*, lead free, T/R	T2855-3

*EP = Exposed pad.

+ = Lead free.

D = Dry pack.

Pin Configuration

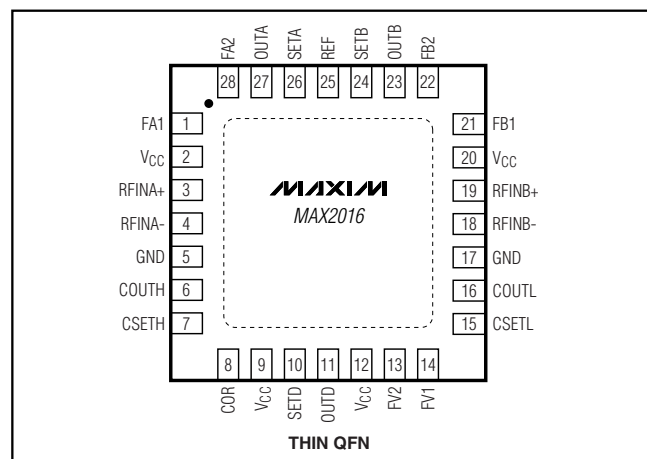

LF-to-2.5GHz Dual Logarithmic Detector/ Controller for Power, Gain, and VSWR Measurements

ABSOLUTE MAXIMUM RATINGS

V _{CC} to GND	-0.3V to +5.25V
Input Power Differential (RFIN ₊ , RFIN ₋)	+23dBm
Input Power Single Ended (RFIN ₊ or RFIN ₋)	+19dBm
All Other Pins to GND	-0.3V to (V _{CC} + 0.3V)
Continuous Power Dissipation (T _A = +70°C) 28-Pin, 5mm x 5mm Thin QFN (derate 35.7mW/°C above +70°C)	2.8W

Operating Temperature Range	-40°C to +85°C
Junction Temperature	+150°C
Storage Temperature Range	-65°C to +150°C
Lead Temperature (soldering, 10s)	+300°C

Stresses beyond those listed under "Absolute Maximum Ratings" may cause permanent damage to the device. These are stress ratings only, and functional operation of the device at these or any other conditions beyond those indicated in the operational sections of the specifications is not implied. Exposure to absolute maximum rating conditions for extended periods may affect device reliability.

DC ELECTRICAL CHARACTERISTICS

(V_{CC} = +2.7V to +3.6V, R₁ = R₂ = R₃ = 0Ω, T_A = -40°C to +85°C, unless otherwise noted. Typical values are at V_{CC} = +3.3V, CSETL = CSETH = V_{CC}, 50Ω RF system, T_A = +25°C, unless otherwise noted.) (Note 1)

PARAMETER	SYMBOL	CONDITIONS	MIN	TYP	MAX	UNITS
POWER SUPPLY						
Supply Voltage	V _S	R ₆ = 0Ω	2.7	3.3	3.6	V
	V _S	R ₆ = 37.4Ω	4.75	5	5.25	
Total Supply Current	I _{CC}			43	55	mA
Supply Current		Measured in each pin 2 and pin 20		16		mA
		Measured in pin 9		2		
		Measured in pin 12		9		
INPUT INTERFACE						
Input Impedance		Differential impedance at RFINA and RFINB		50		Ω
Input Resistance	R	Resistance at SETD		20		kΩ
		Resistance at SETA and SETB		40		
DETECTOR OUTPUT						
Source Current		Measured at OUTA, OUTB, and OUTD		4		mA
Sink Current		Measured at OUTA, OUTB, and OUTD		0.45		mA
Minimum Output Voltage		Measured at OUTA, OUTB, and OUTD		0.5		V
Maximum Output Voltage		Measured at OUTA, OUTB, and OUTD		1.8		V
Difference Output VO _{UTD}		P _{RFINA} = P _{RFINB} = -30dBm		1		V
OUTD Accuracy				±12		mV
COMPARATORS						
Output High Voltage	V _{OH}	R _{LOAD} ≥ 10kΩ		V _{CC} - 10mV		V
Output Low Voltage	V _{OL}	R _{LOAD} ≥ 10kΩ		10		mV
Input Voltage		Measured at CSETL and CSETH		GND to V _{CC}		V
Input Bias Current		CSETL and CSETH		1		nA
REFERENCE						
Output Voltage on Pin 25		R _{LOAD} ≥ 2kΩ		2		V
Load Regulation		Source 2mA		-5		mV

LF-to-2.5GHz Dual Logarithmic Detector/ Controller for Power, Gain, and VSWR Measurements

MAX2016

AC ELECTRICAL CHARACTERISTICS—OUTA AND OUTB

(Typical Application Circuit, $V_{CC} = +2.7V$ to $+3.3V$, $R_1 = R_2 = R_3 = 0\Omega$, $T_A = -40^\circ C$ to $+85^\circ C$, unless otherwise noted. Typical values are at $V_{CC} = 3.3V$, $CSETL = CSETH = V_{CC}$, $T_A = +25^\circ C$, unless otherwise noted.) (Note 1)

PARAMETER	SYMBOL	CONDITIONS		MIN	TYP	MAX	UNITS
RF Input Frequency Range	f_{RF}	AC-coupled input				2.5	GHz
Return Loss	S_{11}	0.1GHz to 3GHz			20		dB
Large-Signal Response Time		PRFIN = no signal to 0dBm, ± 0.5 dB settling accuracy			100		ns
RSSI MODE—0.1GHz							
RF Input Power Range		(Note 2)			-70 to +10		dBm
± 3 dB Dynamic Range		$T_A = -20^\circ C$ to $+85^\circ C$ (Note 3)			80		dB
Range Center					-32		dBm
Temperature Sensitivity		PRFINA = PRFINB = -32dBm	$T_A = +25^\circ C$ to $+85^\circ C$		+0.0083		dB/ $^\circ C$
			$T_A = +25^\circ C$ to $-20^\circ C$		-0.0083		
Slope		(Note 4)			19		mV/dB
Typical Slope Variation		$T_A = -20^\circ C$ to $+85^\circ C$			-4		$\mu V/^\circ C$
Intercept		(Note 5)			-100		dBm
Typical Intercept Variation		$T_A = -20^\circ C$ to $+85^\circ C$			0.03		dBm/ $^\circ C$
RSSI MODE—0.9GHz							
RF Input Power Range		(Note 2)			-70 to +10		dBm
± 3 dB Dynamic Range		$T_A = -20^\circ C$ to $+85^\circ C$ (Note 3)			80		dB
Range Center					-30		dBm
Temperature Sensitivity		PRFINA = PRFINB = -30dBm	$T_A = +25^\circ C$ to $+85^\circ C$		+0.0083		dB/ $^\circ C$
			$T_A = +25^\circ C$ to $-20^\circ C$		-0.0083		
Slope		(Note 4)			18.1		mV/dB
Typical Slope Variation		$T_A = -20^\circ C$ to $+85^\circ C$			-4		$\mu V/^\circ C$
Intercept		(Note 5)			-97		dBm
Typical Intercept Variation		$T_A = -20^\circ C$ to $+85^\circ C$			0.02		dBm/ $^\circ C$
RSSI MODE—1.9GHz							
RF Input Power Range		(Note 2)			-55 to +12		dBm
± 3 dB Dynamic Range		$T_A = -20^\circ C$ to $+85^\circ C$ (Note 3)			67		dB
Range Center					-27		dBm
Temperature Sensitivity		PRFINA = PRFINB = -27dBm	$T_A = +25^\circ C$ to $+85^\circ C$		+0.0125		dB/ $^\circ C$
			$T_A = +25^\circ C$ to $-20^\circ C$		-0.0125		
Slope		(Note 4)			18		mV/dB
Typical Slope Variation		$T_A = -20^\circ C$ to $+85^\circ C$			-4.8		$\mu V/^\circ C$
Intercept		(Note 5)			-88		dBm
Typical Intercept Variation		$T_A = -20^\circ C$ to $+85^\circ C$			0.03		dBm/ $^\circ C$

LF-to-2.5GHz Dual Logarithmic Detector/ Controller for Power, Gain, and VSWR Measurements

AC ELECTRICAL CHARACTERISTICS—OUTA AND OUTB (continued)

(Typical Application Circuit, $V_{CC} = +2.7V$ to $+3.3V$, $R_1 = R_2 = R_3 = 0\Omega$, $T_A = -40^\circ C$ to $+85^\circ C$, unless otherwise noted. Typical values are at $V_{CC} = 3.3V$, $CSETL = CSETH = V_{CC}$, $T_A = +25^\circ C$, unless otherwise noted.) (Note 1)

PARAMETER	SYMBOL	CONDITIONS	MIN	TYP	MAX	UNITS
RSSI MODE—2.17GHz						
RF Input Power Range		(Note 2)		-52 to +12		dBm
± 3 dB Dynamic Range		$T_A = -20^\circ C$ to $+85^\circ C$ (Note 3)		64		dB
Range Center				-25		dBm
Temperature Sensitivity		PRFINA = PRFINB = -25dBm		+0.0135 -0.0135		dB/ $^\circ C$
Slope		(Note 4)		17.8		mV/dB
Typical Slope Variation		$T_A = -20^\circ C$ to $+85^\circ C$		-8		$\mu V/^\circ C$
Intercept		(Note 5)		-81		dBm
Typical Intercept Variation		$T_A = -20^\circ C$ to $+85^\circ C$		0.03		dBm/ $^\circ C$
RSSI MODE—2.5GHz						
RF Input Power Range		(Note 2)		-45 to +7		dBm
± 3 dB Dynamic Range		$T_A = -20^\circ C$ to $+85^\circ C$ (Note 3)		52		dB
Range Center				-23		dBm
Temperature Sensitivity		PRFINA = PRFINB = -23dBm		+0.0167 -0.0167		dB/ $^\circ C$
Slope		(Note 4)		17.8		mV/dB
Typical Slope Variation		$T_A = -20^\circ C$ to $+85^\circ C$		-8		$\mu V/^\circ C$
Intercept		(Note 5)		-80		dBm
Typical Intercept Variation		$T_A = -20^\circ C$ to $+85^\circ C$		0.03		dBm/ $^\circ C$

AC ELECTRICAL CHARACTERISTICS—OUTD

(Typical Application Circuit, $V_{CC} = +2.7V$ to $+3.3V$, $R_1 = R_2 = R_3 = 0\Omega$, $T_A = -40^\circ C$ to $+85^\circ C$, unless otherwise noted. Typical values are at $V_{CC} = 3.3V$, $CSETL = CSETH = V_{CC}$, $T_A = +25^\circ C$, unless otherwise noted.) (Note 1)

PARAMETER	SYMBOL	CONDITIONS	MIN	TYP	MAX	UNITS
OUTD Center Point		PRFINA = PRFINB		1		V
Small-Signal Envelope Bandwidth		No external capacitor on pins FV1 and FV2		22		MHz
Small-Signal Settling Time		Any 8dB change on the inputs, no external capacitor on FV1 and FV2, settling accuracy is ± 0.5 dB		150		ns
Large-Signal Settling Time		Any 30dB change on the inputs, no external capacitor on pins FV1 and FV2, settling accuracy is ± 0.5 dB		300		ns
Small-Signal Rise and Fall Time		Any 8dB step, no external capacitor on pins FV1 and FV2		15		ns

LF-to-2.5GHz Dual Logarithmic Detector/ Controller for Power, Gain, and VSWR Measurements

AC ELECTRICAL CHARACTERISTICS—OUTD (continued)

(Typical Application Circuit, $V_{CC} = +2.7V$ to $+3.3V$, $R_1 = R_2 = R_3 = 0\Omega$, $T_A = -40^\circ C$ to $+85^\circ C$, unless otherwise noted. Typical values are at $V_{CC} = 3.3V$, $CSETL = CSETH = V_{CC}$, $T_A = +25^\circ C$, unless otherwise noted.) (Note 1)

PARAMETER	SYMBOL	CONDITIONS		MIN	TYP	MAX	UNITS
Large-Signal Rise and Fall Time		Any 30dB step, no external capacitor on pins FV1 and FV2			35		ns
±1dB Dynamic Range		0.1GHz	$P_{RFINB} = -32dBm$		80		dB
		0.9GHz	$P_{RFINB} = -30dBm$		75		
		1.9GHz	$P_{RFINB} = -27dBm$		60		
		2.17GHz	$P_{RFINB} = -25dBm$		55		
		2.5GHz	$P_{RFINB} = -23dBm$		50		
Slope		$f_{RF} = 0.1GHz$ to $2.5GHz$			25		mV/dB
OUTD Voltage Deviation		$P_{RFINA} = P_{RFINB} = -30dBm$, $T_A = -20^\circ C$ to $+85^\circ C$			±0.25		dB
±1dB Dynamic Range over Temperature Relative to Best-Fit Curve at $+25^\circ C$		PRFINA is swept ; $T_A = -20^\circ C$ to $+85^\circ C$	0.1GHz, $P_{RFINB} = -32dBm$		80		dB
			0.9GHz, $P_{RFINB} = -30dBm$		70		
			1.9GHz, $P_{RFINB} = -27dBm$		55		
			2.17GHz, $P_{RFINB} = -25dBm$		50		
			2.5GHz, $P_{RFINB} = -23dBm$		45		
Gain Measurement Balance		$P_{RFINB} = P_{RFINB} = -50dBm$ to $-5dBm$, $f_{RF} = 1.9GHz$			0.2		dB
Channel Isolation		0.9GHz			90		dB
		1.9GHz			65		
		2.5GHz			55		

Note 1: The MAX2016 is tested at $T_A = +25^\circ C$ and is guaranteed by design for $T_A = -40^\circ C$ to $+85^\circ C$.

Note 2: Typical minimum and maximum range of the detector at the stated frequency.

Note 3: Dynamic range refers to the range over which the error remains within the ±3dB range.

Note 4: The slope is the variation of the output voltage per change in input power. It is calculated by fitting a root-mean-square straight line to the data indicated by the RF input power range.

Note 5: The intercept is an extrapolated value that corresponds to the output power for which the output voltage is zero. It is calculated by fitting a root-mean-square straight line to the data.

LF-to-2.5GHz Dual Logarithmic Detector/ Controller for Power, Gain, and VSWR Measurements

Typical Operating Characteristics

(MAX2016 EV kit, $V_{CC} = 3.3V$, $R_1 = R_2 = R_3 = 0\Omega$, $CSETL = CSETH = V_{CC}$, $T_A = +25^\circ C$, unless otherwise noted.)

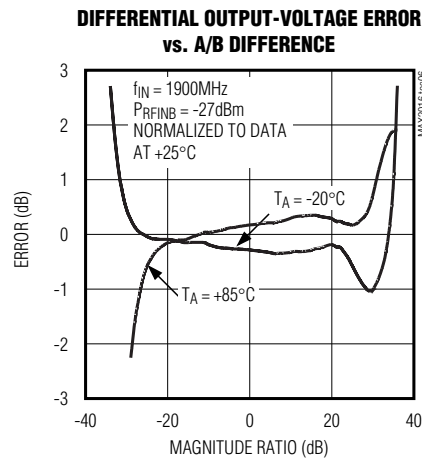
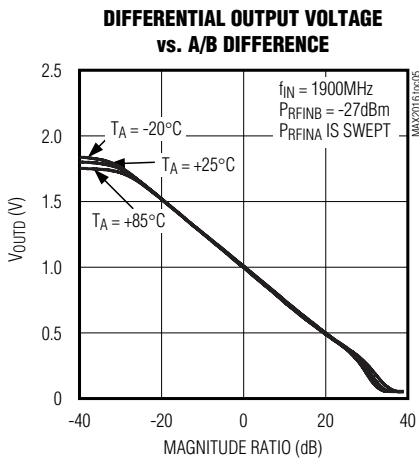
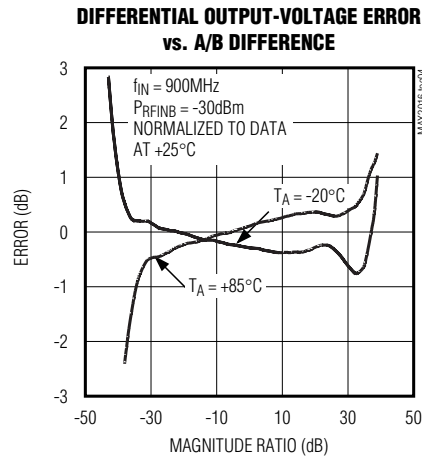
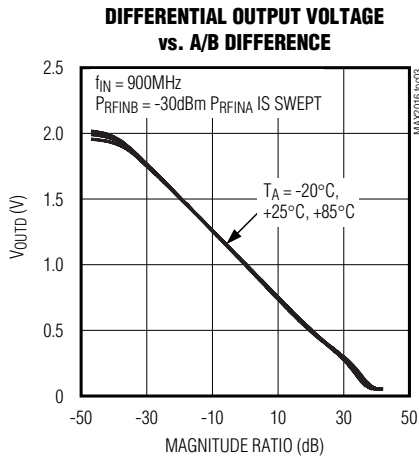
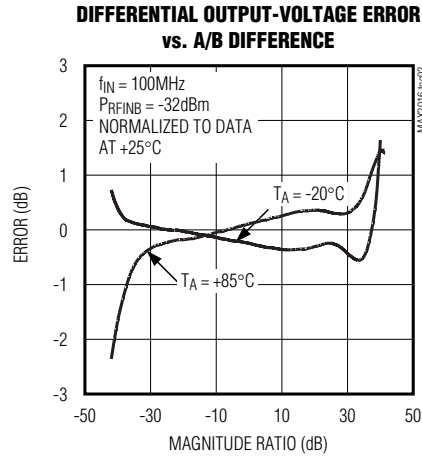
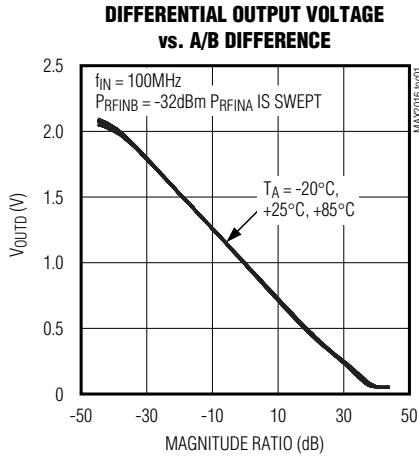

LF-to-2.5GHz Dual Logarithmic Detector/ Controller for Power, Gain, and VSWR Measurements

MAX2016

Typical Operating Characteristics (continued)

(MAX2016 EV kit, $V_{CC} = 3.3V$, $R_1 = R_2 = R_3 = 0\Omega$, $C_{SETL} = C_{SETH} = V_{CC}$, $T_A = +25^\circ C$, unless otherwise noted.)

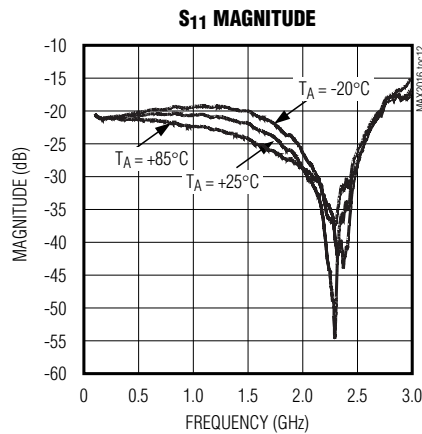
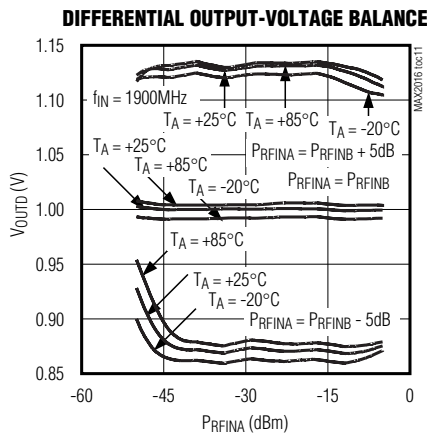
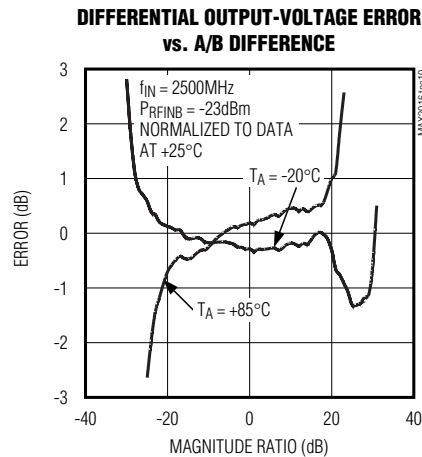
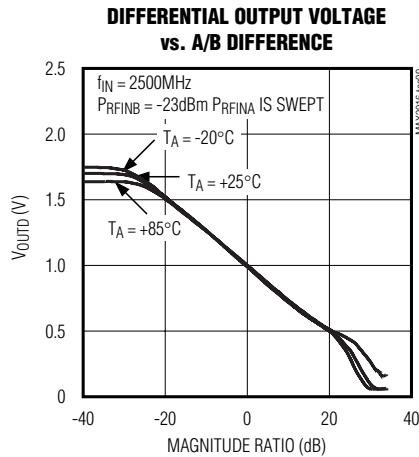
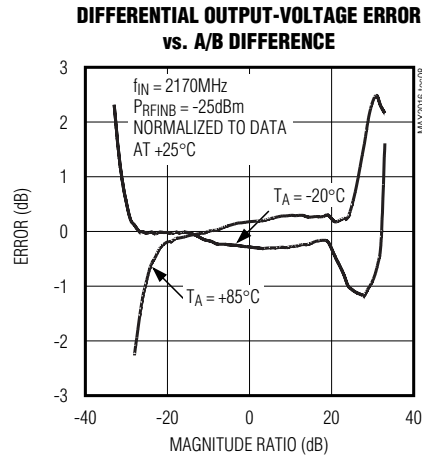
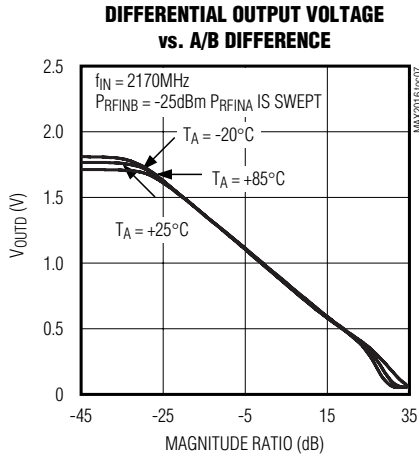

LF-to-2.5GHz Dual Logarithmic Detector/ Controller for Power, Gain, and VSWR Measurements

Typical Operating Characteristics (continued)

(MAX2016 EV kit, $V_{CC} = 3.3V$, $R_1 = R_2 = R_3 = 0\Omega$, $CSETL = CSETH = V_{CC}$, $T_A = +25^\circ C$, unless otherwise noted.)

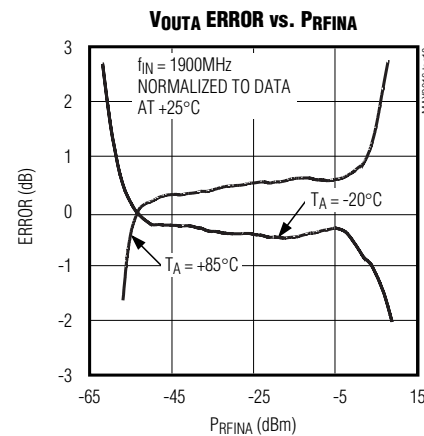
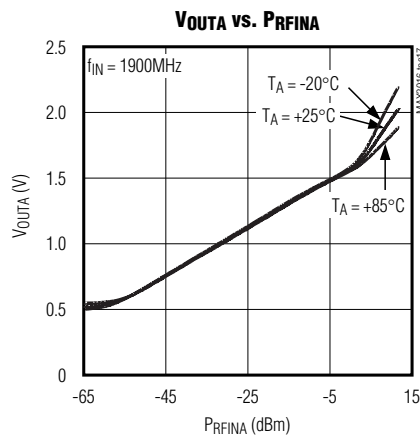
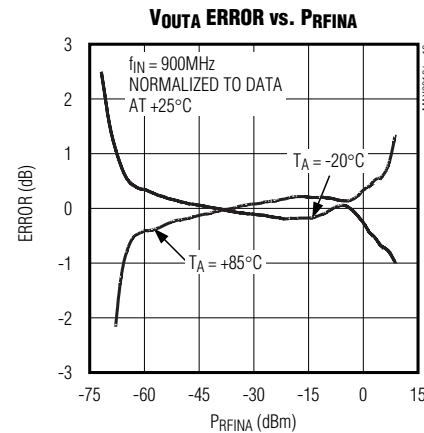
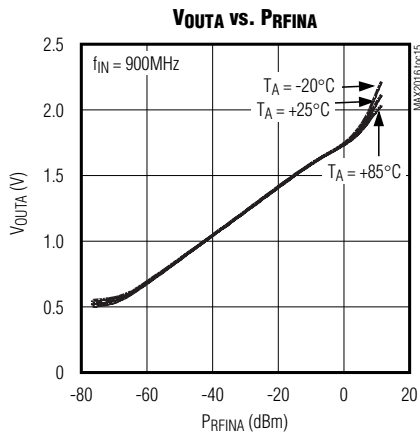
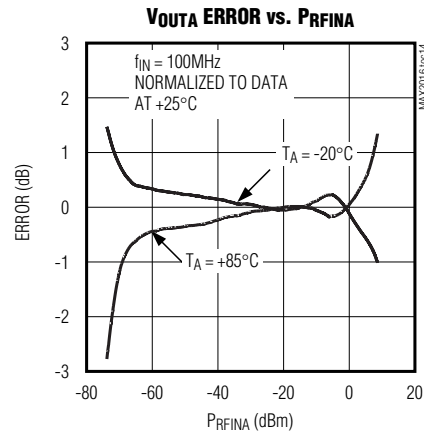
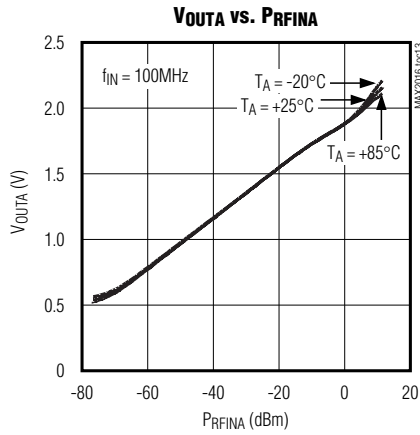

LF-to-2.5GHz Dual Logarithmic Detector/ Controller for Power, Gain, and VSWR Measurements

Typical Operating Characteristics (continued)

(MAX2016 EV kit, $V_{CC} = 3.3V$, $R_1 = R_2 = R_3 = 0\Omega$, $CSETL = CSETH = V_{CC}$, $T_A = +25^\circ C$, unless otherwise noted.)

MAX2016

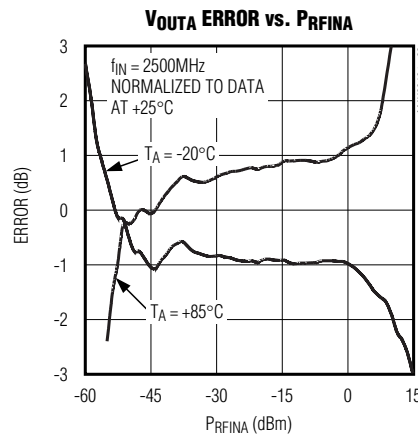
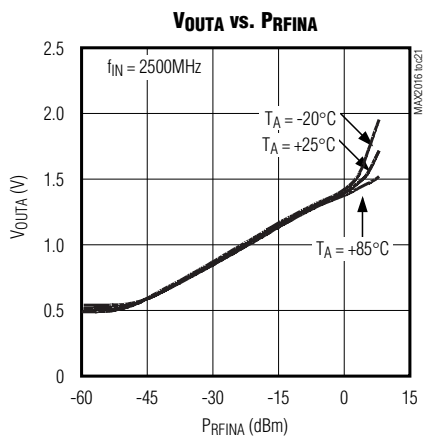
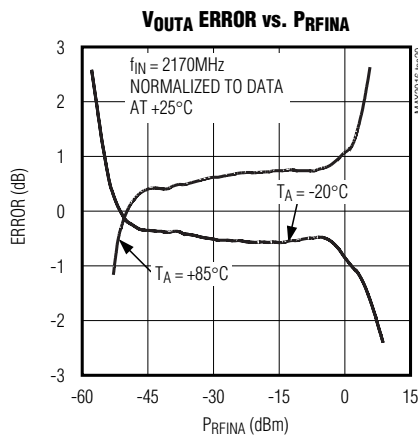
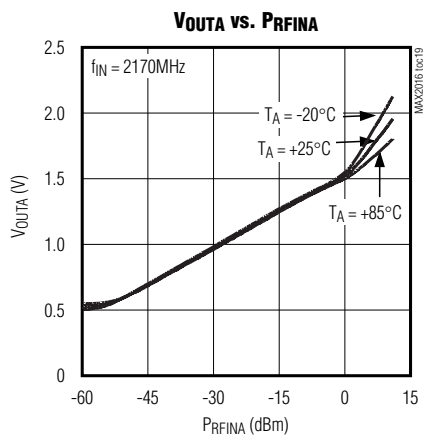

LF-to-2.5GHz Dual Logarithmic Detector/ Controller for Power, Gain, and VSWR Measurements

Pin Description

PIN	NAME	FUNCTION
1, 28	FA1, FA2	External Capacitor Input. Connecting a capacitor between FA1 and FA2 sets the highpass cutoff frequency corner for detector A (see the <i>Input Highpass Filter</i> section).
2, 9, 12, 20	VCC	Supply Voltage. Bypass with capacitors as specified in the <i>Typical Application Circuit</i> . Place capacitors as close to each VCC as possible (see the <i>Power-Supply Connections</i> section).
3, 4	RFINA+, RFINA-	Differential RF Inputs for Detector A. Requires external DC-blocking capacitors.
5, 17	GND	Ground. Connect to the printed circuit (PC) board ground plane.
6	COUTH	High-Comparator Output
7	CSETH	Threshold Input on High Comparator
8	COR	Comparator OR Logic Output. Output of COUTH ORed with COUTL.
10	SETD	Set-Point Input for Gain Detector
11	OUTD	DC Output Voltage Representing $PR_{FINA} - PR_{FINB}$. This output provides a DC voltage proportional to the difference of the input RF powers on RFINA and RFINB.
13, 14	FV2, FV1	Video-Filter Capacitor Inputs for OUTD
15	CSETL	Threshold Set Input on Low Comparator
16	COUTL	Low-Comparator Output
18, 19	RFINB-, RFINB+	Differential RF Inputs for Detector B. Requires external DC-blocking capacitors.
21, 22	FB1, FB2	External Capacitor Input. Connecting a capacitor between FB1 and FB2 sets the highpass cutoff frequency corner for detector B (see the <i>Input Highpass Filter</i> section).
23	OUTB	Detector B Output. This output provides a voltage proportional to the log of the input power on differential inputs RFINB+ and RFINB- (RFINB).
24	SETB	Set-Point Input for Detector B
25	REF	2V Reference Output
26	SETA	Set-Point Input for Detector A
27	OUTA	Detector A Output. This output provides a voltage proportional to the log of the input power on differential inputs RFINA+ and RFINA- (RFINA).
EP	GND	Exposed Paddle. EP must connect to the PC board ground plane.

Detailed Description

The MAX2016 dual logarithmic amplifier is designed for a multitude of applications including dual-channel RF power measurements, AGC control, gain/loss detection, and VSWR monitoring. This device measures RF signals ranging from low frequency to 2.5GHz, and operates from a single 2.7V to 5.25V (using series resistor, R6) power supply. As with its single-channel counterpart (MAX2015), the MAX2016 provides unparalleled performance with a high 80dB dynamic range at 100MHz and exceptional accuracy over the extended temperature and supply voltage ranges.

The MAX2016 uses a pair of logarithmic amplifiers to detect and compare the power levels of two RF input signals. The device subtracts one power level from the other to provide a DC output voltage that is proportional

to the power difference (gain). The MAX2016 can also measure the return loss/VSWR of an RF signal by monitoring the incident and reflected power levels associated with any given load.

A window detector is easily implemented by using the on-chip comparators, OR gate, and 2V reference. This combination of circuitry provides an automatic indication of when the measured gain is outside a programmable range. Alarm monitoring can thus be implemented for detecting high-VSWR states (such as open or shorted loads).

RF Inputs (RFINA and RFINB)

The MAX2016 has two differential RF inputs. The input to detector A (RFINA) uses the two input ports RFINA+ and RFINA-, and the input to detector B (RFINB) uses the two input ports RFINB+ and RFINB-.

LF-to-2.5GHz Dual Logarithmic Detector/ Controller for Power, Gain, and VSWR Measurements

Table 1. Component Values Used in the Typical Application Circuit

DESIGNATION	VALUE	DESCRIPTION
C1, C2, C8, C9	680pF	Microwave capacitors (0402)
C3, C6, C10, C13	33pF	Microwave capacitors (0402)
C4, C7, C11, C14	0.1μF	Microwave capacitors (0603)
C5, C12, C15	Not used	Capacitors are optional for frequency compensation
C18	10μF	Tantalum capacitor (C case)
R1, R2, R3	0Ω	Resistors (0402)
R6	0Ω	Resistor (1206) for V _S = 2.7V to 3.6V
	37.4Ω	±1% resistor (1206) for V _S = 4.75V to 5.25V

The differential RF inputs allow for the measurement of broadband signals ranging from low frequency to 2.5GHz. For single-ended signals, RFINA- and RFINB- are AC-coupled to ground. The RF inputs are internally biased and need to be AC-coupled. Using 680pF capacitors, as shown in the *Typical Application Circuit*, results in a 10MHz highpass corner frequency. An internal 50Ω resistor between RFINA+ and RFINA- (as well as RFINB+ and RFINB-) produces a good low-frequency to 3.0GHz match.

SETA, SETB, and SETD Inputs

The SET_ inputs are used for loop control when the device is in controller mode. Likewise, these same SET_ inputs are used to set the slope of the output signal (mV/dB) when the MAX2016 is in detector mode. The center node of the internal resistor-divider is fed to the negative input of the power detector's internal output op amp.

Reference

The MAX2016 has an on-chip 2V voltage reference. The internal reference output is connected to REF. The output can be used as a reference voltage source for the comparators or other components and can source up to 2mA.

OUTA and OUTB

Each OUT_ is a DC voltage proportional to the RF input power level. The change of OUT_ with respect to the power input is approximately 18mV/dB (R₁ = R₂ = 0Ω). The input power level can be determined by the following equation:

$$P_{RFIN_} = \frac{V_{OUT_}}{SLOPE} + P_{INT}$$

where P_{INT} is the extrapolated intercept point of where the output voltage intersects the horizontal axis.

OUTD

OUTD is a DC voltage proportional to the difference of the input RF power levels. The change of the OUTD with respect to the power difference is 25mV/dB (R₃ = 0Ω). The difference of the input power levels (gain) can be determined by the following equation:

$$P_{RFINA} - P_{RFINB} = \frac{(V_{OUTD} - V_{CENTER})}{SLOPE}$$

where V_{CENTER} is the output voltage, typically 1V, when P_{RFINA} = P_{RFINB}.

Applications Information

Monitoring VSWR and Return Loss

The MAX2016 can be used to measure the VSWR of an RF signal, which is useful for detecting the presence or absence of a properly loaded termination, such as an antenna (see Figure 1). The transmitted wave from the power amplifier is coupled to RFINA and to the antenna. The reflected wave from the antenna is connected to RFINB through a circulator. When the antenna is missing or damaged, a mismatch in the nominal load impedance results, leading to an increase in reflected power and subsequent change in the transmission line's VSWR. This increase in reflected power is manifested by a reduction in the voltage at OUTD. An alarm condition can be set by using the low comparator output (COUTL) as shown in Figure 1. The comparator automatically senses the change in VSWR, yielding a logic 0 as it compares OUTD to a low DC voltage at CSETL. CSETL, in turn, is set by using the internal reference voltage and an external resistor-divider network.

Figure 1 illustrates a simple level detector. For window-detector implementation, see the *Comparator/Window Detector* section.

LF-to-2.5GHz Dual Logarithmic Detector/ Controller for Power, Gain, and VSWR Measurements

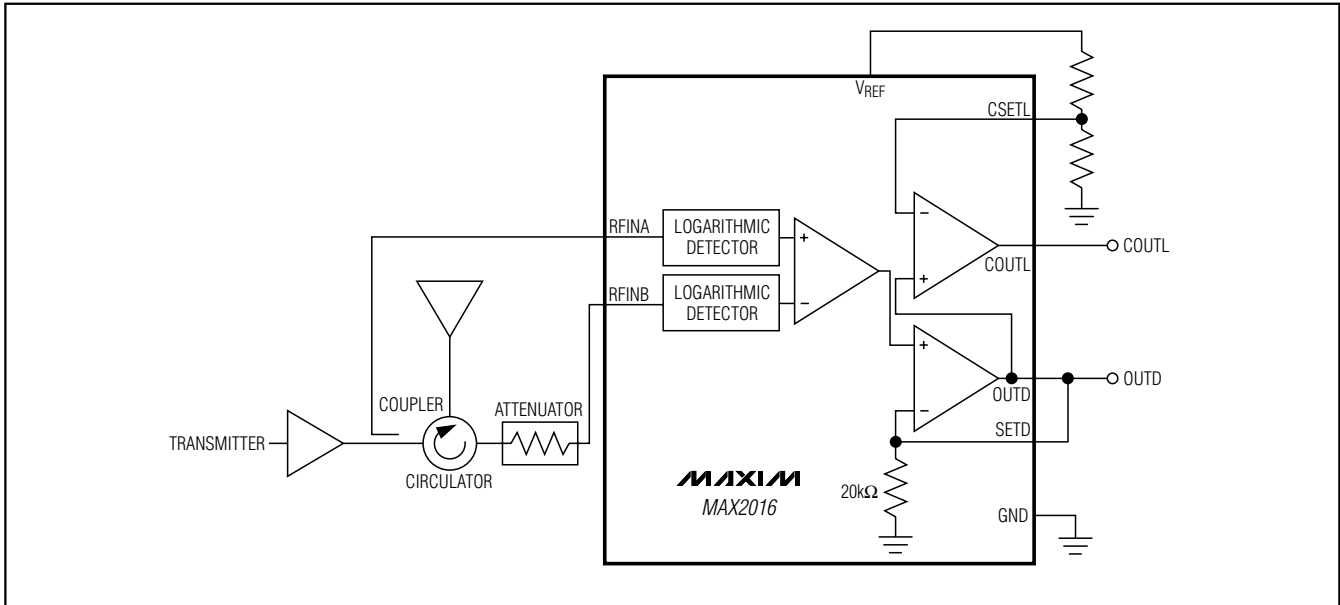

Figure 1. VSWR Monitoring Configuration

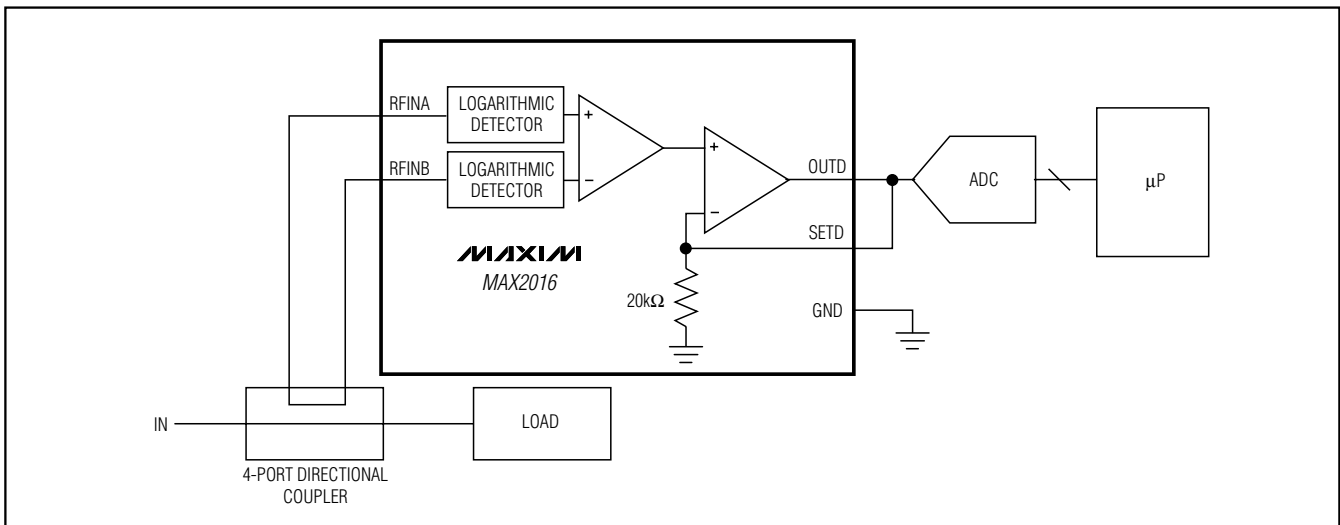

Figure 2. Measuring Return Loss and VSWR of a Given Load

Measuring VSWR and Return Loss

In Figure 2, the two logarithmic amplifiers measure the incident and the reflected power levels to produce two proportional output voltages at OUTA and OUTB. Since OUTD is a DC voltage proportional to the difference of OUTA and OUTB, return loss (RL) and VSWR can be easily calculated within a microprocessor using the following relationships:

$$RL = P_{RFINA} - P_{RFINB} = \frac{(V_{OUTD} - V_{CENTER})}{SLOPE}$$

where return loss (RL) is expressed in decibels, V_{CENTER} is the output voltage (typically 1V) when $P_{RFINA} = P_{RFINB}$, and SLOPE is typically equal to 25mV/dB (for $R_3 = 0\Omega$).

LF-to-2.5GHz Dual Logarithmic Detector/ Controller for Power, Gain, and VSWR Measurements

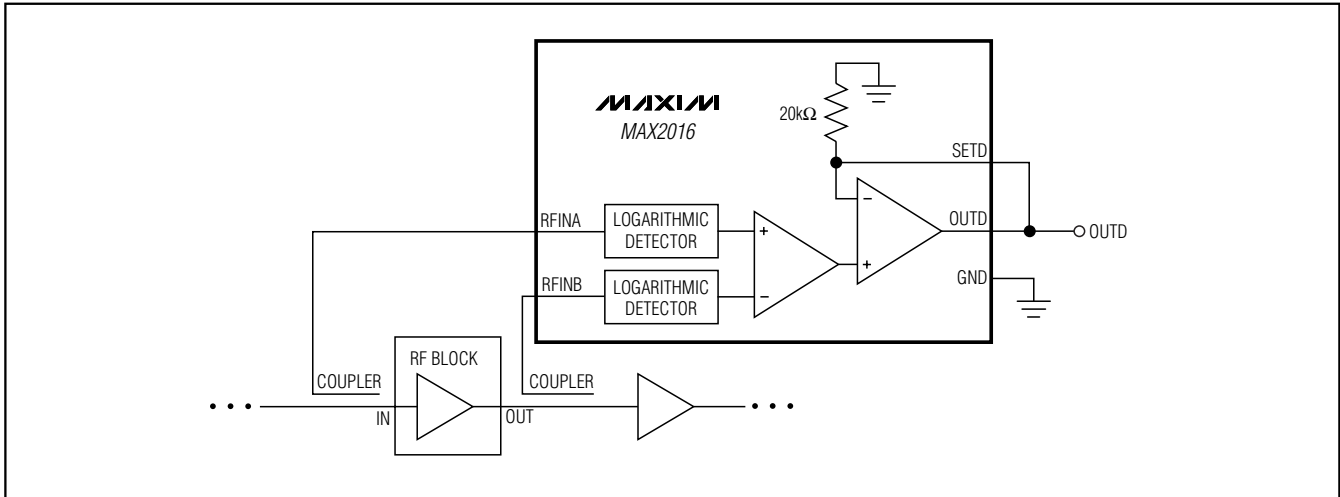

Figure 3. Gain Measurement Configuration

VSWR can similarly be calculated through the following relationship:

$$VSWR = \frac{1 + 10^{-\left(\frac{RL}{20}\right)}}{1 - 10^{-\left(\frac{RL}{20}\right)}}$$

Measuring Gain

The MAX2016 can be used to measure the gain of an RF block (or combination of blocks) through the implementation outlined in Figure 3. As shown, a coupled signal from the input of the block is fed into RFINA, while the coupled output is connected to RFINB. The DC output voltage at OUTD is proportional to the power difference (i.e., gain).

The gain of a complete receiver or transmitter lineup can likewise be measured since the MAX2016 accepts RF signals that range from low frequency to 2.5GHz; see Figure 4. The MAX2016 accurately measures the gain, regardless of the different frequencies present within superheterodyne architectures.

Measuring Power (RSSI Detector Mode)

In detector mode, the MAX2016 acts like a receive-signal-strength indicator (RSSI), which provides an output voltage proportional to the input power. This is accomplished by providing a feedback path from OUTA (OUTB) to SETA (SETB) ($R1/R2 = 0\Omega$; see Figure 5).

By connecting SET_ directly to OUT_, the op-amp gain is set to $2V/V$ due to two internal $20k\Omega$ feedback resis-

tors. This provides a detector slope of approximately 18mV/dB with a 0.5V to 1.8V output range.

Gain-Controller Mode

The MAX2016 can be used as a gain controller within an automatic gain-control (AGC) loop. As shown in Figure 6, RFINA and RFINB monitor the VGA's input and output power levels, respectively. The MAX2016 produces a DC voltage at OUTD that is proportional to the difference in these two RF input power levels. An internal op amp compares the DC voltage with a reference voltage at SETD. The op amp increases or decreases the voltage at OUTD until OUTD equals SETD. Thus, the MAX2016 adjusts the gain of the VGA to a level determined by the voltage applied to SETD.

Power-Controller Mode

The MAX2016 can also be used as a power detector/controller within an AGC loop. Figure 7 depicts a scenario where the MAX2016 is employed as the AGC circuit. As shown in the figure, the MAX2016 monitors the output of the PA through a directional coupler. An internal integrator (Figure 5) compares the detected signal with a reference voltage determined by VSET_. The integrator, acting like a comparator, increases or decreases the voltage at OUT_, according to how closely the detected signal level matches the VSET_ reference. The MAX2016 maintains the power of the PA to a level determined by the voltage applied to SET_.

LF-to-2.5GHz Dual Logarithmic Detector/ Controller for Power, Gain, and VSWR Measurements

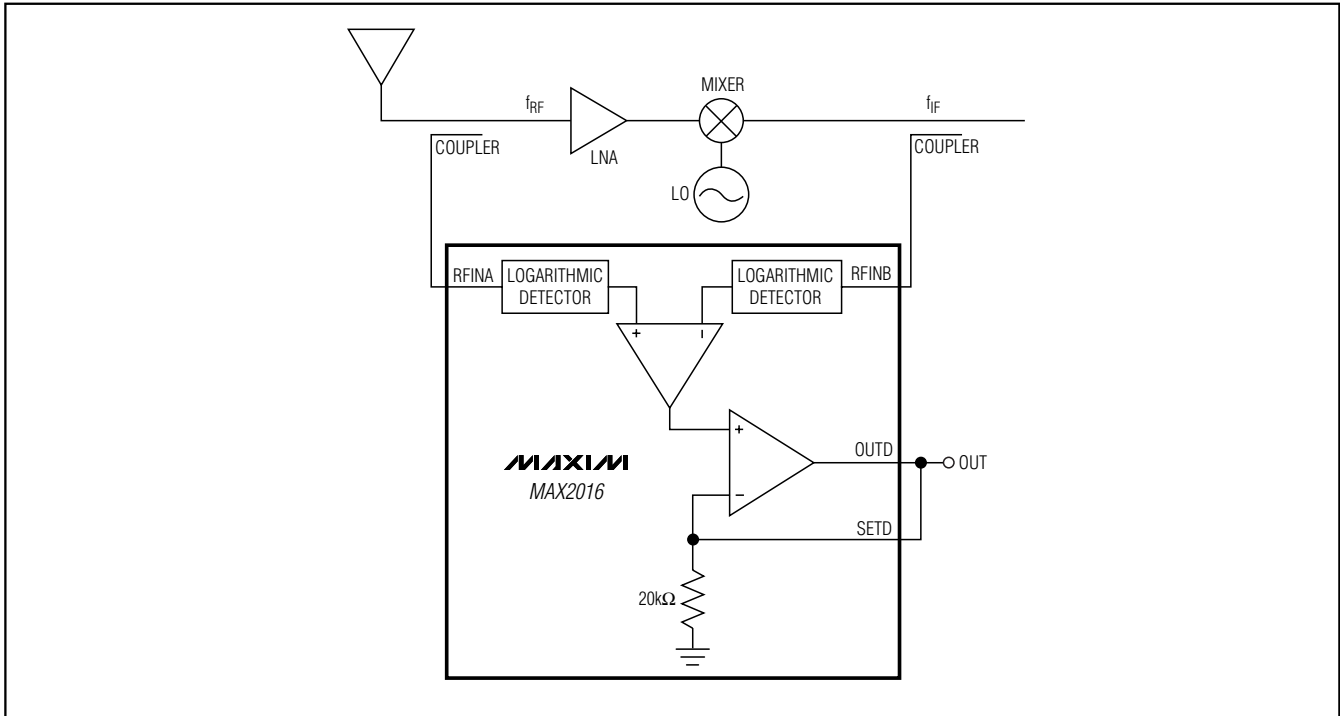

Figure 4. Conversion Gain Measurement Configuration

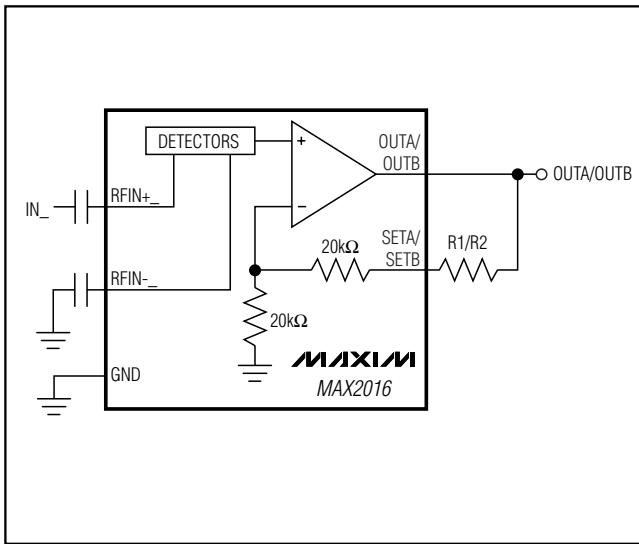

Figure 5. In Detector Mode (RSSI), OUTA/OUTB is a DC Voltage Proportional to the Input Power (**Note:** Only one detector channel is shown within the figure. Since the MAX2016 is a dual detector, the second channel can be easily implemented by using the adjacent set of input and output connections.)

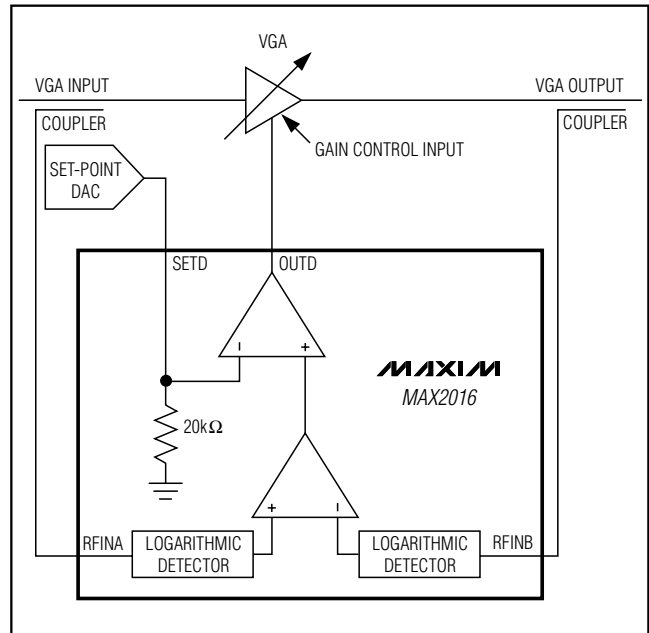

Figure 6. In Gain-Controller Mode, the OUTD Maintains the Gain of the VGA

LF-to-2.5GHz Dual Logarithmic Detector/Controller for Power, Gain, and VSWR Measurements

OUTA and OUTB Slope Adjustment

The transfer slope function of OUTA and OUTB can be increased from its nominal value by varying resistors R1 and R2 (see the *Typical Application Circuit*). The equation controlling the slope is:

$$\text{SLOPE OUTA OR OUTB} = \left(9 \frac{\text{mV}}{\text{dB}}\right) \left[\frac{(R1 \text{ or } R2) + 40\text{k}}{20\text{k}} \right]$$

OUTD Slope Adjustment

The transfer slope function of OUTD can be increased from its nominal value by varying resistor R3 (see the *Typical Application Circuit*). The equation controlling the slope is:

$$\text{SLOPE OUTD} = \left(25 \frac{\text{mV}}{\text{dB}}\right) \left(\frac{R3 + 20\text{k}}{20\text{k}} \right)$$

Input Highpass Filters

The MAX2016 integrates a programmable highpass filter on each RF input. The lower cutoff frequency of the MAX2016 can be decreased by increasing the external capacitor value between FA1 and FA2 or FB1 and FB2. By default, with no capacitor connecting FA1 and FA2 or FB1 and FB2, the lower cutoff frequency is 20MHz. Using the following equation determines the lowest operating frequency:

$$\text{frequency} = \frac{1}{2\pi RC}$$

where R = 2Ω.

Differential Output Video Filter

The bandwidth and response time difference of the output amplifier can be controlled with the external capacitor, C15, connected between FV1 and FV2. With no external capacitor, the bandwidth is greater than 20MHz. The following equation determines the bandwidth of the amplifier difference:

$$\text{frequency} = \frac{1}{2\pi RC}$$

where R = 1.8kΩ.

Comparators/Window Detectors

The MAX2016 integrates two comparators for use in monitoring the difference in power levels (gain) of RFINA and RFINB. The thresholds of the comparators are set to the voltage applied to CSETL and CSETH. The lower comparator (CSETL, COU TL) monitors the

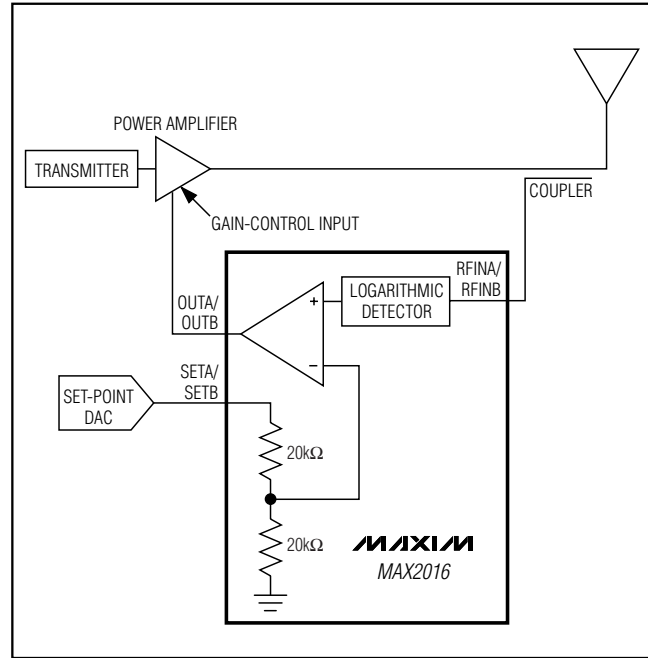

Figure 7. In Power-Controller Mode, the DC Voltage at OUTA or OUTB Controls the Gain of the PA, Leading to a Constant Output Power Level (**Note:** Only one controller channel is shown within the figure. Since the MAX2016 is a dual controller/detector, the second channel can be easily implemented by using the adjacent set of input and output connections.)

minimum gain while the upper comparator (CSETH, COU TH) monitors the maximum gain. See the window detector shown in Figure 8. The outputs of each comparator can be monitored independently or from the COR output, which ORs the outputs of each comparator making a window detector. If the difference between the two RF input powers (gain) are within the set range, COR is a logic 0. If the gain of the RF inputs is too high or too low, the COR output is a logic 1.

These comparators can be used to trigger hardware interrupts allowing rapid detection of overrange conditions.

Power-Supply Connection

The MAX2016 is designed to operate from a single +2.7V to +3.6V supply. To operate under a higher supply voltage range, a resistor must be connected in series with the power supply and VCC to reduce the voltage delivered to the chip. For a +4.75V to +5.25V supply, use a 37.4Ω (±1%) resistor in series with the supply.

Layout Considerations

A properly designed PC board is an essential part of any RF/microwave circuit. Keep RF signal lines as short

LF-to-2.5GHz Dual Logarithmic Detector/ Controller for Power, Gain, and VSWR Measurements

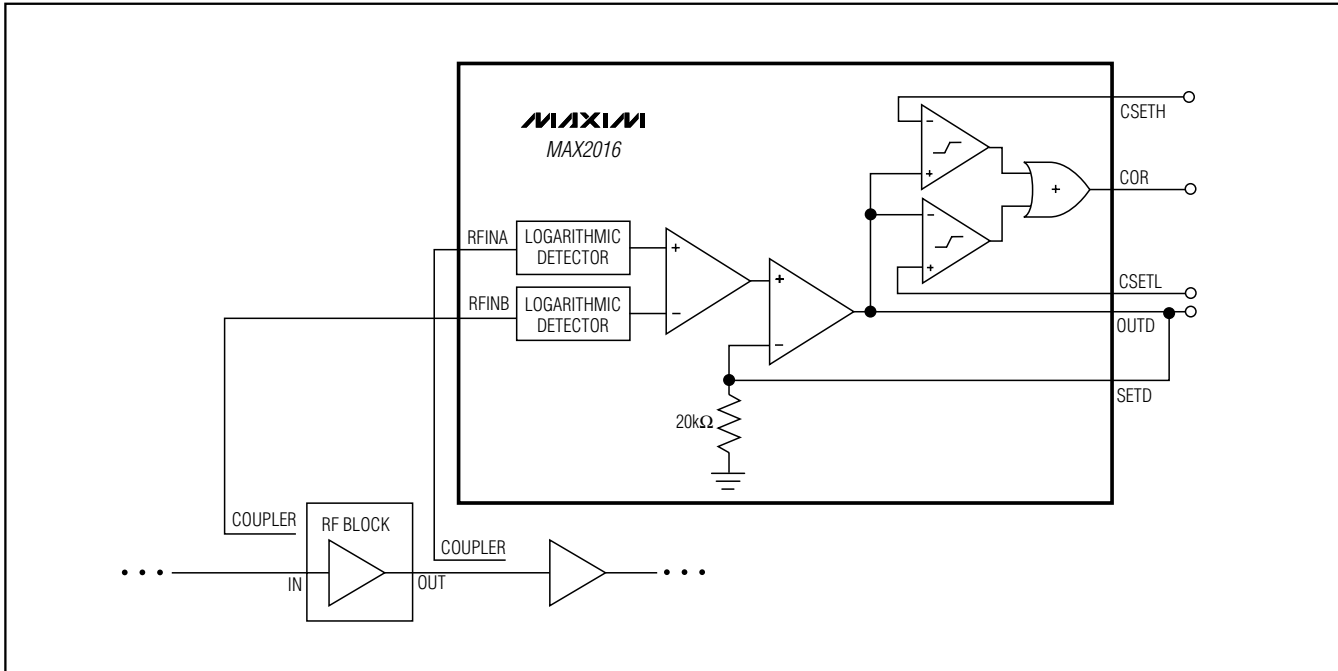

Figure 8. Window Comparators Monitoring Mode. COR goes high if OUTD drops below CSETL or rises above CSETH.

as possible to reduce losses, radiation, and inductance. For the best performance, route the ground pin traces directly to the exposed pad under the package. The PC board exposed pad **MUST** be connected to the ground plane of the PC board. It is suggested that multiple vias be used to connect this pad to the lower level ground planes. This method provides a good RF/thermal conduction path for the device. Solder the exposed pad on the bottom of the device package to the PC board. The MAX2016 Evaluation Kit can be used as a reference for board layout. Gerber files are available upon request at www.maxim-ic.com.

Power-Supply Bypassing

Proper voltage-supply bypassing is essential for high-frequency circuit stability. Bypass each VCC pin with a capacitor as close to the pin as possible (*Typical Application Circuit*).

Exposed Pad RF/Thermal Considerations

The exposed paddle (EP) of the MAX2016's 28-pin thin QFN-EP package provides two functions. One is a low thermal-resistance path to the die; the second is a low-RF impedance ground connection. The EP **MUST** be soldered to a ground plane on the PC board, either directly or through an array of plated via holes (minimum of four holes to provide ground integrity).

LF-to-2.5GHz Dual Logarithmic Detector/ Controller for Power, Gain, and VSWR Measurements

Functional Diagram

MAX2016

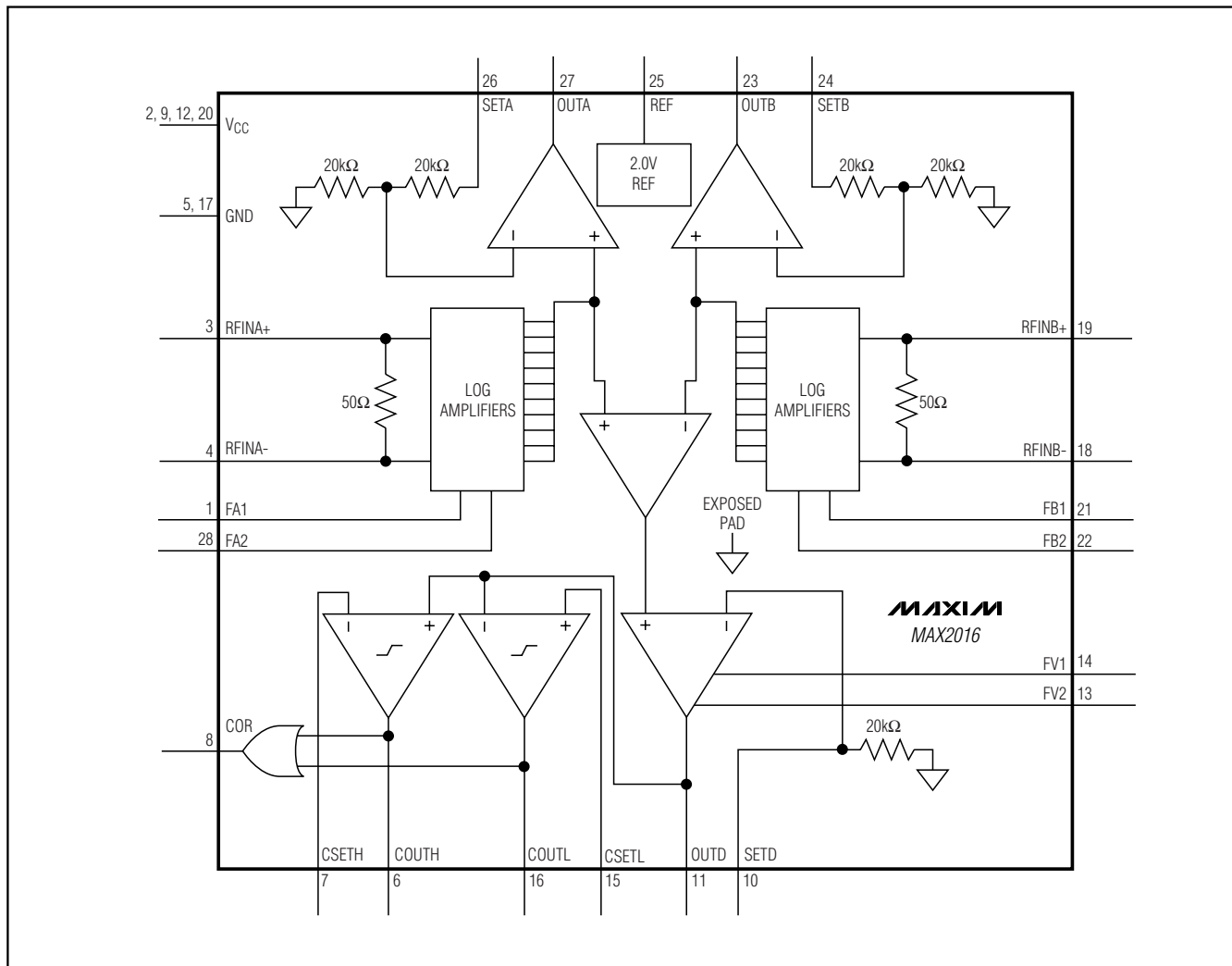

LF-to-2.5GHz Dual Logarithmic Detector/ Controller for Power, Gain, and VSWR Measurements

Typical Application Circuit

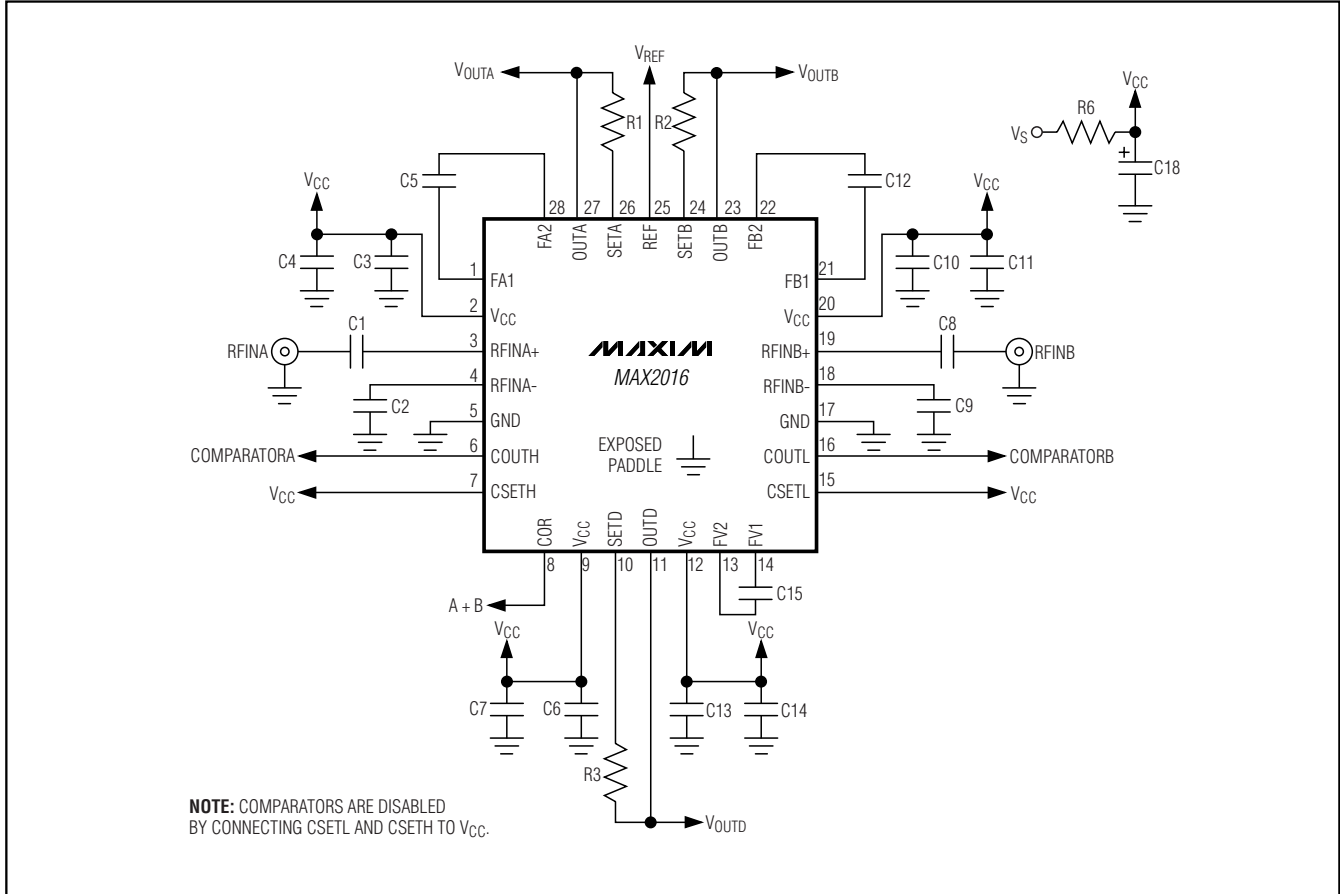

Chip Information

PROCESS: BiCMOS

LF-to-2.5GHz Dual Logarithmic Detector/ Controller for Power, Gain, and VSWR Measurements

Package Information

(The package drawing(s) in this data sheet may not reflect the most current specifications. For the latest package outline information, go to www.maxim-ic.com/packages.)

MAX2016

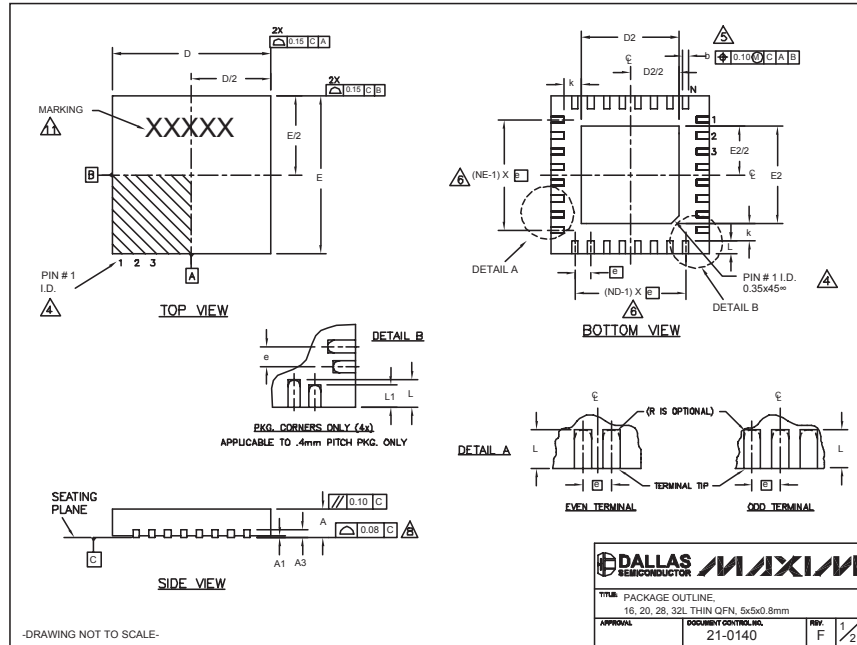

COMMON DIMENSIONS												
PKG. SYMBOL	16L 5x5			20L 5x5			28L 5x5			32L 5x5		
	MIN.	NOM.	MAX.	MIN.	NOM.	MAX.	MIN.	NOM.	MAX.	MIN.	NOM.	MAX.
A	0.70	0.75	0.80	0.70	0.75	0.80	0.70	0.75	0.80	0.70	0.75	0.80
A1	0	0.02	0.05	0	0.02	0.05	0	0.02	0.05	0	0.02	0.05
a	0.20 REF.			0.20 REF.			0.20 REF.			0.20 REF.		
b	0.25	0.30	0.35	0.25	0.30	0.35	0.20	0.25	0.30	0.20	0.25	0.30
D	4.90	5.00	5.10	4.90	5.00	5.10	4.90	5.00	5.10	4.90	5.00	5.10
E	4.90	5.00	5.10	4.90	5.00	5.10	4.90	5.00	5.10	4.90	5.00	5.10
e	0.80 BSC.			0.65 BSC.			0.50 BSC.			0.50 BSC.		
k	0.25	-	-	0.25	-	-	0.25	-	-	0.25	-	-
L	0.30	0.40	0.50	0.45	0.55	0.65	0.45	0.55	0.65	0.30	0.40	0.50
L1	-	-	-	-	-	-	-	-	-	-	-	-
N	16			20			28			32		
ND	4			5			7			8		
NE	4			5			7			8		
JEDEC	WHHB			WHHC			WHHD-1			WHHD-2		

EXPOSED PAD VARIATIONS												
PKG. CODES	D2			E2			L ±0.15	DOWN BONDS ALLOWED				
	MIN.	NOM.	MAX.	MIN.	NOM.	MAX.						
T1655-1	3.00	3.10	3.20	3.00	3.10	3.20	**	NO				
T1655-2	3.00	3.10	3.20	3.00	3.10	3.20	**	YES				
T1655N-1	3.00	3.10	3.20	3.00	3.10	3.20	**	NO				
T2055-2	3.00	3.10	3.20	3.00	3.10	3.20	**	NO				
T2055-3	3.00	3.10	3.20	3.00	3.10	3.20	**	YES				
T2055-4	3.00	3.10	3.20	3.00	3.10	3.20	**	NO				
T2055-5	3.15	3.25	3.35	3.15	3.25	3.35	0.40	Y				
T2855-1	3.15	3.25	3.35	3.15	3.25	3.35	**	NO				
T2855-2	2.60	2.70	2.80	2.60	2.70	2.80	**	NO				
T2855-3	3.15	3.25	3.35	3.15	3.25	3.35	**	YES				
T2855-4	2.60	2.70	2.80	2.60	2.70	2.80	**	YES				
T2855-5	2.60	2.70	2.80	2.60	2.70	2.80	**	NO				
T2855-6	3.15	3.25	3.35	3.15	3.25	3.35	**	NO				
T2855-7	2.60	2.70	2.80	2.60	2.70	2.80	**	YES				
T2855-8	3.15	3.25	3.35	3.15	3.25	3.35	0.40	Y				
T2855N-1	3.15	3.25	3.35	3.15	3.25	3.35	**	N				
T3255-2	3.00	3.10	3.20	3.00	3.10	3.20	**	NO				
T3255-3	3.00	3.10	3.20	3.00	3.10	3.20	**	YES				
T3255-4	3.00	3.10	3.20	3.00	3.10	3.20	**	NO				
T3255N-1	3.00	3.10	3.20	3.00	3.10	3.20	**	NO				

** SEE COMMON DIMENSIONS TABLE

DALLAS SEMICONDUCTOR **MAXIM**

TITLE: PACKAGE OUTLINE
16, 20, 28, 32L THIN QFN, 5x5x0.8mm

APPROVAL	DOCUMENT CONTROL NO. 21-0140	REV. F 2/2
----------	---------------------------------	------------

-DRAWING NOT TO SCALE-

NOTES:

1. DIMENSIONING & TOLERANCING CONFORM TO ASME Y14.5M-1994.
2. ALL DIMENSIONS ARE IN MILLIMETERS. ANGLES ARE IN DEGREES.
3. N IS THE TOTAL NUMBER OF TERMINALS.
4. THE TERMINAL #1 IDENTIFIER AND TERMINAL NUMBERING CONVENTION SHALL CONFORM TO JEDEC 95-1 SPP-012. DETAILS OF TERMINAL #1 IDENTIFIER ARE OPTIONAL BUT MUST BE LOCATED WITHIN THE ZONE INDICATED. THE TERMINAL #1 IDENTIFIER MAY BE EITHER A MOLD OR MARKED FEATURE.
5. DIMENSION b APPLIES TO METALLIZED TERMINAL AND IS MEASURED BETWEEN 0.25 mm AND 0.30 mm FROM TERMINAL TIP.
6. ND AND NE REFER TO THE NUMBER OF TERMINALS ON EACH D AND E SIDE RESPECTIVELY.
7. DEPOPULATION IS POSSIBLE IN A SYMMETRICAL FASHION.
8. COPLANARITY APPLIES TO THE EXPOSED HEAT SINK SLUG AS WELL AS THE TERMINALS.
9. DRAWING CONFORMS TO JEDEC MO220, EXCEPT EXPOSED PAD DIMENSION FOR T2855-1, T2855-3 AND T2855-6.
10. WARPAGE SHALL NOT EXCEED 0.10 mm.
11. MARKING IS FOR PACKAGE ORIENTATION REFERENCE ONLY.
12. NUMBER OF LEADS SHOWN ARE FOR REFERENCE ONLY.

Maxim cannot assume responsibility for use of any circuitry other than circuitry entirely embodied in a Maxim product. No circuit patent licenses are implied. Maxim reserves the right to change the circuitry and specifications without notice at any time.

Maxim Integrated Products, 120 San Gabriel Drive, Sunnyvale, CA 94086 408-737-7600 19