



L3G4200D

MEMS motion sensor: ultra-stable three-axis digital output gyroscope

Preliminary data

Features

- Three selectable full scales (250/500/2000 dps)
- I²C/SPI digital output interface
- 16 bit-rate value data output
- 8-bit temperature data output
- Two digital output lines (interrupt and data ready)
- Integrated low- and high-pass filters with user-selectable bandwidth
- Ultra-stable over temperature and time
- Wide supply voltage: 2.4 V to 3.6 V
- Low voltage-compatible IOs (1.8 V)
- Embedded power-down and sleep mode
- Embedded temperature sensor
- Embedded FIFO
- High shock survivability
- Extended operating temperature range (-40 °C to +85 °C)
- ECOPACK[®] RoHS and “Green” compliant

Applications

- Gaming and virtual reality input devices
- Motion control with MMI (man-machine interface)
- GPS navigation systems
- Appliances and robotics

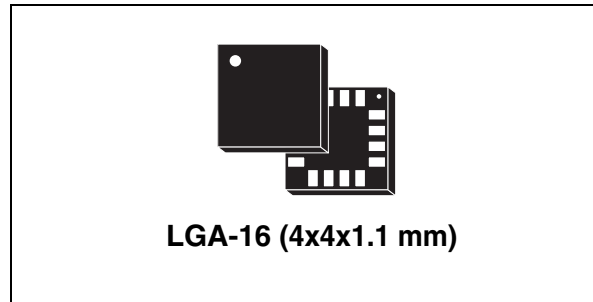

Description

The L3G4200D is a low-power three-axis angular rate sensor able to provide unprecedented stability of zero rate level and sensitivity over temperature and time. It includes a sensing element and an IC interface capable of providing the measured angular rate to the external world through a digital interface (I²C/SPI).

The sensing element is manufactured using a dedicated micro-machining process developed by STMicroelectronics to produce inertial sensors and actuators on silicon wafers.

The IC interface is manufactured using a CMOS process that allows a high level of integration to design a dedicated circuit which is trimmed to better match the sensing element characteristics.

The L3G4200D has a full scale of $\pm 250/\pm 500/\pm 2000$ dps and is capable of measuring rates with a user-selectable bandwidth.

The L3G4200D is available in a plastic land grid array (LGA) package and can operate within a temperature range of -40 °C to +85 °C.

Table 1. Device summary

Order code	Temperature range (°C)	Package	Packing
L3G4200D	-40 to +85	LGA-16 (4x4x1.1 mm)	Tray
L3G4200DTR	-40 to +85	LGA-16 (4x4x1.1 mm)	Tape and reel

Contents

1	Block diagram and pin description	7
1.1	Pin description	7
2	Mechanical and electrical characteristics	10
2.1	Mechanical characteristics	10
2.2	Electrical characteristics	11
2.3	Temperature sensor characteristics	11
2.4	Communication interface characteristics	12
2.4.1	SPI - serial peripheral interface	12
2.4.2	I2C - inter IC control interface	13
2.5	Absolute maximum ratings	14
2.6	Terminology	15
2.6.1	Sensitivity	15
2.6.2	Zero-rate level	15
2.6.3	Self-test	15
2.7	Soldering information	15
3	Main digital blocks	16
3.1	Block diagram	16
3.2	FIFO	16
3.2.1	Bypass mode	16
3.2.2	FIFO mode	17
3.2.3	Stream mode	17
3.2.4	Bypass-to-stream mode	18
3.2.5	Stream-to-FIFO mode	19
3.2.6	Retrieve data from FIFO	19
4	Application hints	20
5	Digital interfaces	21
5.1	I2C serial interface	21
5.1.1	I2C operation	22
5.2	SPI bus interface	23
5.2.1	SPI read	24

5.2.2	SPI write	25
5.2.3	SPI read in 3-wire mode	26
6	Output register mapping	27
7	Register description	29
7.1	WHO_AM_I (0Fh)	29
7.2	CTRL_REG1 (20h)	29
7.3	CTRL_REG2 (21h)	30
7.4	CTRL_REG3 (22h)	31
7.5	CTRL_REG4 (23h)	32
7.6	CTRL_REG5 (24h)	32
7.7	REFERENCE/DATACAPTURE (25h)	34
7.8	OUT_TEMP (26h)	34
7.9	STATUS_REG (27h)	34
7.10	OUT_X_L (28h), OUT_X_H (29h)	35
7.11	OUT_Y_L (2Ah), OUT_Y_H (2Bh)	35
7.12	OUT_Z_L (2Ch), OUT_Z_H (2Dh)	35
7.13	FIFO_CTRL_REG (2Eh)	35
7.14	FIFO_SRC_REG (2Fh)	35
7.15	INT1_CFG (30h)	36
7.16	INT1_SRC (31h)	36
7.17	INT1_THS_XH (32h)	37
7.18	INT1_THS_XL (33h)	37
7.19	INT1_THS_YH (34h)	37
7.20	INT1_THS_YL (35h)	38
7.21	INT1_THS_ZH (36h)	38
7.22	INT1_THS_ZL (37h)	38
7.23	INT1_DURATION (38h)	38
8	Package information	40
9	Revision history	41

List of tables

Table 1.	Device summary	1
Table 2.	Pin description	8
Table 3.	Filter values	9
Table 4.	Mechanical characteristics @ Vdd = 3.0 V, T = 25 °C, unless otherwise noted	10
Table 5.	Electrical characteristics @ Vdd =3.0 V, T=25 °C, unless otherwise noted	11
Table 6.	Temp. sensor characteristics @ Vdd =3.0 V, T=25 °C, unless otherwise noted	11
Table 7.	SPI slave timing values	12
Table 8.	I2C slave timing values	13
Table 9.	Absolute maximum ratings	14
Table 10.	PLL low-pass filter component values	20
Table 11.	Serial interface pin description	21
Table 12.	I2C terminology	21
Table 13.	SAD+read/write patterns	22
Table 14.	Transfer when master is writing one byte to slave	22
Table 15.	Transfer when master is writing multiple bytes to slave	23
Table 16.	Transfer when master is receiving (reading) one byte of data from slave	23
Table 17.	Transfer when master is receiving (reading) multiple bytes of data from slave	23
Table 18.	Register address map	27
Table 19.	WHO_AM_I register	29
Table 20.	CTRL_REG1 register	29
Table 21.	CTRL_REG1 description	29
Table 22.	DR and BW configuration setting	29
Table 23.	Power mode selection configuration	30
Table 24.	CTRL_REG2 register	30
Table 25.	CTRL_REG2 description	30
Table 26.	High pass filter mode configuration	31
Table 27.	High pass filter cut off frequency configuration [Hz]	31
Table 28.	CTRL_REG1 register	31
Table 29.	CTRL_REG3 description	31
Table 30.	CTRL_REG4 register	32
Table 31.	CTRL_REG4 description	32
Table 32.	Self test mode configuration	32
Table 33.	CTRL_REG5 register	32
Table 34.	CTRL_REG5 description	32
Table 35.	Out_Sel configuration setting	33
Table 36.	INT_SEL configuration setting	33
Table 37.	REFERENCE register	34
Table 38.	REFERENCE register description	34
Table 39.	OUT_TEMP register	34
Table 40.	OUT_TEMP register description	34
Table 41.	STATUS_REG register	34
Table 42.	STATUS_REG description	34
Table 43.	REFERENCE register	35
Table 44.	REFERENCE register description	35
Table 45.	FIFO mode configuration	35
Table 46.	FIFO_SRC register	35
Table 47.	FIFO_SRC register description	35
Table 48.	INT1_CFG register	36

Table 49.	INT1_CFG description	36
Table 50.	INT1_SRC register	36
Table 51.	INT1_SRC description	37
Table 52.	INT1_THS_XH register	37
Table 53.	INT1_THS_XH description	37
Table 54.	INT1_THS_XL register	37
Table 55.	INT1_THS_XL description	37
Table 56.	INT1_THS_YH register	37
Table 57.	INT1_THS_YH description	37
Table 58.	INT1_THS_YL register	38
Table 59.	INT1_THS_YL description	38
Table 60.	INT1_THS_ZH register	38
Table 61.	INT1_THS_ZH description	38
Table 62.	INT1_THS_ZL register	38
Table 63.	INT1_THS_ZL description	38
Table 64.	INT1_DURATION register	38
Table 65.	INT1_DURATION description	38
Table 66.	Document revision history	41

List of figures

Figure 1.	Block diagram	7
Figure 2.	Pin connection	7
Figure 3.	L3G4200D external low-pass filter values	8
Figure 4.	SPI slave timing diagram	12
Figure 5.	I2C slave timing diagram	13
Figure 6.	Block diagram	16
Figure 7.	Bypass mode	17
Figure 8.	FIFO mode	17
Figure 9.	Stream mode	18
Figure 10.	Bypass-to-stream mode	18
Figure 11.	Trigger stream mode	19
Figure 12.	L3G4200D electrical connections and external component values	20
Figure 13.	Read and write protocol	24
Figure 14.	SPI read protocol	24
Figure 15.	Multiple byte SPI read protocol (2-byte example).	25
Figure 16.	SPI write protocol	25
Figure 17.	Multiple byte SPI write protocol (2-byte example).	26
Figure 18.	SPI read protocol in 3-wire mode	26
Figure 19.	INT1_Sel and Out_Sel configuration block diagram	33
Figure 20.	Wait disabled	39
Figure 21.	Wait enabled.	39
Figure 22.	LGA-16: mechanical data and package dimensions	40

1 Block diagram and pin description

Figure 1. Block diagram

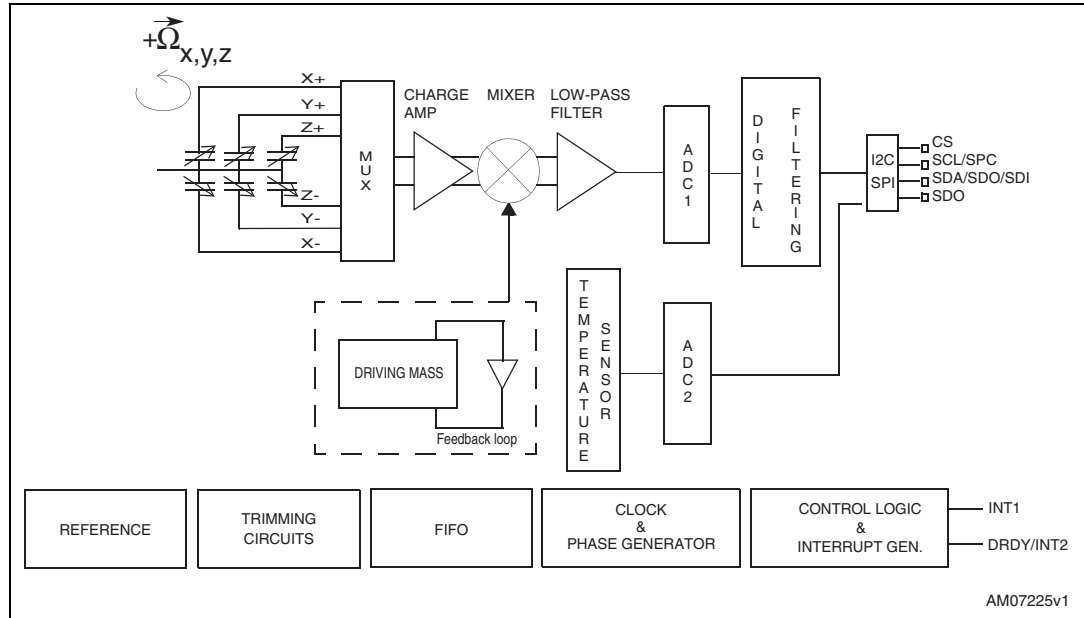

The vibration of the structure is maintained by drive circuitry in a feedback loop. The sensing signal is filtered and appears as a digital signal at the output.

1.1 Pin description

Figure 2. Pin connection

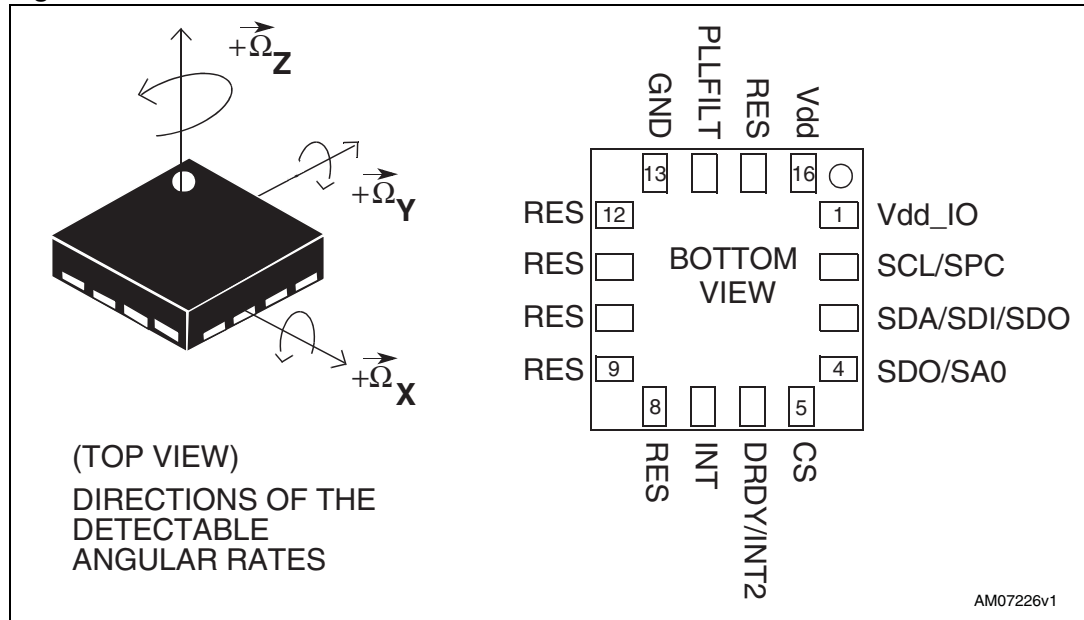
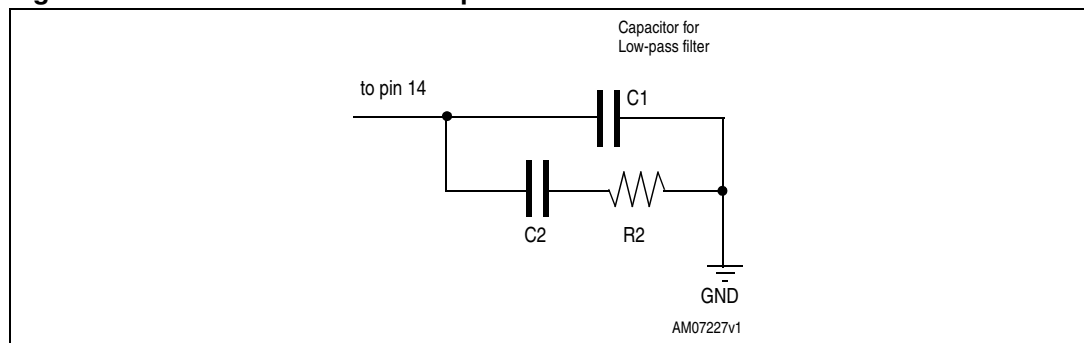

Table 2. Pin description

Pin#	Name	Function
1	Vdd_IO	Power supply for I/O pins
2	SCL SPC	I ² C serial clock (SCL) SPI serial port clock (SPC)
3	SDA SDI SDO	I ² C serial data (SDA) SPI serial data input (SDI) 3-wire interface serial data output (SDO)
4	SDO SA0	SPI serial data output (SDO) I ² C least significant bit of the device address (SA0)
5	CS	SPI enable I ² C/SPI mode selection (1:SPI idle mode / I ² C communication enabled; 0: SPI communication mode / I ² C disabled)
6	DRDY/INT2	Data ready/FIFO interrupt
7	INT1	Programmable interrupt
8	Reserved	Connect to GND
9	Reserved	Connect to GND
10	Reserved	Connect to GND
11	Reserved	Connect to GND
12	Reserved	Connect to GND
13	GND	0 V supply
14	PLLFILT	Phase-locked loop filter (see Figure 3)
15	Reserved	Connect to Vdd
16	Vdd	Power supply

Figure 3. L3G4200D external low-pass filter values (a)



a. Pin 14 PLLFILT maximum voltage level is equal to Vdd.

Table 3. Filter values

Parameter	Typical value
C1	10 nF
C2	470 nF
R2	10 k Ω

2 Mechanical and electrical characteristics

2.1 Mechanical characteristics

Table 4. Mechanical characteristics @ Vdd = 3.0 V, T = 25 °C, unless otherwise noted⁽¹⁾

Symbol	Parameter	Test condition	Min.	Typ. ⁽²⁾	Max.	Unit
FS	Measurement range	User-selectable		±250		dps
				±500		
				±2000		
So	Sensitivity	FS = 250 dps		8.75		mdps/digit
		FS = 500 dps		17.50		
		FS = 2000 dps		70		
SoDr	Sensitivity change vs. temperature	From -40 °C to +85 °C		±2		%
DVoff	Digital zero-rate level	FS = 250 dps		±10		dps
		FS = 500 dps		±15		
		FS = 2000 dps		±75		
OffDr	Zero-rate level change vs. temperature ⁽³⁾	FS = 250 dps		±0.03		dps/°C
		FS = 2000 dps		±0.04		dps/°C
NL	Non linearity ⁽⁴⁾	Best fit straight line		0.2		% FS
DST	Self-test output change	FS = 250 dps		130		dps
		FS = 500 dps		200		
		FS = 2000 dps		530		
Rn	Rate noise density	BW = 50 Hz		0.03		dps/ sqrt(Hz)
ODR	Digital output data rate			100/200/ 400/800		Hz
Top	Operating temperature range		-40		+85	°C

1. The product is factory calibrated at 3.0 V. The operational power supply range is specified in [Table 5](#).

2. Typical specifications are not guaranteed.

3. Min/max values have been estimated based on the measurements of the current gyros in production.

4. Guaranteed by design.

2.2 Electrical characteristics

Table 5. Electrical characteristics @ Vdd =3.0 V, T=25 °C, unless otherwise noted⁽¹⁾

Symbol	Parameter	Test condition	Min.	Typ. ⁽²⁾	Max.	Unit
Vdd	Supply voltage		2.4	3.0	3.6	V
Vdd_IO	I/O pins supply voltage ⁽³⁾		1.71		Vdd+0.1	V
Idd	Supply current			6.1		mA
IddSL	Supply current in sleep mode ⁽⁴⁾	Selectable by digital interface		1.5		mA
IddPdn	Supply current in power-down mode	Selectable by digital interface		5		μA
Top	Operating temperature range		-40		+85	°C

1. The product is factory calibrated at 3.0 V.
2. Typical specifications are not guaranteed.
3. It is possible to remove Vdd maintaining Vdd_IO without blocking the communication busses, in this condition the measurement chain is powered off.
4. Sleep mode introduces a faster turn-on time compared to power-down mode.

2.3 Temperature sensor characteristics

Table 6. Temp. sensor characteristics @ Vdd =3.0 V, T=25 °C, unless otherwise noted⁽¹⁾

Symbol	Parameter	Test condition	Min.	Typ. ⁽²⁾	Max.	Unit
TSDr	Temperature sensor output change vs. temperature			-1		°C/digit
TODR	Temperature refresh rate			1		Hz
Top	Operating temperature range		-40		+85	°C

1. The product is factory calibrated at 3.0 V.
2. Typical specifications are not guaranteed.

2.4 Communication interface characteristics

2.4.1 SPI - serial peripheral interface

Subject to general operating conditions for Vdd and Top.

Table 7. SPI slave timing values

Symbol	Parameter	Value ⁽¹⁾		Unit
		Min.	Max.	
tc(SPC)	SPI clock cycle	100		ns
fc(SPC)	SPI clock frequency		10	MHz
tsu(CS)	CS setup time	5		ns
th(CS)	CS hold time	8		
tsu(SI)	SDI input setup time	5		
th(SI)	SDI input hold time	15		
tv(SO)	SDO valid output time		50	
th(SO)	SDO output hold time	6		
tdis(SO)	SDO output disable time		50	

1. Values are guaranteed at 10 MHz clock frequency for SPI with both 4 and 3 wires, based on characterization results; not tested in production.

Figure 4. SPI slave timing diagram^(b)

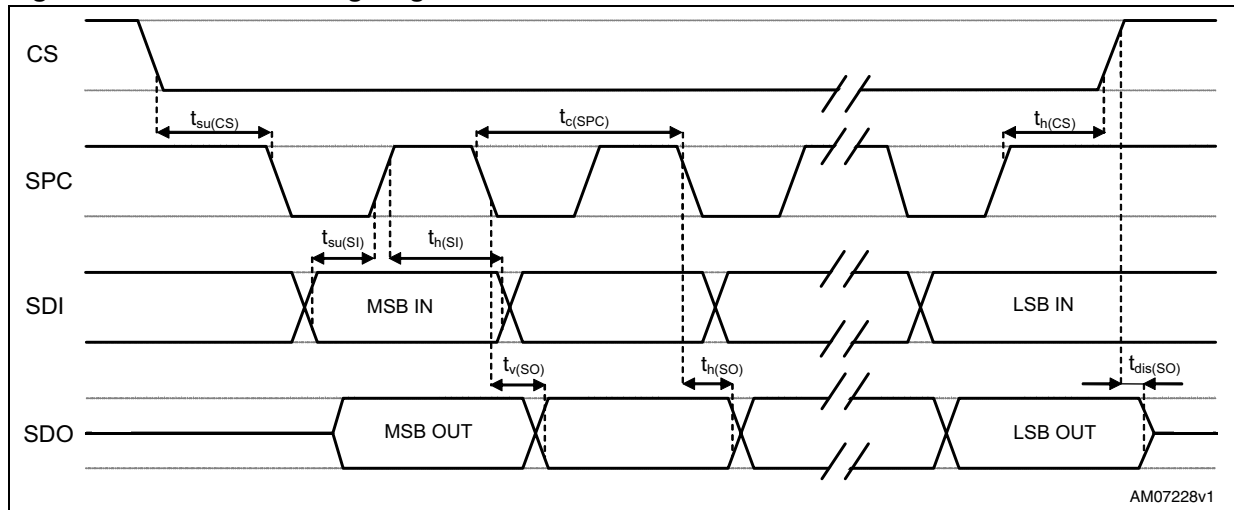

b. Measurement points are done at 0.2·Vdd_IO and 0.8·Vdd_IO, for both input and output ports.

2.4.2 I²C - inter IC control interface

Subject to general operating conditions for Vdd and Top.

Table 8. I²C slave timing values

Symbol	Parameter	I ² C standard mode ⁽¹⁾		I ² C fast mode ⁽¹⁾		Unit
		Min	Max	Min	Max	
f _(SCL)	SCL clock frequency	0	100	0	400	kHz
t _{w(SCLL)}	SCL clock low time	4.7		1.3		μs
t _{w(SCLH)}	SCL clock high time	4.0		0.6		
t _{su(SDA)}	SDA setup time	250		100		ns
t _{h(SDA)}	SDA data hold time	0	3.45	0	0.9	μs
t _{r(SDA)} t _{r(SCL)}	SDA and SCL rise time		1000	20 + 0.1C _b ⁽²⁾	300	ns
t _{f(SDA)} t _{f(SCL)}	SDA and SCL fall time		300	20 + 0.1C _b ⁽²⁾	300	
t _{h(ST)}	START condition hold time	4		0.6		μs
t _{su(SR)}	Repeated START condition setup time	4.7		0.6		
t _{su(SP)}	STOP condition setup time	4		0.6		
t _{w(SP:SR)}	Bus free time between STOP and START condition	4.7		1.3		

1. Data based on standard I²C protocol requirement; not tested in production.

2. C_b = total capacitance of one bus line, in pF.

Figure 5. I²C slave timing diagram (c)

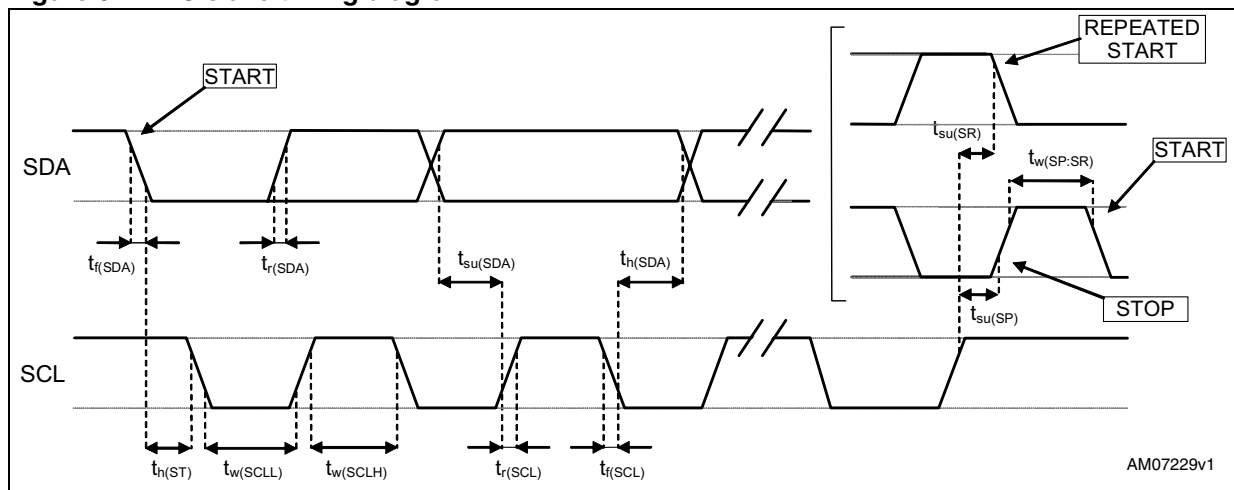

c. Measurement points are done at 0.2·Vdd_IO and 0.8·Vdd_IO, for both ports.

2.5 Absolute maximum ratings

Any stress above that listed as “Absolute maximum ratings” may cause permanent damage to the device. This is a stress rating only and functional operation of the device under these conditions is not implied. Exposure to maximum rating conditions for extended periods may affect device reliability.

Table 9. Absolute maximum ratings

Symbol	Ratings	Maximum value	Unit
Vdd	Supply voltage	-0.3 to 4.8	V
T _{STG}	Storage temperature range	-40 to +125	°C
Sg	Acceleration <i>g</i> for 0.1 ms	10,000	<i>g</i>
ESD	Electrostatic discharge protection	2 (HBM)	kV



This is a mechanical shock sensitive device, improper handling can cause permanent damage to the part



This is an ESD sensitive device, improper handling can cause permanent damage to the part

2.6 Terminology

2.6.1 Sensitivity

An angular rate gyroscope is a device that produces a positive-going digital output for counterclockwise rotation around the sensitive axis considered. Sensitivity describes the gain of the sensor and can be determined by applying a defined angular velocity to it. This value changes very little over temperature and time.

2.6.2 Zero-rate level

Zero-rate level describes the actual output signal if there is no angular rate present. The zero-rate level of precise MEMS sensors is, to some extent, a result of stress to the sensor and, therefore, the zero-rate level can slightly change after mounting the sensor onto a printed circuit board or after exposing it to extensive mechanical stress. This value changes very little over temperature and time.

2.6.3 Stability over temperature and time

Thanks to the unique single driving mass approach and optimized design, ST gyroscopes are able to guarantee a perfect match of the MEMS mechanical mass and the ASIC interface, and deliver unprecedented levels of stability over temperature and time.

With Zero rate level and sensitivity performances, up to ten times better than equivalent products now available on the market, L3G4200D allows the user to avoid any further compensation and calibration during production for faster time to market, easy application implementation, higher performances and cost saving.

2.7 Soldering information

The LGA package is compliant with the ECOPACK[®], RoHS and “Green” standard. It is qualified for soldering heat resistance according to JEDEC J-STD-020.

Leave “pin 1 Indicator” unconnected during soldering.

Land pattern and soldering recommendations are available at www.st.com/.

3 Main digital blocks

3.1 Block diagram

Figure 6. Block diagram

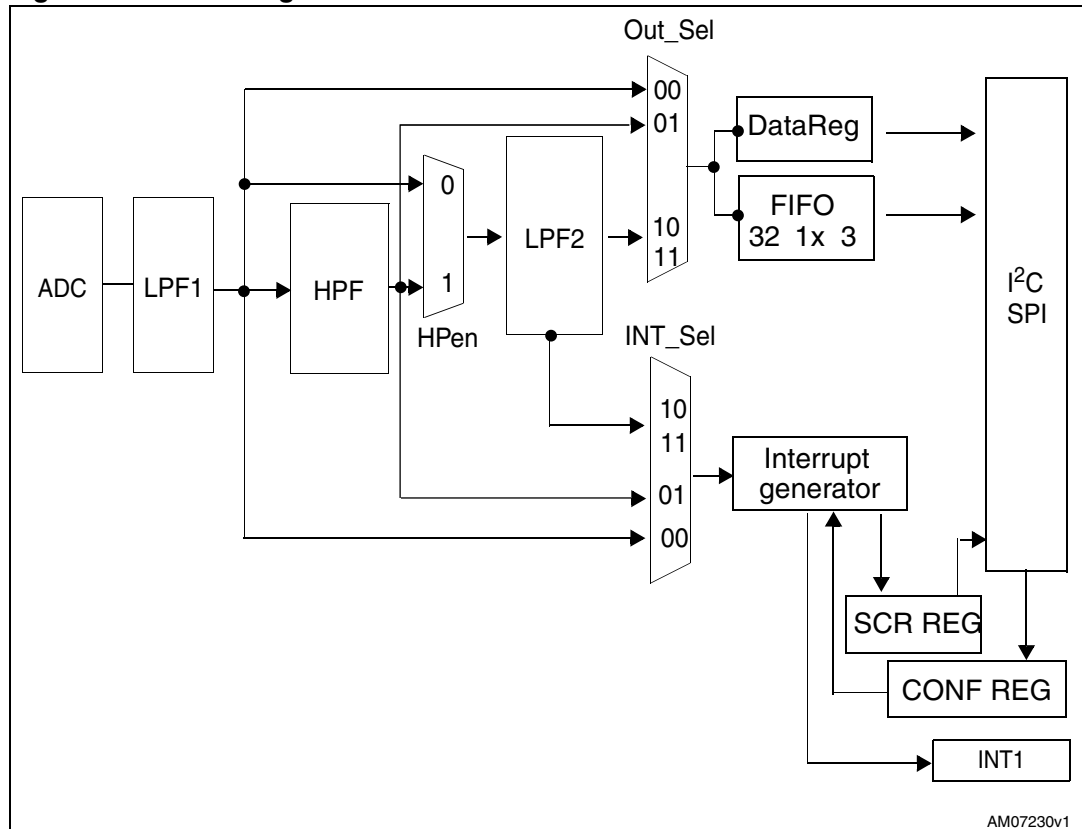

3.2 FIFO

The L3G4200D embeds a 32-slot, 16-bit data FIFO for each of the three output channels: yaw, pitch, and roll. This allows consistent power saving for the system, as the host processor does not need to continuously poll data from the sensor. Instead, it can wake up only when needed and burst the significant data out from the FIFO. This buffer can work in five different modes. Each mode is selected by the FIFO_MODE bits in the FIFO_CTRL_REG. Programmable watermark level, FIFO_empty or FIFO_Full events can be enabled to generate dedicated interrupts on the DRDY/INT2 pin (configured through CTRL_REG3), and event detection information is available in FIFO_SRC_REG. The watermark level can be configured to WTM4:0 in FIFO_CTRL_REG.

3.2.1 Bypass mode

In bypass mode, the FIFO is not operational and for this reason it remains empty. As illustrated in [Figure 7](#), only the first address is used for each channel. The remaining FIFO slots are empty. When new data is available, the old data is overwritten.

Figure 7. Bypass mode

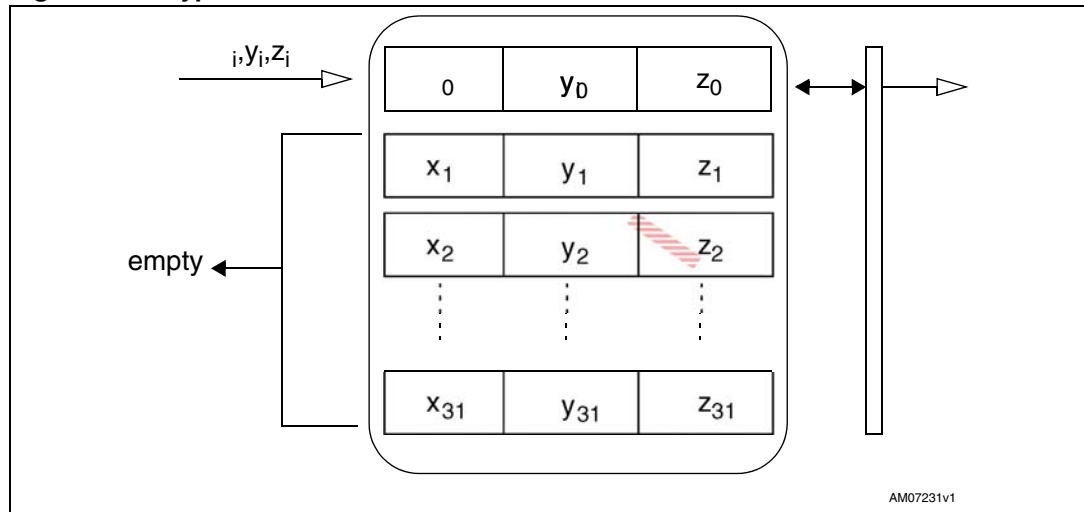

3.2.2 FIFO mode

In FIFO mode, data from the yaw, pitch, and roll channels are stored in the FIFO. A watermark interrupt can be enabled (I2_WMK bit in CTRL_REG3), which is triggered when the FIFO is filled to the level specified in the WTM 4:0 bits of FIFO_CTRL_REG. The FIFO continues filling until it is full (32 slots of 16-bit data for yaw, pitch, and roll). When full, the FIFO stops collecting data from the input channels. To restart data collection, it is necessary to write FIFO_CTRL_REG back to bypass mode.

FIFO mode is represented in [Figure 8](#).

Figure 8. FIFO mode

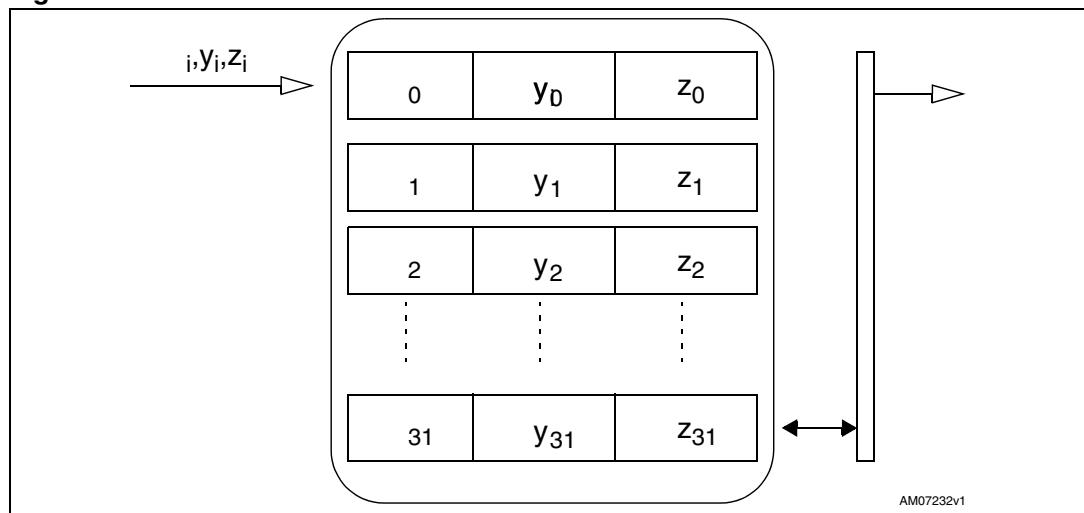

3.2.3 Stream mode

In stream mode, data from yaw, pitch, and roll measurements are stored in the FIFO. A watermark interrupt can be enabled and set as in FIFO mode. The FIFO continues filling until full (32 slots of 16-bit data for yaw, pitch, and roll). When full, the FIFO discards the

older data as the new data arrives. Programmable watermark level events can be enabled to generate dedicated interrupts on the DRDY/INT2 pin (configured through CTRL_REG3).

Stream mode is represented in [Figure 9](#).

Figure 9. Stream mode

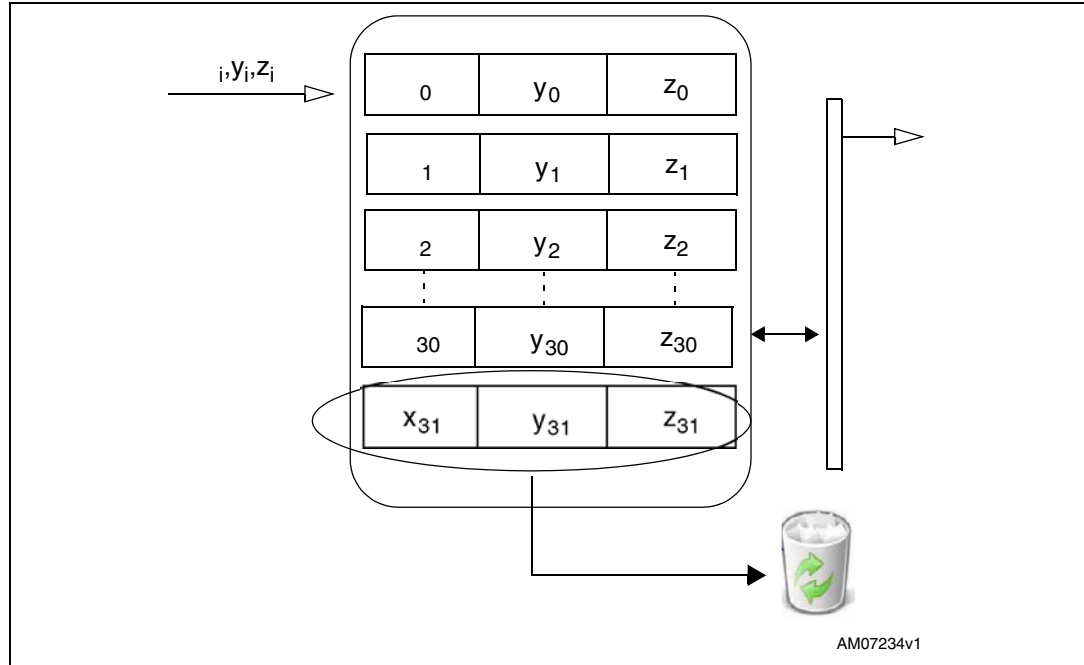

3.2.4 Bypass-to-stream mode

In bypass-to-stream mode, the FIFO starts operating in bypass mode, and once a trigger event occurs (related to INT1_CFG register events), the FIFO starts operating in stream mode (see [Figure 10](#)).

Figure 10. Bypass-to-stream mode

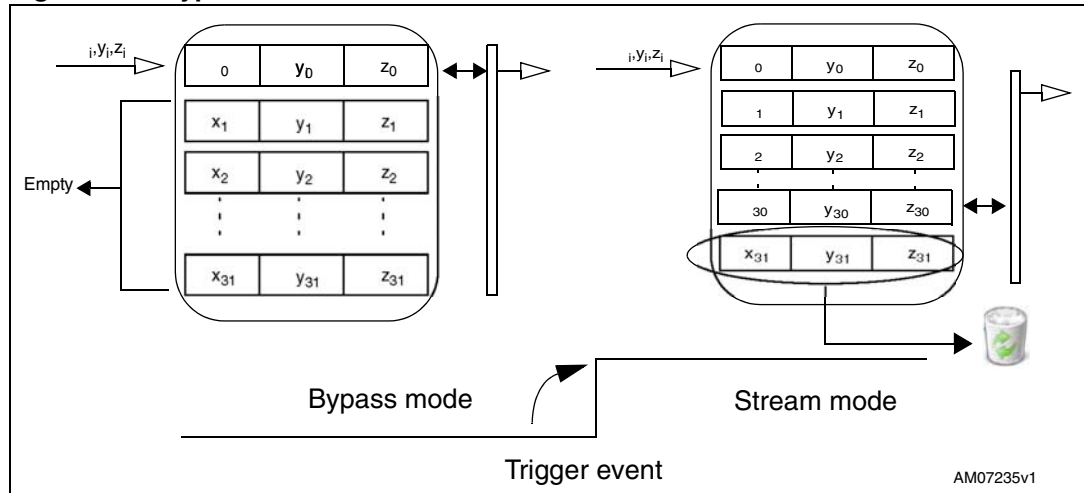

3.2.5 Stream-to-FIFO mode

In stream-to-FIFO mode, data from yaw, pitch, and roll measurements are stored in the FIFO. A watermark interrupt can be enabled on pin DRDY/INT2, setting the I2_WTM bit in CTRL_REG3, which is triggered when the FIFO is filled to the level specified in the WTM4:0 bits of FIFO_CTRL_REG. The FIFO continues filling until full (32 slots of 16-bit data for yaw, pitch, and roll). When full, the FIFO discards the older data as the new data arrives. Once a trigger event occurs (related to INT1_CFG register events), the FIFO starts operating in FIFO mode (see [Figure 11](#)).

Figure 11. Trigger stream mode

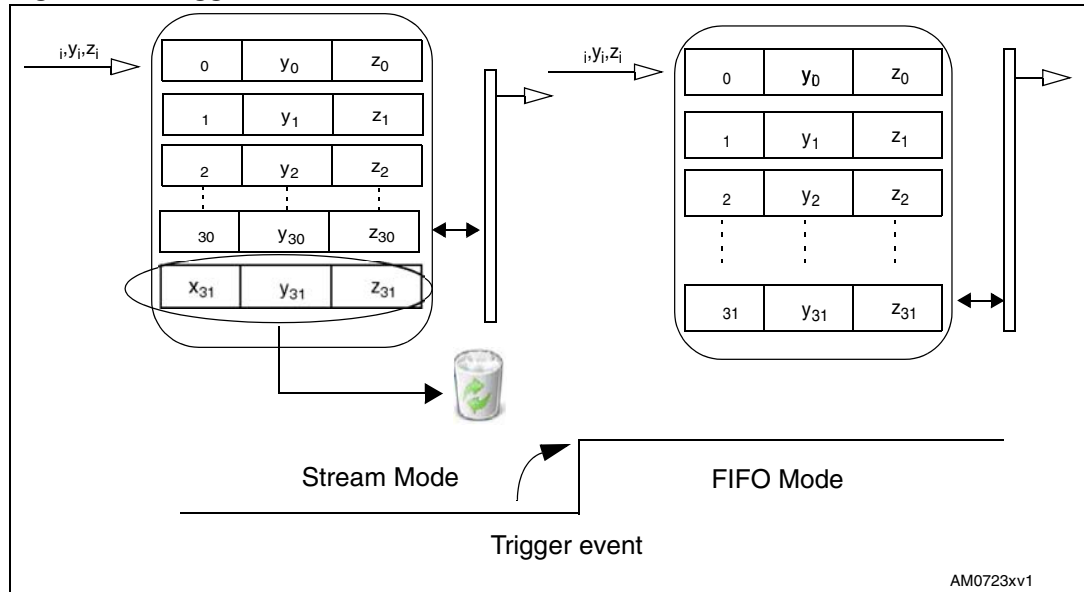

3.2.6 Retrieve data from FIFO

FIFO data is read through the OUT_X, OUT_Y and OUT_Z registers. When the FIFO is in stream, trigger or FIFO mode, a read operation to the OUT_X, OUT_Y or OUT_Z registers provides the data stored in the FIFO. Each time data is read from the FIFO, the oldest pitch, roll, and yaw data are placed in the OUT_X, OUT_Y and OUT_Z registers and both single read and read_burst (X, Y & Z with auto-incremental address) operations can be used. In read_burst mode, when data included in OUT_Z_H is read, the system again starts to read information from addr OUT_X_L.

4 Application hints

Figure 12. L3G4200D electrical connections and external component values

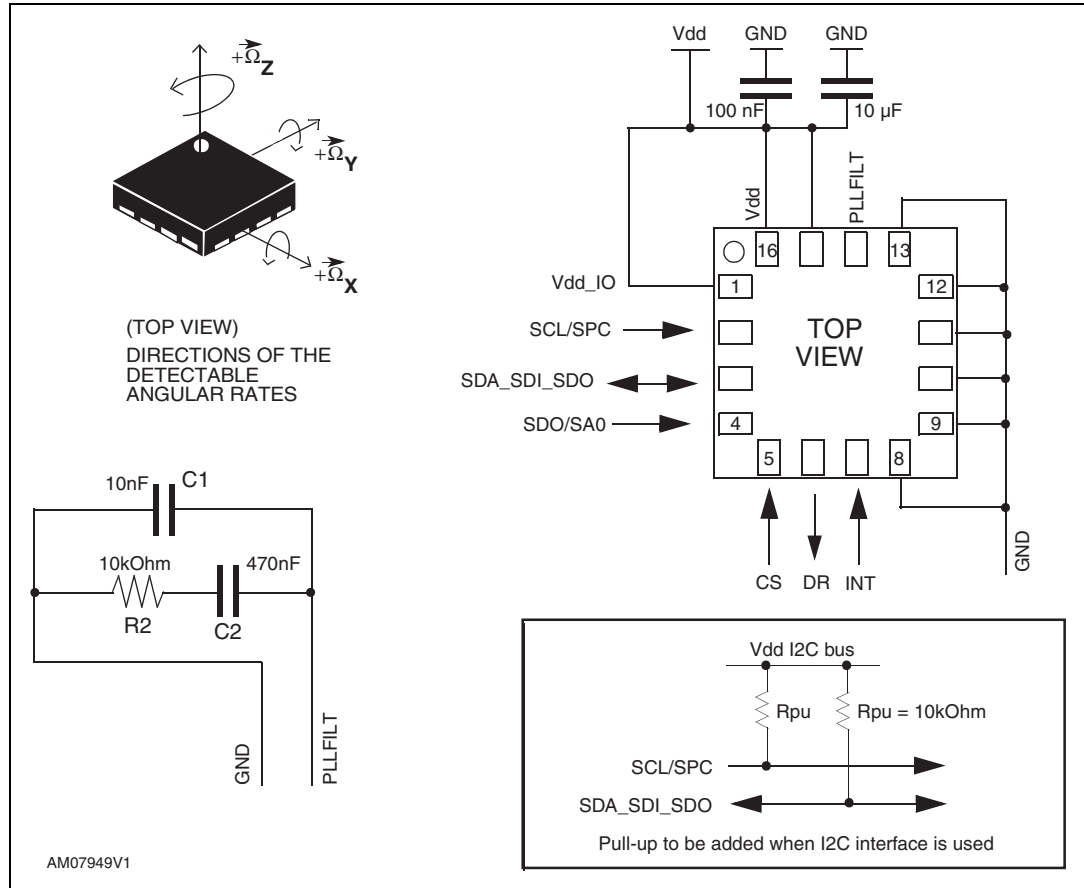

Power supply decoupling capacitors (100 nF ceramic or polyester +10 μF) should be placed as near as possible to the device (common design practice).

If Vdd and Vdd_IO are not connected together, power supply decoupling capacitors (100 nF and 10 μF between Vdd and common ground, 100 nF between Vdd_IO and common ground) should be placed as near as possible to the device (common design practice).

The L3G4200D IC includes a PLL (phase locked loop) circuit to synchronize driving and sensing interfaces. Capacitors and resistors must be added at the **PLLFILT** pin (as shown in [Figure 12](#)) to implement a second-order low-pass filter. [Table 10](#) summarizes the PLL low-pass filter component values.

Table 10. PLL low-pass filter component values

Component	Value
C1	10 nF ± 10 %
C2	470 nF ± 10 %
R2	10 kΩ ± 10 %

5 Digital interfaces

The registers embedded in the L3G4200D may be accessed through both the I²C and SPI serial interfaces. The latter may be software-configured to operate either in 3-wire or 4-wire interface mode.

The serial interfaces are mapped onto the same pins. To select/exploit the I²C interface, the CS line must be tied high (i.e., connected to Vdd_IO).

Table 11. Serial interface pin description

Pin name	Pin description
CS	SPI enable I ² C/SPI mode selection (1:SPI idle mode / I ² C communication enabled; 0: SPI communication mode / I ² C disabled)
SCL/SPC	I ² C serial clock (SCL) SPI serial port clock (SPC)
SDA/SDI/SDO	I ² C serial data (SDA) SPI serial data input (SDI) 3-wire interface serial data output (SDO)
SDO	SPI serial data output (SDO) I ² C least significant bit of the device address

5.1 I²C serial interface

The L3G4200D I²C is a bus slave. The I²C is employed to write data to registers whose content can also be read back.

The relevant I²C terminology is given in the table below.

Table 12. I²C terminology

Term	Description
Transmitter	The device which sends data to the bus
Receiver	The device which receives data from the bus
Master	The device which initiates a transfer, generates clock signals and terminates a transfer
Slave	The device addressed by the master

There are two signals associated with the I²C bus: the serial clock line (SCL) and the serial data line (SDA). The latter is a bidirectional line used for sending and receiving the data to/from the interface. Both lines must be connected to Vdd_IO through an external pull-up resistor. When the bus is free both the lines are high.

The I²C interface is compliant with fast mode (400 kHz) I²C standards as well as with normal mode.

5.1.1 I²C operation

The transaction on the bus is started through a START (ST) signal. A START condition is defined as a HIGH to LOW transition on the data line while the SCL line is held HIGH. After this has been transmitted by the master, the bus is considered busy. The next byte of data transmitted after the start condition contains the address of the slave in the first 7 bits and the eighth bit tells whether the master is receiving data from the slave or transmitting data to the slave. When an address is sent, each device in the system compares the first 7 bits after a start condition with its address. If they match, the device considers itself addressed by the master.

The slave address (SAD) associated with the L3G4200D is 110100xb. The SDO pin can be used to modify the least significant bit (LSb) of the device address. If the SDO pin is connected to the voltage supply, LSb is '1' (address 1101001b). Otherwise, if the SDO pin is connected to ground, the LSb value is '0' (address 1101000b). This solution permits the connection and addressing of two different gyroscopes to the same I²C bus.

Data transfer with acknowledge is mandatory. The transmitter must release the SDA line during the acknowledge pulse. The receiver must then pull the data line LOW so that it remains stable low during the HIGH period of the acknowledge clock pulse. A receiver which has been addressed is obliged to generate an acknowledge after each byte of data received.

The I²C embedded in the L3G4200D behaves like a slave device, and the following protocol must be adhered to. After the START (ST) condition, a slave address is sent. Once a slave acknowledge (SAK) has been returned, an 8-bit sub-address is transmitted. The 7 LSb represent the actual register address while the MSB enables address auto-increment. If the MSb of the SUB field is 1, the SUB (register address) is automatically incremented to allow multiple data read/write.

The slave address is completed with a read/write bit. If the bit is '1' (read), a REPEATED START (SR) condition must be issued after the two sub-address bytes; if the bit is '0' (write) the master transmits to the slave with the direction unchanged. [Table 13](#) describes how the SAD+read/write bit pattern is composed, listing all the possible configurations.

Table 13. SAD+read/write patterns

Command	SAD[6:1]	SAD[0] = SDO	R/W	SAD+R/W
Read	110100	0	1	11010001 (D1h)
Write	110100	0	0	11010000 (D0h)
Read	110100	1	1	11010011 (D3h)
Write	110100	1	0	11010010 (D2h)

Table 14. Transfer when master is writing one byte to slave

Master	ST	SAD + W		SUB		DATA		SP
Slave			SAK		SAK		SAK	

Table 15. Transfer when master is writing multiple bytes to slave

Master	ST	SAD + W		SUB		DATA		DATA		SP
Slave			SAK		SAK		SAK		SAK	

Table 16. Transfer when master is receiving (reading) one byte of data from slave

Master	ST	SAD + W		SUB		SR	SAD + R			NMAK	SP
Slave			SAK		SAK			SAK	DATA		

Table 17. Transfer when master is receiving (reading) multiple bytes of data from slave

Master	ST	SAD+W		SUB		SR	SAD+R			MAK		MAK		NMAK	SP
Slave			SAK		SAK			SAK	DATA		DATA		DATA		

Data are transmitted in byte format (DATA). Each data transfer contains 8 bits. The number of bytes transferred per transfer is unlimited. Data is transferred with the most significant bit (MSb) first. If a receiver cannot receive another complete byte of data until it has performed some other function, it can hold the clock line SCL LOW to force the transmitter into a wait state. Data transfer only continues when the receiver is ready for another byte and releases the data line. If a slave receiver does not acknowledge the slave address (i.e., it is not able to receive because it is performing some real-time function) the data line must be left HIGH by the slave. The master can then abort the transfer. A LOW to HIGH transition on the SDA line while the SCL line is HIGH is defined as a STOP condition. Each data transfer must be terminated by the generation of a STOP (SP) condition.

In order to read multiple bytes, it is necessary to assert the most significant bit of the sub-address field. In other words, SUB(7) must be equal to 1, while SUB(6-0) represents the address of the first register to be read.

In the presented communication format, MAK is “master acknowledge” and NMAK is “no master acknowledge”.

5.2 SPI bus interface

The SPI is a bus slave. The SPI allows writing and reading of the device registers. The serial interface interacts with the external world through 4 wires: **CS**, **SPC**, **SDI**, and **SDO**.

Figure 13. Read and write protocol

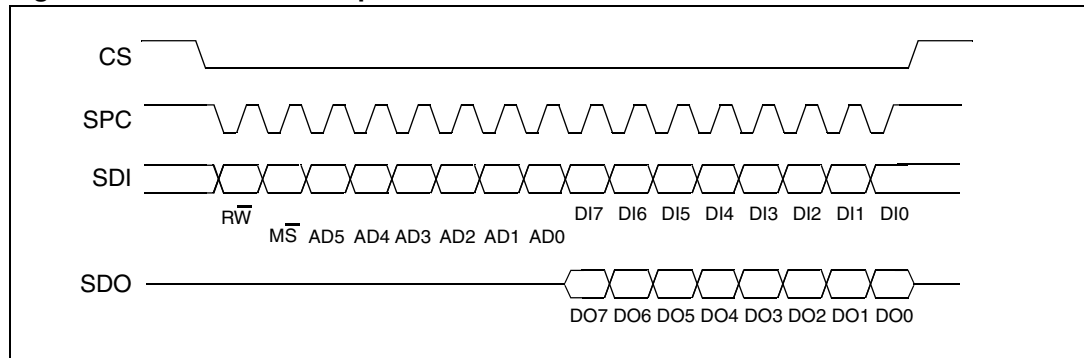

CS is the serial port enable and is controlled by the SPI master. It goes low at the start of the transmission and returns to high at the end. **SPC** is the serial port clock and is controlled by the SPI master. It is stopped high when **CS** is high (no transmission). **SDI** and **SDO** are, respectively, the serial port data input and output. These lines are driven at the falling edge of **SPC** and should be captured at the rising edge of **SPC**.

Both the read register and write register commands are completed in 16 clock pulses, or in multiples of 8 in case of multiple read/write bytes. Bit duration is the time between two falling edges of **SPC**. The first bit (bit 0) starts at the first falling edge of **SPC** after the falling edge of **CS** while the last bit (bit 15, bit 23, etc.) starts at the last falling edge of **SPC** just before the rising edge of **CS**.

Bit 0: \overline{RW} bit. When 0, the data DI(7:0) is written to the device. When 1, the data DO(7:0) from the device is read. In the latter case, the chip drives **SDO** at the start of bit 8.

Bit 1: \overline{MS} bit. When 0, the address remains unchanged in multiple read/write commands. When 1, the address is auto-incremented in multiple read/write commands.

Bit 2-7: address AD(5:0). This is the address field of the indexed register.

Bit 8-15: data DI(7:0) (write mode). This is the data that is written to the device (MSb first).

Bit 8-15: data DO(7:0) (read mode). This is the data that is read from the device (MSb first).

In multiple read/write commands, further blocks of 8 clock periods are added. When the \overline{MS} bit is 0, the address used to read/write data remains the same for every block. When the \overline{MS} bit is 1, the address used to read/write data is incremented at every block.

The function and the behavior of **SDI** and **SDO** remain unchanged.

5.2.1 SPI read

Figure 14. SPI read protocol

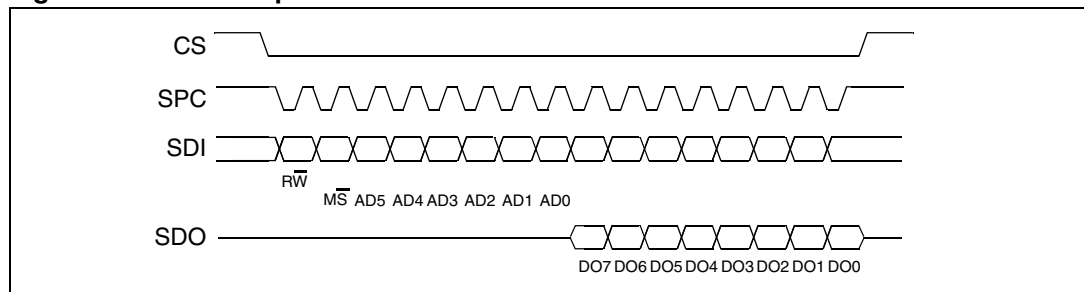

The SPI read command is performed with 16 clock pulses. A multiple byte read command is performed by adding blocks of 8 clock pulses to the previous one.

Bit 0: READ bit. The value is 1.

Bit 1: \overline{MS} bit. When 0, do not increment address; when 1, increment address in multiple reading.

Bit 2-7: address AD(5:0). This is the address field of the indexed register.

Bit 8-15: data DO(7:0) (read mode). This is the data that is read from the device (MSb first).

Bit 16-... : data DO(...-8). Further data in multiple byte reading.

Figure 15. Multiple byte SPI read protocol (2-byte example)

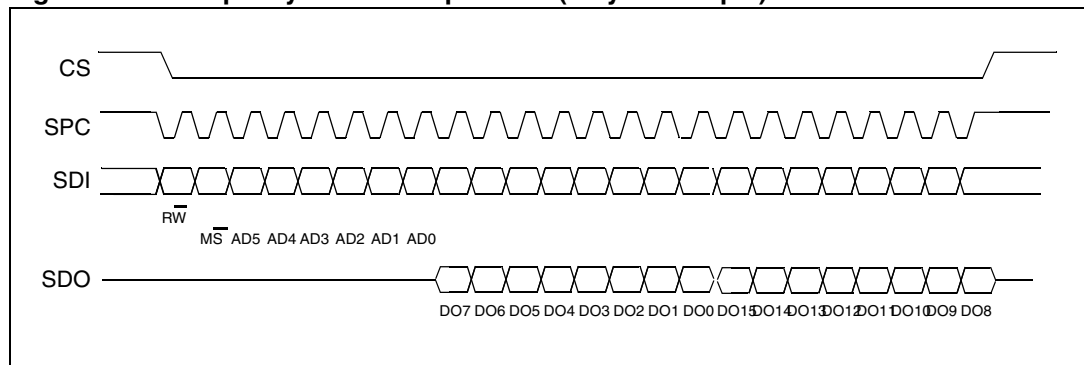

5.2.2 SPI write

Figure 16. SPI write protocol

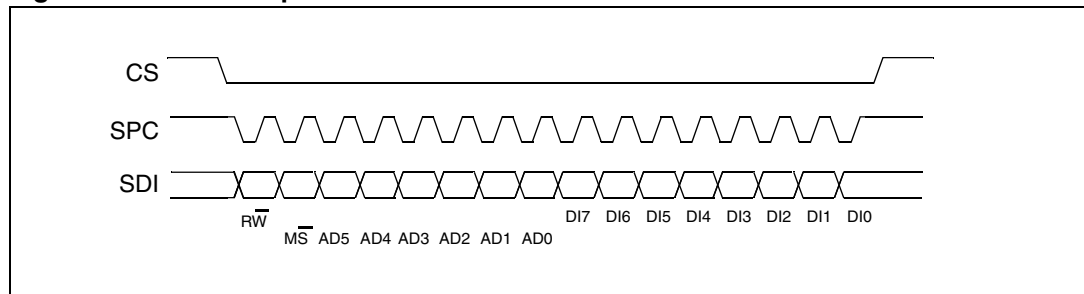

The SPI write command is performed with 16 clock pulses. A multiple byte write command is performed by adding blocks of 8 clock pulses to the previous one.

Bit 0: WRITE bit. The value is 0.

Bit 1: \overline{MS} bit. When 0, do not increment address; when 1, increment address in multiple writing.

Bit 2 -7: address AD(5:0). This is the address field of the indexed register.

Bit 8-15: data DI(7:0) (write mode). This is the data that is written to the device (MSb first).

Bit 16-... : data DI(...-8). Further data in multiple byte writing.

Figure 17. Multiple byte SPI write protocol (2-byte example)

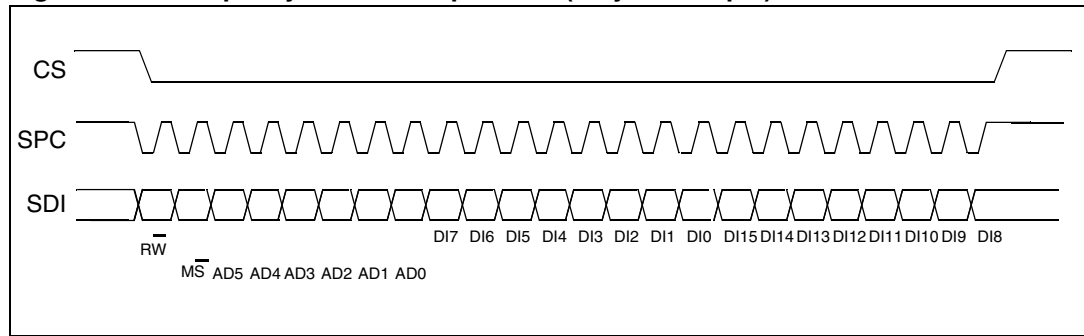

5.2.3 SPI read in 3-wire mode

3-wire mode is entered by setting the SIM (SPI serial interface mode selection) bit to 1 in CTRL_REG2.

Figure 18. SPI read protocol in 3-wire mode

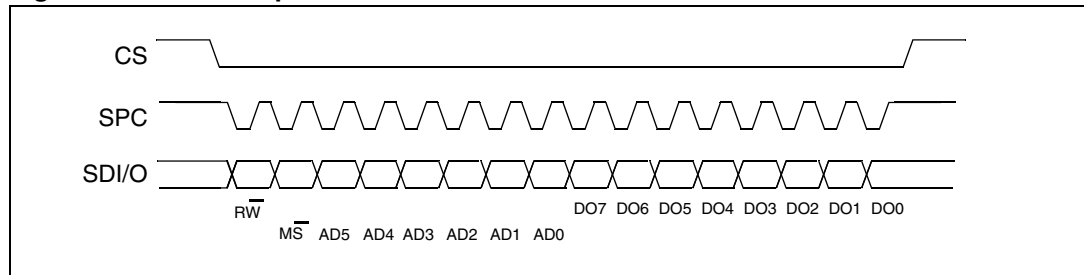

The SPI read command is performed with 16 clock pulses:

Bit 0: READ bit. The value is 1.

Bit 1: \overline{MS} bit. When 0, do not increment address; when 1, increment address in multiple reading.

Bit 2-7: address AD(5:0). This is the address field of the indexed register.

Bit 8-15: data DO(7:0) (read mode). This is the data that is read from the device (MSb first).

The multiple read command is also available in 3-wire mode.

6 Output register mapping

The table given below provides a listing of the 8 bit registers embedded in the device and the related addresses:

Table 18. Register address map

Name	Type	Register address		Default	Comment
		Hex	Binary		
Reserved	-	00-0E	-	-	
WHO_AM_I	r	0F	000 1111	11010011	
Reserved	-	10-1F	-	-	
CTRL_REG1	rw	20	010 0000	00000111	
CTRL_REG2	rw	21	010 0001	00000000	
CTRL_REG3	rw	22	010 0010	00000000	
CTRL_REG4	rw	23	010 0011	00000000	
CTRL_REG5	rw	24	010 0100	00000000	
REFERENCE	rw	25	010 0101	00000000	
OUT_TEMP	r	26	010 0110	output	
STATUS_REG	r	27	010 0111	output	
OUT_X_L	r	28	010 1000	output	
OUT_X_H	r	29	010 1001	output	
OUT_Y_L	r	2A	010 1010	output	
OUT_Y_H	r	2B	010 1011	output	
OUT_Z_L	r	2C	010 1100	output	
OUT_Z_H	r	2D	010 1101	output	
FIFO_CTRL_REG	rw	2E	010 1110	00000000	
FIFO_SRC_REG	r	2F	010 1111	output	
INT1_CFG	rw	30	011 0000	00000000	
INT1_SRC	r	31	011 0001	output	
INT1_TSH_XH	rw	32	011 0010	00000000	
INT1_TSH_XL	rw	33	011 0011	00000000	
INT1_TSH_YH	rw	34	011 0100	00000000	
INT1_TSH_YL	rw	35	011 0101	00000000	
INT1_TSH_ZH	rw	36	011 0110	00000000	
INT1_TSH_ZL	rw	37	011 0111	00000000	
INT1_DURATION	rw	38	011 1000	00000000	

Registers marked as *Reserved* must not be changed. The writing to those registers may cause permanent damages to the device.

The content of the registers that are loaded at boot should not be changed. They contain the factory calibration values. Their content is automatically restored when the device is powered-up.

7 Register description

The device contains a set of registers which are used to control its behavior and to retrieve acceleration data. The registers address, made of 7 bits, is used to identify them and to write the data through serial interface.

7.1 WHO_AM_I (0Fh)

Table 19. WHO_AM_I register

1	1	0	1	0	0	1	1
---	---	---	---	---	---	---	---

Device identification register.

7.2 CTRL_REG1 (20h)

Table 20. CTRL_REG1 register

DR1	DR0	BW1	BW0	PD	Zen	Yen	Xen
-----	-----	-----	-----	----	-----	-----	-----

Table 21. CTRL_REG1 description

DR1-DR0	Output Data Rate selection. Refer to Table 22
BW1-BW0	Bandwidth selection. Refer to Table 22
PD	Power down mode enable. Default value: 0 (0: power down mode, 1: normal mode or sleep mode)
Zen	Z axis enable. Default value: 1 (0: Z axis disabled; 1: Z axis enabled)
Yen	Y axis enable. Default value: 1 (0: Y axis disabled; 1: Y axis enabled)
Xen	X axis enable. Default value: 1 (0: X axis disabled; 1: X axis enabled)

DR<1:0> is used to set ODR selection. **BW <1:0>** is used to set Bandwidth selection.

In the following table are reported all frequency resulting in combination of DR / BW bits.

Table 22. DR and BW configuration setting

DR <1:0>	BW <1:0>	ODR [Hz]	Cut-Off
00	00	100	12.5
00	01	100	25
00	10	100	25
00	11	100	25

Table 22. DR and BW configuration setting (continued)

DR <1:0>	BW <1:0>	ODR [Hz]	Cut-Off
01	00	200	12.5
01	01	200	25
01	10	200	50
01	11	200	70
10	00	400	20
10	01	400	25
10	10	400	50
10	11	400	110
11	00	800	30
11	01	800	35
11	10	800	50
11	11	800	110

Combination of **PD**, **Zen**, **Yen**, **Xen** are used to set device in different modes (power down / normal / sleep mode) according with the following table.

Table 23. Power mode selection configuration

Mode	PD	Zen	Yen	Xen
Power down	0	-	-	-
Sleep	1	0	0	0
Normal	1	-	-	-

7.3 CTRL_REG2 (21h)

Table 24. CTRL_REG2 register

0 ⁽¹⁾	0 ⁽¹⁾	HPM1	HPM1	HPCF3	HPCF2	HPCF1	HPCF0
------------------	------------------	------	------	-------	-------	-------	-------

1. Value loaded at boot. This value must not be changed

Table 25. CTRL_REG2 description

HPM1- HPM0	High Pass filter Mode Selection. Default value: 00 Refer to Table 26
HPCF3- HPCF0	High Pass filter Cut Off frequency selection Refer to Table 28

Table 26. High pass filter mode configuration

HPM1	HPM0	High Pass filter Mode
0	0	Normal mode (reset reading HP_RESET_FILTER)
0	1	Reference signal for filtering
1	0	Normal mode
1	1	Autoreset on interrupt event

Table 27. High pass filter cut off frequency configuration [Hz]

HPCF3	ODR= 100 Hz	ODR= 200 Hz	ODR= 400 Hz	ODR= 800 Hz
0000	8	15	30	56
0001	4	8	15	30
0010	2	4	8	15
0011	1	2	4	8
0100	0.5	1	2	4
0101	0.2	0.5	1	2
0110	0.1	0.2	0.5	1
0111	0.05	0.1	0.2	0.5
1000	0.02	0.05	0.1	0.2
1001	0.01	0.02	0.05	0.1

7.4 CTRL_REG3 (22h)

Table 28. CTRL_REG1 register

I1_Int1	I1_Boot	H_Lactive	PP_OD	I2_DRDY	I2_WTM	I2_ORun	I2_Empty
---------	---------	-----------	-------	---------	--------	---------	----------

Table 29. CTRL_REG3 description

I1_Int1	Interrupt enable on INT1 pin. Default value 0. (0: Disable; 1: Enable)
I1_Boot	Boot status available on INT1. Default value 0. (0: Disable; 1: Enable)
H_Lactive	Interrupt active configuration on INT1. Default value 0. (0: High; 1:Low)
PP_OD	Push- Pull / Open drain. Default value: 0. (0: Push- Pull; 1: Open drain)
I2_DRDY	Date Ready on DRDY/INT2. Default value 0. (0: Disable; 1: Enable)
I2_WTM	FIFO Watermark interrupt on DRDY/INT2. Default value: 0. (0: Disable; 1: Enable)
I2_ORun	FIFO Overrun interrupt on DRDY/INT2 Default value: 0. (0: Disable; 1: Enable)
I2_Empty	FIFO Empty interrupt on DRDY/INT2. Default value: 0. (0: Disable; 1: Enable)

7.5 CTRL_REG4 (23h)

Table 30. CTRL_REG4 register

BDU	BLE	FS1	FS0	-	ST1	ST0	SIM
-----	-----	-----	-----	---	-----	-----	-----

Table 31. CTRL_REG4 description

BDU	Block Data Update. Default value: 0 (0: continuous update; 1: output registers not updated until MSB and LSB reading)
BLE	Big/Little Endian Data Selection. Default value 0. (0: Data LSB @ lower address; 1: Data MSB @ lower address)
FS1-FS0	Full Scale selection. Default value: 00 (00: 250 dps; 01: 500 dps; 10: 2000 dps; 11: 2000 dps)
ST1-ST0	Self Test Enable. Default value: 00 (00: Self Test Disabled; Other: See Table)
SIM	SPI Serial Interface Mode selection. Default value: 0 (0: 4-wire interface; 1: 3-wire interface).

Table 32. Self test mode configuration

ST1	ST0	Self test mode
0	0	Normal mode
0	1	Self test 0 (+) ⁽¹⁾
1	0	--
1	1	Self test 1 (-) ⁽¹⁾

1. DST sign (absolute value in [Table 4](#))

7.6 CTRL_REG5 (24h)

Table 33. CTRL_REG5 register

BOOT	FIFO_EN	--	HPen	INT1_Sel1	INT1_Sel0	Out_Sel1	Out_Sel0
------	---------	----	------	-----------	-----------	----------	----------

Table 34. CTRL_REG5 description

BOOT	Reboot memory content. Default value: 0 (0: normal mode; 1: reboot memory content)
FIFO_EN	FIFO enable. Default value: 0 (0: FIFO disable; 1: FIFO Enable)
HPen	High Pass filter Enable. Default value: 0 (0: HPF disabled; 1: HPF enabled. See Figure 20)
INT1_Sel1- INT1_Sel0	INT1 selection configuration. Default value: 0 (See Figure 20)
Out_Sel1- Out_Sel0	Out selection configuration. Default value: 0 (See Figure 20)

Figure 19. INT1_Sel and Out_Sel configuration block diagram

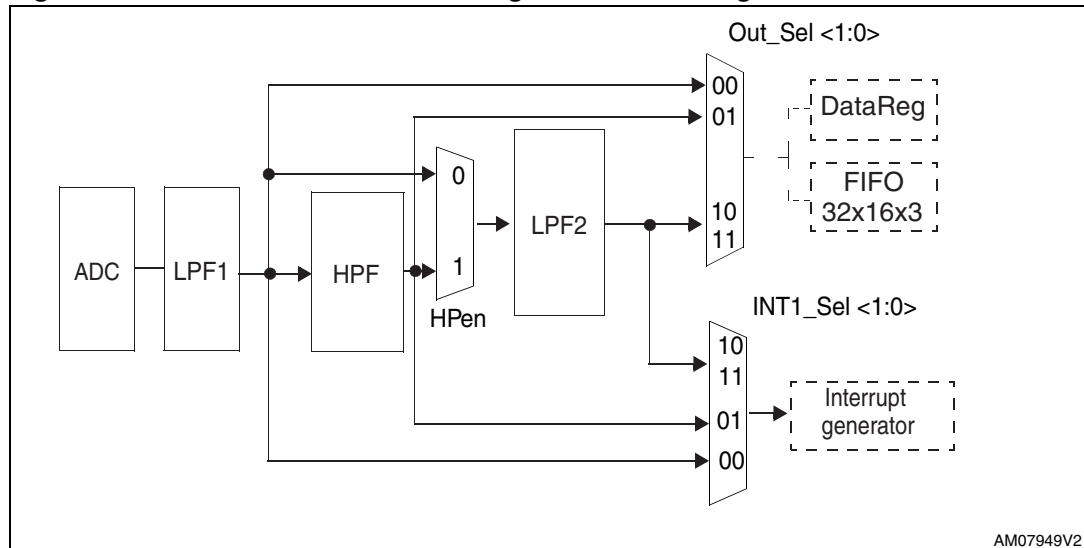

Table 35. Out_Sel configuration setting

Hpen	OUT_SEL1	OUT_SEL0	Description
x	0	0	Data in DataReg and FIFO are non-high-pass-filtered
x	0	1	Data in DataReg and FIFO are high-pass-filtered
0	1	x	Data in DataReg and FIFO are low-pass-filtered by LPF2
1	1	x	Data in DataReg and FIFO are high-pass and low-pass-filtered by LPF2

Table 36. INT_SEL configuration setting

Hpen	INT_SEL1	INT_SEL2	Description
x	0	0	Non-high-pass-filtered data are used for interrupt generation
x	0	1	High-pass-filtered data are used for interrupt generation
0	1	x	Low-pass-filtered data are used for interrupt generation
1	1	x	High-pass and low-pass-filtered data are used for interrupt generation

7.7 REFERENCE/DATACAPTURE (25h)

Table 37. REFERENCE register

Ref7	Ref6	Ref5	Ref4	Ref3	Ref2	Ref1	Ref0
------	------	------	------	------	------	------	------

Table 38. REFERENCE register description

Ref 7-Ref0	Reference value for Interrupt generation. Default value: 0
------------	--

7.8 OUT_TEMP (26h)

Table 39. OUT_TEMP register

Temp7	Temp6	Temp5	Temp4	Temp3	Temp2	Temp1	Temp0
-------	-------	-------	-------	-------	-------	-------	-------

Table 40. OUT_TEMP register description

Temp7-Temp0	Temperature data.
-------------	-------------------

7.9 STATUS_REG (27h)

Table 41. STATUS_REG register

ZYXOR	ZOR	YOR	XOR	ZYXDA	ZDA	YDA	XDA
-------	-----	-----	-----	-------	-----	-----	-----

Table 42. STATUS_REG description

ZYXOR	X, Y, Z -axis data overrun. Default value: 0 (0: no overrun has occurred; 1: new data has overwritten the previous one before it was read)
ZOR	Z axis data overrun. Default value: 0 (0: no overrun has occurred; 1: a new data for the Z-axis has overwritten the previous one)
YOR	Y axis data overrun. Default value: 0 (0: no overrun has occurred; 1: a new data for the Y-axis has overwritten the previous one)
XOR	X axis data overrun. Default value: 0 (0: no overrun has occurred; 1: a new data for the X-axis has overwritten the previous one)
ZYXDA	X, Y, Z -axis new data available. Default value: 0 (0: a new set of data is not yet available; 1: a new set of data is available)
ZDA	Z axis new data available. Default value: 0 (0: a new data for the Z-axis is not yet available; 1: a new data for the Z-axis is available)
YDA	Y axis new data available. Default value: 0 (0: a new data for the Y-axis is not yet available; 1: a new data for the Y-axis is available)
XDA	X axis new data available. Default value: 0 (0: a new data for the X-axis is not yet available; 1: a new data for the X-axis is available)

7.10 OUT_X_L (28h), OUT_X_H (29h)

X-axis angular rate data. The value is expressed as two's complement.

7.11 OUT_Y_L (2Ah), OUT_Y_H (2Bh)

Y-axis angular rate data. The value is expressed as two's complement.

7.12 OUT_Z_L (2Ch), OUT_Z_H (2Dh)

Z-axis angular rate data. The value is expressed as two's complement.

7.13 FIFO_CTRL_REG (2Eh)

Table 43. REFERENCE register

FM2	FM1	FM0	WTM4	WTM3	WTM2	WTM1	WTM0
-----	-----	-----	------	------	------	------	------

Table 44. REFERENCE register description

FM2-FM0	FIFO mode selection. Default value: 00 (see Table)
WTM4-WTM0	FIFO threshold. Watermark level setting

Table 45. FIFO mode configuration

FM2	FM1	FM0	FIFO mode
0	0	0	Bypass mode
0	0	1	FIFO mode
0	1	0	Stream mode
0	1	1	Stream-to-FIFO mode
1	0	0	Bypass-to-Stream mode

7.14 FIFO_SRC_REG (2Fh)

Table 46. FIFO_SRC register

WTM	OVRN	EMPTY	FSS4	FSS3	FSS2	FSS1	FSS0
-----	------	-------	------	------	------	------	------

Table 47. FIFO_SRC register description

WTM	Watermark status. (0: FIFO filling is lower than WTM level; 1: FIFO filling is equal or higher than WTM level)
OVRN	Overflow bit status. (0: FIFO is not completely filled; 1:FIFO is completely filled)

Table 47. FIFO_SRC register description (continued)

EMPTY	FIFO empty bit. (0: FIFO not empty; 1: FIFO empty)
FSS4-FSS1	FIFO stored data level

7.15 INT1_CFG (30h)

Table 48. INT1_CFG register

AND/OR	LIR	ZHIE	ZLIE	YHIE	YLIE	XHIE	XLIE
--------	-----	------	------	------	------	------	------

Table 49. INT1_CFG description

AND/OR	AND/OR combination of Interrupt events. Default value: 0 (0: OR combination of interrupt events 1: AND combination of interrupt events)
LIR	Latch Interrupt Request. Default value: 0 (0: interrupt request not latched; 1: interrupt request latched) Cleared by reading INT1_SRC reg.
ZHIE	Enable interrupt generation on Z high event. Default value: 0 (0: disable interrupt request; 1: enable interrupt request on measured accel. value higher than preset threshold)
ZLIE	Enable interrupt generation on Z low event. Default value: 0 (0: disable interrupt request; 1: enable interrupt request on measured accel. value lower than preset threshold)
YHIE	Enable interrupt generation on Y high event. Default value: 0 (0: disable interrupt request; 1: enable interrupt request on measured accel. value higher than preset threshold)
YLIE	Enable interrupt generation on Y low event. Default value: 0 (0: disable interrupt request; 1: enable interrupt request on measured accel. value lower than preset threshold)
XHIE	Enable interrupt generation on X high event. Default value: 0 (0: disable interrupt request; 1: enable interrupt request on measured accel. value higher than preset threshold)
XLIE	Enable interrupt generation on X low event. Default value: 0 (0: disable interrupt request; 1: enable interrupt request on measured accel. value lower than preset threshold)

Configuration register for Interrupt source.

7.16 INT1_SRC (31h)

Table 50. INT1_SRC register

0	IA	ZH	ZL	YH	YL	XH	XL
---	----	----	----	----	----	----	----

Table 51. INT1_SRC description

IA	Interrupt active. Default value: 0 (0: no interrupt has been generated; 1: one or more interrupts have been generated)
ZH	Z high. Default value: 0 (0: no interrupt, 1: Z High event has occurred)
ZL	Z low. Default value: 0 (0: no interrupt; 1: Z Low event has occurred)
YH	Y high. Default value: 0 (0: no interrupt, 1: Y High event has occurred)
YL	Y low. Default value: 0 (0: no interrupt, 1: Y Low event has occurred)
XH	X high. Default value: 0 (0: no interrupt, 1: X High event has occurred)
XL	X low. Default value: 0 (0: no interrupt, 1: X Low event has occurred)

Interrupt source register. Read only register.

Reading at this address clears INT1_SRC IA bit (and eventually the interrupt signal on INT1 pin) and allows the refreshment of data in the INT1_SRC register if the latched option was chosen.

7.17 INT1_THS_XH (32h)

Table 52. INT1_THS_XH register

-	THSX14	THSX13	THSX12	THSX11	THSX10	THSX9	THSX8
---	--------	--------	--------	--------	--------	-------	-------

Table 53. INT1_THS_XH description

THSX14 - THSX9	Interrupt threshold. Default value: 0000 0000
----------------	---

7.18 INT1_THS_XL (33h)

Table 54. INT1_THS_XL register

THSX7	THSX6	THSX5	THSX4	THSX3	THSX2	THSX1	THSX0
-------	-------	-------	-------	-------	-------	-------	-------

Table 55. INT1_THS_XL description

THSX7 - THSX0	Interrupt threshold. Default value: 0000 0000
---------------	---

7.19 INT1_THS_YH (34h)

Table 56. INT1_THS_YH register

-	THSY14	THSY13	THSY12	THSY11	THSY10	THSY9	THSY8
---	--------	--------	--------	--------	--------	-------	-------

Table 57. INT1_THS_YH description

THSY14 - THSY9	Interrupt threshold. Default value: 0000 0000
----------------	---

7.20 INT1_THS_YL (35h)

Table 58. INT1_THS_YL register

THSR7	THSY6	THSY5	THSY4	THSY3	THSY2	THSY1	THSY0
-------	-------	-------	-------	-------	-------	-------	-------

Table 59. INT1_THS_YL description

THSY7 - THSY0	Interrupt threshold. Default value: 0000 0000
---------------	---

7.21 INT1_THS_ZH (36h)

Table 60. INT1_THS_ZH register

-	THSZ14	THSZ13	THSZ12	THSZ11	THSZ10	THSZ9	THSZ8
---	--------	--------	--------	--------	--------	-------	-------

Table 61. INT1_THS_ZH description

THSZ14 - THSZ9	Interrupt threshold. Default value: 0000 0000
----------------	---

7.22 INT1_THS_ZL (37h)

Table 62. INT1_THS_ZL register

THSZ7	THSZ6	THSZ5	THSZ4	THSZ3	THSZ2	THSZ1	THSZ0
-------	-------	-------	-------	-------	-------	-------	-------

Table 63. INT1_THS_ZL description

THSZ7 - THSZ0	Interrupt threshold. Default value: 0000 0000
---------------	---

7.23 INT1_DURATION (38h)

Table 64. INT1_DURATION register

WAIT	D6	D5	D4	D3	D2	D1	D0
------	----	----	----	----	----	----	----

Table 65. INT1_DURATION description

WAIT	WAIT enable. Default value: 0 (0: disable; 1: enable)
D6 - D0	Duration value. Default value: 000 0000

D6 - D0 bits set the minimum duration of the Interrupt event to be recognized. Duration steps and maximum values depend on the ODR chosen.

WAIT bit has the following meaning:

Wait = '0': the interrupt falls immediately if signal crosses the selected threshold

Wait = '1': if signal crosses the selected threshold, the interrupt falls only after the duration has counted number of samples at the selected data rate, written into the duration counter register.

Figure 20. Wait disabled

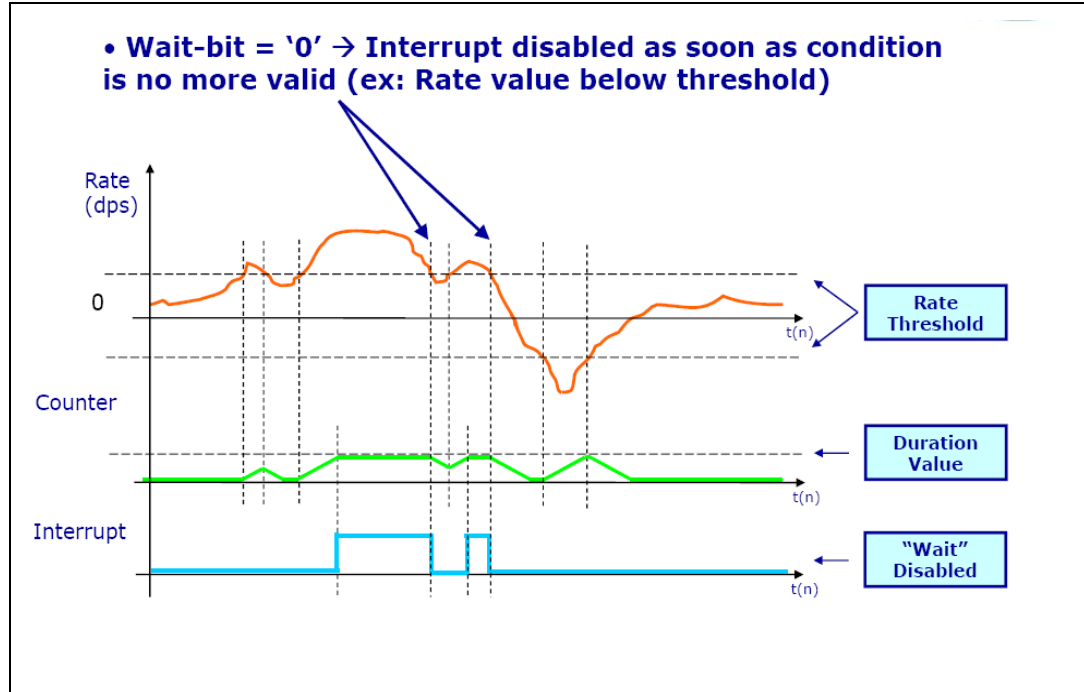
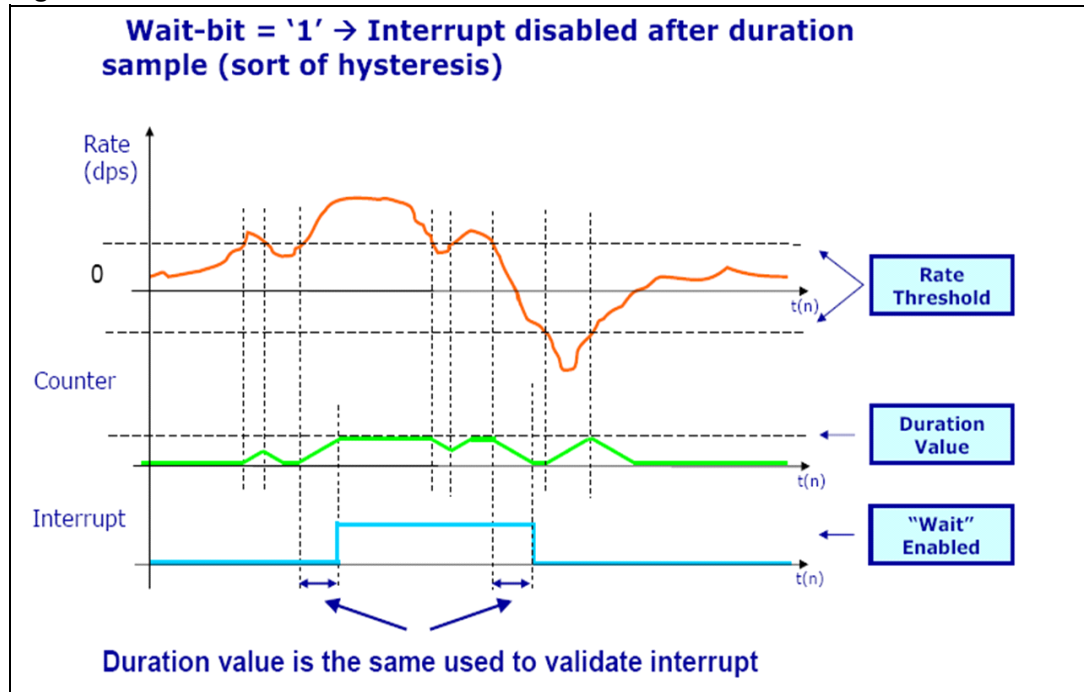

Figure 21. Wait enabled



8 Package information

In order to meet environmental requirements, ST offers these devices in different grades of ECOPACK® packages, depending on their level of environmental compliance. ECOPACK® specifications, grade definitions and product status are available at www.st.com. ECOPACK is an ST trademark.

Figure 22. LGA-16: mechanical data and package dimensions

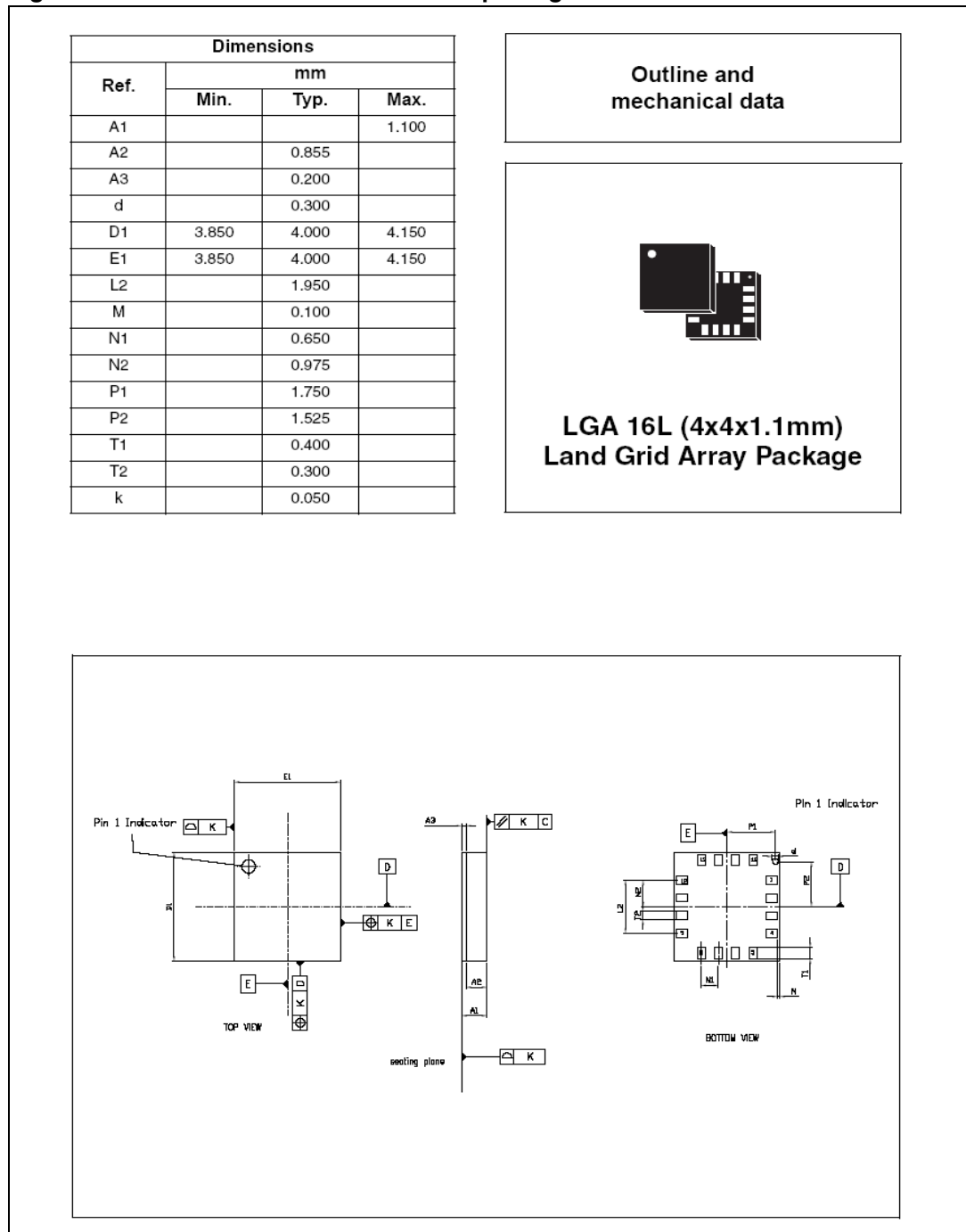

9 Revision history

Table 66. Document revision history

Date	Revision	Changes
01-Apr-2010	1	Initial release.
03-Sep-2010	2	Complete datasheet review.
22-Dec-2010	3	Inserted Section 6: Output register mapping and Section 7: Register description .

Please Read Carefully:

Information in this document is provided solely in connection with ST products. STMicroelectronics NV and its subsidiaries ("ST") reserve the right to make changes, corrections, modifications or improvements, to this document, and the products and services described herein at any time, without notice.

All ST products are sold pursuant to ST's terms and conditions of sale.

Purchasers are solely responsible for the choice, selection and use of the ST products and services described herein, and ST assumes no liability whatsoever relating to the choice, selection or use of the ST products and services described herein.

No license, express or implied, by estoppel or otherwise, to any intellectual property rights is granted under this document. If any part of this document refers to any third party products or services it shall not be deemed a license grant by ST for the use of such third party products or services, or any intellectual property contained therein or considered as a warranty covering the use in any manner whatsoever of such third party products or services or any intellectual property contained therein.

UNLESS OTHERWISE SET FORTH IN ST'S TERMS AND CONDITIONS OF SALE ST DISCLAIMS ANY EXPRESS OR IMPLIED WARRANTY WITH RESPECT TO THE USE AND/OR SALE OF ST PRODUCTS INCLUDING WITHOUT LIMITATION IMPLIED WARRANTIES OF MERCHANTABILITY, FITNESS FOR A PARTICULAR PURPOSE (AND THEIR EQUIVALENTS UNDER THE LAWS OF ANY JURISDICTION), OR INFRINGEMENT OF ANY PATENT, COPYRIGHT OR OTHER INTELLECTUAL PROPERTY RIGHT.

UNLESS EXPRESSLY APPROVED IN WRITING BY AN AUTHORIZED ST REPRESENTATIVE, ST PRODUCTS ARE NOT RECOMMENDED, AUTHORIZED OR WARRANTED FOR USE IN MILITARY, AIR CRAFT, SPACE, LIFE SAVING, OR LIFE SUSTAINING APPLICATIONS, NOR IN PRODUCTS OR SYSTEMS WHERE FAILURE OR MALFUNCTION MAY RESULT IN PERSONAL INJURY, DEATH, OR SEVERE PROPERTY OR ENVIRONMENTAL DAMAGE. ST PRODUCTS WHICH ARE NOT SPECIFIED AS "AUTOMOTIVE GRADE" MAY ONLY BE USED IN AUTOMOTIVE APPLICATIONS AT USER'S OWN RISK.

Resale of ST products with provisions different from the statements and/or technical features set forth in this document shall immediately void any warranty granted by ST for the ST product or service described herein and shall not create or extend in any manner whatsoever, any liability of ST.

ST and the ST logo are trademarks or registered trademarks of ST in various countries.

Information in this document supersedes and replaces all information previously supplied.

The ST logo is a registered trademark of STMicroelectronics. All other names are the property of their respective owners.

© 2010 STMicroelectronics - All rights reserved

STMicroelectronics group of companies

Australia - Belgium - Brazil - Canada - China - Czech Republic - Finland - France - Germany - Hong Kong - India - Israel - Italy - Japan - Malaysia - Malta - Morocco - Philippines - Singapore - Spain - Sweden - Switzerland - United Kingdom - United States of America

www.st.com