

REVISIONS																	
LTR	DESCRIPTION	DATE (YR-MO-DA)	APPROVED														
A	Update drawing to current requirements. Editorial changes throughout. - gap	07-08-06	Robert M. Heber														
The original first sheet of this drawing has been replaced.																	
REV																	
SHEET																	
REV																	
SHEET																	
REV STATUS	REV	A	A	A	A	A	A	A	A	A	A	A	A	A	A		
OF SHEETS	SHEET	1	2	3	4	5	6	7	8	9	10	11	12				
PMIC N/A	PREPARED BY Tim H. Noh					<b>DEFENSE SUPPLY CENTER COLUMBUS</b> <b>COLUMBUS, OHIO 43218-3990</b> <a href="http://www.dsccl.dla.mil">http://www.dsccl.dla.mil</a>											
<b>STANDARD MICROCIRCUIT DRAWING</b>  THIS DRAWING IS AVAILABLE FOR USE BY ALL DEPARTMENTS AND AGENCIES OF THE DEPARTMENT OF DEFENSE  AMSC N/A	CHECKED BY Tim H. Noh																
	APPROVED BY William K. Heckman																
	DRAWING APPROVAL DATE 89-08-11																
	REVISION LEVEL A																
					SIZE A	CAGE CODE <b>67268</b>	<b>5962-89723</b>										
					SHEET 1 OF 12												

1. SCOPE

1.1 Scope. This drawing describes device requirements for MIL-STD-883 compliant, non-JAN class level B microcircuits in accordance with MIL-PRF-38535, appendix A.

1.2 Part or Identifying Number (PIN). The complete PIN is as shown in the following example:

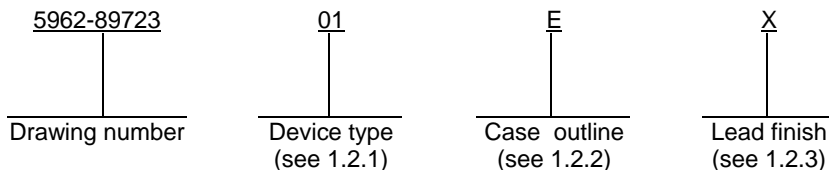

1.2.1 Device type(s). The device type(s) identify the circuit function as follows:

<u>Device type</u>	<u>Generic number</u>	<u>Circuit function</u>
01	54F259	8-bit addressable latch

1.2.2 Case outline(s). The case outline(s) are as designated in MIL-STD-1835 and as follows:

<u>Outline letter</u>	<u>Descriptive designator</u>	<u>Terminals</u>	<u>Package style</u>
E	GDIP1-T16 or CDIP2-T16	16	Dual-in-line
F	GDFP2-F16 or CDFP3-F16	16	Flat pack
2	CQCC1-N20	20	Leadless square chip carrier

1.2.3 Lead finish. The lead finish is as specified in MIL-PRF-38535, appendix A.

1.3 Absolute maximum ratings.

Supply voltage range .....	-0.5 V dc minimum to +7.0 V dc maximum
Input voltage range .....	-0.5 V dc minimum to +7.0 V dc maximum
Input current range .....	-30 mA to +5.0 mA
Voltage applied to output in high output state range .....	-0.5 V dc to +V <sub>CC</sub>
Current applied to output in low output state .....	40 mA
Storage temperature range .....	-65°C to +150°C
Maximum power dissipation (P <sub>D</sub> ) <sup>1/</sup> .....	413 mW
Lead temperature (soldering, 10 seconds) .....	+300°C
Thermal resistance, junction-to-case (θ <sub>JC</sub> ) .....	See MIL-STD-1835
Junction temperature (T <sub>J</sub> ) .....	+175°C

<sup>1/</sup> Must withstand the added PD due to short circuit test; e.g., I<sub>OS</sub>.

<b>STANDARD MICROCIRCUIT DRAWING</b> DEFENSE SUPPLY CENTER COLUMBUS COLUMBUS, OHIO 43218-3990	SIZE <b>A</b>		<b>5962-89723</b>
		REVISION LEVEL A	SHEET <b>2</b>

1.4 Recommended operating conditions.

Supply voltage range ( $V_{CC}$ ) .....	+4.5 V dc minimum to +5.5 V dc maximum
Minimum high level input voltage ( $V_{IH}$ ) .....	2.0 V dc
Maximum low level input voltage ( $V_{IL}$ ) .....	0.8 V dc
Case operating temperature range ( $T_C$ ) .....	-55°C to +125°C
Minimum setup time ( $t_s$ )	
D to $\bar{E}$ , high:	
$T_C = +25^\circ\text{C}$ .....	3.0 ns
$T_C = -55^\circ\text{C}, +125^\circ\text{C}$ .....	3.0 ns
D to $\bar{E}$ , low:	
$T_C = +25^\circ\text{C}$ .....	6.5 ns
$T_C = -55^\circ\text{C}, +125^\circ\text{C}$ .....	8.0 ns
An to $\bar{E}$ : 1/	
$T_C = +25^\circ\text{C}$ .....	2.0 ns
$T_C = -55^\circ\text{C}, +125^\circ\text{C}$ .....	2.0 ns
Minimum hold time ( $t_h$ )	
D to $\bar{E}$ :	
$T_C = +25^\circ\text{C}$ .....	0 ns
$T_C = -55^\circ\text{C}, +125^\circ\text{C}$ .....	0 ns
An to $\bar{E}$ : 2/	
$T_C = +25^\circ\text{C}$ .....	0 ns
$T_C = -55^\circ\text{C}, +125^\circ\text{C}$ .....	1.0 ns
Minimum pulse width ( $t_w$ )	
$\bar{E}$ :	
$T_C = +25^\circ\text{C}$ .....	7.5 ns
$T_C = -55^\circ\text{C}, +125^\circ\text{C}$ .....	8.0 ns
MR:	
$T_C = +25^\circ\text{C}$ .....	3.0 ns
$T_C = -55^\circ\text{C}, +125^\circ\text{C}$ .....	4.0 ns

1/ The address to enable setup time is the time before high to low enable transition that the address must be stable so that the correct latch is addressed and the other latches are not affected.

2/ The address to enable hold time is the time after the low to high enable transition that the address must be stable so that the correct latch is addressed and the other latches are not affected.

<b>STANDARD MICROCIRCUIT DRAWING</b> DEFENSE SUPPLY CENTER COLUMBUS COLUMBUS, OHIO 43218-3990	SIZE <b>A</b>		<b>5962-89723</b>
		REVISION LEVEL A	SHEET <b>3</b>

## 2. APPLICABLE DOCUMENTS

2.1 Government specification, standards, and handbooks. The following specification, standards, and handbooks form a part of this drawing to the extent specified herein. Unless otherwise specified, the issues of these documents are those cited in the solicitation or contract.

### DEPARTMENT OF DEFENSE SPECIFICATION

MIL-PRF-38535 - Integrated Circuits, Manufacturing, General Specification for.

### DEPARTMENT OF DEFENSE STANDARDS

MIL-STD-883 - Test Method Standard Microcircuits.  
MIL-STD-1835 - Interface Standard Electronic Component Case Outlines.

### DEPARTMENT OF DEFENSE HANDBOOKS

MIL-HDBK-103 - List of Standard Microcircuit Drawings.  
MIL-HDBK-780 - Standard Microcircuit Drawings.

(Copies of these documents are available online at <http://assist.daps.dla.mil/quicksearch/> or [www.dodssp.daps.mil](http://www.dodssp.daps.mil) or from the Standardization Document Order Desk, 700 Robbins Avenue, Building 4D, Philadelphia, PA 19111-5094.)

2.2 Order of precedence. In the event of a conflict between the text of this drawing and the references cited herein, the text of this drawing takes precedence. Nothing in this document, however, supersedes applicable laws and regulations unless a specific exemption has been obtained.

## 3. REQUIREMENTS

3.1 Item requirements. The individual item requirements shall be in accordance with MIL-PRF-38535, appendix A for non-JAN class level B devices and as specified herein. Product built to this drawing that is produced by a Qualified Manufacturer Listing (QML) certified and qualified manufacturer or a manufacturer who has been granted transitional certification to MIL-PRF-38535 may be processed as QML product in accordance with the manufacturers approved program plan and qualifying activity approval in accordance with MIL-PRF-38535. This QML flow as documented in the Quality Management (QM) plan may make modifications to the requirements herein. These modifications shall not affect form, fit, or function of the device. These modifications shall not affect the PIN as described herein. A "Q" or "QML" certification mark in accordance with MIL-PRF-38535 is required to identify when the QML flow option is used.

3.2 Design, construction, and physical dimensions. The design, construction, and physical dimensions shall be as specified in MIL-PRF-38535, appendix A and herein.

3.2.1 Case outlines. The case outlines shall be in accordance with 1.2.2 herein.

3.2.2 Terminal connections. The terminal connections shall be as specified on figure 1.

3.2.3 Truth table. The truth table shall be as specified on figure 2.

3.2.4 Logic diagram. The logic diagram shall be as specified on figure 3.

3.2.5 Test circuit and switching waveforms. The test circuit and switching waveforms shall be as specified on figure 4.

<b>STANDARD MICROCIRCUIT DRAWING</b> DEFENSE SUPPLY CENTER COLUMBUS COLUMBUS, OHIO 43218-3990	SIZE <b>A</b>		<b>5962-89723</b>
		REVISION LEVEL A	SHEET <b>4</b>

3.3 Electrical performance characteristics. Unless otherwise specified herein, the electrical performance characteristics are as specified in table I and shall apply over the full (case or ambient) operating temperature range.

3.4 Electrical test requirements. The electrical test requirements shall be the subgroups specified in table II. The electrical tests for each subgroup are described in table I.

3.5 Marking. Marking shall be in accordance with MIL-PRF-38535, appendix A. The part shall be marked with the PIN listed in 1.2 herein. In addition, the manufacturer's PIN may also be marked. For packages where marking of the entire SMD PIN number is not feasible due to space limitations, the manufacturer has the option of not marking the "5962-" on the device.

3.5.1 Certification/compliance mark. A compliance indicator "C" shall be marked on all non-JAN devices built in compliance to MIL-PRF-38535, appendix A. The compliance indicator "C" shall be replaced with a "Q" or "QML" certification mark in accordance with MIL-PRF-38535 to identify when the QML flow option is used.

3.6 Certificate of compliance. A certificate of compliance shall be required from a manufacturer in order to be listed as an approved source of supply in MIL-HDBK-103 (see 6.6 herein). The certificate of compliance submitted to DSCC-VA prior to listing as an approved source of supply shall affirm that the manufacturer's product meets the requirements of MIL-PRF-38535, appendix A and the requirements herein.

3.7 Certificate of conformance. A certificate of conformance as required in MIL-PRF-38535, appendix A shall be provided with each lot of microcircuits delivered to this drawing.

3.8 Notification of change. Notification of change to DSCC-VA shall be required for any change that affects this drawing.

3.9 Verification and review. DSCC, DSCC's agent, and the acquiring activity retain the option to review the manufacturer's facility and applicable required documentation. Offshore documentation shall be made available onshore at the option of the reviewer.

#### 4. VERIFICATION

4.1 Sampling and inspection. Sampling and inspection procedures shall be in accordance with MIL-PRF-38535, appendix A.

4.2 Screening. Screening shall be in accordance with method 5004 of MIL-STD-883, and shall be conducted on all devices prior to quality conformance inspection. The following additional criteria shall apply:

a. Burn-in test, method 1015 of MIL-STD-883.

(1) Test condition A, B, C, or D. The test circuit shall be maintained by the manufacturer under document revision level control and shall be made available to the preparing or acquiring activity upon request. The test circuit shall specify the inputs, outputs, biases, and power dissipation, as applicable, in accordance with the intent specified in method 1015 of MIL-STD-883.

(2)  $T_A = +125^{\circ}\text{C}$ , minimum.

b. Interim and final electrical test parameters shall be as specified in table II herein, except interim electrical parameter tests prior to burn-in are optional at the discretion of the manufacturer.

<b>STANDARD MICROCIRCUIT DRAWING</b> DEFENSE SUPPLY CENTER COLUMBUS COLUMBUS, OHIO 43218-3990	SIZE <b>A</b>		<b>5962-89723</b>
		REVISION LEVEL A	SHEET <b>5</b>

TABLE I. Electrical performance characteristics.

Test	Symbol	Conditions -55°C ≤ T <sub>C</sub> ≤ +125°C unless otherwise specified		Group A subgroups	Limits		Unit
					Min	Max	
High level output voltage	V <sub>OH</sub>	V <sub>CC</sub> = 4.5 V, V <sub>IL</sub> = 0.8 V, V <sub>IH</sub> = 2.0 V, I <sub>OH</sub> = -1.0 mA		1, 2, 3	2.5		V
Low level output voltage	V <sub>OL</sub>	V <sub>CC</sub> = 4.5 V, V <sub>IL</sub> = 0.8 V, V <sub>IH</sub> = 2.0 V, I <sub>OL</sub> = 20 mA		1, 2, 3		0.5	V
Input clamp voltage	V <sub>IC</sub>	V <sub>CC</sub> = 4.5 V, I <sub>IN</sub> = -18 mA		1, 2, 3		-1.2	V
High level input current	I <sub>IH1</sub>	V <sub>CC</sub> = 5.5 V, V <sub>IN</sub> = 2.7 V		1, 2, 3		20	μA
	I <sub>IH2</sub>	V <sub>CC</sub> = 5.5 V, V <sub>IN</sub> = 7.0 V		1, 2, 3		100	
Low level input current	I <sub>IL</sub>	V <sub>CC</sub> = 5.5 V, V <sub>IN</sub> = 0.5 V		1, 2, 3		-0.6	mA
Short circuit output current	I <sub>OS</sub>	V <sub>CC</sub> = 5.5 V <sup>1/</sup>		1, 2, 3	-60	-150	mA
Supply current	I <sub>CCH</sub>	V <sub>CC</sub> = 5.5 V		1, 2, 3		46	mA
	I <sub>CCL</sub>			1, 2, 3		75	
Functional test		See 4.3.1c					
Propagation delay time, D to Qn	t <sub>PLH1</sub>	R <sub>L</sub> = 500 Ω, C <sub>L</sub> = 50 pF	V <sub>CC</sub> = 5.0 V	9	4.0	9.0	ns
			V <sub>CC</sub> = 4.5 V to 5.5 V	10, 11	4.0	13.0	
	See figure 4		V <sub>CC</sub> = 5.0 V	9	3.0	7.0	
			V <sub>CC</sub> = 4.5 V to 5.5 V	10, 11	2.5	11.0	
Propagation delay time, E to Qn	t <sub>PLH2</sub>	V <sub>CC</sub> = 5.0 V	9	4.5	10.5	ns	
		V <sub>CC</sub> = 4.5 V to 5.5 V	10, 11	4.5	14.0		
	t <sub>PHL2</sub>	V <sub>CC</sub> = 5.0 V	9	3.0	7.0		
		V <sub>CC</sub> = 4.5 V to 5.5 V	10, 11	3.0	11.0		
Propagation delay time, An to Qn	t <sub>PLH3</sub>	V <sub>CC</sub> = 5.0 V	9	5.0	14.0	ns	
		V <sub>CC</sub> = 4.5 V to 5.5 V	10, 11	5.0	14.5		
	t <sub>PHL3</sub>	V <sub>CC</sub> = 5.0 V	9	4.0	9.5		
		V <sub>CC</sub> = 4.5 V to 5.5 V	10, 11	4.0	12.0		
Propagation delay time, MR to Qn	t <sub>PHL4</sub>	V <sub>CC</sub> = 5.0 V	9	5.0	9.0	ns	
		V <sub>CC</sub> = 4.5 V to 5.5 V	10, 11	5.0	14.0		

<sup>1/</sup> Not more than one output should be shorted at one time and the duration of the short circuit condition shall not exceed 1 second.

<b>STANDARD MICROCIRCUIT DRAWING</b> DEFENSE SUPPLY CENTER COLUMBUS COLUMBUS, OHIO 43218-3990	SIZE <b>A</b>		<b>5962-89723</b>
		REVISION LEVEL A	SHEET <b>6</b>

Device type	01	
Case outlines	E and F	2
Terminal number	Terminal symbol	
1	A0	NC
2	A1	A0
3	A2	A1
4	Q0	A2
5	Q1	Q0
6	Q2	NC
7	Q3	Q1
8	GND	Q2
9	Q4	Q3
10	Q5	GND
11	Q6	NC
12	Q7	Q4
13	D	Q5
14	$\bar{E}$	Q6
15	$\overline{MR}$	Q7
16	$V_{CC}$	NC
17		D
18		$\bar{E}$
19		$\overline{MR}$
20		$V_{CC}$

NC = No connection

FIGURE 1. Terminal connections.

<b>STANDARD MICROCIRCUIT DRAWING</b> DEFENSE SUPPLY CENTER COLUMBUS COLUMBUS, OHIO 43218-3990	SIZE <b>A</b>		<b>5962-89723</b>
		REVISION LEVEL A	SHEET <b>7</b>

Operating mode	Inputs						Outputs							
	$\overline{MR}$	$\overline{E}$	D	A0	A1	A2	Q0	Q1	Q2	Q3	Q4	Q5	Q6	Q7
Master reset	L	H	X	X	X	X	L	L	L	L	L	L	L	L
Demultiplex (active HIGH decoder when D = H)	L	L	d	L	L	L	Q=d	L	L	L	L	L	L	L
	L	L	d	H	L	L	L	Q=d	L	L	L	L	L	L
	L	L	d	L	H	L	L	L	Q=d	L	L	L	L	L
	L	L	d	H	H	L	L	L	L	Q=d	L	L	L	L
	L	L	d	L	L	H	L	L	L	L	Q=d	L	L	L
	L	L	d	H	L	H	L	L	L	L	L	Q=d	L	L
	L	L	d	L	H	H	L	L	L	L	L	L	Q=d	L
	L	L	d	H	H	H	L	L	L	L	L	L	L	Q=d
Store (do nothing)	H	H	X	X	X	X	q0	q1	q2	q3	q4	q5	q6	q7
Addressable latch	H	L	d	L	L	L	Q=d	q1	q2	q3	q4	q5	q6	q7
	H	L	d	H	L	L	q0	Q=d	q2	q3	q4	q5	q6	q7
	H	L	d	L	H	L	q0	q1	Q=d	q3	q4	q5	q6	q7
	H	L	d	H	H	L	q0	q1	q2	Q=d	q4	q5	q6	q7
	H	L	d	L	L	H	q0	q1	q2	q3	Q=d	q5	q6	q7
	H	L	d	H	L	H	q0	q1	q2	q3	q4	Q=d	q6	q7
	H	L	d	L	H	H	q0	q1	q2	q3	q4	q5	Q=d	q7
	H	L	d	H	H	H	q0	q1	q2	q3	q4	q5	q6	Q=d

- H = High voltage level steady state.  
 L = Low voltage level steady state.  
 X = Irrelevant.  
 d = High or low data one setup time prior to the low to high enable transition.  
 q = Lower case letters indicate the state of the referenced output established during the last cycle in which it was addressed or cleared.

FIGURE 2. Truth table.

<b>STANDARD MICROCIRCUIT DRAWING</b> DEFENSE SUPPLY CENTER COLUMBUS COLUMBUS, OHIO 43218-3990	SIZE <b>A</b>		<b>5962-89723</b>
		REVISION LEVEL A	SHEET <b>8</b>



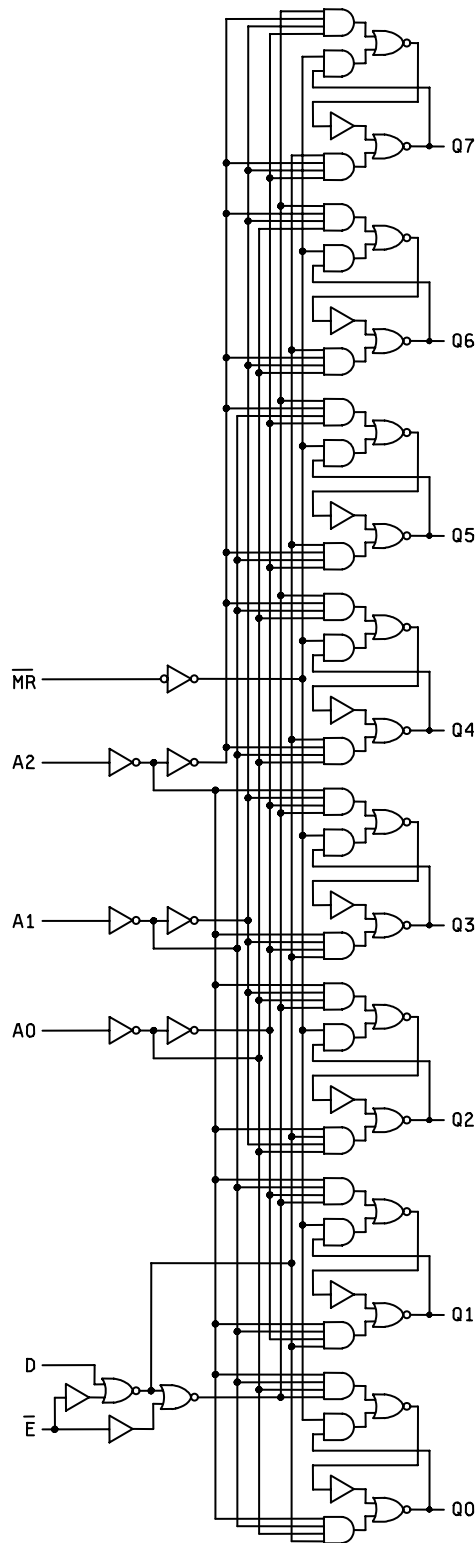
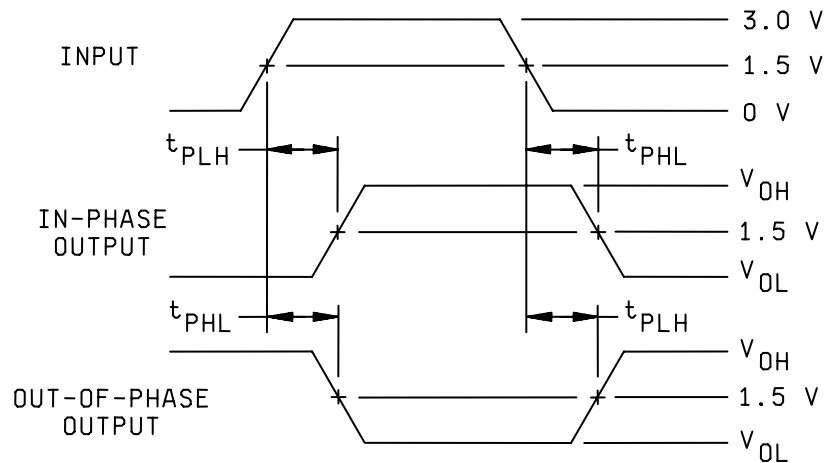
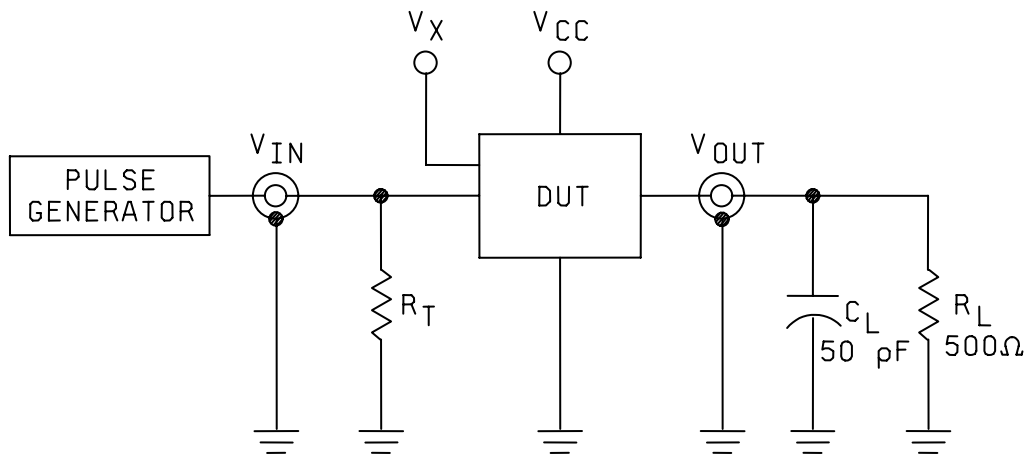

FIGURE 3. Logic diagram.

<b>STANDARD MICROCIRCUIT DRAWING</b> DEFENSE SUPPLY CENTER COLUMBUS COLUMBUS, OHIO 43218-3990	SIZE <b>A</b>		<b>5962-89723</b>
		REVISION LEVEL A	SHEET <b>9</b>



NOTES:

1.  $C_L$  includes jig and probe capacitance.
2.  $R_T$  = Termination resistance should be equal to  $Z_{OUT}$  of pulse generator.
3.  $V_X$  = Unclocked pins must be held at  $\leq 0.8$  V,  $\geq 2.7$  V or open.
4. All input pulses have the following characteristics: PRR = 1 MHz,  $t_r = t_f = 2.5$  ns, duty cycle = 50 percent.

FIGURE 4. Test circuit and switching waveforms.

<b>STANDARD MICROCIRCUIT DRAWING</b> DEFENSE SUPPLY CENTER COLUMBUS COLUMBUS, OHIO 43218-3990	SIZE <b>A</b>		<b>5962-89723</b>
		REVISION LEVEL <b>A</b>	SHEET <b>10</b>

TABLE II. Electrical test requirements.

MIL-STD-883 test requirements	Subgroups (in accordance with MIL-STD-883, method 5005, table I)
Interim electrical parameters (method 5004)	---
Final electrical test parameters (method 5004)	1*, 2, 3, 7, 8, 9, 10, 11
Group A test requirements (method 5005)	1, 2, 3, 7, 8, 9, 10, 11
Groups C and D end-point electrical parameters (method 5005)	1, 2, 3

\* PDA applies to subgroup 1.

4.3 Quality conformance inspection. Quality conformance inspection shall be in accordance with method 5005 of MIL-STD-883 including groups A, B, C, and D inspections. The following additional criteria shall apply.

4.3.1 Group A inspection.

- a. Tests shall be as specified in table II herein.
- b. Subgroups 4, 5, and 6 in table I, method 5005 of MIL-STD-883 shall be omitted.
- c. Subgroups 7 and 8 shall include verification of the truth table.

4.3.2 Groups C and D inspections.

- a. End-point electrical parameters shall be as specified in table II herein.
- b. Steady-state life test conditions, method 1005 of MIL-STD-883.
  - (1) Test condition A, B, C, or D. The test circuit shall be maintained by the manufacturer under document revision level control and shall be made available to the preparing or acquiring activity upon request. The test circuit shall specify the inputs, outputs, biases, and power dissipation, as applicable, in accordance with the intent specified in method 1005 of MIL-STD-883.
  - (2)  $T_A = +125^\circ\text{C}$ , minimum.
  - (3) Test duration: 1,000 hours, except as permitted by method 1005 of MIL-STD-883.

<b>STANDARD MICROCIRCUIT DRAWING</b> DEFENSE SUPPLY CENTER COLUMBUS COLUMBUS, OHIO 43218-3990	SIZE <b>A</b>		<b>5962-89723</b>
		REVISION LEVEL A	SHEET <b>11</b>

5. PACKAGING

5.1 Packaging requirements. The requirements for packaging shall be in accordance with MIL-PRF-38535, appendix A.

6. NOTES

6.1 Intended use. Microcircuits conforming to this drawing are intended for use for Government microcircuit applications (original equipment), design applications, and logistics purposes.

6.2 Replaceability. Microcircuits covered by this drawing will replace the same generic device covered by a contractor-prepared specification or drawing.

6.3 Configuration control of SMD's. All proposed changes to existing SMD's will be coordinated with the users of record for the individual documents. This coordination will be accomplished using DD Form 1692, Engineering Change Proposal.

6.4 Record of users. Military and industrial users shall inform Defense Supply Center Columbus (DSCC) when a system application requires configuration control and the applicable SMD. DSCC will maintain a record of users and this list will be used for coordination and distribution of changes to the drawings. Users of drawings covering microelectronics devices (FSC 5962) should contact DSCC-VA, telephone (614) 692-0544.

6.5 Comments. Comments on this drawing should be directed to DSCC-VA, Columbus, Ohio 43218-3990, or telephone (614) 692-0547.

6.6 Approved sources of supply. Approved sources of supply are listed in MIL-HDBK-103. The vendors listed in MIL-HDBK-103 have agreed to this drawing and a certificate of compliance (see 3.6 herein) has been submitted to and accepted by DSCC-VA.

<b>STANDARD MICROCIRCUIT DRAWING</b> DEFENSE SUPPLY CENTER COLUMBUS COLUMBUS, OHIO 43218-3990	SIZE <b>A</b>		<b>5962-89723</b>
		REVISION LEVEL A	SHEET <b>12</b>

STANDARD MICROCIRCUIT DRAWING BULLETIN

DATE: 07-08-06

Approved sources of supply for SMD 5962-89723 are listed below for immediate acquisition information only and shall be added to MIL-HDBK-103 and QML-38535 during the next revision. MIL-HDBK-103 and QML-38535 will be revised to include the addition or deletion of sources. The vendors listed below have agreed to this drawing and a certificate of compliance has been submitted to and accepted by DSCC-VA. This information bulletin is superseded by the next dated revision of MIL-HDBK-103 and QML-38535. DSCC maintains an online database of all current sources of supply at <http://www.dsccl.dla.mil/Programs/Smcr/>.

Standard microcircuit drawing PIN <u>1/</u>	Vendor CAGE number <u>3/</u>	Vendor similar PIN <u>2/</u>
5962-8972301EA	<u>3/</u>	54F259/BEA
5962-8972301FA	<u>3/</u>	54F259/BFA
5962-89723012A	<u>3/</u>	54F259/B2A

- 1/ The lead finish shown for each PIN representing a hermetic package is the most readily available from the manufacturer listed for that part. If the desired lead finish is not listed contact the vendor to determine its availability.
- 2/ Caution. Do not use this number for item acquisition. Items acquired to this number may not satisfy the performance requirements of this drawing.
- 3/ Not available from an approved source of supply. The last known source of supply is listed below.

Vendor CAGE number

18324

Vendor name and address

Signetics Company  
4130 South Market Court  
Sacramento, CA 95834

The information contained herein is disseminated for convenience only and the Government assumes no liability whatsoever for any inaccuracies in the information bulletin.