

Dec.1.2021 Copyright 2021 HIROSE ELECTRIC CO., LTD. All Rights Reserved.
In case of consideration for using Automotive equipment / device which demand high reliability, kindly contact our sales window correspondents.

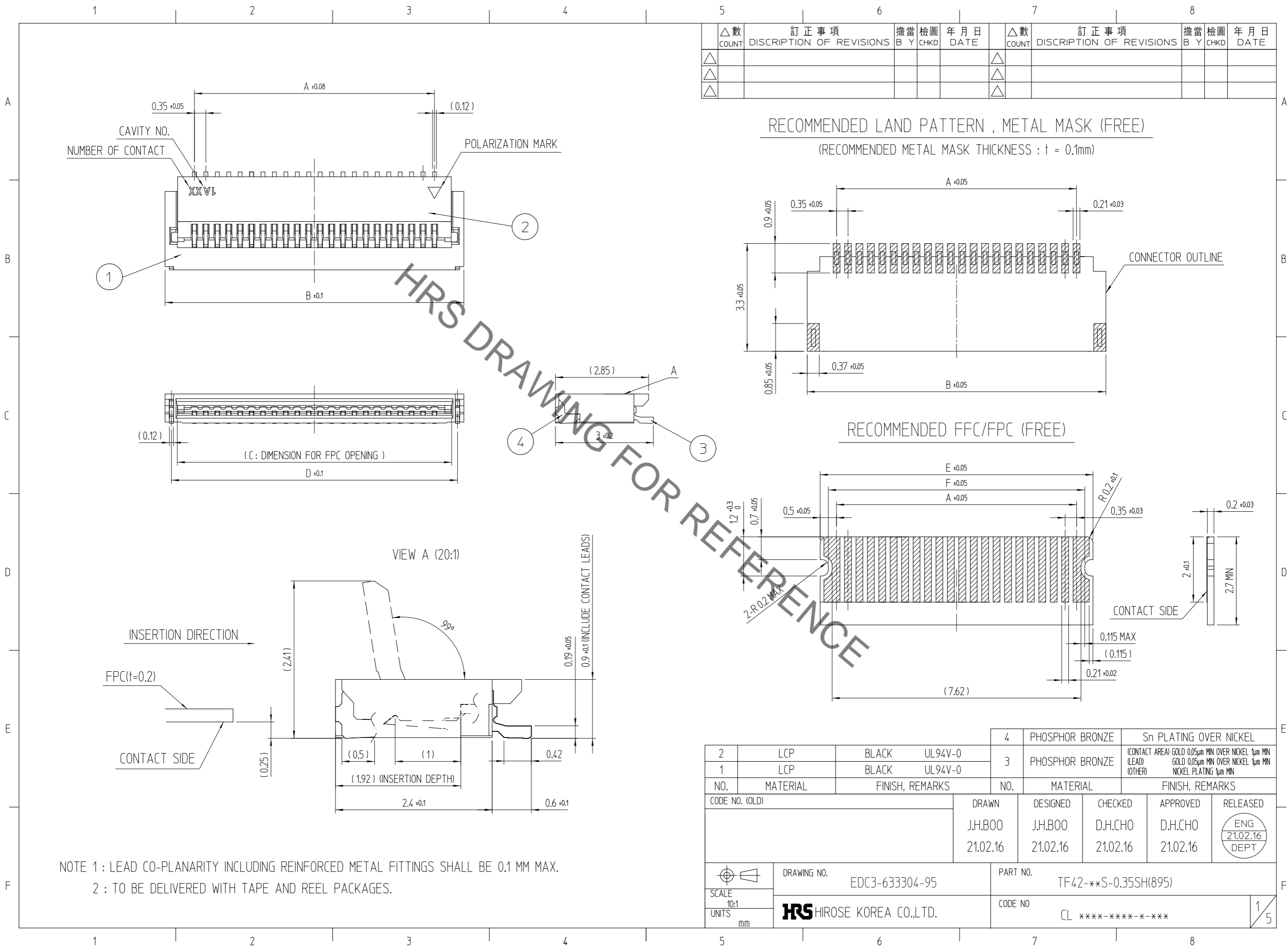

△數 COUNT	訂正事項 DISCRIPTION OF REVISIONS	擔當 B Y	檢圖 CHKD	年月日 DATE	△數 COUNT	訂正事項 DISCRIPTION OF REVISIONS	擔當 B Y	檢圖 CHKD	年月日 DATE
△					△				
△					△				
△					△				

HRS DRAWING FOR REFERENCE

NOTE 1 : LEAD CO-PLANARITY INCLUDING REINFORCED METAL FITTINGS SHALL BE 0.1 MM MAX.
2 : TO BE DELIVERED WITH TAPE AND REEL PACKAGES.

2	LCP	BLACK	UL94V-0	4	PHOSPHOR BRONZE	Sn PLATING OVER NICKEL			
1	LCP	BLACK	UL94V-0	3	PHOSPHOR BRONZE	(CONTACT AREA) GOLD 0.05µm MIN OVER NICKEL 1µm MIN (LEAD) GOLD 0.05µm MIN OVER NICKEL 1µm MIN (OTHER) NICKEL PLATING 1µm MIN			
NO.	MATERIAL	FINISH, REMARKS		NO.	MATERIAL	FINISH, REMARKS			
CODE NO. (OLD)				DRAWN		DESIGNED	CHECKED	APPROVED	RELEASED
				J.H.BOO		J.H.BOO	D.H.CHO	D.H.CHO	ENG 21.02.16 DEPT
				21.02.16		21.02.16	21.02.16	21.02.16	
DRAWING NO.		EDC3-633304-95		PART NO.		TF42-**S-0.35SH(895)			
SCALE		10:1		CODE NO		CL ****-****-*-***			
UNITS		mm		HRS HIROSE KOREA CO.,LTD.					
						1/5			

Dec.1.2021 Copyright 2021 HIROSE ELECTRIC CO., LTD. All Rights Reserved.
In case of consideration for using Automotive equipment / device which demand high reliability, kindly contact our sales window correspondents.

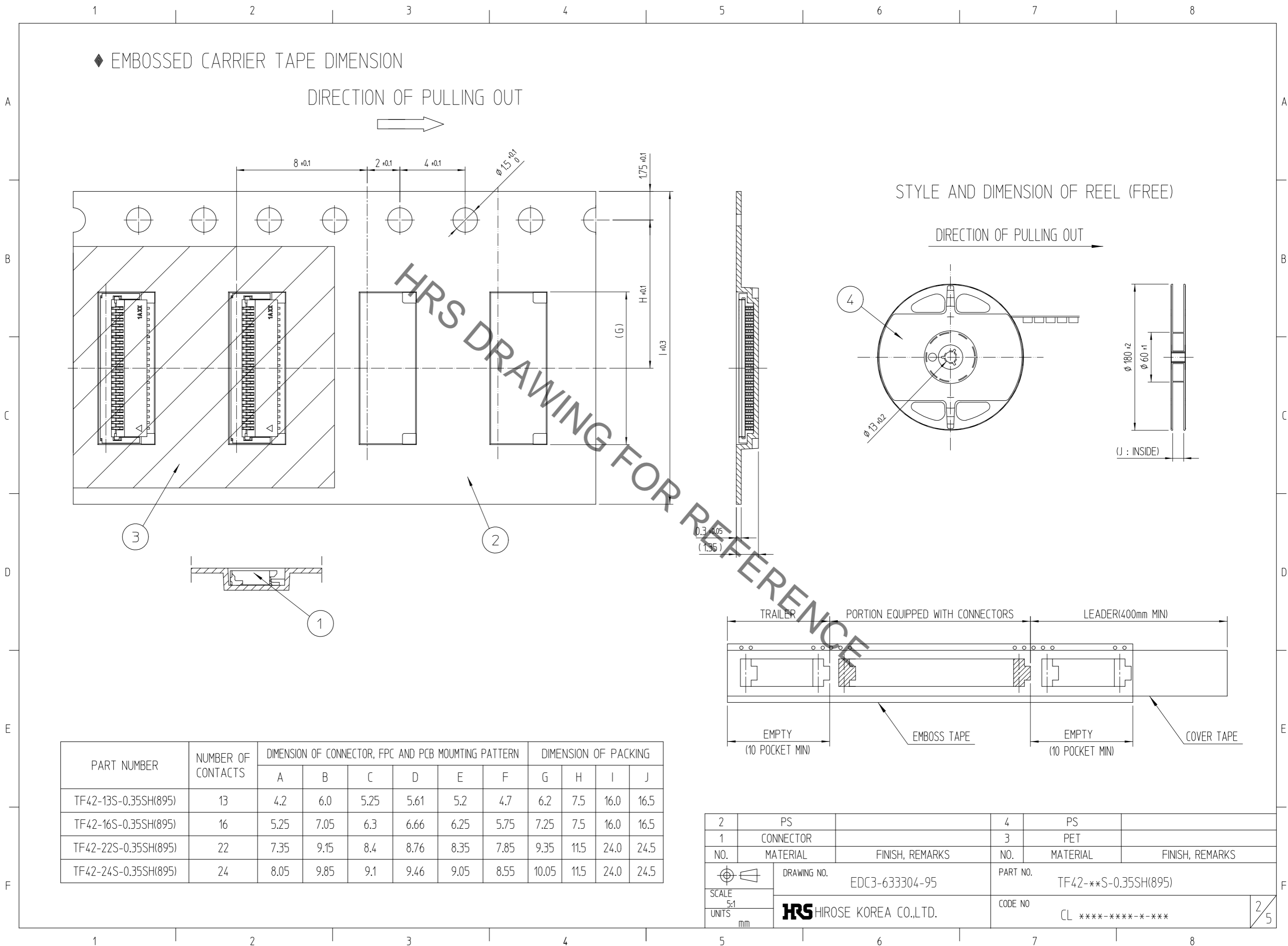

PART NUMBER	NUMBER OF CONTACTS	DIMENSION OF CONNECTOR, FPC AND PCB MOUNTING PATTERN						DIMENSION OF PACKING			
		A	B	C	D	E	F	G	H	I	J
TF42-13S-0.35SH(895)	13	4.2	6.0	5.25	5.61	5.2	4.7	6.2	7.5	16.0	16.5
TF42-16S-0.35SH(895)	16	5.25	7.05	6.3	6.66	6.25	5.75	7.25	7.5	16.0	16.5
TF42-22S-0.35SH(895)	22	7.35	9.15	8.4	8.76	8.35	7.85	9.35	11.5	24.0	24.5
TF42-24S-0.35SH(895)	24	8.05	9.85	9.1	9.46	9.05	8.55	10.05	11.5	24.0	24.5

2	PS		4	PS	
1	CONNECTOR		3	PET	
NO.	MATERIAL	FINISH, REMARKS	NO.	MATERIAL	FINISH, REMARKS
DRAWING NO. EDC3-633304-95		PART NO. TF42-**S-0.35SH(895)			
SCALE 5:1	UNITS mm		CODE NO. CL ****-****-x-***		2/5

Dec.1.2021 Copyright 2021 HIROSE ELECTRIC CO., LTD. All Rights Reserved.
In case of consideration for using Automotive equipment / device which demand high reliability, kindly contact our sales window correspondents.

◆ [Board Mounting Precautions]

◎ Board Warpage

Be sure to minimize the board warpage as much as possible.
The Lead co-planarity including reinforced material is 0.1mm or less.
Too much board warpage may result in a soldering failures or co-planarity issues.

◎ Connector Load

Do not apply a force of 0.5N or more to the connector before mounting it on the board to prevent connector damage.
Do not insert the FPC or operate the connector before mounting.

◎ Board Stress

- Splitting a large board into several pieces.
- Screwing the board.

Avoid the handling described above so that no force is exerted on the board during the assembly process.
Otherwise, the connector may become defective.

◎ Acceptable Amount of Board Warpage

A 100mm wide board has an acceptable warp range of 0.5mm or less. [Fig.1]
Excessive amounts of warping will place stress on the connector which may result in damage and malfunction.

[Fig.1]

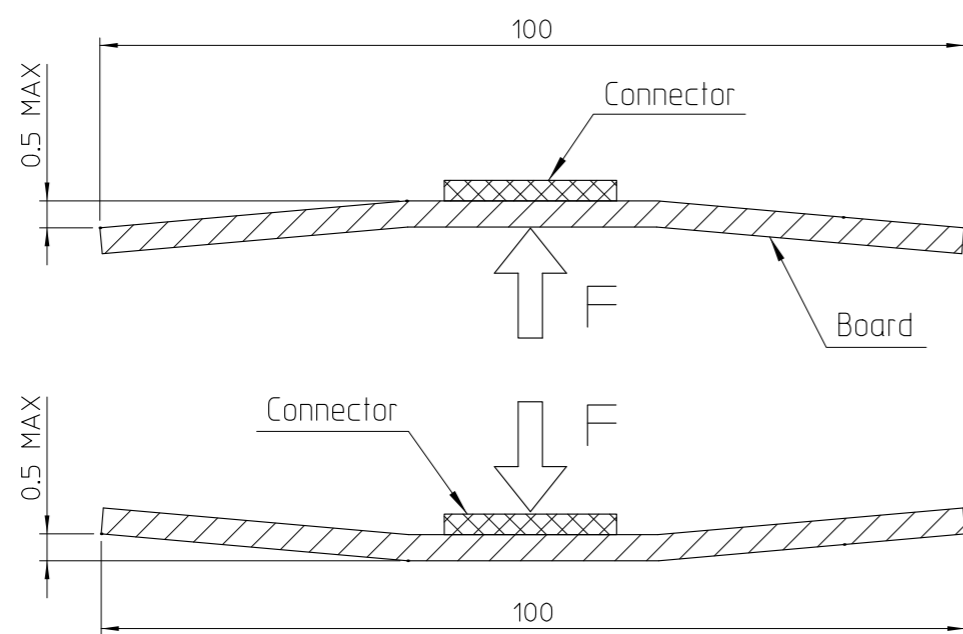

◆ [Operating Method]

As this connector is a small and thin, requires careful handling.
Please check the instructions shown below before use.

1. Initial condition.

- The actuator is delivered closed state.
- Don't operate the connector while it is not mounted on the board.

2. How to unlock the actuator

Actuator rotates around the center rotation axis, as shown in the Figure below.
Operate the actuator and slowly rotate it, releasing the lock. [Fig.2]

[Caution]

- Operate the actuator around the center when unlocked. [Fig.4]
- Do not operate the actuator on one side only when unlocked. [Fig.5]
- Actuator can not be opened wider than 99°. Do not open it wider than that angle. [Fig.3]
- This connector adopts a back-flip design, and there is a difference between the FPC insertion direction and the actuator operating direction. Don't try to open from FPC insertion side. [Fig.6]
- Do not pick and raise the actuator, or hook it. [Fig.7]

[Fig.2]

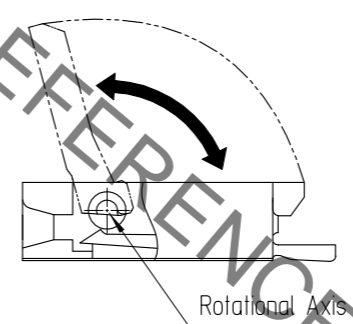

[Fig.3]

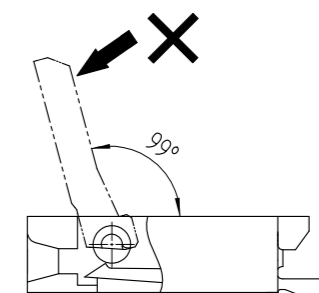

[Fig.4]

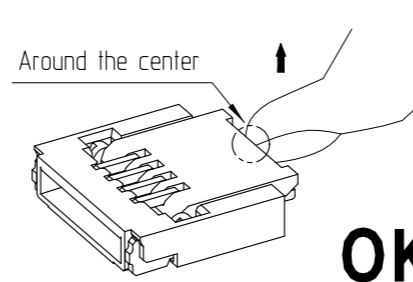

[Fig.5]

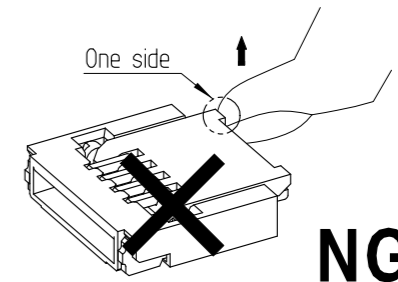

< INSTRUCTION MANUAL (1) >

 SCALE 5:1 UNITS mm	DRAWING NO.	EDC3-633304-95	PART NO.	TF42-**S-0.35SH(895)
	 HIROSE KOREA CO.,LTD.		CODE NO.	CL ****-****-*-***

1 2 3 4 5 6 7 8

A
B
C
D
E
F

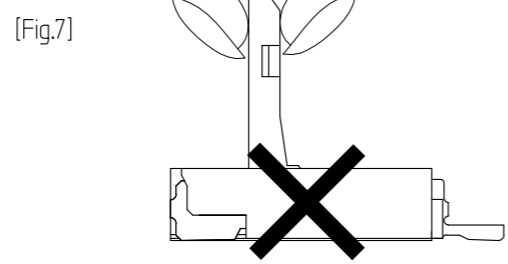
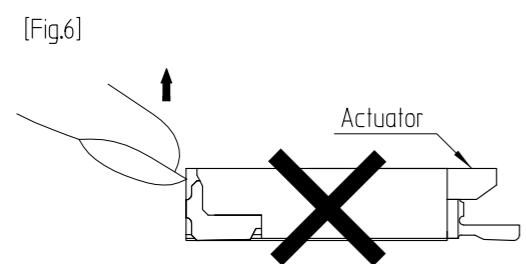

3. How to insert FPC

Insert FPC with the conductor surface facing downwards, horizontally to the board surface until fully inserted. [Fig.8]

[Caution]

- Be sure to insert FPC to the end.
- This connector has a ZIF structure and its effective engagement length is 1.92mm
- Do not insert FPC while the actuator is closed. [Fig.9]
- Do not insert FPC diagonally above and do not move it in vertical, lateral or diagonal directions while FPC insertion. [Fig.10]

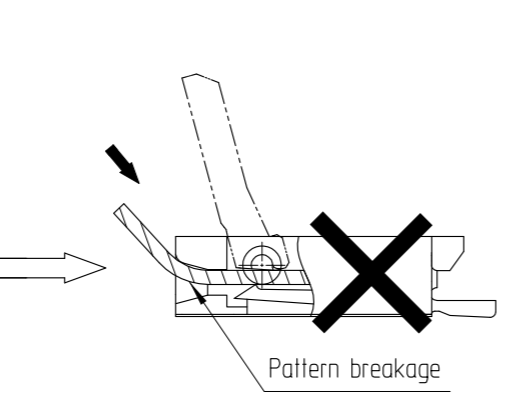
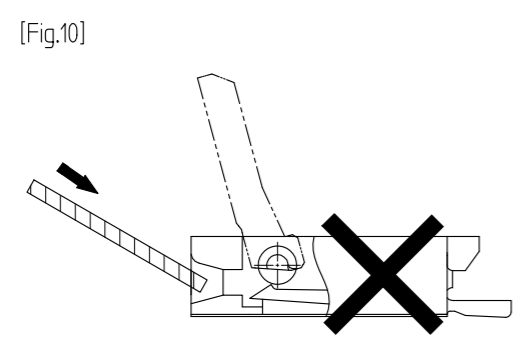
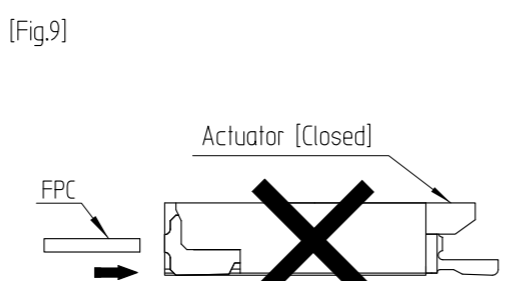
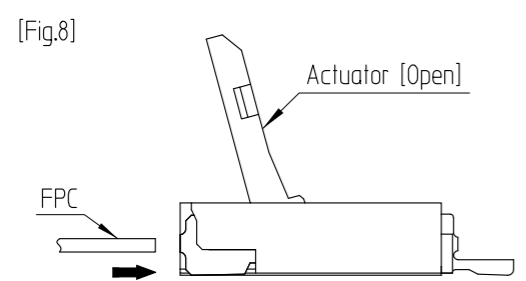

4. Actuator locking mechanism

Actuator rotates around the actuator rotation axis.
After inserting FPC, operate the actuator rotating 99°.

[Caution]

- Do not operate the actuator on one side only. [Fig.11]
- Do not operate the actuator in the direction opposite to the closing direction. [Fig.12]
- Do not operate the actuator by pushing in the vertical direction. [Fig.13]
- Please check to insure the actuator is placed horizontal to the board surface when locked.

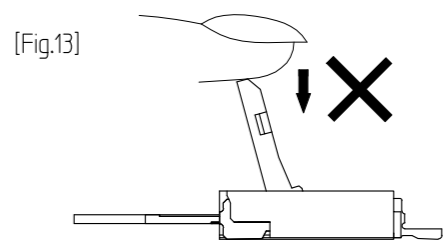
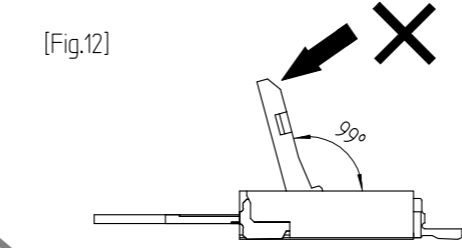
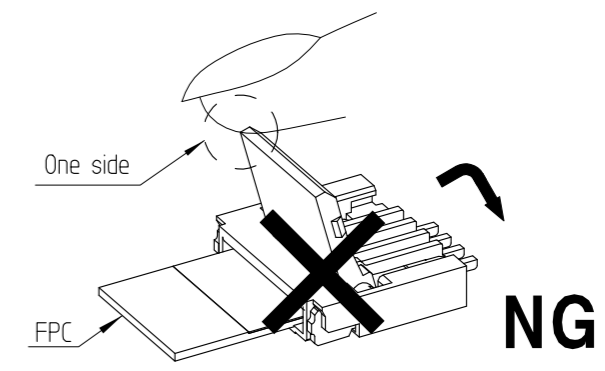
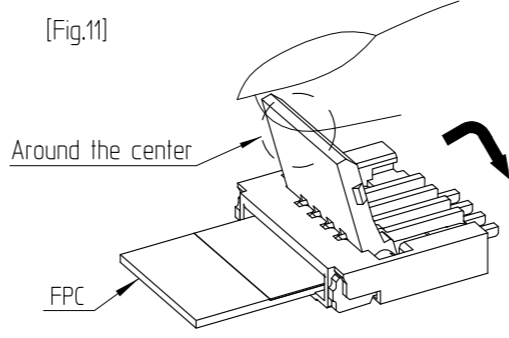

5. Checking the FPC insertion status

When FPC is completely inserted, visually inspect the inserted status of FPC.

[Caution]

- Do not insert FPC insufficiently or from a diagonal direction. [Fig.14]

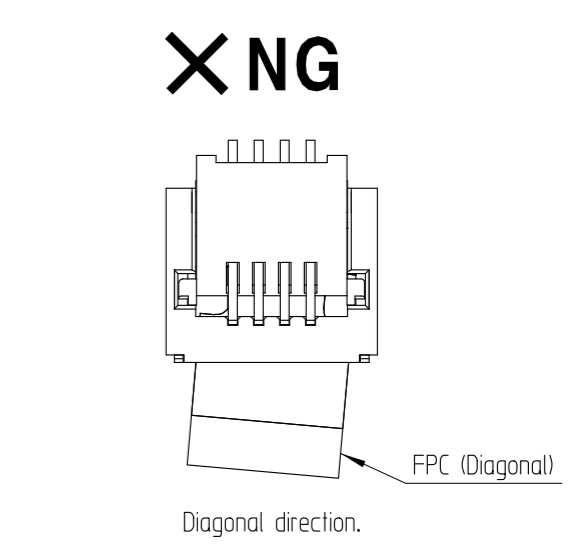
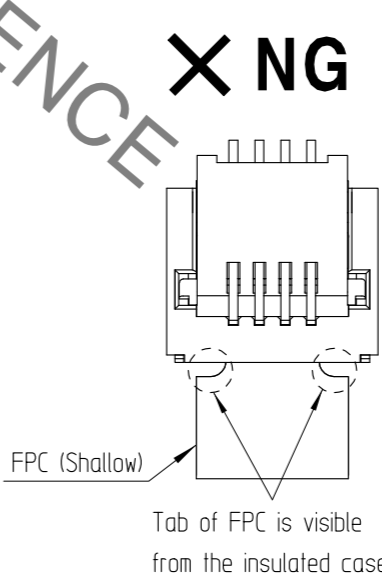
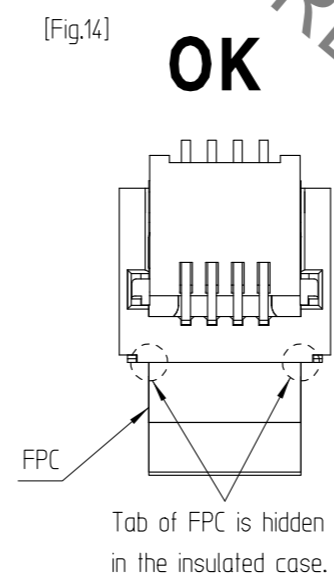

< INSTRUCTION MANUAL (2) >

 SCALE 10:1 UNITS mm	DRAWING NO.	EDC3-633304-95	PART NO.	TF42-**S-0.35SH(895)
	HIROSE KOREA CO.,LTD.		CODE NO.	CL ****-****-**-***

6. How to remove FPC

After unlock the actuator , remove the FPC in the horizontal direction. [Fig.15]

[Caution]

- Do not remove the FPC while the actuator is closed. [Fig.16]
- When pulling out FPC, do not apply load in the upward or lateral direction. [Fig.17]

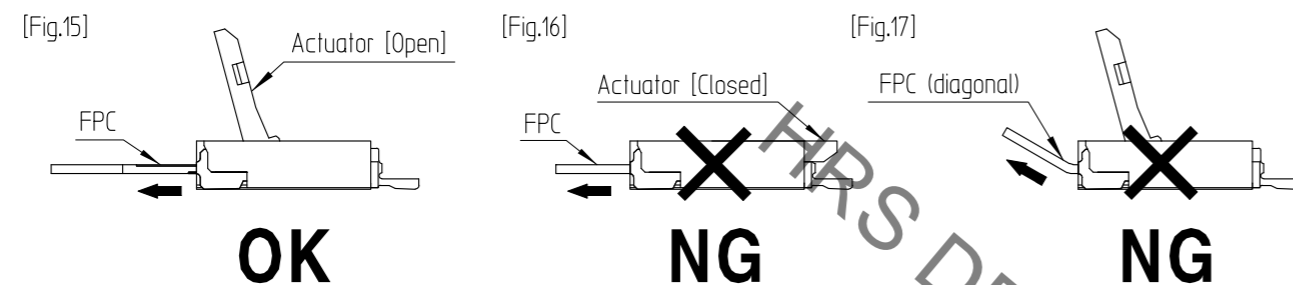

◆ [Other Instructions]

○ Manual soldering

Follow the instructions listed below when soldering the connector manually during repair work, etc.

- Do not perform reflow soldering or manual soldering with the FPC/FFC inserted into the connector.
- Do not overheat the connector.

Do not allow the soldering iron to contact any part other than the intended connector leads. Otherwise, the connector may be deformed or melted.

- Do not use excessive solder (or flux).

If excessive solder (or flux) is used on the terminals, solder or flux may adhere to the contacts or the rotating parts of the actuator, resulting in poor contact or a rotation failure of the actuator.

7. Routing of FPC

When routing the FPC please do not apply a load as it may cause FPC disconnection and damage. It also may cause additional load to the connector resulting in poor connection and other issues.

[Caution]

- When routing FPC, please be careful that FPC is not pulled and routing is carried out with a margin.
- Please check that the stiffener is parallel to the board surface. [Fig.18].
- Please insure there is no load is applied to the connector in the pulling, inserting or lateral direction. [Fig.19]
- Don't place any parts under the stiffener that will interfere with FPC. [Fig.20]

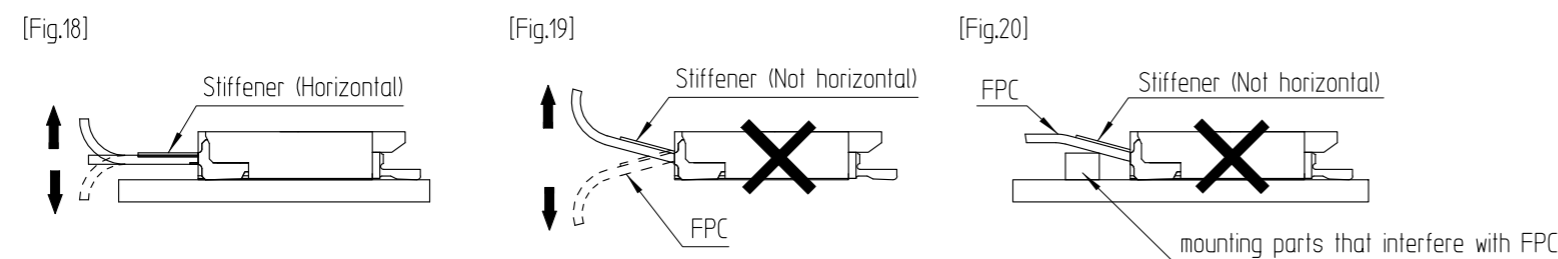

 SCALE 10:1 UNITS mm	DRAWING NO.	EDC3-633304-95	PART NO.	TF42-**S-0.35SH(895)
	HIROSE KOREA CO.,LTD.		CODE NO.	CL ****-****-*-***

Mouser Electronics

Authorized Distributor

Click to View Pricing, Inventory, Delivery & Lifecycle Information:

[Hirose Electric:](#)

[TF42-16S-0.35SH\(895\)](#)