

Long-term evolution TPM 2.0 device with an I²C interface

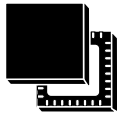

VFQFPN32
(5 × 5 mm)



Product status link

[ST33TPHF2XI2C](#)

Features

TPM features

- Flash-memory-based Trusted Platform Module (TPM)
- For TPM 2.0, compliant with Trusted Computing Group (TCG) Trusted Platform Module (TPM) Library specifications 2.0, Level 0, Revision 138 and TCG PC Client Specific TPM Platform Specifications 1.03
- Fault-tolerant firmware loader that keeps the TPM fully functional when the loading process is interrupted (self-recovery)
- SP800-193 compliant for protection, detection and recovery requirements
- Targeted certifications:
 - CC according to TPM 2.0 PP at EAL4+ (with AVA_VAN.5), resistant to high potential attacks
 - FIPS 140-2 level 2 (physical security level 3)
 - TCG certification
- I²C support at up to 400 kHz
- Supports up to 4 GPIOs mapped on NV storage indices

Hardware features

- Arm® SecurCore® SC300™ 32-bit RISC core
- Highly reliable Flash memory technology
- Extended temperature range: -40 °C to 105 °C
- ESD (electrostatic discharge) protection up to 4 kV (HBM)
- 1.8 V or 3.3 V supply voltage range

Security features

- Active shield and environmental sensors
- Monitoring of environmental parameters (power)
- Hardware and software protection against fault injection
- FIPS compliant RNG built on an SP800-90A compliant SHA256 DRBG and an AIS-31 Class PTG2 compliant true random number generator (TRNG)
- Cryptographic algorithms:
 - RSA key generation (1024 or 2048 bits)
 - RSA signature (RSASSA-PSS, RSASSAPKCS1v1_5)
 - RSA encryption (RSAES-OAEP, RSAESPKCS1-v1_5)
 - SHA-1, SHA-2 (256 and 384 bits), SHA-3 (256 and 384 bits)
 - HMAC SHA-1, SHA-2 and SHA-3
 - AES-128, 192 and 256 bits
 - TDES-192 bits
 - ECC (NIST P-256, P-384 curves): key generation, ECDH and ECDSA, EC-Schnorr
 - ECDAA (BN-256 curve)
- Device provided with 3 EK and EK certificates (RSA2048, ECC NIST P_256 and ECC NIST P_384)

- Device provisioned with 3 RSA key pairs to reduce the TPM provisioning time

Product compliance

- TPM 2.0 compliant with Microsoft® Windows® Internet of things (IoT) core
- Compliant with TCG test suite for TPM 2.0

1 Description

The STSAFE-TPM (trusted platform module) family of products offers a broad portfolio of standardized solutions for embedded, PC, mobile and computing applications. STSAFE is an ST trademark.

It includes turnkey products compliant with the Trusted Computing Group (TCG) standards that provide services to protect the confidentiality, integrity and authenticity of information and devices.

These devices are easy to integrate thanks to the variety of supported interfaces and the availability of TPM ecosystem software solutions.

The STSAFE-TPM devices are all Common Criteria (EAL4+) and FIPS certified.

They embed an Arm® SecurCore® SC300™ processor with additional security features to help protect against advanced forms of attack.

The ST33TPHF2XI2C offers an I²C interface compliant with the TCG PC Client TPM Profile specifications.

It offers resilience services during the TPM firmware upgrade process, and self-recovery of TPM firmware and critical data upon failure detection.

The ST33TPHF2XI2C operates in the –25 to +85 °C commercial temperature range at 1.8 V, or in the –40 °C to 105 °C extended temperature range at 3.3 V.

The device is offered in the VFQFPN32 ECOPACK2 package. ECOPACK is an ST trademark.

Note: Arm is a registered trademark of Arm Limited (or its subsidiaries) in the US and/or elsewhere.

arm



2 Pin and signal descriptions

The figure below gives the pinout of the VFQFPN32 package in which the devices are delivered. The table describes the associated signals.

Figure 1. VFQFPN32 pinout (top view)

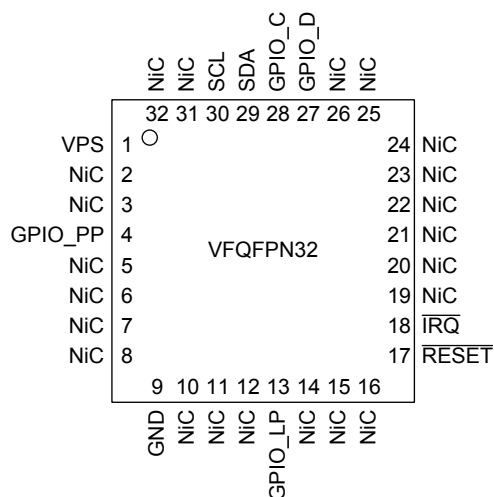

Table 1. Pin descriptions

Signal	Type	Description
VPS	Input	Power supply. This pin must be connected to the 1.8 V or 3.3 V DC power rail supplied by the motherboard.
GND	Input	GND has to be connected to the main motherboard ground.
SDA	Bidir	I ² C serial data (open drain with no weak pull-up resistor)
SCL	Input	I ² C serial clock (open drain with no weak pull-up resistor)
PIRQ	Output	Parallel IRQ used by the TPM to generate an interrupt
RESET	Input	Reset used to re-initialize the device
GPIO_C	Input/output	General-purpose input/output. Defaults to low. The GPIO function could be modified by activating GPIOs mapped on the NV storage index feature.
GPIO_D	Input/output	General-purpose input/output. Defaults to low. The GPIO function could be modified by activating GPIOs mapped on the NV storage index feature.
GPIO_PP	Input	Physical Presence , active high, internal pull-down. Used to indicate Physical Presence to the TPM. The GPIO function could be modified by activating GPIOs mapped on the NV storage index feature.
GPIO_LP	Input	By default: Used for activation and deactivation of the TPM Standby mode (not found). The GPIO function could be modified by activating GPIOs mapped on the NV storage index feature.
NiC	-	Not internally connected: not connected to the die. May be left unconnected, but has no impact on the TPM if connected.

Note: The VFQFPN32 package has a central pad (PIN33) on the bottom that is not connected to the die. This pin can be connected or left unconnected with no impact on the TPM.

3 Package information

In order to meet environmental requirements, ST offers these devices in different grades of **ECOPACK** packages, depending on their level of environmental compliance. ECOPACK specifications, grade definitions and product status are available at: www.st.com. ECOPACK is an ST trademark.

3.1 VFQFPN32 package information

VFQFPN32 is a 32-lead, 5 × 5 mm, 0.5 mm pitch, very thin fine pitch quad flat pack no-lead package.

Figure 2. VFQFPN32 - outline

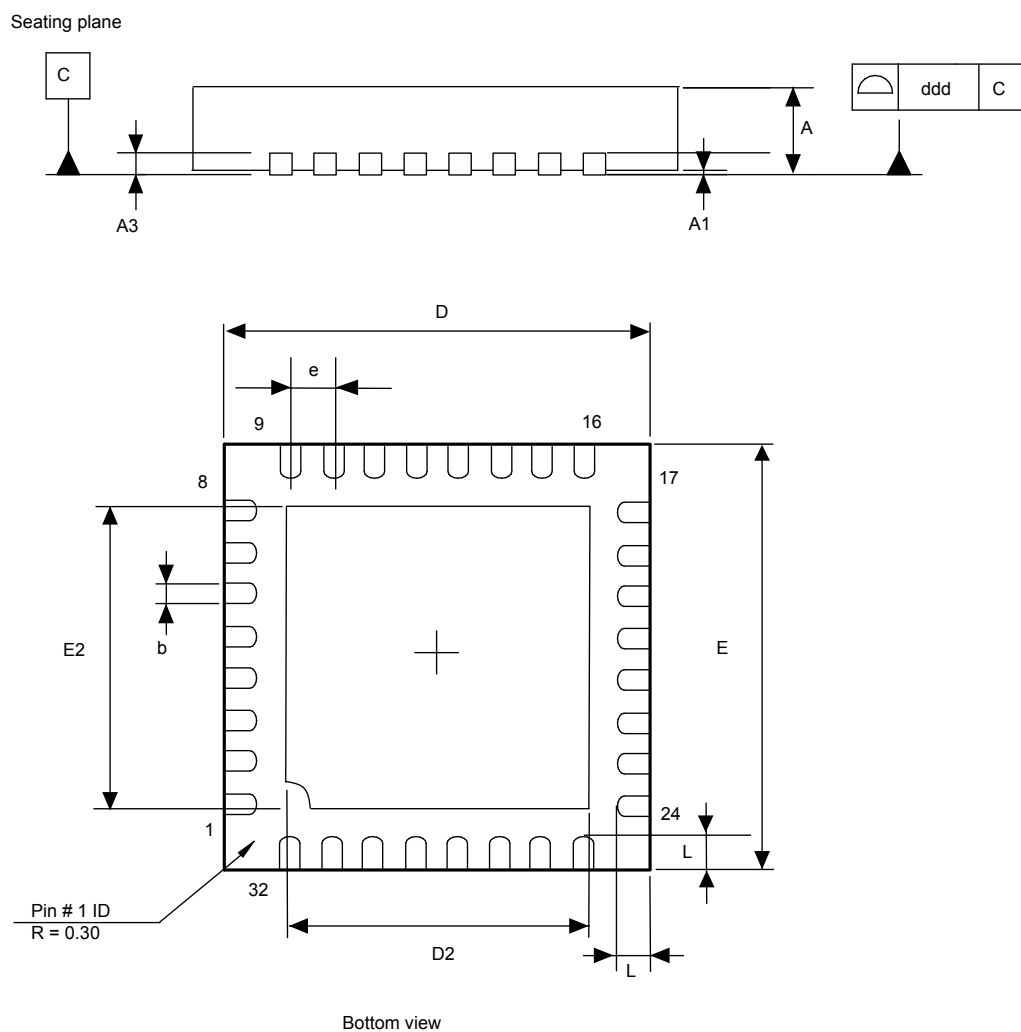

1. Drawing is not to scale.

Table 2. VFQFPN32 - mechanical data

Symbol	millimeters			inches ⁽¹⁾		
	Min.	Typ.	Max.	Min.	Typ.	Max.
A	0.800	0.900	1.000	0.0315	0.0354	0.0394
A1	0.000	0.020	0.050	0.0000	0.0008	0.0020
A3	-	0.200	-	-	0.0079	-
b	0.180	0.250	0.300	0.0071	0.0098	0.0118
D	4.850	5.000	5.150	0.1909	0.1969	0.2028
D2	3.500	3.600	3.700	0.1378	0.1417	0.1457
E	4.850	5.000	5.150	0.1909	0.1969	0.2028
E2	3.500	3.600	3.700	0.1378	0.1417	0.1457
e	-	0.500	-	-	0.0197	-
L	0.300	0.400	0.500	0.0118	0.0157	0.0197
ddd	-	-	0.050	-	-	0.0020

1. Values in inches are converted from mm and rounded to 4 decimal digits.

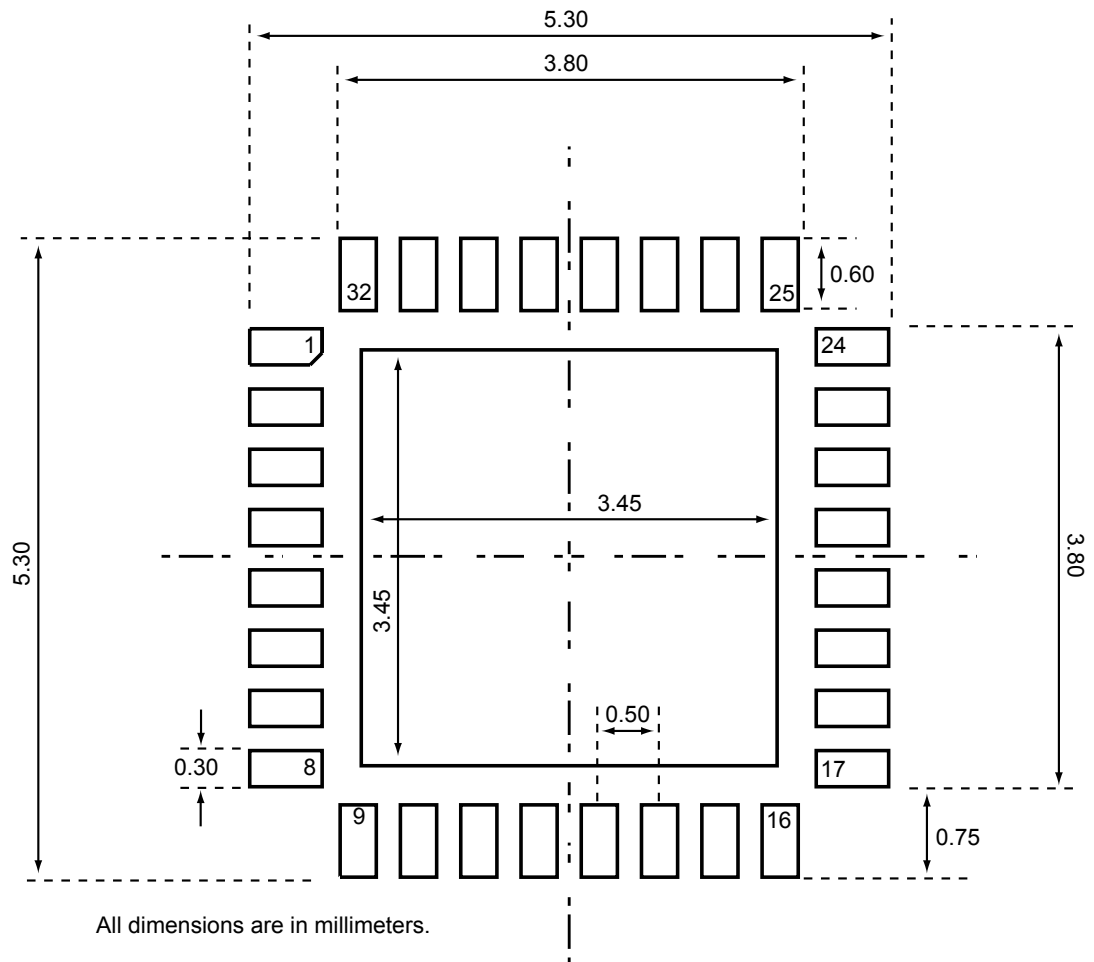
Figure 3. VFQFPN32 - recommended footprint

3.2 Thermal characteristics of packages

The table below provides the thermal characteristics of the VFQFPN32 package.

Table 3. Thermal characteristics

Parameter		Symbol	Value
Recommended operating temperature range	Ambient temperature	T_A	-40 to 105 °C
	Case temperature	T_C	-
	Junction temperature	T_J	-43 to 108 °C
Absolute maximum junction temperature		-	125 °C
Maximum power dissipation		-	63 mW
Theta-JA, -JB and -JC	Junction to ambient thermal resistance	θ_{JA}	35.8 at 0 lfpm ⁽¹⁾
	Junction to case thermal resistance	θ_{JC}	1.48 at 0 lfpm ⁽¹⁾
	Junction to board thermal resistance	θ_{JB}	13.9 at 0 lfpm ⁽¹⁾

1. Linear feet per minute.

4 Delivery packing

Surface-mount packages can be supplied with tape and reel packing. The reels have a 13" typical diameter. Reels are in plastic, either anti-static or conductive, with a black conductive cavity tape. The cover tape is transparent anti-static or conductive.

The devices are positioned in the cavities with the identifying pin (normally Pin "1") on the same side as the sprocket holes in the tape.

The STMicroelectronics tape and reel specifications are compliant with the EIA 481-A standard specification.

Table 4. Packages on tape and reel

Package	Description	Tape width	Tape pitch	Reel diameter	Quantity per reel
VFQFPN32	Very thin fine pitch quad flat pack no-lead package	12 mm	8 mm	13 in.	3000

Figure 4. Reel diagram

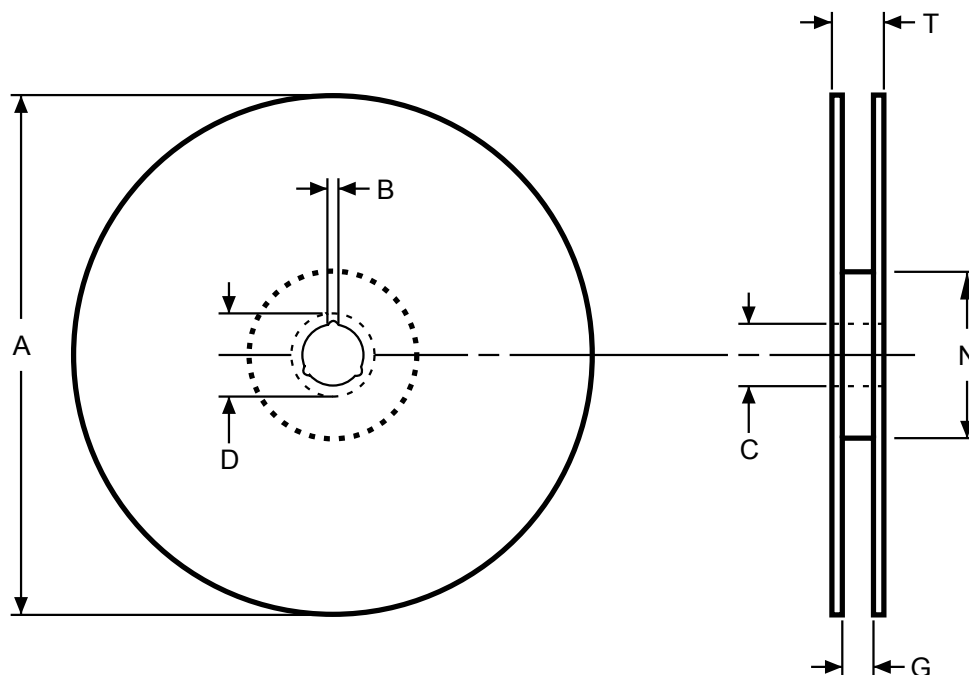
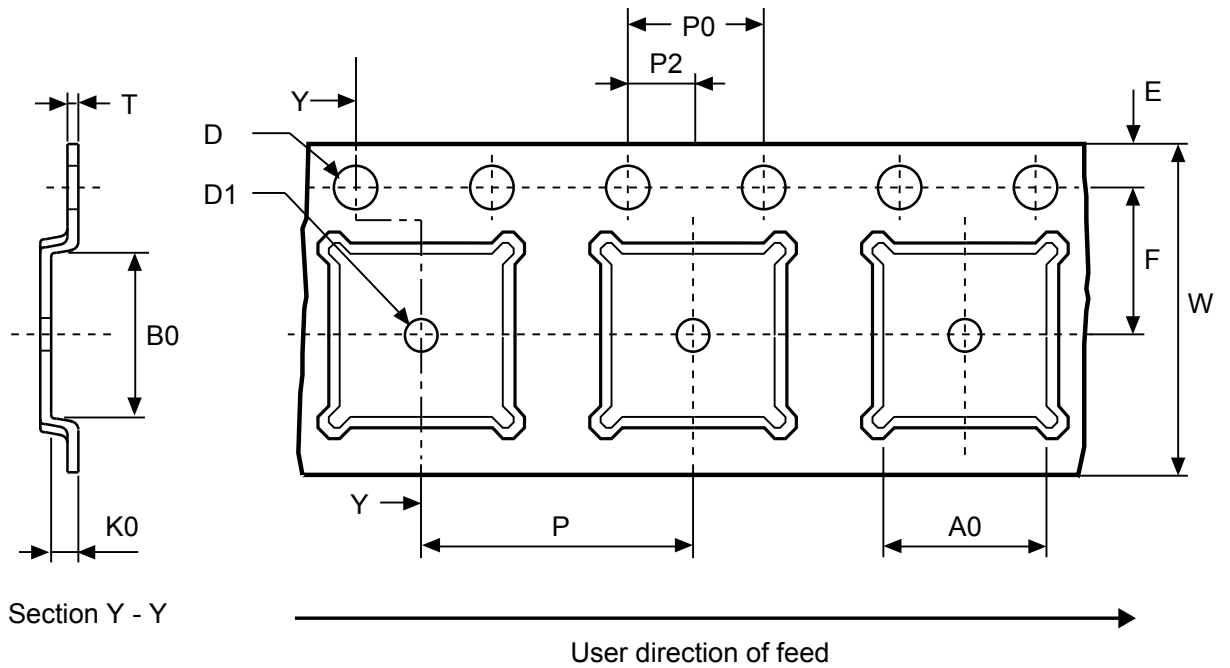

Table 5. Reel dimensions

Reel size	Tape width	A Max.	B Min.	C	D Min.	G Max.	N Min.	T Max.	Unit
13"	16	330	1.5	13 ±0.2	20.2	16.4 +2/-0	100	22.4	mm
	12					12.6		18.4	

Figure 5. Embossed carrier tape for VFQFPN32 5 × 5 mm



1. Drawing is not to scale.

Figure 6. Chip orientation in the embossed carrier tape for VFQFPN32 5 × 5 mm

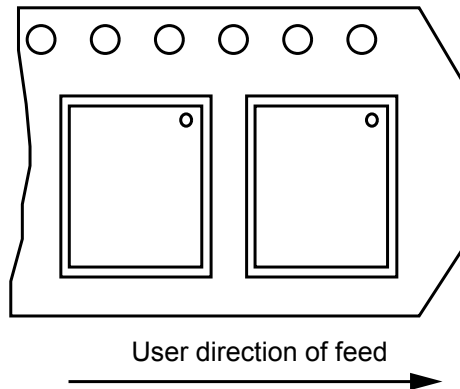

Table 6. Carrier tape dimensions for VFQFPN32 5 × 5 mm

Package	A0	B0	K0	D1 Min.	P	P2	D	P0	E	F	W	T Max.	Unit
VFQFPN 5×5	5.25 ±0.1	5.25 ±0.1	1.1 ±0.1	1.5	8 ±0.1	2 ±0.1	1.55 ±0.05	4 ±0.1	1.75 ±0.1	5.5 ±0.1	12 ±0.3	0.3 ±0.05	mm

5 Package marking information

The figure below illustrates the typical marking of the VFQFPN32 device package.

Figure 7. VFQFPN32 device package marking area

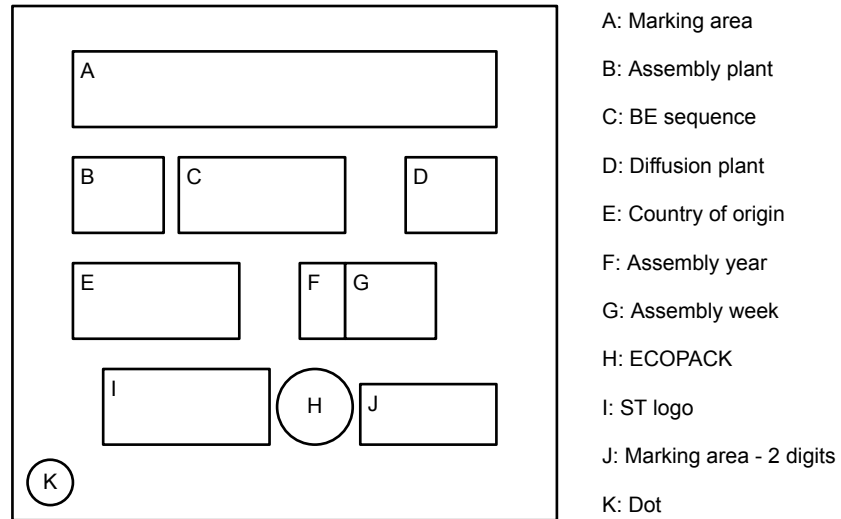

For both packages, the 6-digit 'A' marking area is equal to "PXYZZZ", with:

- Y = Hardware revision
- ZZZ = Product identifier

6 Ordering information

Table 7. Ordering information for ST33TPHF2XI2C products

Ordering code	Firmware version	Operating temperature range	Maximum I ² C clock frequency	Package	Marking (area A)	Minimum ordering quantity	Product status
ST33HTPH2X32AHC5	0x00.0x02.0x01.0x00 (0x0002.0x0100) (2.256)	-40 °C to +105 °C	400 kHz	VFQFPN32	PXAHC5	3000	Active
ST33HTPH2X32AHD5	0x00.0x02.0x.01.0x10 (0x0002.0x0110) (2.272)			VFQFPN32	PXAHD5	3000	Active and recommended for new design

7 Support and information

Additional information regarding ST TPM devices can be obtained from the www.st.com website.

For any specific support information you can contact STMicroelectronics through the following e-mail:
TPMsupport@list.st.com.

STMicroelectronics has put in place a Product Security Incident Response Team (ST PSIRT). We encourage you to report any potential security vulnerability that you might suspect in our products through the ST PSIRT web page: <https://www.st.com/psirt>.

Appendix A Terms and abbreviations

Table 8. List of abbreviations

Term	Meaning
AES	Advanced Encryption Standard
CC	Common Criteria
DAM	Dictionary attack mitigation mechanism
Data byte	Byte from the TPM command or answer or register value.
DES	Data Encryption Standard
DRBG	Deterministic random bit generator
EC	Elliptic curve
ECC	Elliptic curve cryptography
ECDA	Elliptic curve direct anonymous attestation
ECDH	Elliptic curve Diffie–Hellman
ECDSA	Elliptic curve digital signature algorithm
EK	Endorsement key
FIPS	Federal Information Processing Standard
GPIO	General-purpose I/O
HMAC	Keyed-Hashing for Message Authentication
I ² C	Inter IC interface (Philips protocol)
IoT	Internet of things
NIST	National Institute of Standards and Technology
NV	Non-volatile (memory)
OAEP	Optimal asymmetric encryption padding
PKCS	Public key cryptographic standards
PSS	Probabilistic signature scheme
RNG	Random number generator
RSA	Rivest Shamir Adelman
RSAES	Rivest Shamir Adelman encryption/decryption scheme
RSASSA	Rivest Shamir Adelman signature scheme with appendix
SHA	Secure Hash algorithm
TCG	Trusted Computed Group
TDES	Triple Data Encryption Standard
TPM	Trusted Platform Module
TRNG	True random number generator

Revision history

Table 9. Document revision history

Date	Version	Changes
09-Dec-2019	1	Initial release.
18-Jun-2020	2	Updated <i>TPM features</i> . Replaced IRQ with $\overline{\text{PIRQ}}$ in <i>Pin descriptions</i> . Updated <i>Section 6 Ordering information</i> .
19-Mar-2021	3	Removed TSSOP28 package: <ul style="list-style-type: none"> • Removed TSSOP28 silhouette from cover page. • Updated Section 1 Description. • Updated Section 2 Pin and signal descriptions. • <i>Removed TSSOP28 package information</i> section. • Updated Section 3.2 Thermal characteristics of packages. • Updated Section 4 Delivery packing. • Updated Section 5 Package marking information • Updated Section 6 Ordering information. Updated Section 7 Support and information . Small text changes throughout.

Contents

1	Description	3
2	Pin and signal description	4
3	Package information	5
3.1	VFQFPN32 package information	5
3.2	Thermal characteristics of packages	7
4	Delivery packing	8
5	Package marking information	10
6	Ordering information	11
7	Support and information	12
Appendix A	Terms and abbreviations	13
	Revision history	14
	Contents	15
	List of tables	16
	List of figures	17

List of tables

Table 1.	Pin descriptions	4
Table 2.	VFQFPN32 - mechanical data	6
Table 3.	Thermal characteristics	7
Table 4.	Packages on tape and reel	8
Table 5.	Reel dimensions	8
Table 6.	Carrier tape dimensions for VFQFPN32 5 × 5 mm	9
Table 7.	Ordering information for ST33TPHF2XI2C products	11
Table 8.	List of abbreviations	13
Table 9.	Document revision history	14

List of figures

Figure 1.	VFQFPN32 pinout (top view)	4
Figure 2.	VFQFPN32 - outline	5
Figure 3.	VFQFPN32 - recommended footprint.	6
Figure 4.	Reel diagram	8
Figure 5.	Embossed carrier tape for VFQFPN32 5 × 5 mm	9
Figure 6.	Chip orientation in the embossed carrier tape for VFQFPN32 5 × 5 mm.	9
Figure 7.	VFQFPN32 device package marking area	10

IMPORTANT NOTICE – PLEASE READ CAREFULLY

STMicroelectronics NV and its subsidiaries (“ST”) reserve the right to make changes, corrections, enhancements, modifications, and improvements to ST products and/or to this document at any time without notice. Purchasers should obtain the latest relevant information on ST products before placing orders. ST products are sold pursuant to ST’s terms and conditions of sale in place at the time of order acknowledgement.

Purchasers are solely responsible for the choice, selection, and use of ST products and ST assumes no liability for application assistance or the design of Purchasers’ products.

No license, express or implied, to any intellectual property right is granted by ST herein.

Resale of ST products with provisions different from the information set forth herein shall void any warranty granted by ST for such product.

ST and the ST logo are trademarks of ST. For additional information about ST trademarks, please refer to www.st.com/trademarks. All other product or service names are the property of their respective owners.

Information in this document supersedes and replaces information previously supplied in any prior versions of this document.

© 2021 STMicroelectronics – All rights reserved

Mouser Electronics

Authorized Distributor

Click to View Pricing, Inventory, Delivery & Lifecycle Information:

[STMicroelectronics:](#)

[ST33HTPH2X32AHD5](#)