

NxH3670UK

Ultra-low power 2.4 GHz Bluetooth Low Energy transceiver for audio streaming

Rev. 3.3 — 13 November 2020

Product data sheet

1 General description

The NXH3670UK constitutes a highly integrated, single chip ultra-low power 2.4 GHz wireless transceiver with embedded MCU, targeted at wireless audio streaming for hearables, wireless headsets, and headphones.

The NXH3670UK chip integrates the following key functionalities – among others:

- A 2.4 GHz RF transceiver and digital modem supporting up to 2 Mbps/s
- Supporting Bluetooth Low Energy GFSK modulation 1 Mbps and 2 Mbps
- A low-power 16 MHz/32 MHz crystal oscillator and on-chip oscillators
- An RF MAC for supporting the lower protocol layers
- A Cortex-M0 subsystem for system control and higher protocol layers
- An AES-128 security coprocessor
- Audio interfaces and audio processing accelerators
- A CoolFlux DSP for audio processing
- Multiple user interfaces for control, data, debug, and test

CAUTION



This device is sensitive to ElectroStatic Discharge (ESD). Observe precautions for handling electrostatic sensitive devices.

Such precautions are described in the *ANSI/ESD S20.20*, *IEC/ST 61340-5*, *JESD625-A* or equivalent standards.

CAUTION



Semiconductors are light sensitive. Exposure to light sources can cause the IC to malfunction.

The IC must be protected against light. The protection must be applied to all sides of the IC..

Unless otherwise specified:

- Typical values are at room temperature (25 °C) with nominal supply voltages of 1.2 V.
- Minimum/Maximum values are valid over operating temperature and voltage range as specified in [Table 26](#).



2 Features and benefits

- Transceiver characteristics
 - 2.402 GHz to 2.480 GHz carrier frequency
 - Bluetooth Low Energy 1 Mbps and 2 Mbps PHY modes
 - 2 MHz channels in 1 Mbps and 2 Mbps modes
- Receiver characteristics:
 - Sensitivity –90 dBm in Bluetooth Low Energy 2 Mbps modulation mode
 - Sensitivity –94 dBm in Bluetooth Low Energy 1 Mbps modulation mode
 - Frequency offset correction up to ± 300 kHz.
 - RSSI measurement with ± 3 dB accuracy
- Transmitter characteristics:
 - Programmable TX output power of –10 dBm to +4 dBm in steps of 2 dBm
- Synthesizer characteristics:
 - Fully integrated PLL, no external loop filter components
- Integrated power management:
 - Low voltage supply 1.2 V
 - Integrated supply generation for sensitive radio blocks
 - Integrated supply generation for digital and memories
 - Flexible low-power states
- Clock generation:
 - Integrated low-power crystal oscillator
 - Support for 16 MHz or 32 MHz crystals with ± 60 ppm accuracy and crystal trimming
 - On chip oscillators, including ultra low-power oscillator
- Low current consumption:
 - Sleep current < 63 μ A
 - Continuous RX current < 3.7 mA at 1.2 V
 - Continuous TX current < 7.3 mA at 1.2 V (0 dBm output power)
- MCU subsystem:
 - ARM Cortex-M0 up to 16 MHz in low-power mode and 84 MHz in high-performance mode
 - Flexible DMA engine
 - Serial debug interface
- Control/Data interfaces:
 - SPI slave
 - UART
 - GPIOs
- RF MAC:
 - Dedicated RF MAC accelerator
 - AES security coprocessor
 - Packet processing
 - Timers
 - CRC, whitening

- Audio interfaces and processing
 - I²S and TDM interface
 - G.722 codec accelerator
 - CoolFlux DSP up to 16 MHz in low-power mode and 84 MHz in high-performance mode
 - Asynchronous sample rate converter (ASRC)
 - Latency control
- Host-assisted boot via SPI
- Certified for Bluetooth specification version 4.2
- WLCSP package < 7.25 mm² (maximum die size after sawing) with 34 bumps
- Low number of external passive components
- Pb-free and compliant with RoHS Directive 2011/65/EU (RoHS 2)
- Operating temperature -20 °C to +85 °C

3 Applications

The main application target is gaming headsets, wireless headsets, and headphones.

Thanks to its support for audio, control and data, the NXH3670UK can be used in many applications where ultra-low power and small size are required.

Additional typical applications are mobile phone accessories and computer peripherals.

4 Ordering information

Table 1. Ordering information

Type number	Package		
	Name	Description	Version
NXH3670UK	WLCSP34	waver level chip-scale package; 34 bumps; 2.45 × 2.87 × 0.38 mm	SOT1403-1

5 Block diagram

[Figure 1](#) shows an overview of the NXH3670UK architecture. The NXH3670UK consists of the following subsystems:

- RF radio:
 - An RF radio transceiver
 - Digital RF modem and calibration logic
- Wireless link controller:
 - A clock shop for dividing, multiplexing, and calibrating clocks
 - An ARM Cortex running up to 16 MHz in low-power mode and 84 MHz in high-performance mode:
 - ROM for program
 - RAM for program and data
 - DMA engine
 - A flexible RF MAC for the lower protocol layers:
 - An RF MAC controller interfacing to the radio
 - Packet transmit and receive
 - CRC/whitening/assembly/dis-assembly accelerators
 - Timers
 - An AES security coprocessor
 - Audio processing unit:
 - Latency control unit
 - Dual context G.722
 - Sample rate converter
 - A CoolFlux audio DSP with associated memories and DMA engine
 - Interfaces:
 - General-purpose IOs
 - A debug and test UART
 - An SPI slave
 - An audio port supporting I²S and TDM modes
 - Timers
 - A watchdog timer
 - A random number generator
- Power Management Unit (PMU):
 - Voltage regulators
 - Power-on reset (POR)
 - Brownout detection (BOD)
 - Power management and reset controller, sleep timer, persistent register file
- A 16 MHz/32 MHz crystal oscillator and various internal oscillators
- A versatile IO switch matrix

These subsystems are described in more detail in [Section 7](#).

Ultra-low power 2.4 GHz Bluetooth Low Energy transceiver for audio streaming

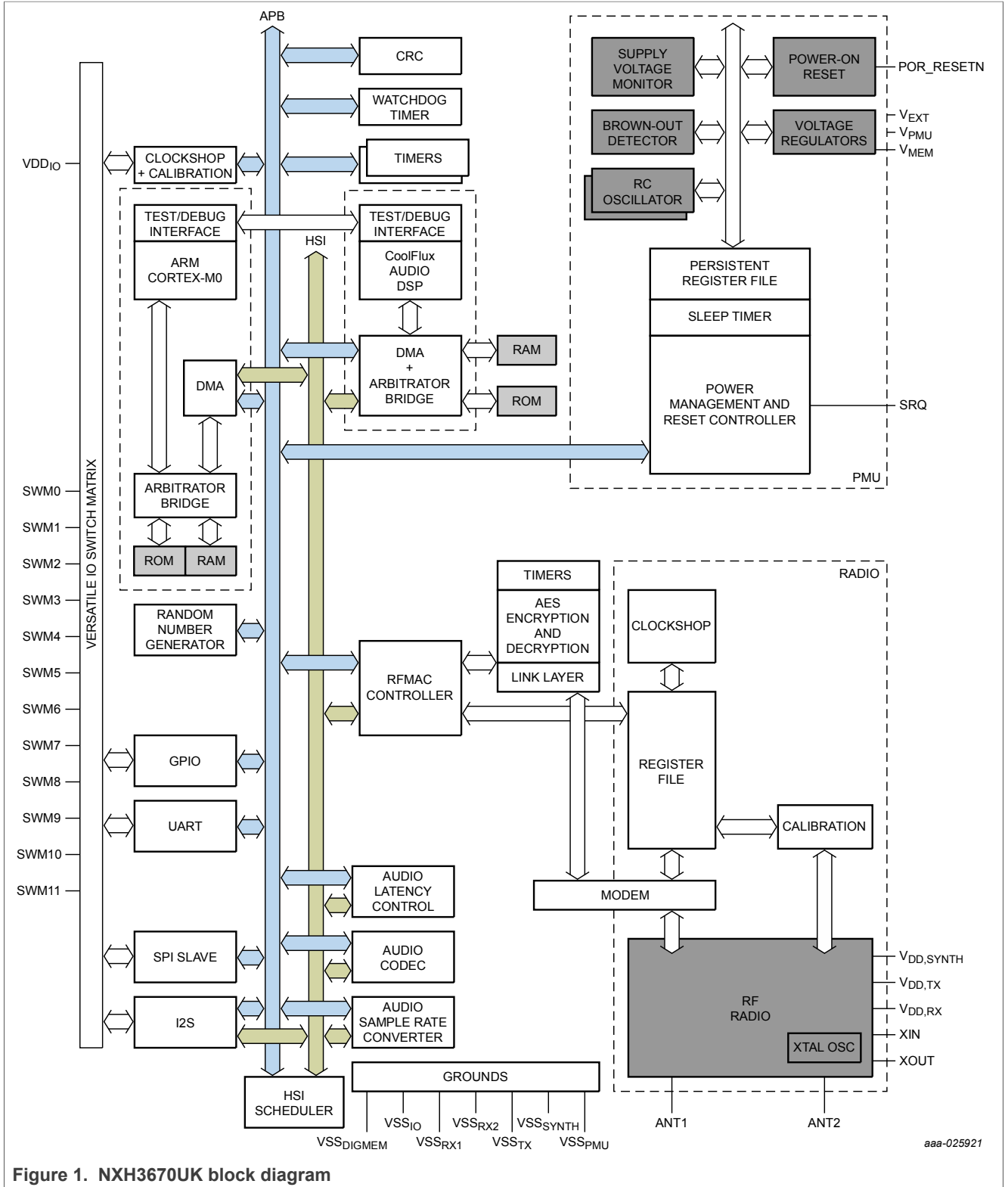

aaa-025921

Figure 1. NxH3670UK block diagram

6 Package and pinning information

This chapter provides an overview on the NXH3670UK package and pinning.

6.1 Package

Figure 2 shows the NXH3670UK bump layout

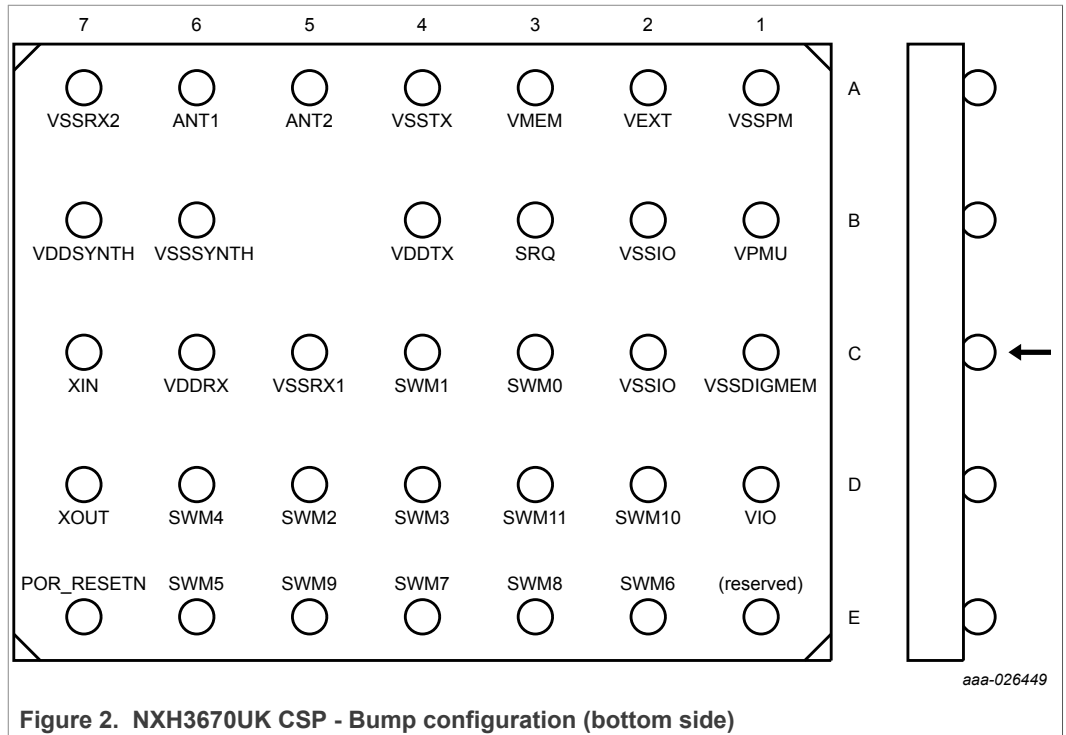

Figure 2. NXH3670UK CSP - Bump configuration (bottom side)

6.2 Pinning

Table 2 lists the bump assignments, usage, and associated pad type. The different types are:

- PWR: supply bump
- GND: ground bump
- RF: RF signal bump
- A: analog bump
- DIO: digital IO bump

At start-up, all digital IOs are set in 3-state input mode.

Ultra-low power 2.4 GHz Bluetooth Low Energy transceiver for audio streaming

Table 2. NXH3670UK bumping

Bump	Symbol	Type	Description
Supply			
A2	V _{EXT}	PWR	external power supply
D1	V _{IO}	PWR	IO bumps power supply
A3	V _{MEM}	PWR	To be used for external decoupling of internal supply node. Do not use to supply external circuit (externally connected to V _{EXT})
B1	V _{PMU}	PWR	supply of the analog part of the PMU (externally connected to V _{EXT})
B4	V _{DD,TX}	PWR	RF TX power supply (externally connected to V _{EXT})
C6	V _{DD,RX}	PWR	RF RX power supply (externally connected to V _{EXT})
B7	V _{DD,SYNTH}	PWR	RF synthesizer power supply (externally connected to V _{EXT})
Ground			
C1	V _{SS,DIGMEM}	GND	ground for the digital core and memories
C5	V _{SS,RX1}	GND	ground for the radio receiver
A7	V _{SS,RX2}	GND	ground for the radio receiver
A4	V _{SS,TX}	GND	ground for the radio transmitter
B6	V _{SS,SYNTH}	GND	ground for the radio synthesizer
A1	V _{SS,PMU}	GND	ground for the PMU
C2	V _{SS,IO}	GND	ground for the digital IO pads and ESD structures
B2	V _{SS,IO}	GND	ground for the digital IO pads and ESD structures
Radio			
A6	ANT1	RF	balanced antenna connection terminal 1
A5	ANT2	RF	balanced antenna connection terminal 2
XOSC			
C7	XIN	A	crystal oscillator input terminal
D7	XOUT	A	crystal oscillator output terminal
IO-SWM			
C3	SWM0	DIO	general-purpose digital IO
C4	SWM1	DIO	general-purpose digital IO
D5	SWM2	DIO	general-purpose digital IO
D4	SWM3	DIO	general-purpose digital IO
D6	SWM4	DIO	general-purpose digital IO
E6	SWM5	DIO	general-purpose digital IO
E2	SWM6	DIO	general-purpose digital IO
E4	SWM7	DIO	general-purpose digital IO
E3	SWM8	DIO	general-purpose digital IO
E5	SWM9	DIO	general-purpose digital IO

Table 2. NXH3670UK bumping...continued

Bump	Symbol	Type	Description
D2	SWM10	DIO	general-purpose digital IO
D3	SWM11	DIO	general-purpose digital IO
Miscellaneous			
E7	POR_RESETN	DIO	reset pin; active LOW, referenced to VBAT
B3	SRQ	DI	service request; to be used by host to change power states.
E1	-	-	(reserved)

7 Functional description

7.1 RF radio transceiver

7.1.1 Features

The RF radio transceiver implements the complete physical layer of a 2.4 GHz ultra low-power RF wireless link. It includes:

- RF functions and power and timing management
- Integrated analog RF front end with combined Rx/Tx interface
- Symbol demodulation and timing/frequency recovery blocks
- Gaussian frequency shift keying (GFSK) with the following modulation parameters:
 - Bluetooth Low Energy 2 Mbps mode
 - $h = 0.5$
 - $BT = 0.5$
 - 2 Mbps throughput mode
 - Bluetooth Low Energy 1 Mbps mode
 - $h = 0.5$
 - $BT = 0.5$
 - 1 Mbps throughput mode
- Accurate received signal strength indicator (RSSI)
- Integrated frequency synthesizer
- Automatic gain control
- Programmable transmit power
- Trimming and calibration during chip production, removing the need for trimming in the application
- Continuous wave (CW) transmit for test mode

The RF radio transceiver consists of 3 functional blocks:

- The synthesizer, which generates the RF carrier
- The receiver
- The transmitter

The specifications for each of these blocks are described in [Section 7.1.2](#), [Section 7.1.3](#), and [Section 7.1.4](#). They are guaranteed on NXH3670UK reference board schematics and layout.

In-band specifications are referred to RF antenna bumps.

Out-of-band specifications include band-pass filtering of reference board.

7.1.2 Synthesizer specification

[Table 3](#) summarizes the key specifications of the RF synthesizer.

Table 3. Synthesizer specifications

Symbol	Parameter	Min	Typ	Max	Unit
f_c	Carrier frequency	2402	-	2480	MHz
$f_{c,res}$	Carrier frequency resolution	-	1	-	MHz
$f_{ch,2Mbps}$	Non-overlapping channel spacing (2 Mbps and 1 Mbps modes)	-	2	-	MHz
T_{PLL}	PLL turn-on/hop settling time	-	50	-	μs
T_{txrx}	TX/RX turn around time using same channel	-	40	-	μs

7.1.3 Transmitter specification

[Table 4](#) to [Table 6](#) contain the detailed specifications of the RF transmitter.

Table 4. Transmitter generic specifications

Symbol	Parameter	Min	Typ	Max	Unit
P_{RF}	lowest TX output power range	-	-10	-	dBm
	highest TX output power range	-	4	-	dBm
ΔP_{RF}	TX output power: programming step size	-	2	-	dBm
P_{tol}	output power tolerance at 0 dBm ^[1]	-	± 1.5	-	dBm
Z_{OUT}	output impedance - balanced	-	99-j42	-	Ω
$P_{2,harm}$	power in 2 nd harmonic: all rates at 0 dBm	-	-	-30	dBm
	power in 2 nd harmonic: all rates at 4 dBm	-	-	-25	dBm
$P_{3,harm}$	power in 3 rd harmonic: all rates at 0 dBm	-	-	-30	dBm
	power in 3 rd harmonic: all rates at 4 dBm	-	-	-25	dBm
$P_{4,harm}$	power in 4 th harmonic: all rates at 0 dBm	-	-	-30	dBm
	power in 4 th harmonic: all rates at 4 dBm	-	-	-30	dBm
P_{spur}	spurious emissions (all output levels and rates) ^[2]				
	30 MHz to 1000 MHz	-	-	-36	dBm
	1 GHz to 12.75 GHz	-	-	-30	dBm
	47 MHz to 74 MHz	-	-	-54	dBm
	87.5 MHz to 108 MHz	-	-	-54	dBm
	174 MHz to 230 MHz	-	-	-54	dBm
	470 MHz to 862 MHz	-	-	-54	dBm
$P_{spur0dBm}$	spurious emissions for $P_{out} < 0$ dBm, 2.0 GHz to 3.0 GHz	-	-60	-45	dBm

Table 4. Transmitter generic specifications...continued

Symbol	Parameter	Min	Typ	Max	Unit
Δh_{2Mbps}	frequency deviation accuracy (2 Mbps – 0 dBm)	-	± 3	$\pm 7^{[3]}$	%
Δh_{1Mbps}	frequency deviation accuracy (1 Mbps – 0 dBm)	-	± 3	$\pm 7^{[3]}$	%

[1] Measured at 25 °C, full supply voltage range, tested with lab supply. Assuming perfect matching.
 [2] Complies with EN 300 440 -1 V1.6.1, EN 300 328 V1.8.1, FCC CFR 47 part 15, ARIB STD-66, RSS-210
 [3] Maximum value over temperature and for a supply exceeding 1.05 V

Table 5. Transmitter mode 2 Mbps Bluetooth Low Energy specifications

Symbol	Parameter	Min	Typ	Max	Unit
BW_{A2Mbps}	20 dB bandwidth	-	2.06	-	MHz
$ACPR_{A2Mbps}$	Adjacent Channel Power Ratio	-	-	-30	dBc
$AACPR_{A2Mbps}$	Alternate Adjacent Channel Power Ratio	-	-	-50	dBc

Table 6. Transmitter mode 1 Mbps Bluetooth Low Energy specifications

Symbol	Parameter	Min	Typ	Max	Unit
BW_{BLE}	20 dB bandwidth	-	1.030	-	MHz
$ACPR_{BLE}$	Adjacent Channel Power Ratio	-	-	-30	dBc
$AACPR_{BLE}$	Alternate Adjacent Channel Power Ratio	-	-	-50	dBc

7.1.4 Receiver specifications

Table 7 to Table 9 contain the detailed specifications of the RF radio receiver.

The following conventions are chosen:

- Maximum input power $P_{in,max}$ is given for a BER of 10^{-3}
- RX sensitivity $P_{RX,*}$ is defined for a BER of 10^{-3} for all modes

BER of 10^{-3} corresponds to a PER of 30.8 % since a packet length of 46 bytes is used according to the Bluetooth Low Energy RF PHY test specification

- Co-channel interference $C/I_{CO,*}$ and ACS (C/I) are measured with a wanted signal at -67 dBm and one interferer having the same modulation as the wanted signal. The measurement is done according to the Bluetooth Low Energy RF PHY test spec for all different modes
- IMD is measured with a wanted signal at -64 dBm and 2 interferers having the same power. The closest interferer is a CW signal and the other interferer has the same modulation as the wanted signal. The largest power of the interfering signals for which the wanted signal fulfills the sensitivity criterion is reported. The measurement is done according to the Bluetooth Low Energy RF PHY test spec for all different modes.

Ultra-low power 2.4 GHz Bluetooth Low Energy transceiver for audio streaming

Table 7. Receiver generic specifications

Symbol	Parameter	Min	Typ	Max	Unit
$P_{in,max}$	maximum input power	-	-10	-	dBm
LO_{leak}	LO leakage	-	-70	-	dBm
OBB	out of band blocking ^[1]				
	30 MHz to 2000 MHz	-	0	-	dBm
	2003 MHz to 2399 MHz	-	-10	-	dBm
	2484 MHz to 2997 MHz	-	-10	-	dBm
	3000 MHz to 12.75 GHz	-	+10	-	dBm
$RSSI_{dyn}$	RSSI dynamic range	-90	-	-10	dBm
$RSSI_{tol}$	RSSI tolerance	-3	-	+3	dBm
$RSSI_{res}$	RSSI resolution (monotonically)	-	-	3	dBm
IR	image Rejection, C/I ^[2]	-	-28	-	dB
$P_{spur,RX}$	spurious emissions RX - 25 MHz to 1 GHz	-	-	-57	dBm
	spurious emissions RX - above 1 GHz	-	-	-47	dBm
Z_{in}	input impedance	-	99-j42	-	Ω

[1] As defined by Bluetooth Low Energy standard (Bluetooth spec 4.0 – Volume 6 – Part A – section 4.3).

[2] Measured at 0.1 % BER, desired signal 3 dB above sensitivity. Image frequency is 2 MHz below the RF frequency in 1 Mbps mode and 3 MHz above the RF frequency in 2 Mbps mode.

Table 8. Receiver mode 2 Mbps Bluetooth Low Energy specifications

Symbol	Parameter	Min	Typ	Max	Unit
$P_{Rx,2Mbps}$	RX sensitivity	-	-90	-	dBm
$C/I_{CO,2Mbps}$	co-channel C/I	-	8	-	dB
$ACS_{1,2Mbps}$	C/I at 2 MHz	-	-4	-	dB
$ACS_{2,2Mbps}$	C/I at 4 MHz	-	-28	-	dB
$ACS_{N,2Mbps}$	C/I at $\Delta f \geq 10$ MHz	-	-45	-	dB
IMD_{2Mbps}	CW at 6 MHz/8 MHz/10 MHz	-	-36	-	dBm

Table 9. Receiver mode 1 Mbps Bluetooth Low Energy specifications

Symbol	Parameter	Min	Typ	Max	Unit
$P_{Rx,BLE}$	RX Sensitivity	-	-94	-	dBm
$C/I_{CO,BLE}$	co-channel C/I	-	8	-	dB
$ACS_{1,BLE}$	C/I at 1 MHz	-	-2	-	dB
$ACS_{2,BLE}$	C/I at 2 MHz	-	-28	-	dB
$ACS_{N,BLE}$	C/I at $\Delta f \geq 10$ MHz	-	-45	-	dB
IMD_{BLE}	CW at 3 MHz/4 MHz/5 MHz	-	-36	-	dBm

7.2 Wireless link controller

The sections below are intended to give a summary of the functionality implemented in the wireless link controller.

7.2.1 On-chip buses

7.2.1.1 Advanced peripheral bus (APB)

Both the ARM Cortex-M0 and the CoolFlux audio DSP are masters on the APB. This bus is intended for configuration and status reporting.

The host can access all peripherals on the APB through the software API.

7.2.1.2 HSI data bus

The High-speed interface (HSI) scheduler enables peripherals to access the HSI Data bus using a fixed schedule. The HSI data bus provides scheduled bus access with two-way handshaking between the source and destination peripheral.

7.2.2 ARM Cortex-M0 MCU subsystem

The ARM Cortex-M0 MCU subsystem consists of:

- An ARM Cortex-M0
- 128 kB ROM
- 96 kB RAM
- HSI/APB bridge
- 8 DMA channels; interfacing between the Cortex-M0 memories and the HSI data bus

The ARM Cortex-M0 is designed to run at a frequency up to 84 MHz. The maximum operating frequency is however dependent on the core voltage, allowing to trade off between high frequency and low current consumption.

The ARM Cortex-M0 is intended to control the overall system and execute the firmware for higher protocol layers. the RF MAC controller typically handles the lower protocol layers.

Table 10. ARM Cortex-M0 memories

Memory	Value
RAM size	24 K × 32 bit [96 kB]
ROM size	32 K × 32 bit [128 kB]

Table 11. ARM Cortex-M0 configuration

Parameter	Value
Endianness	little endian
Debug port	Serial Wire (SW-DBG)

7.2.3 SPI slave

The SPI slave hardware module provides the interface through which an external host can communicate as master with the wireless link controller. The SPI slave adheres to the 4-wire SPI specification, supporting operation mode 0.

The SPI slave includes:

- 2 buffers (RX and TX) of 72 bytes each:
 - RX buffer: used to transmit message from external host to Cortex-M0
 - TX buffer: used to transmit message from Cortex-M0 to external host
- Flow control settings and status to manage the packet transfers

To allow the controller to request an SPI transfer, a signaling line (GPIO) from the controller to the host can be used.

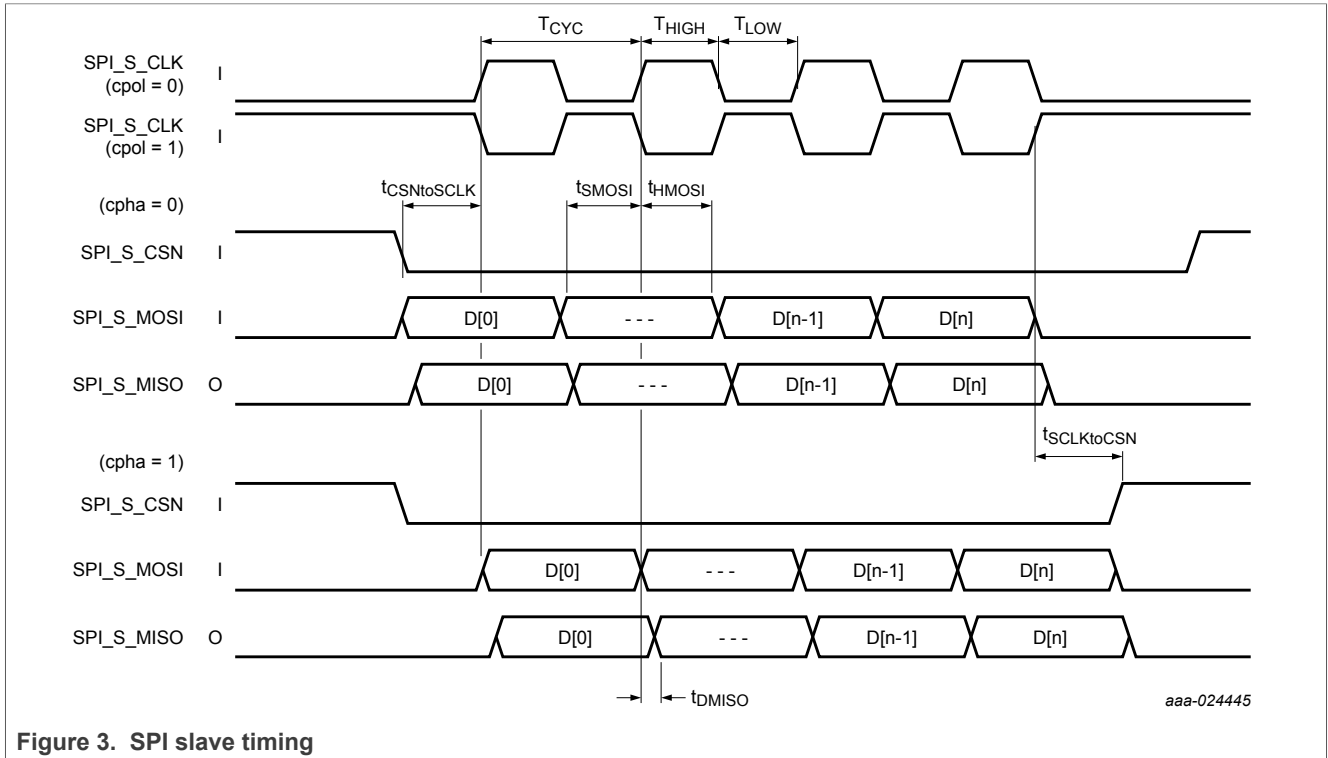

Figure 3. SPI slave timing

Write operations of NXH3670UK SPI slave interface can be done with a clock frequency of 16 MHz. However, for read operations in the final application, the MISO output delay can impact the performances.

Table 12. SPI slave timing for V_{IO} = 1.20 V

Symbol	Parameter	Conditions	Min	Typ	Max	Unit
T _{CYC}	clock cycle time	V _{IO} = 1.20 V, C _{out} = 15 pF	62.5	-	-	ns
T _{HIGH}	clock HIGH time as a percentage of T _{CYC}		45	-	55	%
T _{LOW}	clock LOW time as a percentage of T _{CYC}		45	-	55	%
t _{SMOSI}	MOSI setup time		12.5	-	-	ns

Table 12. SPI slave timing for $V_{IO} = 1.20\text{ V}$...continued

Symbol	Parameter	Conditions	Min	Typ	Max	Unit
t_{HMOSI}	MOSI hold time		12.5	-	-	ns
t_{DMISO}	MISO output delay	$V_{IO} = 1.20\text{ V}$, $C_{out} = 15\text{ pF}$, drive strength = HIGH	-	-	30	ns
$t_{CSNtoSCLK}$	chip select LOW to clock		15	-	-	ns
$t_{SCLKtoCSN}$	clock to chip select HIGH		15	-	-	ns

Table 13. SPI slave timing for $V_{IO} = 1.80\text{ V}$

Symbol	Parameter	Conditions	Min	Typ	Max	Unit
T_{CYC}	clock cycle time	$V_{IO} = 1.80\text{ V}$, $C_{out} = 15\text{ pF}$	62.5	-	-	ns
T_{HIGH}	clock HIGH time as a percentage of T_{CYC}		45	-	55	%
T_{LOW}	clock LOW time as a percentage of T_{CYC}		45	-	55	%
t_{SMOSI}	MOSI setup time		12.5	-	-	ns
t_{HMOSI}	MOSI hold time		12.5	-	-	ns
t_{DMISO}	MISO output delay	$V_{IO} = 1.80\text{ V}$, $C_{out} = 15\text{ pF}$, drive strength = HIGH	-	-	26	ns
$t_{CSNtoSCLK}$	chip select LOW to clock		15	-	-	ns
$t_{SCLKtoCSN}$	clock to chip select HIGH		15	-	-	ns

Table 14. SPI slave timing for $V_{IO} = 2.50\text{ V}$

Symbol	Parameter	Conditions	Min	Typ	Max	Unit
T_{CYC}	clock cycle time	$V_{IO} = 2.50\text{ V}$, $C_{out} = 15\text{ pF}$	62.5	-	-	ns
T_{HIGH}	clock HIGH time as a percentage of T_{CYC}		45	-	55	%
T_{LOW}	clock LOW time as a percentage of T_{CYC}		45	-	55	%
t_{SMOSI}	MOSI setup time		12.5	-	-	ns
t_{HMOSI}	MOSI hold time		12.5	-	-	ns
t_{DMISO}	MISO output delay	$V_{IO} = 2.50\text{ V}$, $C_{out} = 15\text{ pF}$, drive strength = HIGH	-	-	25	ns
$t_{CSNtoSCLK}$	chip select LOW to clock		15	-	-	ns
$t_{SCLKtoCSN}$	clock to chip select HIGH		15	-	-	ns

7.2.4 UARTs

Depending on the selected IO switch matrix configuration (see [Section 7.2.11](#)), a UART interface is made available externally.

They are used for debug and testing purposes and are not available for interfacing with a Host. They can for instance be used by the ARM Cortex-M0 or the CoolFlux audio DSP for logging purposes.

More information about configuration parameters of UART interfaces can be found in [Table 15](#).

Table 15. UART configuration parameters

Property	Value
character width	8 bit
stop bits	1 bit
parity	no parity
flow control	no flow control
baud rate	888888

7.2.5 Dataport (I²S or TDM)

The dataport is used for audio transmission between the NXH3670UK and a host or a codec. The dataport can be configured in I²S or TDM mode. The dataport uses the same four lines for both I²S and TDM ([Table 16](#)).

Table 16. Dataport signals

Signal name	Description
I2S_WS	word select, indicating which channel is being transferred
I2S_CLK	bit clock, synchronizing all devices on the bus
I2S_SI	input data line (regarding the NXH3670UK)
I2S_SO	output data line (regarding the NXH3670UK)

The following configuration options are available:

- I²S slave mode at 48 kHz
- Interface word length (common value for both input and output channels): 16 bits or 32 bits (left-justified with zero padding)
- I²S master mode supporting 50 kHz
- TDM slave mode supporting 2, 4, or 8 channels. The interface word length can be either 16 bits or 32 bits for 2 and 4 channels. The interface word length is limited to 16 bits for 8 channels.

Unused output channels can be tristated. The maximum bit rate is 6.2 Mbps. More information on the TDM interface can be found in the "NXH3670 TDM audio interface specification" application note ([Ref. 3](#)).

7.2.6 Clock shop

The clock shop modules provide the necessary clocks for the ARM Cortex-M0 and all the other modules in the wireless link controller. Each module has its own clock or clocks, generated by the clock shop. Each clock individually has the following settings:

- Clock source
- Enable/disable
- Division factor

For the clocks to be reprogrammed in a safe way (such that no spikes occur on the clock signal), the parameters have to be programmed in a certain order. For all clocks, it is recommended to disable the clock before changing the divider setting. The ARM Cortex-M0 clock itself is a special case, since it cannot be switched off or the system would lock up. For this reason, the parameter updates for this block are synchronized with the running clock during update.

Clock switching is glitch free for modules that require clock switching in active mode. These modules are:

- The ARM Cortex-M0
- The HSI bus
- The G.722 codecs
- The CoolFlux audio DSP

The clock shop can be programmed via software API by the ARM Cortex-M0.

The clock shop module also contains a calibration function. This function can be used to adjust the internal RC oscillator frequencies by comparing them with the 16 MHz/32 MHz crystal oscillator clock.

7.2.7 Timers

The NxH3670UK contains two identical hardware timer modules. Each timer module is a 16-bit interval timer with 3 independent capture/compare registers.

7.2.8 Audio processing

The wireless link controller contains the following modules for audio processing: G.722 codec instance, sample rate converter, audio latency control instance, and the CoolFlux audio DSP.

7.2.8.1 G.722 codec

The audio codec hardware module has the following specifications:

- 2 contexts, each context can independently encode/decode an audio stream
- Supported mode is subband ADPCM according to ITU-T G.722 mode 1

Typical sample rate of G.722 compression is 16 kHz but it can be used up to 48 kHz.

7.2.8.2 Latency control

The latency control hardware module controls the end-to-end audio latency across the wireless link to a programmable value. This control is especially important for synchronous streams (for example left/right audio channel) where it is mandatory to

achieve the same audio latency. The latency control hardware module contains timers and an NCO, which are steered to maintain the configured audio latency.

7.2.8.3 CoolFlux audio DSP

The CoolFlux audio DSP is a hardware audio accelerator used to implement audio functions such as audio compression/decompression codecs, equalization, and audio mixing. It is designed to work typically at 16 MHz or a lower frequency, but can run at a frequency up to 84 MHz in the configuration where an external regulator is used.

A test and debug interface, available on SWM IO through configuration is also provided.

The CoolFlux audio DSP subsystem is connected to the HSI data bus through a DMA engine, which can handle up to 8 independent queues. This DMA engine can reach the program memory and both X and Y data memories.

The CoolFlux audio DSP can access the APB bus via the APB memory bridge, through an APB arbiter. Conversely, the Cortex-M0 has access to CoolFlux IO register map, also via the APB memory bridge.

The boot loader running on the Cortex-M0 core loads the CoolFlux DSP program images from an external device, typically the host MCU. The loading is performed through the DMA interface, while holding the DSP in reset.

Amount of X and Y memories is configurable at startup from a fixed pool of ROM and RAM.

[Table 17](#) indicates the sizes of the different memories:

Table 17. CoolFlux memories

Memory	Value
P-RAM size	8 K × 32 bit [32 kB]
P-ROM size	16 K × 32 bit [64 kB]
RAM pool (X and Y) size	20 K × 24 bit [60 kB]
ROM pool (X and Y) size	10 K × 24 bit [30 kB]

7.2.9 Random number generator (RNG)

The Random number generator (RNG) is a true random number generator to be used for security purposes. It takes multiple clock sources as input to provide a random number on request.

7.2.10 RF HWMAC accelerator

The RF HWMAC accelerator implements the medium access control (MAC) layer of the radio. The MAC consists of:

- RFMAC controller
- Configuration interface toward the RF modem and RF radio
- DMA engine with 4 channels for interfacing with HSI bus and Cortex-M0

- Radio data path
 - Up to 4 configuration banks for TX and 4 configuration banks for RX
 - Packet assembly, disassembly (address, header, payload)
 - CRC accelerator
 - Whitening accelerator
 - AES security accelerator
 - Off-line encryption/decryption of payload data using API control
 - On-the-fly encryption/decryption of Bluetooth Low Energy payload data
 - Accurate timers for packet timing

7.2.10.1 External PA control

The following signals, available through the switch matrix, provide external PA support:

- PA enable
- RX enable

7.2.11 Versatile IO switch matrix

This module allows connection of the various functional signals to a limited set of actual chip IO pins. The switch matrix pad voltage is referenced to VIO.

During reset (POR_RESETN), SWM pins are in 3-state.

[Table 18](#) gives an overview of the functionalities that are multiplexed on each of the SWM pins:

Table 18. Versatile switch matrix

Pin	Default	Configuration A ^[1]	Configuration B ^[1]	Configuration C ^[1]	Configuration D ^[1]
SWM00	SPI_S_MISO (output)	SPI_S_MISO (output)	SPI_S_MISO (output)	SPI_S_MISO (output)	SPI_S_MISO (output)
SWM01	SPI_S_MOSI (input)	SPI_S_MOSI (input)	SPI_S_MOSI (input)	SPI_S_MOSI (input)	SPI_S_MOSI (input)
SWM02	SPI_S_CLK (input)	SPI_S_CLK (input)	SPI_S_CLK (input)	SPI_S_CLK (input)	SPI_S_CLK (input)
SWM03	SPI_S_CSN (output)	SPI_S_CSN (output)	SPI_S_CSN (output)	SPI_S_CSN (output)	SPI_S_CSN (output)
SWM04	SPI_S_INT (output)	SPI_S_INT (output)	SPI_S_INT (output)	SPI_S_INT (output)	SPI_S_INT (output)
SWM05 ^[2]	(3-state)	(3-state)	(3-state)	I2S_SO (output)	(3-state)
SWM06 ^[2]	(3-state)	I2S_SI (input)	I2S_SI (input)	I2S_SI (input)	UART_RXD (input)
SWM07 ^[2]	(3-state)	I2S_SO (output)	I2S_SO (output)	UART_TXD (output)	UART_TXD (output)
SWM08 ^[2]	(3-state)	UART_TXD (output)	EXT_RXEN(CRX) (output)	EXT_RXEN(CRX) (output)	EXT_RXEN(CRX) (output)
SWM09 ^[2]	(3-state)	UART_RXD (input)	EXT_PAEN(CTX) (output)	EXT_PAEN(CTX) (output)	EXT_PAEN(CTX) (output)

Table 18. Versatile switch matrix...continued

Pin	Default	Configuration A ^[1]	Configuration B ^[1]	Configuration C ^[1]	Configuration D ^[1]
SWM10 ^[2]	(3-state)	I2S_CLK (input)	I2S_CLK (input)	I2S_CLK (input)	(3-state)
SWM11 ^[2]	(3-state)	I2S_WS (input)	I2S_WS (input)	I2S_WS (input)	(3-state)
SRQ	SPI_S_SRQ (input)	SPI_S_SRQ (input)	SPI_S_SRQ (input)	SPI_S_SRQ (input)	SPI_S_SRQ (input)

[1] The configuration of A,B,C, or D is performed by the host controller with an HCI SPI command just after booting the NXH3670.

[2] SWM pins 5 to 11 are only enabled after the host controller triggers the function with an HCI SPI command.

[Section 9.2](#) explains the default positions of SPI master and SPI slave during boot mode.

7.2.12 Power management unit (PMU)

7.2.12.1 General

The PMU module supports the following operating modes:

- Operation on external power regulator (1.2 V)

It provides regulated power supplies from the external voltage to supply:

- Radio subsystem
- Digital and memories

Under control of firmware, the PMU is able to optimize current consumption in each use case by enabling and controlling the supply of only the hardware blocks necessary for the use case.

The PMU also contains state machine that allows support of different low-power modes (see [Section 9](#)) and wake-up functionality. The wake-up can be triggered from the following sources:

- POR
- Low-power timer
- SRQ (service request) pin

In addition, it contains functionality for supply voltage monitoring, Power-on reset (POR) and to detect power dips (BOD). It also includes a persistent register file for configuration and trimming that is kept in all power modes.

7.2.12.2 Power-on reset (POR)

A power-on reset (POR) circuit ensures proper start-up of the chip. It comprises:

- A detector responsive to the presence (ramp-up) of the supply voltage VEXT
- A 50 ms delay circuit to stretch the POR signal. This delay is called TPOR. This delay is to ensure proper start-up of the chip after connection with a new voltage supply which can bounce.

The POR module is always enabled. A reset generated by the POR module resets the complete IC, including the PMU.

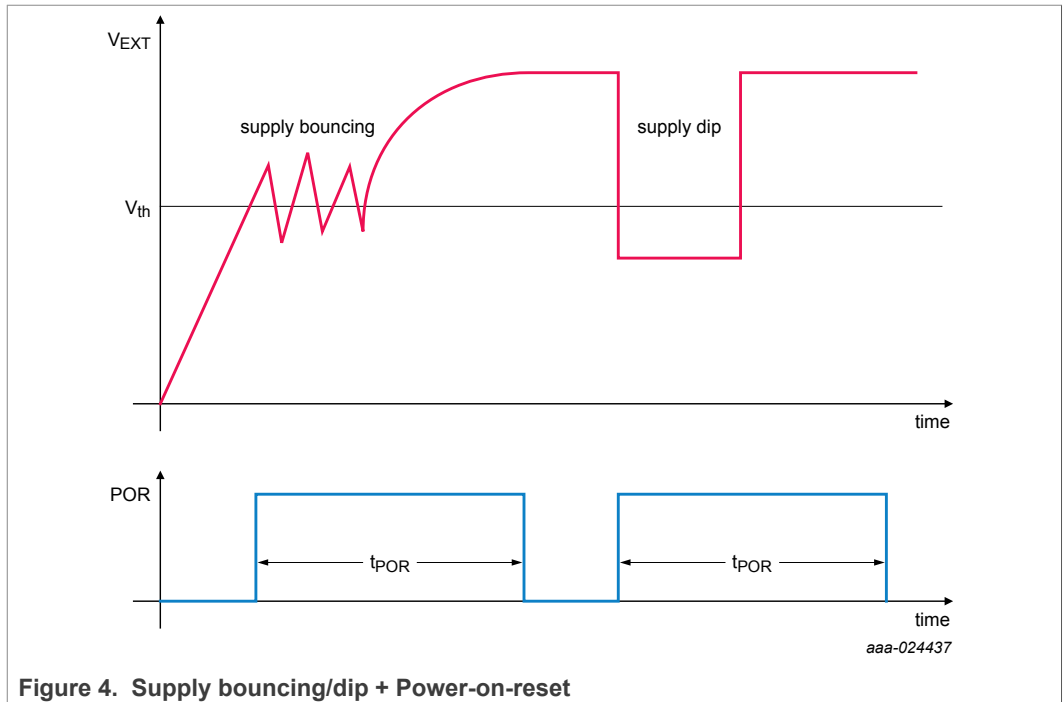

Figure 4. Supply bouncing/dip + Power-on-reset

When V_{EXT} drops below V_{POR} , the power-on reset circuit drives the RESETN signal LOW weakly to generate a clean reset signal to reset the PMU. The PMU prolongs the reset for t_{POR} to reset the rest of the chip. When not active, the power-on reset circuit is driving the RESETN signal weakly HIGH (see Figure 5).

An external device can override the power-on reset circuit and trigger a reset by driving the RESETN signal LOW. It is not allowed to drive the RESETN signal HIGH or to put an external pull resistor on the RESETN signal. A HIGH on RESETN prevents correct operation of the power-on reset circuit.

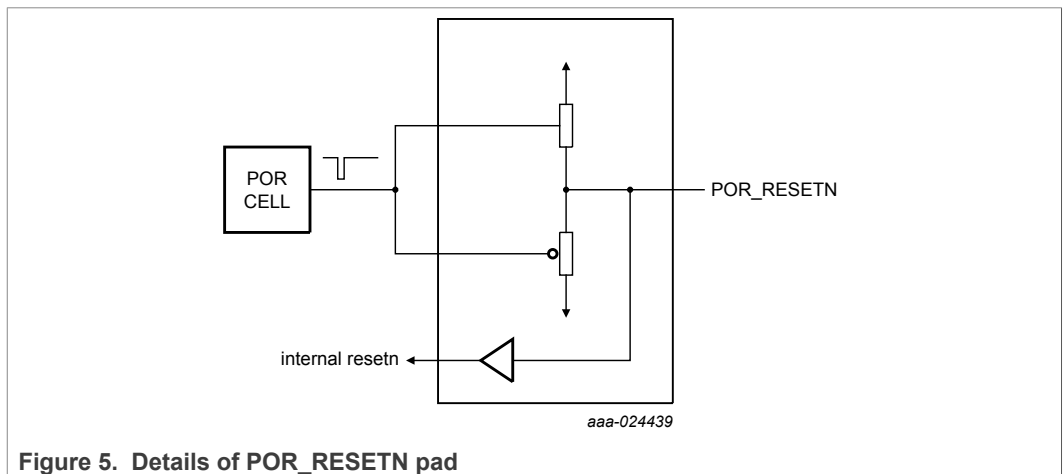

Figure 5. Details of POR_RESETN pad

Table 19. POR

Symbol	Parameter	Conditions	Min	Typ	Max	Unit
T_{POR}	POR stretching time		34	50	102	ms
V_{TH}	POR threshold	minimum $V_{EXT} = 0.8$ V, maximum $V_{EXT} = 1.45$ V	0.68	0.8	0.89	V

7.2.12.3 Brownout detection (BOD)

In addition to the POR protecting the power domain which is continuously on, the NXH3670UK also has Brownout detection (BOD) for internal supplies. The brownout threshold voltage can be programmed. Each brownout detector generates a signal that can force a POR.

The goal of the BOD cells is to protect the circuit against malfunctioning if dips on the supply voltage occur.

7.2.12.4 Persistent registers

The PMU also contains persistent registers. These registers are directly supplied from V_{EXT} so that their value is retained even when all other digital supplies are off.

These registers contain values that must be retained to allow restart from some low-power modes. The values that are stored here are configuration parameters and trimming values.

7.2.12.5 Clock generation

The NXH3670UK typically derives its internal clocks from a 16 MHz/32 MHz crystal oscillator. In some modes, in order to save power or to generate faster clock, the chip can also generate clocks from internal oscillators. LPOs at 16 MHz and 20 MHz, HFOs at 44 MHz and 84 MHz and ULPO/LJO at 400 kHz oscillators are provided. The internal oscillators can be trimmed from the crystal oscillator clock.

7.2.12.6 Crystal oscillator

An external crystal must be connected to the crystal oscillator pins (XIN, XOUT) in order to generate a clock for the NXH3670UK. Both 16 MHz and 32 MHz crystals are supported but internally the clock is 16 MHz.

The oscillator is provided with on-chip capacitors to remove the need for external load capacitors. A fraction of these capacitors is trimmable in order to adjust the frequency accuracy. The trimming is done through firmware during PCB assembly to get to the desired accuracy for the application.

The crystal oscillator is not enabled until the Cortex boots up; the control of the crystal remains under control of the firmware.

If a 16 MHz/32 MHz clock is already present in the application, this clock can be provided to the NXH3670UK through the XIN bump. However, to sustain RF performances (see [Table 22](#)), this clock must support the required characteristics.

If other devices want to slave from the NXH3670UK crystal, the crystal signal must be taken from the XIN bump. Constraints for this configuration can be found in [Table 23](#).

Table 20. 16 MHz crystal oscillator characteristics

Symbol	Parameter	Conditions	Min	Typ	Max	Unit
f_{XTAL}	crystal frequency		-	16	-	MHz
Δf_{XTAL}	crystal frequency tolerance ^[1]	untrimmed, including temperature and aging	-60	-	+60	ppm
C_L	crystal load capacitance		8	10	12	pF
C_0	crystal static capacitance		-	1.5	7	pF
R_{L-16}	crystal series resistance - 16 MHz		-	-	200	Ω
L_{S-16}	equivalent crystal serial inductance - 16 MHz		-	-	90	mH
T_{XTAL}	crystal oscillator settling time ^[2]		0.8	1.5	2.5	ms
$f_{noise16M}$	phase noise characteristics for 16 MHz crystal frequency	offset from carrier at 10 kHz	-	-130	-	dBc/Hz
		offset from carrier at 100 kHz	-	-136	-	dBc/Hz

[1] To support a 1 Mbps data rate in NxH-C mode, a ± 50 ppm accuracy is needed.
 [2] Settling time depends on crystal parameters. Typical value based on 8 pF/60 mH/100 Ω .

Table 21. 32 MHz crystal oscillator characteristics

Symbol	Parameter	Conditions	Min	Typ	Max	Unit
f_{XTAL}	crystal frequency		-	32	-	MHz
Δf_{XTAL}	crystal frequency tolerance ^[1]	untrimmed, including temperature and aging	-60	-	+60	ppm
C_L	crystal load capacitance		6	10	12	pF
C_0	crystal static capacitance		-	1.5	7	pF
R_{L-32}	crystal series resistance - 32 MHz		-	-	100	Ω
L_{S-32}	equivalent crystal serial inductance - 32 MHz		-	-	45	mH
T_{XTAL}	crystal oscillator settling time ^[2]		0.8	1.5	2.5	ms
$f_{noise32M}$	phase noise characteristics for 32 MHz crystal frequency	offset from carrier at 10 kHz	-	-124	-	dBc/Hz
		offset from carrier at 100 kHz	-	-130	-	dBc/Hz

[1] To support a 1 Mbps data rate in NxH-C mode, a ± 50 ppm accuracy is needed.
 [2] Settling time depends on crystal parameters. Typical value based on 8 pF/30 mH/100 Ω .

Table 22. 16 MHz/32 MHz Input clock characteristics when external crystal is provided to XIN

Symbol	Parameter	Conditions	Min	Typ	Max	Unit
f_{CLK}	crystal frequency		-	16/32	-	MHz
Δf_{CLK}	accuracy		-20	-	+20	ppm
V_{PP}	input clock amplitude	peak to peak voltage (sine wave)	500	-	800	mV
$f_{noise16M}$	phase noise characteristics for 16 MHz crystal frequency	offset from carrier at 10 kHz	-	-130	-	dBc/Hz
		offset from carrier at 100 kHz	-	-136	-	dBc/Hz

Table 22. 16 MHz/32 MHz Input clock characteristics when external crystal is provided to XIN...continued

Symbol	Parameter	Conditions	Min	Typ	Max	Unit
f _{noise32M}	phase noise characteristics for 32 MHz crystal frequency	offset from carrier at 10 kHz	-	-124	-	dBc/Hz
		offset from carrier at 100 kHz	-	-130	-	dBc/Hz

Table 23. 16 MHz/32 MHz clock characteristics when external host loads from XIN

Symbol	Parameter	Conditions	Min	Typ	Max	Unit
f _{CLK}	crystal frequency		-	16/32	-	MHz
C _L	XIN pin load		-	-	5 ^[1]	pF
V _{PP}	output clock amplitude	peak-to-peak voltage (sine wave)	^[2] -	200	-	mV

[1] Depending on used crystal

[2] Output amplitude is configurable by firmware. The swing has impact on current consumption and phase noise. Full swing is needed in order to meet radio performance.

7.2.13 One-time programmable (OTP) memory

The OTP holds trimming values for the PMU and RF. Programming of those bits is done during chip production.

8 Debugging and testing facilities

8.1 UART

The NXH3670UK features a complete UART interface which both the ARM Cortex-M0 and the CoolFlux DSP can use. More information about configuration parameters of UART interfaces can be found in [Table 15](#).

As well as this complete UART interface, the CoolFlux DSP has a dedicated TX-only UART for logging purposes

UARTs are available on SWM IOs according to [Table 18](#).

9 Start-up and power modes

9.1 Booting procedure

9.1.1 Power supply sequence

To prevent leakage current via I/Os of NXH3670UK and undefined state of the SWMs, V_{IO} should not be enabled before V_{EXT}. V_{IO} is enabled preferably at the same time as or later than V_{EXT}.

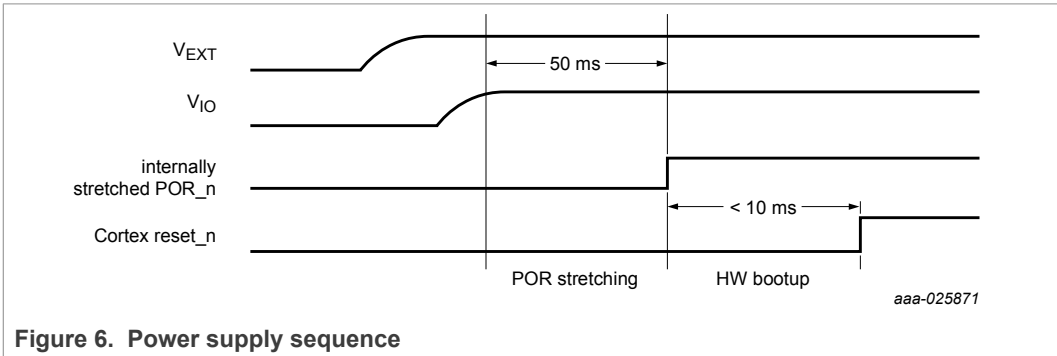

Figure 6. Power supply sequence

9.1.2 Boot loader

The boot loader is the default ROM code which is executed by the ARM Cortex M0 after a POR. The boot loader brings the IC in the 'active user mode' as shown in Figure 7. The boot loader in SPI Command Handler exposes command over SPI in order to load an image.

More information of the functionality can be found in Section 9.2.

Detailed boot loader commands can be found in the "NXH3670UK boot loader" document (Ref. 2).

9.1.3 Boot time

The boot time depends on several factors that are system and user application specific:

- Size of the firmware to be downloaded
- Speed of the SPI interface
- Maximum current allowed by the application (possibly limiting the speed of the SPI interface)

There is also a fixed time at start-up before the real boot procedure can start. This time includes POR reset, configuration, and start-up of the supplies and the clock. This time is less than 60 ms, considering a POR delay of 50 ms.

9.2 State diagram

Figure 7 shows how the NXH3670UK starts up and switches between different states. The sections below describe the different states and how the system switches between them. The different states are:

- Reset
- Init
- SPI command handler
- Active user mode
- SLEEP

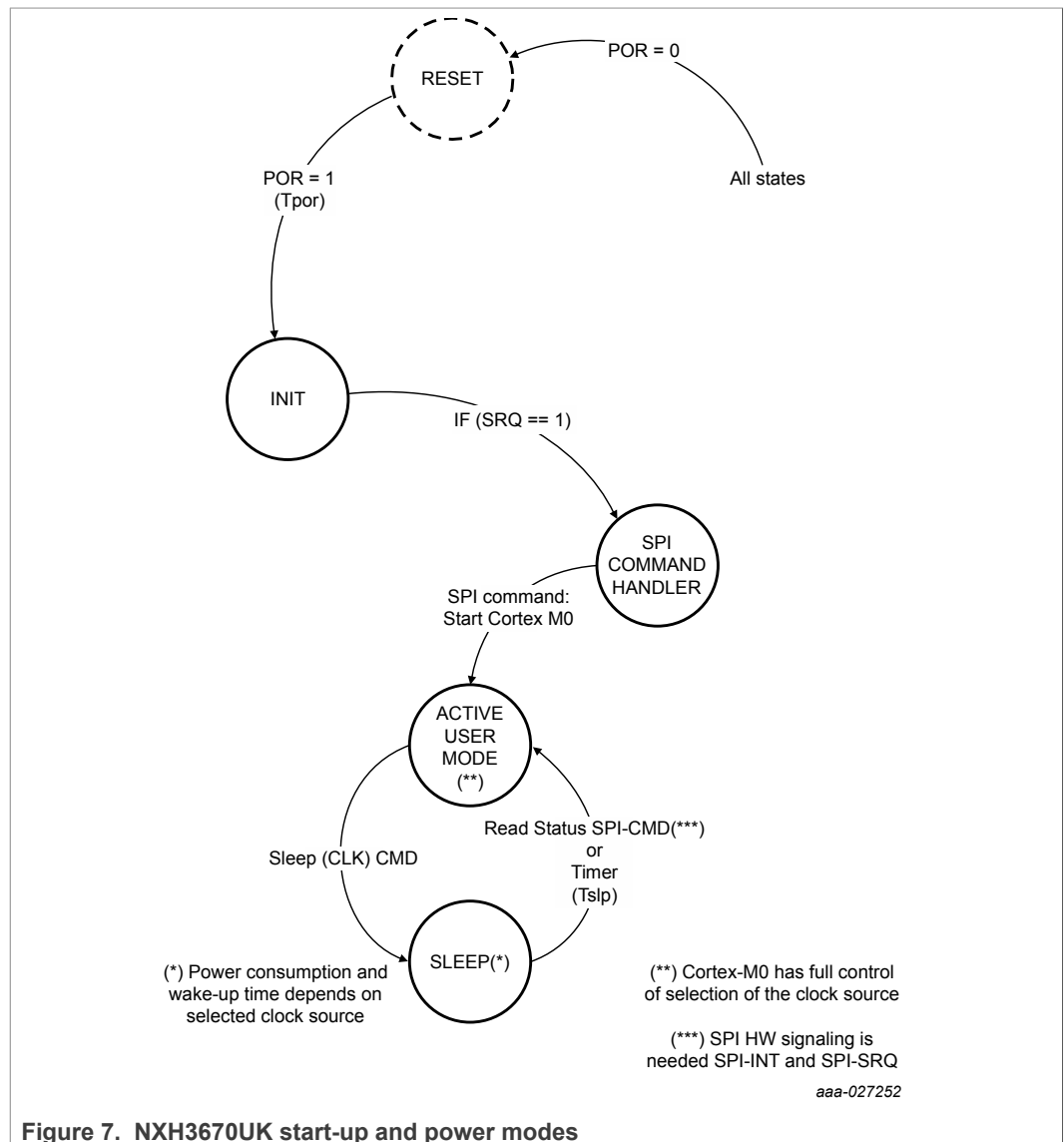

Figure 7. NXH3670UK start-up and power modes

9.2.1 Reset (undefined)

This state is the default state of the chip when the supply is connected. The full chip is OFF, with the core kept in a stable state by the POR cell.

All the functions in the chip are off or disabled. Only the POR cell is active.

This state can be entered from all other state for different reasons:

- Supply voltage going below the minimum level
- BOD event (impact of BOD event is configurable by API after start-up)
- Firmware generated reset

As a POR state transition can be generated from all states, it is not repeated as possible state transition in the sections below.

When the power-on reset cell has settled, the chip can start up and enter the INIT state.

9.2.2 Init

The init state configures the NXH3670UK for correct operation. This state can only be entered from the reset state. The supply voltage is measured and the PMU configures the different supply generation blocks to the right settings. The trimming and functional configuration settings are loaded from OTP. To keep the current consumption low in this state, most of the digital logic remains inactive.

The Cortex works from the on-chip 16 MHz LPO oscillator clock in the Init state.

The NXH3670UK checks the status of the SRQ (service request) input pin.

- If SRQ = logic 0, the NXH3670UK stays in the init state
- If SRQ = logic 1, the NXH3670UK enters the SPI command handler state

9.2.3 SPI command handler

During this state, the MCU system is started and the boot loader firmware is executed from ROM to enable firmware download.

The NXH3670UK is slave of the host and download is started and executed through SPI commands

The following steps are performed:

- SPI slave interface is enabled by default using:
 - SMW00: SPI_S_MISO
 - SMW01: SPI_S_MOSI
 - SMW02: SPI_S_CLK
 - SMW03: SPI_S_CS
- Based on a set of SPI commands, the host can download an image into the ARM Cortex-M0 memory
- When the firmware download is completed, the NXH3670UK moves to active user mode state upon receiving an SPI command

Following functionality is provided to the host controller based on SPI commands:

- Read & Write ARM memory:
The host is able to read and write ARM memory.
- Read & Write CoolFlux memory:
The host is able to read and write CoolFlux program and data memory.
- Initialize/Disable CoolFlux:
The host can enable and disable the CoolFlux DSP.
- Start application:
The host is able to force the boot loader to start execution from a given ARM-program-memory location.
- Get version:
The host can retrieve the version of the boot loader and the hardware.
- Reset command:
The host can trigger a reset of the device.
- Reinitialize SWM:
The host can reconfigure the SWM.

9.2.4 Active user mode

In this state, the NXH3670UK can activate all blocks and run all necessary activities for the application. RF transmission and reception, audio processing, link control, SPI transfers are all done in active user mode state

Generally, the system only stays in this mode during the real period of activity. When this activity is finished, it switches to the sleep state. However, even in this mode the current consumption is minimized by stopping the clock and the supply to the blocks which are not active.

This state can be entered from the SPI command handler state after firmware download or from the sleep state when the chip wakes up.

The system can enter the sleep state based on a dedicated MCU command.

In the active user mode state, the SPI_S_SRQ and SPI_S_INT must be used for signaling from the host to the NXH3670UK.

9.2.5 Sleep

The sleep state is the low-power mode state. To reduce current consumption, this state is used as much as possible between periods of activity of the chip. It allows the quickest restart as the full state of the chip is kept.

In this state, the digital logic that must retain its state is kept supplied. All the unnecessary clocks are stopped and the MCU are in idle state. Typically, the system runs on ULPO or LJO¹ but the firmware can decide to keep other clocks active (for example, the XTAL clock). Because the current consumption depends on the clocks and blocks that are requested to stay active by the MCU, it is variable in this state. However, most of the time the leakage of the digital logic and the clock generation determines the current consumption.

This state is entered from the active user mode state through a Cortex MCU sleep command.

The system can go back to the active user mode state based on interrupt, typically coming from an SPI read status command or a timer event.

¹ Applications using ULPO/LJO as sleep timer clock must consider the drift in frequency caused by a change in temperature or VEXT supply.

10 Current consumption

[Table 24](#) shows the NxH3670UK current consumption for different modes of operation. The conditions for the current values are given in the table. For the low-power modes and for the radio modes, the current is typically constant. For the use cases, the value given is an average of the current consumption over multiple periods of RF activity.

All values are measured on reference board for typical process at 1.2 V and 25 °C. They do not include the current from V_{IO} as it depends on activity, switch matrix configuration, and application board load.

The NxH3670UK uses the high-performance (HP) mode.

Table 24. Current consumption

Mode/Use case	Conditions	HP	Unit
SLEEP ^[1]	ULPO active and Cortex retention	63	μA
	LJO active and Cortex retention (incremental) LJO frequency is 650 kHz	10	μA
	CoolFlux memory retention (incremental)	10	μA
XTAL oscillator 32 MHz	Includes RF band gap and XTAL LDO ^[2]	115	μA
Start-up	maximum current during start-up, from POR to the active user mode state	< 4	mA
Active	Cortex active baseline current. XTAL oscillator not included	950 ^[3]	μA
	audio subsystem baseline (incremental)	155	μA
	CoolFlux memory active (incremental)	110	μA
Cortex	processor and memory only, excluding leakage and static clock tree consumption. Radio and audio inactive.		
	WFI	17	μA/MHz
	while-1 loop	76	μA/MHz
CoolFlux	processor and memory only, excluding leakage and static clock tree consumption.		
	idle	8	μA/MHz
	SBC encoding	61	μA/MHz
Audio HW	dataport in 16 kHz – coder – decoder – ASRC – dataport out. Not including V_{IO} current (use case dependent). (excluding leakage and static clock tree consumption)	90	μA
Radio activation		404	μA
	after that XTAL settles	0.162	ms

Table 24. Current consumption...continued

Mode/Use case	Conditions	HP	Unit
Radio RX	ramp-up current including RFMAC and RFPHY but not Cortex. All radio modes	1.25	mA
	ramp-up time	0.12	ns
	active current including RFMAC and RFPHY but not Cortex, All radio modes	4.0	mA
Radio TX	ramp-up current including RFMAC and RFPHY but not Cortex. All radio modes	1.25	mA
	ramp-up time	0.12	ms
	active current at -10 dBm, including RFMAC and RFPHY but not Cortex. All radio modes, Ideal load presented to RF antenna bumps	3.7	mA
	active current at 0 dBm, including RFMAC and RFPHY but not Cortex. All radio modes. Ideal load presented to RF antenna bumps	7.2	mA
	active current at 4 dBm, including RFMAC and RFPHY but not Cortex. All radio modes. Ideal load presented to RF antenna bumps	13.4	mA

- [1] The XTAL oscillator current consumption must also be included for sleep mode calculations.
- [2] Murata XRCMD32M000FXP52R0 crystal (recommended).
- [3] This number includes static power consumption of the 84 MHz FRO

11 Limiting values

Table 25. Limiting values

In accordance with the Absolute Maximum Rating System (IEC 60134).

Symbol	Parameter	Conditions	Min	Max	Unit
V _{EXT,MAX}	supply voltage	applying to all supplies connected to the V _{EXT}	-0.5	+1.5566	V
V _{IO,MAX}	IO Pad voltage	fail-safe operation between minimum and maximum values.	-0.3	+2.7	V
P _{TOT}	total power consumption		-	1	W
T _{JUNCT}	junction temperature		-40	+125	°C
T _{STO}	storage temperature		-40	+150	°C
RH	operating humidity range	[1]	-	95	%
V _{ES}	electrostatic handling voltage	human body model (HBM) ^[2]			
		all pins	-	2000 ^[3]	V
		charged device model (CDM) ^[4]			
		all pins	-	500 ^[5]	V

[1] MSL - Moisture Sensitivity Level - JEDEC J-STD-20D - maximum level 3 (168 hours floor life at ≤ 30 °C and 60 % relative humidity)

[2] Equivalent to discharging a 100 pF capacitor through a 1.5 kΩ series resistor (human body model) compliant with JESD22-A115-AJS-001-2014 norm.

[3] JEDEC document JEP155 states that 500 V HBM allows safe manufacturing with a standard ESD control process

[4] Only applied to integrated component, Compliant with JESD22-C101-AC101F norm.

[5] JEDEC document JEP157 states that 500 V HBM allows safe manufacturing with a standard ESD control process

12 Electrical characteristics

Table 26. Electric and environmental characteristics

Symbol	Parameter	Conditions	Min	Typ	Max	Unit
T_{AMB}	operating temperature range		-20	+25	+85	°C
V_{EXT}	external regulator	maximum current is limited to 9 mA for digital and 6 mA for memories.	1.14	1.2	1.26	V
V_{NOISE}	external supply voltage noise	from external supply, up to 20 kHz	-	-	150	mVpp
V_{IO}	IO supply voltage	$V_{IO} \geq V_{EXT}$	1.14	-	2.7	V
V_{IL}	input level LOW	percentage of V_{IO} ; SWM pads	-	-	30	%
V_{IH}	input level HIGH	percentage of V_{IO} ; SWM pads	70	-	-	%
V_{OL}	output level LOW	percentage of V_{IO} ; at $I_{OL} = 2$ mA	-	-	20	%
V_{OH}	output level HIGH	percentage of V_{IO} ; at $I_{OH} = 2$ mA	80	-	-	%
I_{OL}	output drive capability LOW	API selectable speed mode: low, nominal, high; maximum 8 SSO	-	-	2	mA
I_{OH}	output drive capability HIGH	API selectable speed mode: low, nominal, high; maximum 8 SSO	-	-	2	mA
R_{pull}	pull-up resistor IO pins	tolerance < 20 %	-	50	-	kΩ
V_{t+}	Schmitt trigger rising threshold		0.7	-	-	V_{IO}
V_{t-}	Schmitt trigger falling threshold		-	-	0.3	V_{IO}
V_{HYS}	hysteresis voltage		$0.1 * V_{IO}$	$0.15 * V_{IO}$	-	V
t_r	IO rise time; $V_{IO} = 1.2$ V - 1 SSO; $C_L = 62$ pF ^[1]	low-speed mode	-	24	-	ns
		nominal-speed mode	-	12	-	ns
		high-speed mode	-	6	-	ns
t_f	IO fall time; $V_{IO} = 1.8$ V - 1 SSO; $C_L = 62$ pF ^[1]	low-speed mode	-	16	-	ns
		nominal-speed mode	-	12	-	ns
		high-speed mode	-	6	-	ns
C_p	bump capacitance	all digital IO pads	-	4	-	pF
C_L	load capacitance		^[2] -	15	100	pF

[1] Measured on reference board under typical conditions.

[2] High bump load may impact the speed of some interfaces.

13 Application information

To enable high-performance mode, all following application diagrams use external regulated supplies.

The NXH3670UK is delivered with precompiled binaries which are booted from the host controller (KL27 on SDK board or other). Based on the host API, the host controller controls these binaries over the SPI interface (see the SDK documentation for more information). These binaries constitute a complete application including power handling, radio configuration (e.g. pairing), and audio processing up to the I²S interface.

13.1 Headset application diagram

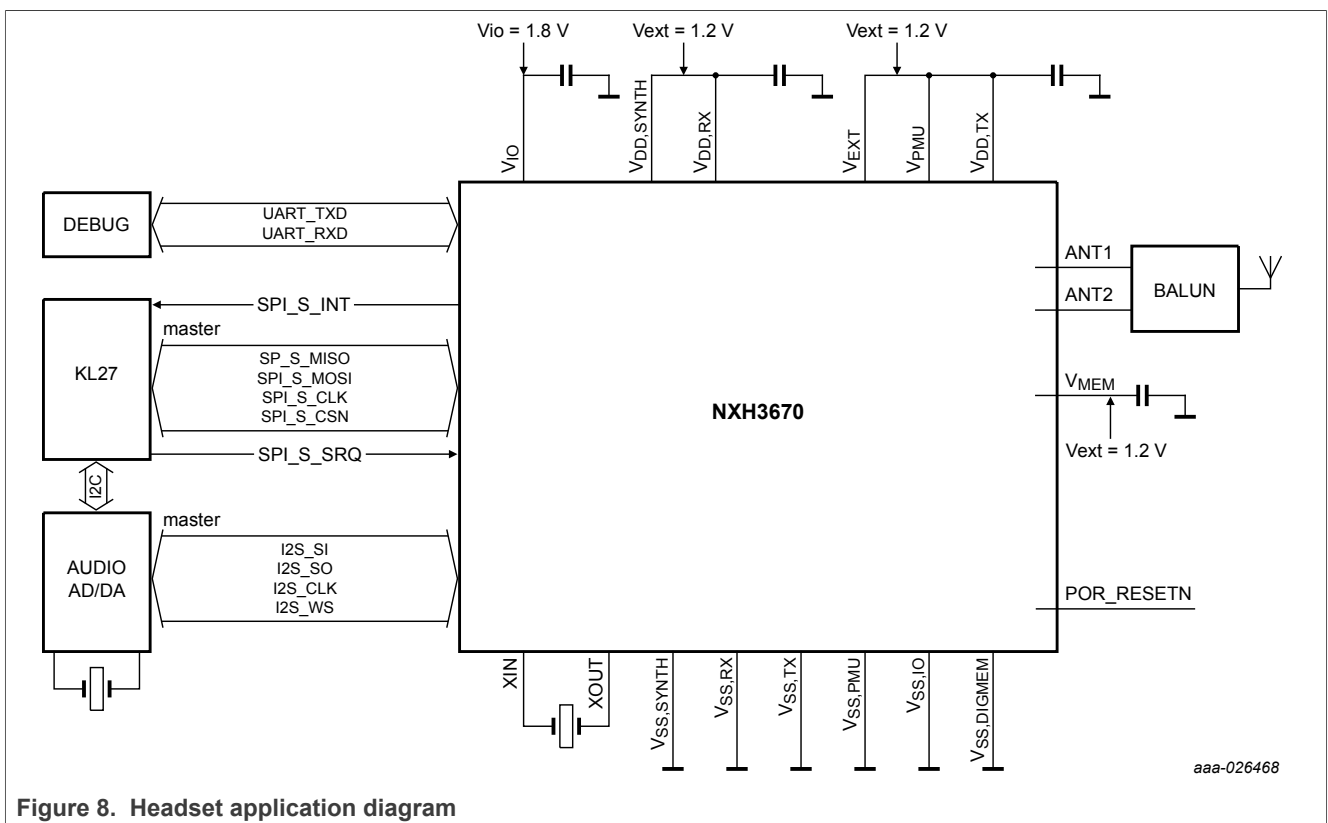

Figure 8. Headset application diagram

13.2 Dongle application diagram

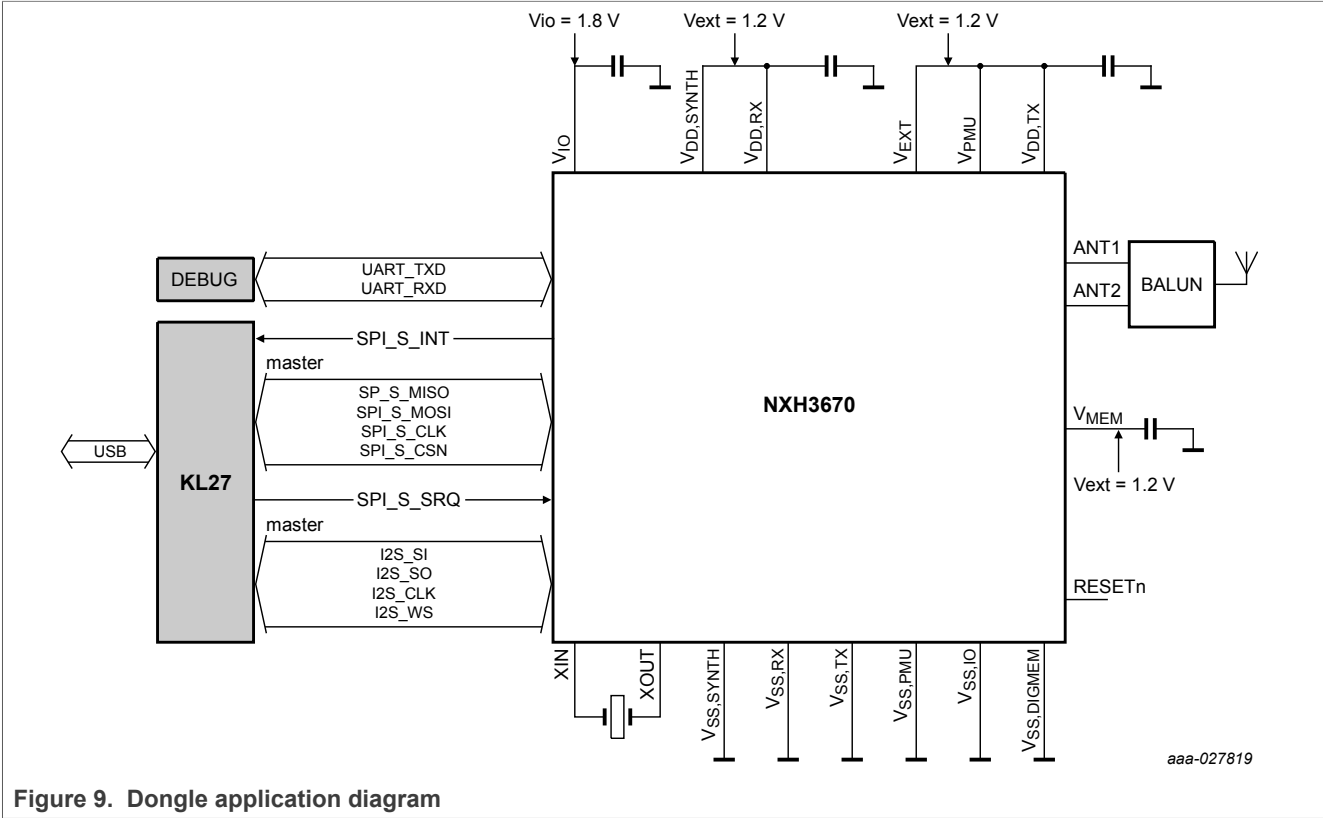

Figure 9. Dongle application diagram

13.3 External decoupling capacitors

The NXH3670UK design minimizes the requirement for external decoupling. All decoupling capacitors use 0201 package.

Table 27. Specification of decoupling capacitors

Supply	Typical value	Description
V _{PMU} V _{DD,TX} V _{EXT}	470 nF	common supply voltage decoupling
V _{DD,SYNTH} V _{DD,RX}	470 nF	common supply voltage decoupling
V _{IO}	470 nF	IO supply decoupling
V _{MEM}	470 nF	common supply voltage decoupling

13.4 PCB reliability

To ensure that board level reliability requirements are met, the application PCB must use underfill. It is the responsibility of the customer to validate board level reliability in the end application.

14 Package outline

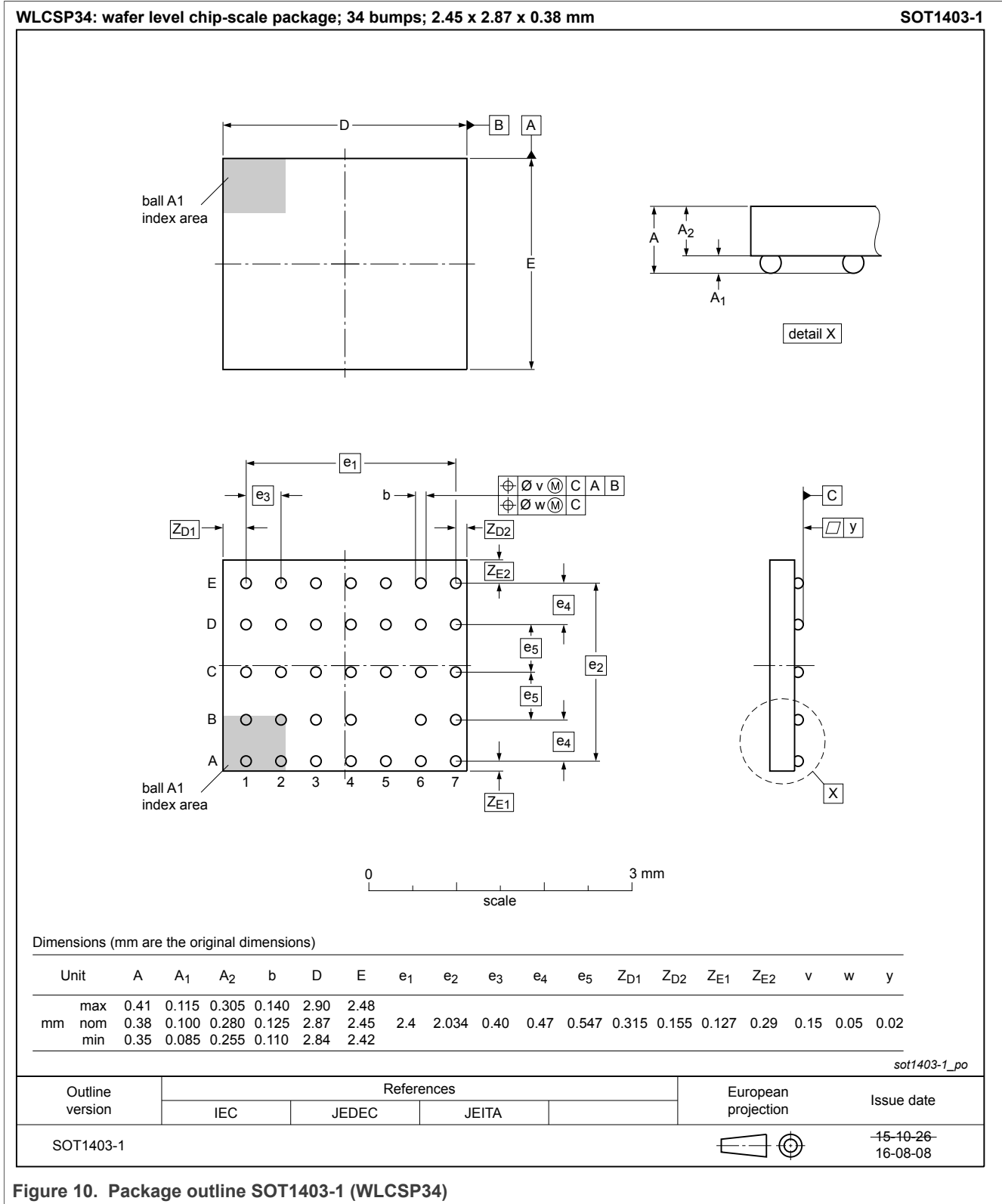

Figure 10. Package outline SOT1403-1 (WLCSP34)

Bump material is Sn + Ag 1.8 %

15 Handling information

See [Ref. 1](#) for detailed instructions on handling, soldering and mounting WLCSP packaged devices.

16 Packaging information

Default packing for the NXH3670UK devices is tape and reel according to T1 taping orientation as depicted below.

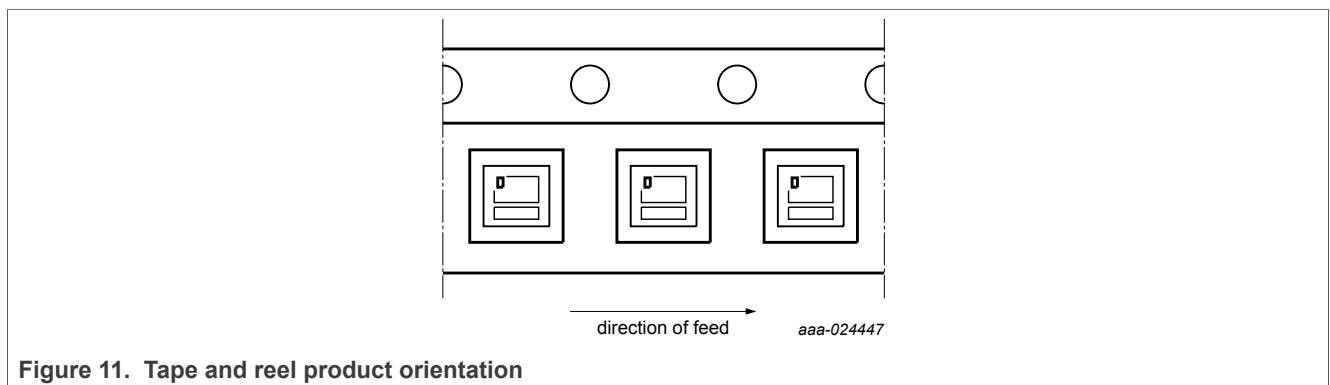

Figure 11. Tape and reel product orientation

17 Abbreviations

Table 28. Abbreviations

Abbreviation	Description
ACK	acknowledge
ADC	analog-to-digital converter
ADPCM	adaptive differential pulse code modulation
AES	Advanced Encryption Standard
APB	advanced peripheral bus
API	application program interface
ASIC	application specific integrated circuit
ASRC	asynchronous sample rate converter
BLE	bluetooth low energy
BOD	brownout detect
CDM	charged device model
CRC	cyclic redundancy check
CS	chip select
CSP	chip scale package
DAC	digital-to-analog converter
DS	data sheet
DMA	direct memory access
DSP	digital signal processor
DTU	data transfer unit
EEPROM	electrically erasable programmable read-only memory
FIFO	first-in-first-out
FPGA	field programmable gate array
GCC	GNU compiler collection
GFSK	gaussian frequency shift keying
GMSK	gaussian minimum shift keying
GPIO	general-purpose input output
HAL	hardware abstraction layer
HBM	human body model
HCI	host controller interface
HI	hearing instrument
HSI	high-speed interface
I2S	integrated interchip sound
ISR	interrupt service routine
ISV	independent software vendor

Table 28. Abbreviations...continued

Abbreviation	Description
JTAG	joint test action group
LFSR	linear feedback shift register
LDO	low drop out regulator
LJO	low jitter oscillator
MAC	medium access controller
MIS	medium integrity check
MISO	master-in-slave-out
MOSI	master-out-slave-in
NCO	numerically controlled oscillator
NVM	non-volatile memory
OS	operating system
OSAL	operating system abstraction layer
OPT	one time programmable
PCM	pulse code modulation
PHY	physical layer (of the radio subsystem)
PMC	power management controller
PMU	power management unit
PPM	parts per million
RDM	radio daughter module
RAM	random access memory
RF	radio frequency
RSSI	received signal strength indicator
SCL	serial clock
SDK	software development kit
SPI	serial peripheral interface
SR	service request
SSO	simultaneously switching outputs
SWB	software board
SWD	serial wire debug
SWM	switch matrix
UART	universal asynchronous receiver/transmitter
UBM	underbump Mmtallization
ULPO	ultra-low power oscillator
USB	universal serial bus
WLCSP	wafer level chip scale package

18 References

- [1] **AN11761 application note** — Flip-chip Rev. 3.0; 2016, NXP Semiconductors
- [2] **AN11953 application note** — NXH3670UK boot loader; 2017, NXP Semiconductors
- [3] **AN12937 application note** — NXH3670 TDM audio interface specification; 2020, NXP Semiconductors

19 Revision history

Document ID	Release date	Data sheet status	Change notice	Supersedes
NXH3670UK v.3.3	20201113	Product data sheet	-	NXH3670UK v.3.2
Modifications:	<ul style="list-style-type: none"> • Section 7.2.5 "Dataport (I²S or TDM)" has been updated. 			
NXH3670UK v.3.2	20191213	Product data sheet	-	NXH3670UK v.3.1
Modifications:	<ul style="list-style-type: none"> • Text and graphics have been updated throughout this document. 			
NXH3670UK v.3.1	20190725	Product data sheet	-	NXH3670UK v.3
Modifications:	<ul style="list-style-type: none"> • Section 7.2.5 "I²S (dataport)" has been updated; 32 bit wordlength added. 			
NXH3670UK v.3	20181029	Product data sheet	-	NXH3670UK v.2
Modifications:	<ul style="list-style-type: none"> • Section 7.2.5 "I²S (dataport)" has been updated. • Section 7.2.11 "Versatile IO switch matrix" has been updated. • Section 9.2.3 "SPI command handler" has been updated. • Section 9.2.4 "Active user mode" has been updated. • Section 13 "Application information" has been updated • Section 17 "Abbreviations" has been updated. 			
NXH3670UK v.2	20180302	Product data sheet	-	NXH3670UK v.1
NXH3670UK v.1	20171127	Product data sheet	-	-

20 Legal information

20.1 Data sheet status

Document status ^{[1][2]}	Product status ^[3]	Definition
Objective [short] data sheet	Development	This document contains data from the objective specification for product development.
Preliminary [short] data sheet	Qualification	This document contains data from the preliminary specification.
Product [short] data sheet	Production	This document contains the product specification.

[1] Please consult the most recently issued document before initiating or completing a design.

[2] The term 'short data sheet' is explained in section "Definitions".

[3] The product status of device(s) described in this document may have changed since this document was published and may differ in case of multiple devices. The latest product status information is available on the Internet at URL <http://www.nxp.com>.

20.2 Definitions

Draft — A draft status on a document indicates that the content is still under internal review and subject to formal approval, which may result in modifications or additions. NXP Semiconductors does not give any representations or warranties as to the accuracy or completeness of information included in a draft version of a document and shall have no liability for the consequences of use of such information.

Short data sheet — A short data sheet is an extract from a full data sheet with the same product type number(s) and title. A short data sheet is intended for quick reference only and should not be relied upon to contain detailed and full information. For detailed and full information see the relevant full data sheet, which is available on request via the local NXP Semiconductors sales office. In case of any inconsistency or conflict with the short data sheet, the full data sheet shall prevail.

Product specification — The information and data provided in a Product data sheet shall define the specification of the product as agreed between NXP Semiconductors and its customer, unless NXP Semiconductors and customer have explicitly agreed otherwise in writing. In no event however, shall an agreement be valid in which the NXP Semiconductors product is deemed to offer functions and qualities beyond those described in the Product data sheet.

20.3 Disclaimers

Limited warranty and liability — Information in this document is believed to be accurate and reliable. However, NXP Semiconductors does not give any representations or warranties, expressed or implied, as to the accuracy or completeness of such information and shall have no liability for the consequences of use of such information. NXP Semiconductors takes no responsibility for the content in this document if provided by an information source outside of NXP Semiconductors. In no event shall NXP Semiconductors be liable for any indirect, incidental, punitive, special or consequential damages (including - without limitation - lost profits, lost savings, business interruption, costs related to the removal or replacement of any products or rework charges) whether or not such damages are based on tort (including negligence), warranty, breach of contract or any other legal theory. Notwithstanding any damages that customer might incur for any reason whatsoever, NXP Semiconductors' aggregate and cumulative liability towards customer for the products described herein shall be limited in accordance with the Terms and conditions of commercial sale of NXP Semiconductors.

Right to make changes — NXP Semiconductors reserves the right to make changes to information published in this document, including without limitation specifications and product descriptions, at any time and without

notice. This document supersedes and replaces all information supplied prior to the publication hereof.

Suitability for use — NXP Semiconductors products are not designed, authorized or warranted to be suitable for use in life support, life-critical or safety-critical systems or equipment, nor in applications where failure or malfunction of an NXP Semiconductors product can reasonably be expected to result in personal injury, death or severe property or environmental damage. NXP Semiconductors and its suppliers accept no liability for inclusion and/or use of NXP Semiconductors products in such equipment or applications and therefore such inclusion and/or use is at the customer's own risk.

Applications — Applications that are described herein for any of these products are for illustrative purposes only. NXP Semiconductors makes no representation or warranty that such applications will be suitable for the specified use without further testing or modification. Customers are responsible for the design and operation of their applications and products using NXP Semiconductors products, and NXP Semiconductors accepts no liability for any assistance with applications or customer product design. It is customer's sole responsibility to determine whether the NXP Semiconductors product is suitable and fit for the customer's applications and products planned, as well as for the planned application and use of customer's third party customer(s). Customers should provide appropriate design and operating safeguards to minimize the risks associated with their applications and products. NXP Semiconductors does not accept any liability related to any default, damage, costs or problem which is based on any weakness or default in the customer's applications or products, or the application or use by customer's third party customer(s). Customer is responsible for doing all necessary testing for the customer's applications and products using NXP Semiconductors products in order to avoid a default of the applications and the products or of the application or use by customer's third party customer(s). NXP does not accept any liability in this respect.

Limiting values — Stress above one or more limiting values (as defined in the Absolute Maximum Ratings System of IEC 60134) will cause permanent damage to the device. Limiting values are stress ratings only and (proper) operation of the device at these or any other conditions above those given in the Recommended operating conditions section (if present) or the Characteristics sections of this document is not warranted. Constant or repeated exposure to limiting values will permanently and irreversibly affect the quality and reliability of the device.

Terms and conditions of commercial sale — NXP Semiconductors products are sold subject to the general terms and conditions of commercial sale, as published at <http://www.nxp.com/profile/terms>, unless otherwise agreed in a valid written individual agreement. In case an individual agreement is concluded only the terms and conditions of the respective agreement shall apply. NXP Semiconductors hereby expressly objects to applying the customer's general terms and conditions with regard to the purchase of NXP Semiconductors products by customer.

Ultra-low power 2.4 GHz Bluetooth Low Energy transceiver for audio streaming

No offer to sell or license — Nothing in this document may be interpreted or construed as an offer to sell products that is open for acceptance or the grant, conveyance or implication of any license under any copyrights, patents or other industrial or intellectual property rights.

Quick reference data — The Quick reference data is an extract of the product data given in the Limiting values and Characteristics sections of this document, and as such is not complete, exhaustive or legally binding.

Export control — This document as well as the item(s) described herein may be subject to export control regulations. Export might require a prior authorization from competent authorities.

Non-automotive qualified products — Unless this data sheet expressly states that this specific NXP Semiconductors product is automotive qualified, the product is not suitable for automotive use. It is neither qualified nor tested in accordance with automotive testing or application requirements. NXP Semiconductors accepts no liability for inclusion and/or use of non-automotive qualified products in automotive equipment or applications. In the event that customer uses the product for design-in and use in automotive applications to automotive specifications and standards, customer (a) shall use the product without NXP Semiconductors' warranty of the product for such automotive applications, use and specifications, and (b) whenever customer uses the product for automotive applications beyond NXP Semiconductors' specifications such use shall be solely at customer's own risk, and (c) customer fully indemnifies NXP Semiconductors for any liability, damages or failed product claims resulting from customer design and use of the product for automotive applications beyond NXP Semiconductors' standard warranty and NXP Semiconductors' product specifications.

Translations — A non-English (translated) version of a document is for reference only. The English version shall prevail in case of any discrepancy between the translated and English versions.

Security — Customer understands that all NXP products may be subject to unidentified or documented vulnerabilities. Customer is responsible for the design and operation of its applications and products throughout their lifecycles to reduce the effect of these vulnerabilities on customer's applications and products. Customer's responsibility also extends to other open and/or proprietary technologies supported by NXP products for use in customer's applications. NXP accepts no liability for any vulnerability. Customer should regularly check security updates from NXP and follow up appropriately. Customer shall select products with security features that best meet rules, regulations, and standards of the intended application and make the ultimate design decisions regarding its products and is solely responsible for compliance with all legal, regulatory, and security related requirements concerning its products, regardless of any information or support that may be provided by NXP. NXP has a Product Security Incident Response Team (PSIRT) (reachable at PSIRT@nxp.com) that manages the investigation, reporting, and solution release to security vulnerabilities of NXP products.

20.4 Trademarks

Notice: All referenced brands, product names, service names and trademarks are the property of their respective owners.

NXP — wordmark and logo are trademarks of NXP B.V.

Contents

1	General description	1	10	Current consumption	31
2	Features and benefits	2	11	Limiting values	33
3	Applications	3	12	Electrical characteristics	34
4	Ordering information	3	13	Application information	35
5	Block diagram	4	13.1	Headset application diagram	35
6	Package and pinning information	6	13.2	Dongle application diagram	36
6.1	Package	6	13.3	External decoupling capacitors	36
6.2	Pinning	6	13.4	PCB reliability	36
7	Functional description	9	14	Package outline	37
7.1	RF radio transceiver	9	15	Handling information	38
7.1.1	Features	9	16	Packaging information	38
7.1.2	Synthesizer specification	10	17	Abbreviations	39
7.1.3	Transmitter specification	10	18	References	41
7.1.4	Receiver specifications	11	19	Revision history	42
7.2	Wireless link controller	13	20	Legal information	43
7.2.1	On-chip buses	13			
7.2.1.1	Advanced peripheral bus (APB)	13			
7.2.1.2	HSI data bus	13			
7.2.2	ARM Cortex-M0 MCU subsystem	13			
7.2.3	SPI slave	14			
7.2.4	UARTs	16			
7.2.5	Dataport (I2S or TDM)	16			
7.2.6	Clock shop	17			
7.2.7	Timers	17			
7.2.8	Audio processing	17			
7.2.8.1	G.722 codec	17			
7.2.8.2	Latency control	17			
7.2.8.3	CoolFlux audio DSP	18			
7.2.9	Random number generator (RNG)	18			
7.2.10	RF HWMAC accelerator	18			
7.2.10.1	External PA control	19			
7.2.11	Versatile IO switch matrix	19			
7.2.12	Power management unit (PMU)	20			
7.2.12.1	General	20			
7.2.12.2	Power-on reset (POR)	20			
7.2.12.3	Brownout detection (BOD)	22			
7.2.12.4	Persistent registers	22			
7.2.12.5	Clock generation	22			
7.2.12.6	Crystal oscillator	22			
7.2.13	One-time programmable (OTP) memory	24			
8	Debugging and testing facilities	25			
8.1	UART	25			
9	Start-up and power modes	26			
9.1	Booting procedure	26			
9.1.1	Power supply sequence	26			
9.1.2	Boot loader	26			
9.1.3	Boot time	26			
9.2	State diagram	27			
9.2.1	Reset (undefined)	28			
9.2.2	Init	28			
9.2.3	SPI command handler	28			
9.2.4	Active user mode	29			
9.2.5	Sleep	30			

Please be aware that important notices concerning this document and the product(s) described herein, have been included in section 'Legal information'.

Mouser Electronics

Authorized Distributor

Click to View Pricing, Inventory, Delivery & Lifecycle Information:

NXP:

[NXH3670SDKUL](#) [NXH3670ADK](#)