

MAX77757 Evaluation Kit

Evaluates: MAX77757

General Description

The MAX77757 evaluation kit (EV kit) is a fully assembled and tested printed circuit board (PCB) that demonstrates the MAX77757, the standalone 3.15A USB Type-C® autonomous charger with JEITA.

The MAX77757 can operate from 4.5V to 13.7V input, with a fast-charge current up to 3.15A and a maximum input current limit of 3A. The MAX77757 is offered in several variants to support Li-ion batteries with various termination voltages from 4.1V to 4.5V. It also has a 3.6V termination voltage option for LiFePO4 batteries.

The EV kit features USB Type-C CC detection, battery charging compliant with the USB Battery Charging Specification Revision 1.2 (BC1.2), proprietary adapter detection upon input insertion, and automatic configuration of the charger input current limit to the maximum allowable current from the input source.

The MAX77757 has the reverse-boost capability, which is enabled by the ENBST pin to allow the 5.1V/1.5A output to CHGIN. The EV kit includes the variable resistor and thermistor to demonstrate the JEITA compliance.

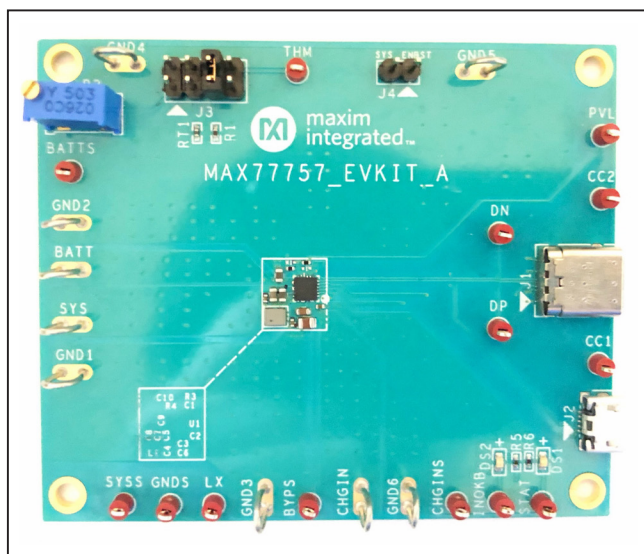

Figure 1. MAX77757 EV Kit

Benefits and Features

- Up to 16V Protection
- 13.7V Maximum Input Operating Voltage
- 3.15A Maximum Charging Current
- 6A Discharge Current Protection
- No Firmware or Communication Required
- Integrated USB Detection
 - Integrated CC Detection for USB Type-C
 - Integrated BC1.2 Detection for Legacy SDP, DCP, and CDP
 - Automatic Input Current Limit Configuration
- Input Voltage Regulation with Adaptive Input Current Limit (AICL)
- Reverse-Boost Capability up to 5.1V, 1.5A
- Termination Voltage
 - 4.1V to 4.5V for Li-ion and Li-poly Batteries
 - 3.6V/3.7V for LiFePO4 Battery
- Safety
 - Charge Safety Timer
 - JEITA Compliance with NTC Thermistor (MAX77757J)
 - HOT/COLD Stop Charging with NTC Thermistor (MAX77757H)
 - Thermal Shutdown
- Pin Control of All Functions
 - Resistor-Configurable Fast-Charge Current
 - ENBST Pin to Enable and Disable Reverse Boost
 - STAT Pin to Indicate Charging Status
 - INOKB Pin to Indicate Input Power-OK (POK)
 - THM Pin to Disable Charge
- Integrated Power Path
- Integrated Battery True-Disconnect FET
- Proven PCB Layout
- Fully Assembled and Tested

Ordering Information appears at end of data sheet.

USB Type-C and USB-C are registered trademarks of USB Implementers Forum.
Smart Power Selector is a trademark of Maxim Integrated Products, Inc.

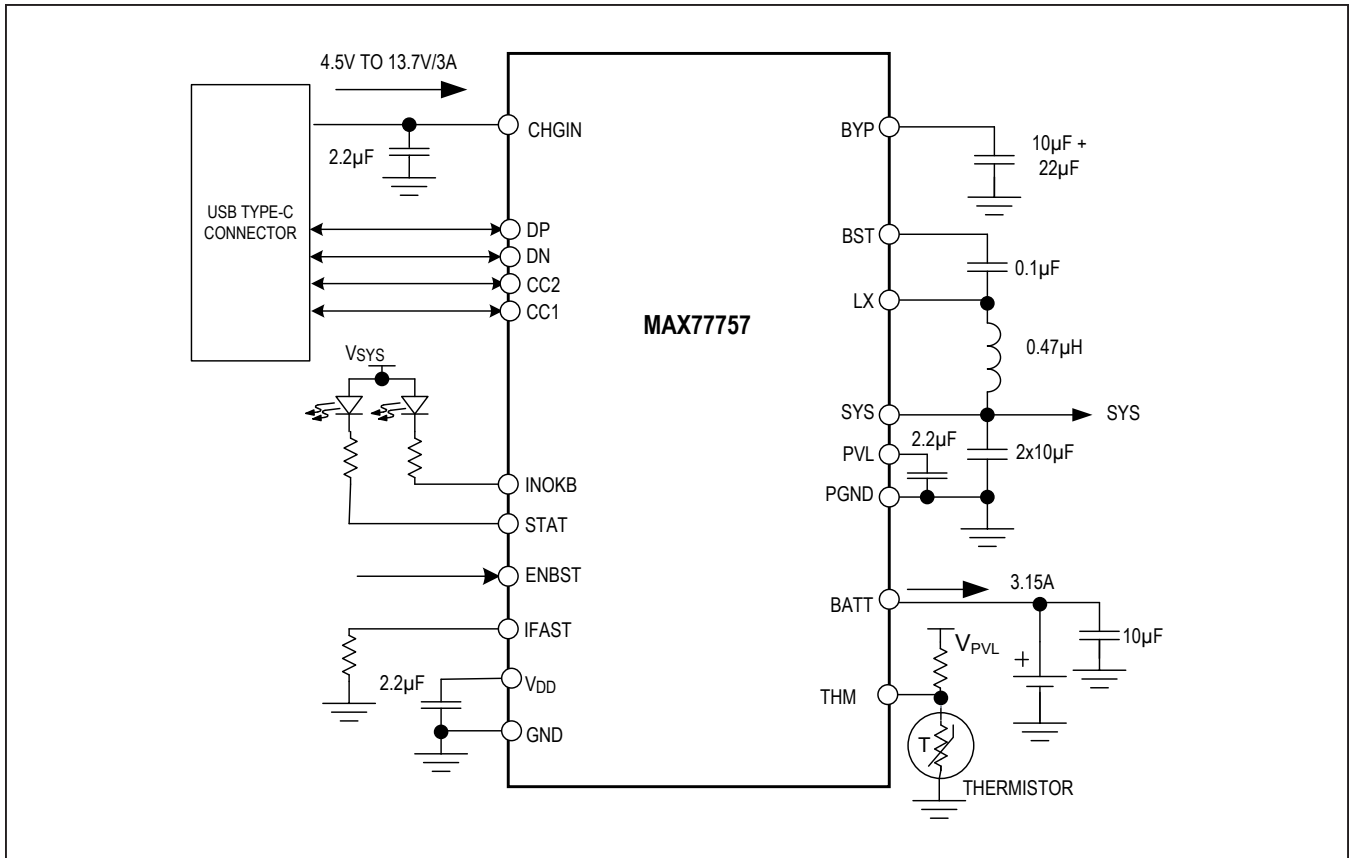

Figure 2. Simplified Block Diagram

Quick Start

Required Equipment

- MAX77757 evaluation kit
- USB Type-C travel adapter and cable
- Power supply
- Battery/battery simulator/power supply with electronic load
- Oscilloscope
- Multimeters

Initial Test Setup

The EV kit is fully assembled and tested. Follow the steps to verify board operation:

- 1) Do not turn on the DC power supply until all connections are made.
- 2) Confirm that all jumpers are at their default positions as indicated in [Table 1](#).
- 3) Connect the battery/battery simulator/power supply to the loop labeled BATT and GND.
- 4) Connect the power supply to the loop labeled CHGIN.
- 5) The EV kit is now ready for use.

Detailed Description of Hardware

Follow the initial test setup procedure.

Battery Charger Test Setup

The battery charger can be tested in three different ways; with a battery, battery simulator, or power supply with electronic load.

Battery

- 1) Connect the 1 cell battery pack and current meter between BATT and GND. Note: Only use a battery with a charge termination voltage that matches that of the MAX77757 populated on the board.
- 2) Connect the 5.0V/5.0A current-limited DC power supply between CHGIN and GND and turn it on.
- 3) Observe the current reading from the current meter. If the battery is discharged, the fast-charging current should match the setting with the external IFAST resistor (R4).

Battery Simulator

- 1) Connect the battery simulator between BATT and GND, adjust the voltage to 3.8V with 3.5A current limit, and turn it on.
- 2) Connect the 5.0V/5.0A current-limited DC power supply between CHGIN and GND and turn it on.
- 3) Observe the current reading from the battery simulator and see if the fast-charging current matches with the external IFAST resistor.

Power Supply with Electronic Load

- 1) Connect the power supply between BATT and GND and adjust the voltage to 3.8V with 3.5A current limit.
- 2) Connect the electronic load between BATT and GND and set the load current to 3.5A.

- 3) Turn on the power supply and electronic load.
- 4) Connect the 5.0V/5.0A current-limited DC power supply between CHGIN and GND and turn it on.
- 5) Observe the current reading from the current meter 1 and 2 (the fast-charging current equals $I_1 - I_2$) and see if this value matches with the external IFAST resistor.

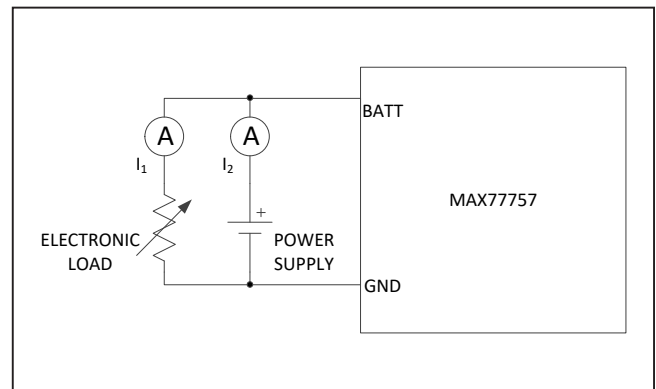

Figure 3. Battery Charger Test with Real Battery Pack

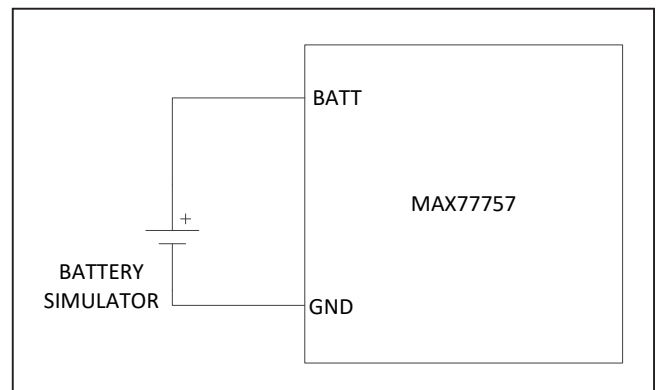

Figure 4. Battery Charger Test with Battery Simulator

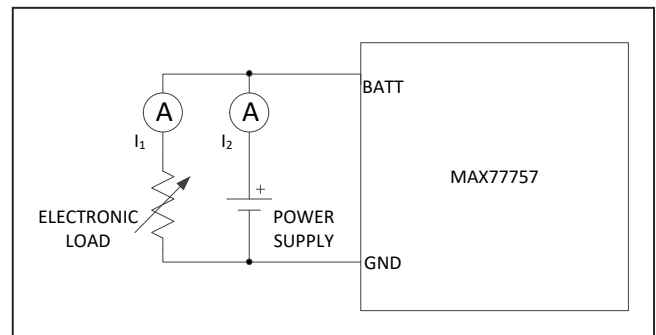

Figure 5. Battery Charger Test with Power Supply and Electronic Load

Table 1. Default Shunt Positions and Jumper Descriptions

JUMPER #	DEFAULT POSITION	FUNCTION
J3	Short 5-6	Short 1-2: Connect THM pin to a variable resistor
		Short 3-4: Connect THM pin to a thermistor
		Short 3-4 Connect THM pin to a thermistor
		Short 5-6: Connect THM pin to a fixed value resistor
		Short 7-8: Connect THM pin to GND
J4	Open	Short 1-2: Enable the Reverse Boost

BC1.2 and CC Detection Test Setup

- 1) Connect the battery/battery simulator/power supply with electronic load between BATT and GND. See the [Battery Charger Test Setup](#) section for details.
- 2) Plug in the USB Type-C cable from the PC or AC adaptor.
- 3) Check if the MAX77757 configures the input current limit correctly.

Reverse Boost Test Setup

- 1) Connect the power supply between BATT and GND, adjust the voltage to 3.8V with 3.5A current limit, and turn it on.
- 2) Apply the Jumper 4 to enable the reverse-boost mode.

- 3) Monitor the voltage of CHGIN and see whether it equals 5.1V.

LED Indicator

- 1) Two LED indicators are installed on the EV kit: DS1 (Green) is for the STAT pin and DS2 (Red) is for INOKB.
- 2) The STAT pin is an open-drain and active-low output that indicates charge status. See [Table 2](#) for details.
- 3) INOKB is an open-drain and active-low output that indicates the input status. If a valid input source is inserted and the buck converter starts switching, INOKB pulls low. When the reverse boost is enabled, INOKB pulls low to indicate the 5V output from CHGIN.

Table 2. STAT Output with Charging Status

CHARGING STATUS	STAT	LOGIC STATE	CHARGE STATUS LED
No Input	High Impedance	High	OFF
Trickle, Precharge, Fast Charge	Repeat Low and High Impedance with 1Hz, 50% duty cycle	After an external diode and a capacitor rectifier, High	Blinking with 1Hz, 50% duty cycle
Top-Off and Done	Low	Low	Solid ON
Faults	High Impedance	High	OFF

Component Suppliers

SUPPLIER	PHONE	WEBSITE
MURATA	770-436-1300	www.murata-northamerica.com
SAMTEC	800-726-8329	www.samtec.com
TAIYO-YUDEN	603-669-7587	www.t-yuden.com
TDK	847-803-6100	www.comopnent.tdk.com
VISHAY	408-970-5852	www.vishay.com
CYNTEC	510-668-5167	www.cyntec.com
PANASONIC	800-344-2112	www.panasonic.com

Note: Indicate that you are using the MAX77757 when contacting these component suppliers.

Ordering Information

PART NUMBER	IC	TYPE	THERMAL PROTECTION	TERMINATION VOLTAGE (V)
MAX77757JEVKIT435#	MAX77757JEFG435+	EV KIT	JEITA	4.35
MAX77757JEVKIT420#	MAX77757JEFG420+	EV KIT	JEITA	4.2
MAX77757HEVKIT360#	MAX77757HEFG360+	EV KIT	HOT/COLD STOP	3.6

#Denotes RoHS compliant.

MAX77757 EV Kit Bill of Materials

QTY	REF DES	MFG PART #	MANUFACTURER	VALUE
9	BATT, CHGIN, GND1-GND6, SYS	9020 BUSS	WEICO WIRE	MAXIMPAD
14	BATTS, BYPS, CC1, CC2, CHGI- NS, DN, DP, GNDS, INOKB, LX, PVL, STAT, SYSS, THM	5000	KEYSTONE	N/A
2	C1, C8	C1005X5R1A225K050BC	TDK	2.2UF
1	C2	EMK105ABJ225MV;GRM155R61C 225ME11	TAIYO YUDEN;KEMET	2.2UF
1	C3	C1608JB1C106M080AB	TDK	10UF
1	C4	GRM155R61C104KA88	MURATA	0.1UF
3	C5, C7, C9	C1608X5R1A106K080AC	TDK	10UF
1	C6	N/A	N/A	22UF
1	DS1	SML-311YTT86	ROHM	SML-311YTT86
1	DS2	SML-311UT	ROHM	SML-311UTT86
1	J1	12401832E402A	AMPHENOL	12401832E402A
1	J2	10118193-0001LF	FCI CONNECT	10118193-0001LF
1	J3	PEC04DAAN	SULLINS ELECTRONICS CORP.	PEC04DAAN
1	J4	TSW-102-07-T-S	SAMTEC	TSW-102-07-T-S
1	L1	HTEH25201T-R47MSR-63	CYNTEC	HTGH25201T-R47MSR-68
1	MISC1	AK67421-1-R	ASSMANN	AK67421-1-R
2	R1, R3	CRCW040210K0FK; RC0402FR-0710KL	VISHAY DALE; YAGEO PHICOMP	10K
1	R2	3296Y-1-503LF	BOURNS	50K
1	R4	ERJ-2RKF2492	PANASONIC	24.9K
2	R5, R6	CR0402-16W-1651FT; CRC- W04021K65FK	VENKEL LTD.;VISHAY DALE	1.65K
1	RT1	NCP15XH103F03	MURATA	10K
1	U1	MAX77757	MAXIM	MAX77757
1	PCB	MAX77757	MAXIM	PCB

MAX77757 EV Kit PCB Layout

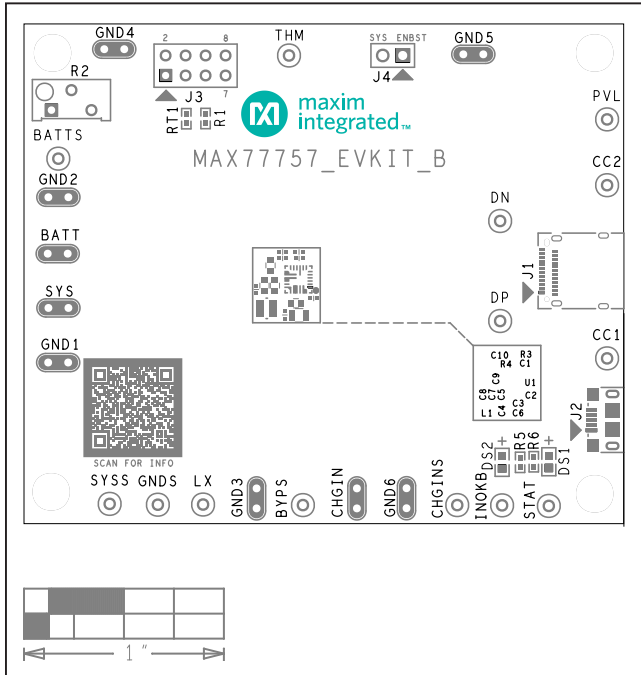

MAX77757 EV Kit Component Placement Guide—Top Silkscreen

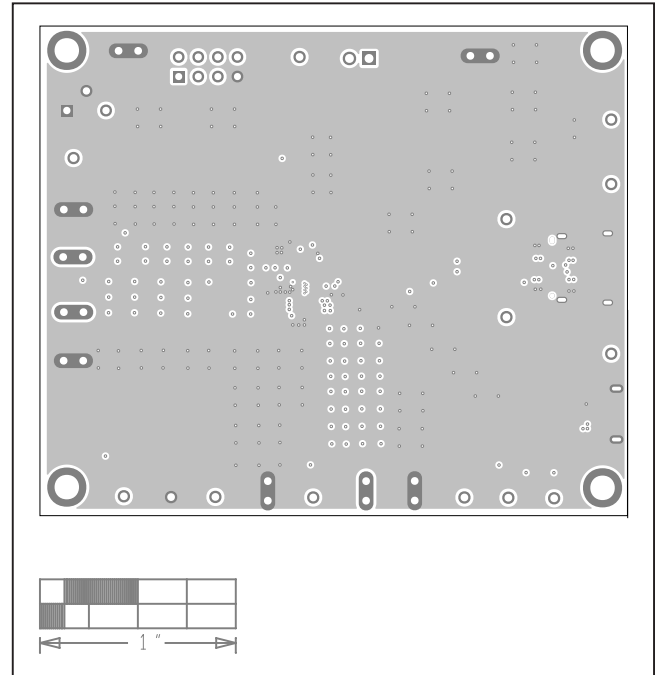

MAX77757 EV Kit PCB Layout—Internal 2

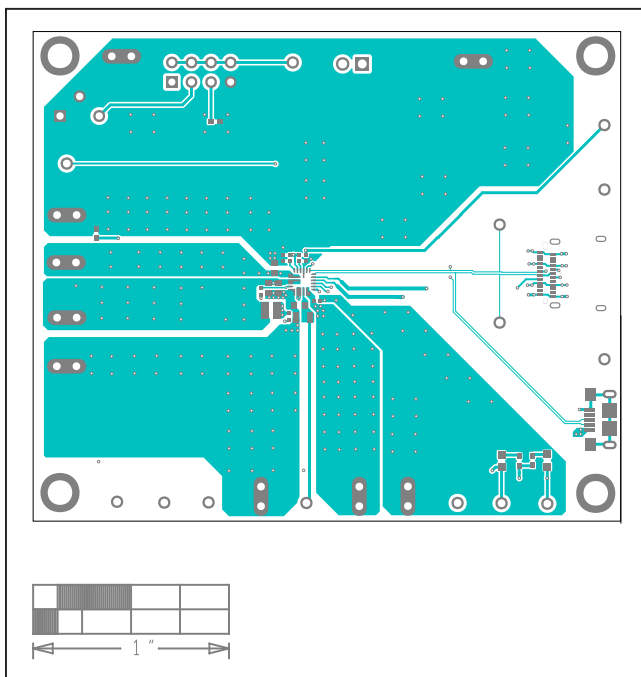

MAX77757 EV Kit PCB Layout—Top

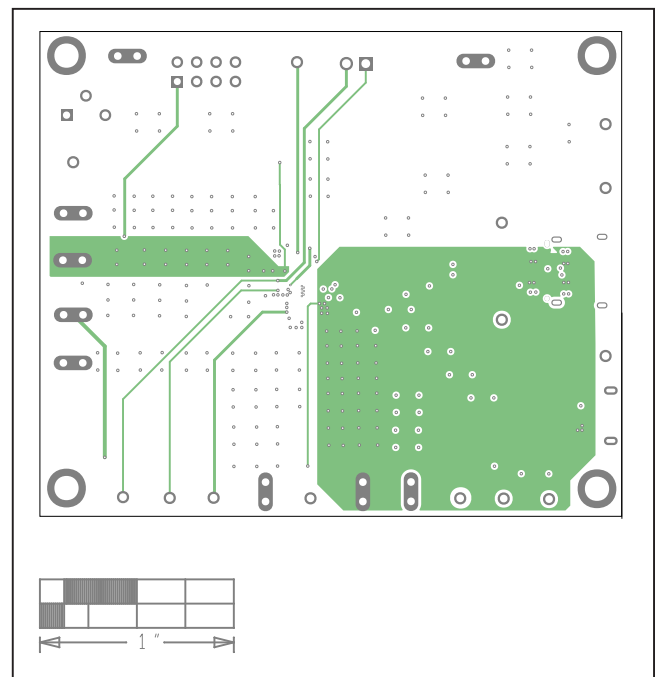

MAX77757 EV Kit PCB Layout—Internal 3

MAX77757 EV Kit PCB Layout (continued)

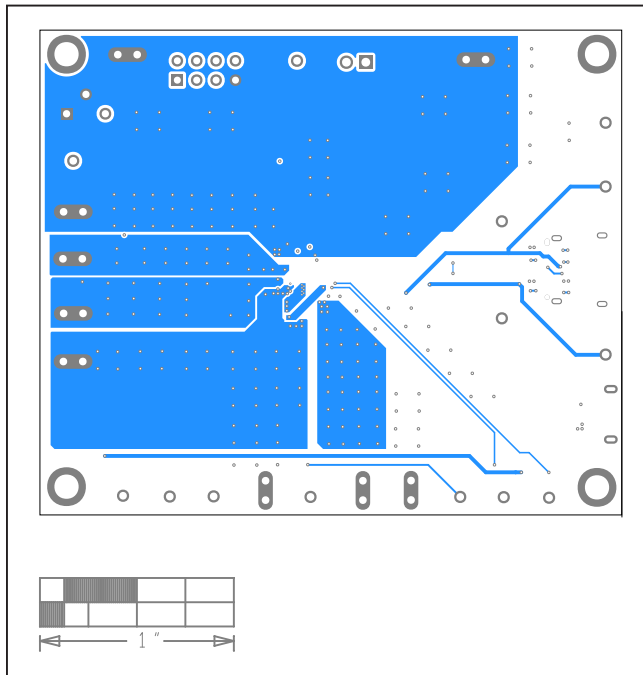

MAX77757 EV Kit PCB Layout—Bottom

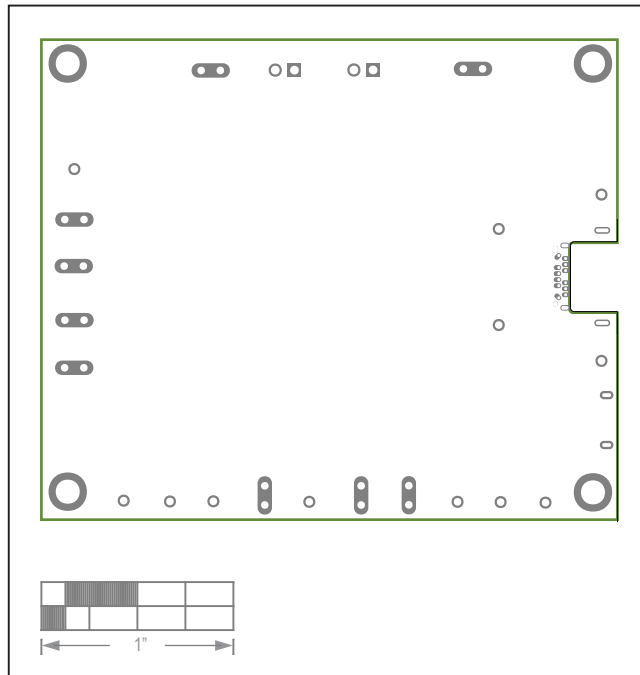

MAX77757 EV Kit Component Placement Guide—Bottom Silkscreen

Revision History

REVISION NUMBER	REVISION DATE	DESCRIPTION	PAGES CHANGED
0	3/21	Initial release	—
1	3/21	Updated <i>Ordering Information</i> table	4

For pricing, delivery, and ordering information, please visit Maxim Integrated's online storefront at <https://www.maximintegrated.com/en/storefront/storefront.html>.

Maxim Integrated cannot assume responsibility for use of any circuitry other than circuitry entirely embodied in a Maxim Integrated product. No circuit patent licenses are implied. Maxim Integrated reserves the right to change the circuitry and specifications without notice at any time.

Mouser Electronics

Authorized Distributor

Click to View Pricing, Inventory, Delivery & Lifecycle Information:

[Maxim Integrated:](#)

[MAX77757JEVKIT435#](#)