

LSP3-20 Surge Protection Device

The Hatch LSP3 surge protection device provides single phase protection for line/neutral, line/ground and neutral/ground in accordance with recommendations in IEEE C62.41.2-2002 Category C High Exposure (10KV, 1.2/50µS & 10KA, 8/20µS) and the surge limits and testing requirements specified in ANSI C82.77-5-2017 for lighting equipment, Category C High Exposure level (20KV, 1.2/50µS & 10KA, 8/20µS). The unit was designed to meet new design requirements for luminaires using LED light engines. The LSP3 offers protection for LED luminaires in a small and convenient flat form factor with thermal protection and an EOL (end-of-life) LED indicator that monitors L/N, L/G and N/G.

The surge protector is **Type 4CA SPD** and is designed to be wired in parallel. Also protects Electronic Fluorescent & HID ballasts as well as all other electronic products.

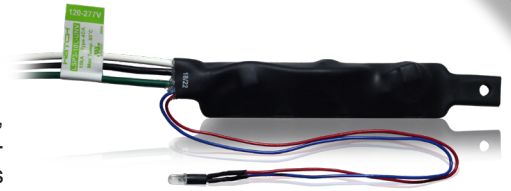

Field or Factory
Installable

SPECIFICATIONS:

Model:	LSP3-20(L)-UNV	LSP3-20(L)-480
Input Voltage:	120-277V (+/- 5%)	347-480V (+/- 5%)
Frequency:	50Hz-60Hz	50Hz-60Hz
Maximum Continuous Voltage:	385V	550V
Maximum Discharge Current:	20kA (8/20µs standard wave)	
Nominal Discharge Current:	10kA	
Max Case Temperature:	85°C	
Measured Limiting Voltage (VpK):	L-N, L-G, N-G	L-N, L-G, N-G
	1870	2480

Pulse Rating (8 x 20 µSec)	
Surge Level	# of Strikes L-N, L-G, N-G
20,000A	1
15,000A	2
10,000A	15
4,000A	100
1,400A	1000

MECHANICAL DIMENSIONS:

in [mm] † Reference Dimensions Only

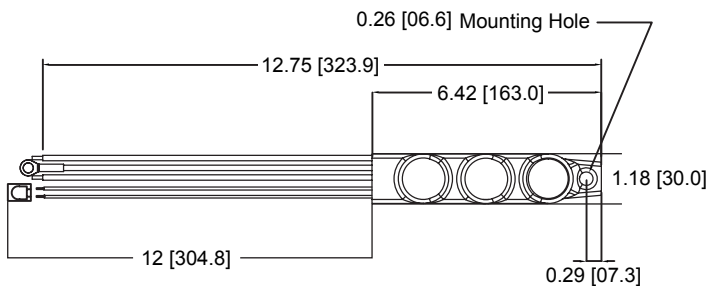

DIMENSIONS [IN/MM]

Length:	6.42 [163.0]
Mounting hole:	0.26 [6.6]
Width:	1.18 [30.0]
Height:	0.80 [20.0]

WIRING INFORMATION

Surge Protector Wires	6", Black (L), White (N), Green (G) #14 AWG
EOL Indicator wires (optional)	12", Red (R), Blue(B) #22AWG

PACKAGING INFORMATION

Weight: UNV/480	3.57/4.06oz
Weight with optional EOL: UNV/480	3.90/4.42oz
Quantity:	50pc/carton

WARRANTY

- 5 year limited warranty

WIRING DIAGRAM:

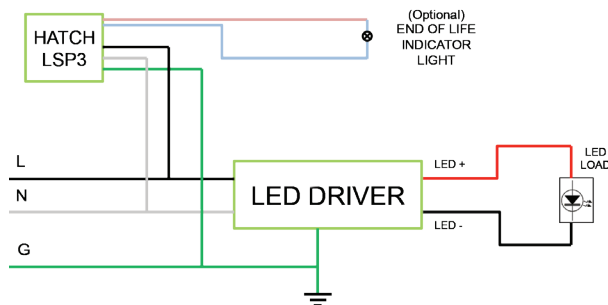

EOL Indicator: When illuminated, LSP3 is working correctly. When the indicator goes out, LSP3 needs to be replaced as soon as possible.

Note: LED Mounting Clip: BIVAR model: C-150-SR

ORDERING GUIDE

LSP3-20-UNV	No EOL
LSP3-20L-UNV	With EOL
LSP3-20-480	No EOL
LSP3-20L-480	With EOL

Specifications subject to change without notice.

Mouser Electronics

Authorized Distributor

Click to View Pricing, Inventory, Delivery & Lifecycle Information:

[Hatch Lighting:](#)

[LSP3-20L-480](#) [LSP3-20-UNV](#) [LSP3-20-480](#) [LSP3-20L-UNV](#)