

FEATURES

Improved design journey

Fully differential ADC driver with selectable input range

Input ranges with 5 V V_{REF} : ± 10 V, ± 5 V, or ± 2.5 V

Essential passive components included

$\pm 0.005\%$ *i*Passives matched resistor array

Wide input common-mode voltage range

High common-mode rejection ratio

Single-ended to differential conversion

Increased signal chain density

Small, 7 mm × 7 mm, 0.80 mm pitch, 49-ball CSP_BGA

4× footprint reduction vs. discrete solution

On-board reference buffer with V_{CM} generation

High performance

Throughput: 2 MSPS, no pipeline delay

Guaranteed 18-bit no missing codes

INL: ± 3 ppm typical, ± 8 ppm guaranteed

SINAD: 99 dB typical ($G = 0.454$)

Offset error drift: 0.7 ppm/°C typical ($G = 0.454$)

Gain error drift: ± 0.5 ppm/°C typical

Low total power dissipation: 51.6 mW typical at 2 MSPS

Serial interface SPI-/QSPI™-/MICROWIRE™-/DSP-compatible

Versatile logic interface supply with 1.8 V, 2.5 V, 3 V, or 5 V

APPLICATIONS

Automatic test equipment

Machine automation

Process controls

Medical instrumentation

Digital control loops

GENERAL DESCRIPTION

The ADAQ4003 is a μModule® precision data acquisition (DAQ), signal chain solution that reduces the development cycle of a precision measurement system by transferring the signal chain design challenge of component selection, optimization, and layout from the designer to the device.

Using system-in-package (SIP) technology, the ADAQ4003 reduces end system component count by combining multiple common signal processing and conditioning blocks into a single device. These blocks include a high resolution 18-bit, 2 MSPS successive approximation register (SAR), analog-to-digital converter (ADC), a low noise, fully differential ADC driver amplifier (FDA), and a stable reference buffer.

Using Analog Devices, Inc., *i*Passives® technology, the ADAQ4003 also incorporates crucial passive components with superior matching and drift characteristics to minimize temperature dependent error sources and to offer optimized performance (see Figure 1). Housing this signal chain solution in a small, 7 mm × 7 mm, 0.80 mm pitch, 49-ball CSP_BGA enables compact form factor designs without sacrificing performance and simplifies end system bill of materials management. This level of system integration makes the ADAQ4003 much less sensitive to printed circuit board (PCB) layout while still providing flexibility to adapt to a wide range of signal levels.

The serial peripheral interface (SPI)-compatible, serial user interface is compatible with 1.8 V, 2.5 V, 3 V, or 5 V logic, using a separate VIO supply. Specified operation of ADAQ4003 is from -40°C to $+125^{\circ}\text{C}$.

FUNCTIONAL BLOCK DIAGRAM

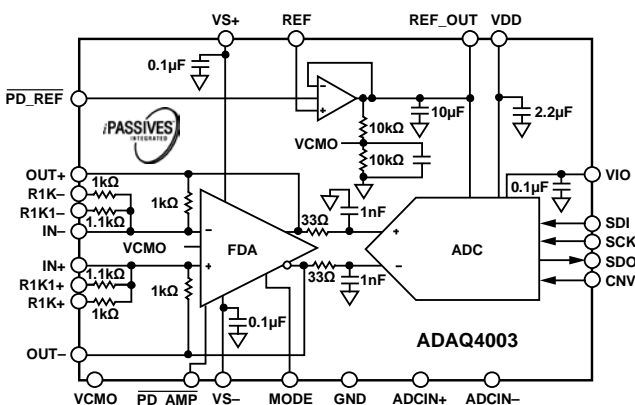

Figure 1.

Table 1. μModule Data Acquisition Solutions

| Type | 500 kSPS | ≥1000 kSPS |
|--------|--------------------------|--------------------------|
| 16-Bit | ADAQ7988 | ADAQ7980 |
| 18-Bit | | ADAQ4003 |

Rev. 0

[Document Feedback](#)

Information furnished by Analog Devices is believed to be accurate and reliable. However, no responsibility is assumed by Analog Devices for its use, nor for any infringements of patents or other rights of third parties that may result from its use. Specifications subject to change without notice. No license is granted by implication or otherwise under any patent or patent rights of Analog Devices. Trademarks and registered trademarks are the property of their respective owners.

One Technology Way, P.O. Box 9106, Norwood, MA 02062-9106, U.S.A.
Tel: 781.329.4700

©2020 Analog Devices, Inc. All rights reserved.

[Technical Support](#)

www.analog.com

TABLE OF CONTENTS

| | | | |
|---|----|---|----|
| Features | 1 | Analog Inputs | 21 |
| Applications | 1 | Ease of Drive Features | 21 |
| Functional Block Diagram | 1 | Voltage Reference Input..... | 23 |
| General Description | 1 | Power Supply (Power Tree)..... | 23 |
| Revision History | 2 | Digital Interface..... | 23 |
| Specifications | 3 | Register Read and Write Functionality..... | 24 |
| Timing Specifications | 6 | Status Word | 26 |
| Absolute Maximum Ratings | 8 | $\overline{\text{CS}}$ Mode, 3-Wire Turbo Mode..... | 27 |
| Thermal Resistance | 8 | $\overline{\text{CS}}$ Mode, 3-Wire Without Busy Indicator..... | 28 |
| Electrostatic Discharge (ESD) Ratings..... | 8 | $\overline{\text{CS}}$ Mode, 3-Wire with Busy Indicator..... | 29 |
| ESD Caution..... | 8 | $\overline{\text{CS}}$ Mode, 4-Wire Turbo Mode..... | 30 |
| Pin Configuration and Function Descriptions | 9 | $\overline{\text{CS}}$ Mode, 4-Wire Without Busy Indicator..... | 31 |
| Typical Performance Characteristics..... | 11 | $\overline{\text{CS}}$ Mode, 4-Wire with Busy Indicator..... | 32 |
| Terminology..... | 17 | Daisy-Chain Mode..... | 33 |
| Theory of Operation | 18 | Layout Guidelines | 34 |
| Circuit Information | 18 | Outline Dimensions..... | 35 |
| Transfer Functions..... | 18 | Ordering Guide | 35 |
| Applications Information..... | 19 | | |
| Typical Application Diagrams..... | 19 | | |

REVISION HISTORY

9/2020—Revision 0: Initial Version

SPECIFICATIONS

VDD = 1.8 V ± 5%, VS+ = 5.5 V ± 5%, VS- = 0 V, VIO = 1.7 V to 5.5 V, reference voltage (VREF) = 5 V, sampling frequency (fs) = 2 MSPS, all specifications TMIN to TMAX, high-Z mode disabled, span compression disabled, and turbo mode enabled, unless otherwise noted. ADC driver configured in single-ended to differential configuration and fast mode, unless otherwise noted.

Table 2.

| Parameter | Test Conditions/Comments | Min | Typ | Max | Unit |
|--|---|--|----------------------------|--|----------------------------|
| RESOLUTION | | 18 | | | Bit |
| ANALOG INPUTS | IN+, IN-, R1K1+, R1K1-, R1K+, and R1K- | | | | |
| Input Impedance (ZIN) | Single-ended to differential configuration G = 0.454, input voltage (VIN) = 22 V p-p G = 0.909, VIN = 11 V p-p G = 1, VIN = 10 V p-p G = 1.9, VIN = 5.2 V p-p | | 1.3 1.44 1.33 778 | | kΩ kΩ kΩ Ω |
| | Fully differential configuration G = 0.454 and G = 0.909, VIN = 22 V p-p and 11 V p-p G = 1, VIN = 10 V p-p G = 1.9, VIN = 5.2 V p-p | | 1.1 1 523 | | kΩ kΩ Ω |
| Differential Input Voltage Ranges ¹ | G = 0.454, VIN = 22 V p-p G = 0.909, VIN = 11 V p-p G = 1, VIN = 10 V p-p G = 1.9, VIN = 5.2 V p-p | -2.2 × VREF -1.1 × VREF -VREF -0.526 × VREF | | +2.2 × VREF +1.1 × VREF +VREF +0.526 × VREF | V V V V |
| Input Capacitance | IN+ and IN- | | 12 | | pF |
| THROUGHPUT | | | | | |
| Complete Cycle | | 500 | | | ns |
| Conversion Time | | | 290 | 320 | ns |
| Acquisition Phase ² | | 290 | | | ns |
| Throughput Rate ³ | | 0 | | 2 | MSPS |
| Transient Response ⁴ | | | 40 | | μs |
| DC ACCURACY | Single-ended to differential configuration | | | | |
| No Missing Codes | | 18 | | | Bits |
| Integral Linearity Error (INL) | All gains, VS- = -1 V | -8 -2.1 | ±3 ±0.8 | +8 +2.1 | ppm LSB ⁵ |
| Differential Linearity Error (DNL) | All gains, VS- = -1 V | -1 -3.8 | ±0.4 ±2.66 | +1 +3.8 | LSB ⁵ ppm |
| Transition Noise | All gains | | 0.93 | | LSB |
| Gain Error | All gains | -0.05 | ±0.005 | +0.05 | %FS |
| Gain Error Drift | All gains | -3 | ±0.5 | +3 | ppm/°C |
| Offset Error | G = 0.454 G = 0.909, G = 1 G = 1.9 | -1 -0.9 -1.5 | ±0.1 ±0.06 ±0.01 | +1 +0.9 +1.5 | mV mV mV |
| Offset Error Drift | G = 0.454 G = 0.909 and G = 1 G = 1.9 | -8 -10 -15 | +0.7 +1.6 +2.6 | +8 +10 +15 | ppm/°C ppm/°C ppm/°C |
| Common-Mode Rejection Ratio (CMRR) | Fully differential configuration, all gains | | 90 | | dB |
| Power Supply Rejection Ratio (PSRR) | | | | | |
| Positive | VDD = 1.71 V to 1.89 V VS+ = 5.225 V to 5.775 V, VS- = 0 V | | 72 110 | | dB dB |
| Negative | VS+ = +5.5 V, VS- = 0 V to -0.5 V | | 107 | | dB |
| 1/f Noise ⁶ | Bandwidth = 0.1 Hz to 10 Hz | | 38 | | μV p-p |
| Input Current Noise | Input frequency (fIN) = 100 kHz | | 1 | | pA/√Hz |

| Parameter | Test Conditions/Comments | Min | Typ | Max | Unit |
|---|---|------|-------|-------------------|--------|
| AC ACCURACY | Single-ended to differential and fully differential configuration | | | | |
| Dynamic Range | All gains, -60 dBFS | 94.5 | | | dB |
| | G = 0.454 | | 100 | | dB |
| | G = 0.909 and G = 1 | | 97.5 | | dB |
| | G = 1.9 | | 98.5 | | dB |
| Oversampled Dynamic Range | Oversampling ratio (OSR) = 2, all gains | | 103 | | dB |
| | OSR = 256, all gains | | 122 | | dB |
| Total RMS Noise | All gains | | 35.35 | | µV rms |
| Signal-to-Noise Ratio (SNR) | f _{IN} = 1 kHz, -0.5 dBFS | 94.2 | | | dB |
| | G = 0.454 | | 99.5 | | dB |
| | G = 0.909 and G = 1 | | 97 | | dB |
| | G = 1.9 | | 98 | | dB |
| | f _{IN} = 100 kHz, G = 0.909 | | 98 | | dB |
| | f _{IN} = 400 kHz, G = 0.909 | | 92 | | dB |
| | Low power mode enabled, G = 0.909 | | 96 | | dB |
| | VS+ = 3.3 V, VS- = 0 V, V _{REF} = 2.5 V, G = 0.909 | | 92 | | dB |
| Signal-to-Noise + Distortion (SINAD) | f _{IN} = 1 kHz, -0.5 dBFS | 94 | | | dB |
| | G = 0.454 | | 99 | | dB |
| | G = 0.909 and G = 1 | | 96.5 | | dB |
| | G = 1.9 | | 97.5 | | dB |
| | f _{IN} = 100 kHz, G = 0.909 | | 97.5 | | dB |
| | f _{IN} = 400 kHz, G = 0.909 | | 91.5 | | dB |
| | Low power mode enabled, G = 0.909 | | 95.5 | | dB |
| | VS+ = 3.3 V, VS- = 0 V, V _{REF} = 2.5 V, G = 0.909 | | 91.5 | | dB |
| Total Harmonic Distortion (THD) | f _{IN} = 1 kHz, -0.5 dBFS, all gains | | -120 | | dB |
| | f _{IN} = 100 kHz, G = 0.909 | | -100 | | dB |
| | f _{IN} = 400 kHz, G = 0.909 | | -95 | | dB |
| | Low power mode enabled, G = 0.909 | | -110 | | dB |
| | VS+ = 3.3 V, VS- = 0 V, V _{REF} = 2.5 V, G = 0.909 | | -118 | | dB |
| Spurious-Free Dynamic Range (SFDR) | f _{IN} = 1 kHz, -0.5 dBFS, all gains | | 122 | | dB |
| | f _{IN} = 100 kHz, G = 0.909 | | 101 | | dB |
| | f _{IN} = 400 kHz, G = 0.909 | | 95 | | dB |
| | Low power mode enabled, G = 0.909 | | 110 | | dB |
| | VS+ = 3.3 V, VS- = 0 V, V _{REF} = 2.5 V, G = 0.909 | | 118 | | dB |
| -3 dB Input Bandwidth | | | 4.4 | | MHz |
| Recovery Time | | | | | |
| Input Overdrive | All gains | | 280 | | ns |
| Output Overdrive | All gains | | 120 | | ns |
| Clamp | All gains | | 100 | | ns |
| Aperture Delay | | | 1 | | ns |
| Aperture Jitter | | | 1 | | ps rms |
| REFERENCE | | | | | |
| V _{REF} Range | Buffer enabled | 2.4 | | 5.1 or VS+ - 0.08 | V |
| Input Current (I _{REF}) | Buffer enabled | | 60 | | µA |
| REF_OUT Current (I _{REF_OUT}) | Buffer disabled, 2 MSPS, V _{REF} = 5 V | | 1.27 | | mA |

| Parameter | Test Conditions/Comments | Min | Typ | Max | Unit |
|--|--|---------------------|-----------------|----------------------|--------------|
| VCMO | | | | | |
| VCMO Voltage (V_{VCMO}) ⁷ | | $V_{REF}/2 - 0.003$ | $V_{REF}/2$ | $V_{REF}/2 + 0.003$ | V |
| Output Impedance | | | 5 | | k Ω |
| DIGITAL INPUTS | SDI, SCK, and CNV | | | | |
| Logic Levels | | | | | |
| Input Low Voltage (V_{IL}) | $V_{IO} > 2.7$ V | -0.3 | | $+0.3 \times V_{IO}$ | V |
| | $V_{IO} \leq 2.7$ V | -0.3 | | $+0.2 \times V_{IO}$ | V |
| Input High Voltage (V_{IH}) | $V_{IO} > 2.7$ V | $0.7 \times V_{IO}$ | | $V_{IO} + 0.3$ | V |
| | $V_{IO} \leq 2.7$ V | $0.8 \times V_{IO}$ | | $V_{IO} + 0.3$ | V |
| Input Low Current (I_{IL}) | | -1 | | +1 | μ A |
| Input High Current (I_{IH}) | | -1 | | +1 | μ A |
| Input Pin Capacitance | | | 6 | | pF |
| DIGITAL OUTPUTS ⁸ | | | | | |
| Data Format | | | Twos complement | | |
| Output Low Voltage (V_{OL}) | Sink current (I_{SINK}) = +500 μ A | | | 0.4 | V |
| Output High Voltage (V_{OH}) | Source current (I_{SOURCE}) = -500 μ A | $V_{IO} - 0.3$ | | | V |
| POWER-DOWN AND MODE SIGNALING | | | | | |
| ADC Driver and Reference Buffer | | | | | |
| PD_AMP, PD_REF, and MODE Voltage | | | | | |
| Low | Powered down, low power mode | | <1 | | V |
| High | Enabled, fast mode | | >1.7 | | V |
| POWER REQUIREMENTS | | | | | |
| VDD | | 1.71 | 1.8 | 1.89 | V |
| VS+ | | 3 | 5.5 | $VS- + 10$ | V |
| VS- | | $VS+ - 10$ | 0 | 0.1 | V |
| VIO | | 1.7 | | 5.5 | V |
| Total Standby Current ^{9, 10} | Static, all devices enabled | | 11 | 14 | mA |
| Power-Down Current | ADC driver, reference buffer disabled | | 100 | 250 | nA |
| Power Dissipation | $VDD = VIO = 1.8$ V, $VS+ = 5.5$ V, $VS- = 0$ V | | | | |
| VS+ | | | 41.5 | 51.5 | mW |
| VDD | | | 9.5 | 12 | mW |
| VIO | | | 0.6 | 0.7 | mW |
| Total | | | 51.6 | 64.2 | mW |
| | $VDD = VIO = 1.8$ V, $VS+ = 5$ V, $VS- = 0$ V, high-Z mode enabled | | | | |
| VS+ | | | 44 | 53 | mW |
| VDD | | | 12.8 | 16.5 | mW |
| VIO | | | 0.6 | 0.7 | mW |
| Total | | | 57.4 | 70.2 | mW |
| TEMPERATURE RANGE | | | | | |
| Specified Performance | T_{MIN} to T_{MAX} | -40 | | +125 | $^{\circ}$ C |

¹ V_{IN} must be within the allowed input common-mode range as per Figure 35, Figure 36, and Figure 37 and is dependent on the VS+ and VS- supply rails used.

² The acquisition phase is the time available for the input sampling capacitors to acquire a new input with the ADC running at a throughput rate of 2 MSPS.

³ A throughput rate of 2 MSPS can only be achieved with turbo mode enabled and a minimum SCK rate of 75 MHz. Refer to Table 5 for the maximum achievable throughput for different modes of operation.

⁴ Transient response is the time required for the ADAQ4003 to acquire a full-scale input step to ± 1 LSB accuracy.

⁵ The weight of the LSB, referred to input, changes depending on the input voltage range. See Table 10 for the LSB size.

⁶ See the 1/f noise plot in Figure 28.

⁷ The VCMO voltage can be used for other circuitry, but it should be driven with a buffer to ensure the VCMO voltage remains stable as per the specified range.

⁸ There is no pipeline delay. Conversion results are available immediately after a conversion is completed.

⁹ With all digital inputs forced to VIO or GND as required.

¹⁰ The total standby current during the acquisition phase.

TIMING SPECIFICATIONS

VDD = 1.8 V ± 5%, VS+ = 5.5 V ± 5%, VS- = 0 V, VIO = 1.71 V to 5.5V, VREF = 5 V, fS = 2 MSPS, all specifications TMIN to TMAX, high-Z mode disabled, span compression disabled, and turbo mode enabled, unless otherwise noted.

Table 3. Digital Interface Timing

| Parameter | Symbol | Min | Typ | Max | Unit |
|---|----------|------|-----|------|------|
| Conversion Time—CNV Rising Edge to Data Available | tCONV | | 290 | 320 | ns |
| Acquisition Phase ¹ | tACQ | 290 | | | ns |
| Time Between Conversions | tCYC | 500 | | | ns |
| CNV Pulse Width ($\overline{\text{CS}}$ Mode) ² | tCNVH | 10 | | | ns |
| SCK Period ($\overline{\text{CS}}$ Mode) ³ | tSCK | | | | |
| VIO > 2.7 V | | 9.8 | | | ns |
| VIO > 1.7 V | | 12.3 | | | ns |
| SCK Period (Daisy-Chain Mode) ⁴ | tSCK | | | | |
| VIO > 2.7 V | | 20 | | | ns |
| VIO > 1.7 V | | 25 | | | ns |
| SCK Low Time | tSCKL | 3 | | | ns |
| SCK High Time | tSCKH | 3 | | | ns |
| SCK Falling Edge to Data Remains Valid Delay | tHSDO | 1.5 | | | ns |
| SCK Falling Edge to Data Valid Delay | tDSDO | | | | |
| VIO > 2.7 V | | | | 7.5 | ns |
| VIO > 1.7 V | | | | 10.5 | ns |
| CNV or SDI Low to SDO D17 MSB Valid Delay ($\overline{\text{CS}}$ Mode) | tEN | | | | |
| VIO > 2.7 V | | | | 10 | ns |
| VIO > 1.7 V | | | | 13 | ns |
| CNV Rising Edge to First SCK Rising Edge Delay | tQUIET1 | 190 | | | ns |
| Last SCK Falling Edge to CNV Rising Edge Delay | tQUIET2 | 60 | | | ns |
| CNV or SDI High or Last SCK Falling Edge to SDO High Impedance ($\overline{\text{CS}}$ Mode) | tDIS | | | 20 | ns |
| SDI Valid Setup Time from CNV Rising Edge | tSSDICNV | 2 | | | ns |
| SDI Valid Hold Time from CNV Rising Edge ($\overline{\text{CS}}$ Mode) | tHSDICNV | 2 | | | ns |
| SCK Valid Hold Time from CNV Rising Edge (Daisy-Chain Mode) | tHSCKCNV | 12 | | | ns |
| SDI Valid Setup Time from SCK Rising Edge (Daisy-Chain Mode) | tSSDISCK | 2 | | | ns |
| SDI Valid Hold Time from SCK Rising Edge (Daisy-Chain Mode) | tHSDISCK | 2 | | | ns |

¹ The acquisition phase is the time available for the input sampling capacitors to acquire a new input with the ADC running at a throughput rate of 2 MSPS.

² For turbo mode, tCNVH must match the tQUIET1 minimum.

³ A throughput rate of 2 MSPS can only be achieved with turbo mode enabled and a minimum SCK rate of 75 MHz.

⁴ A 50% duty cycle is assumed for SCK.

Table 4. Register Read and Write Timing

| Parameter | Symbol | Min | Typ | Max | Unit |
|--|---------------|------|-----|------|------|
| READ AND WRITE OPERATION | | | | | |
| CNV Pulse Width ¹ | t_{CNVH} | 10 | | | ns |
| SCK Period | t_{SCK} | 9.8 | | | ns |
| VIO > 2.7 V | | 12.3 | | | ns |
| VIO > 1.7 V | | | | | ns |
| SCK Low Time | t_{SCKL} | 3 | | | ns |
| SCK High Time | t_{SCKH} | 3 | | | ns |
| READ OPERATION | | | | | |
| CNV Low to SDO D17 MSB Valid Delay | t_{EN} | | | 10 | ns |
| VIO > 2.7 V | | | | 13 | ns |
| VIO > 1.7 V | | | | | ns |
| SCK Falling Edge to Data Remains Valid | t_{HSDO} | 1.5 | | | ns |
| SCK Falling Edge to Data Valid Delay | t_{DSDO} | | | 7.5 | ns |
| VIO > 2.7 V | | | | 10.5 | ns |
| VIO > 1.7 V | | | | | ns |
| CNV Rising Edge to SDO High Impedance | t_{DIS} | | | 20 | ns |
| WRITE OPERATION | | | | | |
| SDI Valid Setup Time from SCK Rising Edge | $t_{SSDISCK}$ | 2 | | | ns |
| SDI Valid Hold Time from SCK Rising Edge | $t_{HSDISCK}$ | 2 | | | ns |
| CNV Rising Edge to SCK Edge Hold Time | $t_{HCNVSCK}$ | 0 | | | ns |
| CNV Falling Edge to SCK Active Edge Setup Time | $t_{SCNVSCK}$ | 6 | | | ns |

¹ For turbo mode, t_{CNVH} must match the t_{QUIET1} minimum.

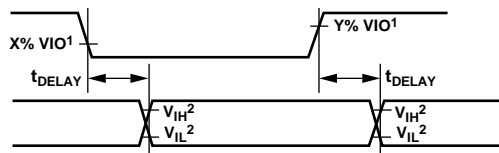

¹FOR VIO ≤ 2.7V, X = 80, AND Y = 20; FOR VIO > 2.7V, X = 70, AND Y = 30.
²MINIMUM V_{IH} AND MAXIMUM V_{IL} USED. SEE DIGITAL INPUTS SPECIFICATIONS IN TABLE 2.

21657-002

Figure 2. Voltage Levels for Timing

Table 5. Achievable Throughput for Different Modes of Operation

| Parameter | Test Conditions/Comments | Min | Typ | Max | Unit |
|--|---|-----|-----|------|------|
| THROUGHPUT, CS MODE | | | | | |
| 3-Wire and 4-Wire Turbo Mode | $f_{SCK} = 100 \text{ MHz}, VIO \geq 2.7 \text{ V}$ | | | 2 | MSPS |
| | $f_{SCK} = 80 \text{ MHz}, VIO < 2.7 \text{ V}$ | | | 2 | MSPS |
| 3-Wire and 4-Wire Turbo Mode and Six Status Bits | $f_{SCK} = 100 \text{ MHz}, VIO \geq 2.7 \text{ V}$ | | | 2 | MSPS |
| | $f_{SCK} = 80 \text{ MHz}, VIO < 2.7 \text{ V}$ | | | 1.78 | MSPS |
| 3-Wire and 4-Wire Mode | $f_{SCK} = 100 \text{ MHz}, VIO \geq 2.7 \text{ V}$ | | | 1.75 | MSPS |
| | $f_{SCK} = 80 \text{ MHz}, VIO < 2.7 \text{ V}$ | | | 1.62 | MSPS |
| 3-Wire and 4-Wire Mode and Six Status Bits | $f_{SCK} = 100 \text{ MHz}, VIO \geq 2.7 \text{ V}$ | | | 1.59 | MSPS |
| | $f_{SCK} = 80 \text{ MHz}, VIO < 2.7 \text{ V}$ | | | 1.44 | MSPS |

ABSOLUTE MAXIMUM RATINGS

Table 6.

| Parameter | Rating |
|---|---|
| Analog Inputs R1K+, R1K-, R1K1+, R1K1- to GND ¹ | -16 V to +16 V ² or ±18 mA ² |
| Supply Voltage | |
| REF_OUT and VIO to GND | -0.3 V to +6.0 V |
| VDD to GND | -0.3 V to +2.1 V |
| VDD to VIO | -6 V to +2.4 V |
| VS+ to VS- | 11 V |
| VS+ to GND | -0.3 V to +11 V |
| VS- to GND | -11 V to +0.3 V |
| Digital Inputs to GND | -0.3 V to VIO + 0.3 V |
| Digital Outputs to GND | -0.3 V to VIO + 0.3 V |
| Temperature | |
| Storage Range | -65°C to +150°C |
| Junction | 150°C |
| Lead Soldering | 260°C reflow as per JEDEC J-STD-020 |

¹ See the Analog Inputs section.

² The *i*Passives resistors can sustain specified maximum voltage and current indefinitely.

Stresses at or above those listed under Absolute Maximum Ratings may cause permanent damage to the product. This is a stress rating only; functional operation of the product at these or any other conditions above those indicated in the operational section of this specification is not implied. Operation beyond the maximum operating conditions for extended periods may affect product reliability.

THERMAL RESISTANCE

Thermal performance is directly linked to PCB design and operating environment. Careful attention to PCB thermal design is required.

θ_{JA} is the natural convection, junction to ambient thermal resistance measured in a one cubic foot sealed enclosure, and θ_{JC} is the junction to case thermal resistance.

Table 7. Thermal Resistance

| Package Type ¹ | θ_{JA} | θ_{JC} | Unit | JEDEC Board Layers |
|---------------------------|---------------|---------------|------|--------------------|
| BC-49-5 | 53.5 | 54.9 | °C/W | 2S2P |

¹ Test Condition 1: thermal impedance simulated values are based upon use of a 2S2P JEDEC standard PCB configuration per JEDEC Standard JESD51-7.

ELECTROSTATIC DISCHARGE (ESD) RATINGS

The following ESD information is provided for handling of ESD-sensitive devices in an ESD protected area only.

Human body model (HBM) per ANSI/ESDA/JEDDEC JS-001.

Field induced charged device model (FICDM) per ANSI/ESDA/JEDEC JS-002.

ESD Ratings for the ADAQ4003

Table 8. ADAQ4003, 49-Ball CSP_BGA

| ESD Model | Withstand Threshold (V) | Class |
|-----------|-------------------------|-------|
| HBM | 4000 | 2 |
| FICDM | 1000 | C4 |

ESD CAUTION



ESD (electrostatic discharge) sensitive device. Charged devices and circuit boards can discharge without detection. Although this product features patented or proprietary protection circuitry, damage may occur on devices subjected to high energy ESD. Therefore, proper ESD precautions should be taken to avoid performance degradation or loss of functionality.

PIN CONFIGURATION AND FUNCTION DESCRIPTIONS

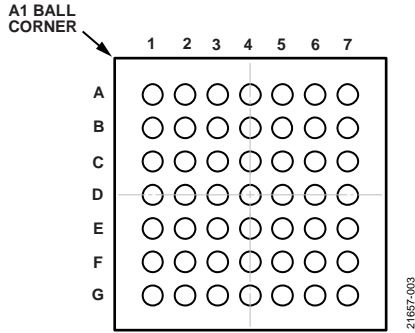

Figure 3. Ball Configuration, Top View

| | 1 | 2 | 3 | 4 | 5 | 6 | 7 |
|---|-------|-------|------|-----|---------|-----------------------------|-----|
| A | GND | VDD | OUT+ | VS- | REF_OUT | REF | GND |
| B | R1K- | R1K- | OUT+ | VS- | GND | VIO | VIO |
| C | R1K1- | R1K1- | VS- | VS- | DNC | $\overline{\text{PD_AMP}}$ | SDI |
| D | IN- | IN+ | DNC | DNC | DNC | $\overline{\text{PD_REF}}$ | SCK |
| E | R1K1+ | R1K1+ | MODE | VS+ | ADCIN+ | GND | SDO |
| F | R1K+ | R1K+ | OUT- | VS+ | DNC | DNC | CNV |
| G | GND | VCMO | OUT- | VS+ | VS+ | ADCIN- | GND |

Figure 4. Ball Configuration

Table 9. Ball Function Descriptions

| Ball No. | Mnemonic | Type ¹ | Description |
|------------------------|-----------------------------|-------------------|---|
| A1, A7, B5, E6, G1, G7 | GND | P | Power Supply Ground. |
| A2 | VDD | P | 1.8 V Power Supply. The VDD range is 1.71 V to 1.89 V. |
| A3, B3 | OUT+ | AO | Positive Output of the Fully Differential ADC Driver. |
| A4, B4, C3, C4 | VS- | P | Negative Supply of the Fully Differential ADC Driver. |
| A5 | REF_OUT | AO | Reference Buffer Output Voltage. |
| A6 | REF | AI | Reference Buffer Input Voltage. |
| B1, B2 | R1K- | AI | 1 kΩ Resistor Input to Negative Input of the Fully Differential ADC Driver. |
| B6, B7 | VIO | P | Input and Output Interface Digital Power. Nominally, the VIO pins are at the same supply as the host interface (1.8 V, 2.5 V, 3 V, or 5 V). |
| C1, C2 | R1K1- | AI | 1.1 kΩ Resistor Input to Negative Input of the Fully Differential ADC Driver. |
| C5, D3 to D5, F5, F6 | DNC | N/A | Do Not Connect. Do not connect to this pin. |
| C6 | $\overline{\text{PD_AMP}}$ | DI | Power-Down Amplifier. Active low. Connect the $\overline{\text{PD_AMP}}$ pin to GND to power down the fully differential ADC driver. Otherwise, connect the $\overline{\text{PD_AMP}}$ pin to logic high. |
| C7 | SDI | DI | Serial Data Input. This input provides multiple features. SDI selects the interface mode of the ADC as follows: Daisy-chain mode is selected if SDI is low during the CNV rising edge. In this mode, SDI is used as a data input to daisy-chain the conversion results of two or more ADCs onto a single SDO line. The digital data level on SDI is output on SDO with a delay of 18 SCK cycles. $\overline{\text{CS}}$ mode is selected if SDI is high during the CNV rising edge. In this mode, either SDI or CNV can enable the serial output signals when low. If SDI or CNV is low when the conversion is complete, the busy indicator feature is enabled. With CNV low, the device can be programmed by clocking in a 16-bit word on SDI on the rising edge of SCK. |

| Ball No. | Mnemonic | Type ¹ | Description |
|----------------|----------|-------------------|---|
| D1 | IN- | AI | Negative Input of the Fully Differential ADC Driver. |
| D2 | IN+ | AI | Positive Input of the Fully Differential ADC Driver. |
| D6 | PD_REF | DI | Power-Down Reference Buffer. Active low. Connect the PD_REF pin to GND to power down the reference buffer. Otherwise, connect the PD_REF pin to logic high. |
| D7 | SCK | DI | Serial Data Clock Input. When the device is selected, the conversion result is shifted out by this clock. |
| E1, E2 | R1K1+ | AI | 1.1 kΩ Resistor Input to Positive Input of the Fully Differential ADC Driver. |
| E3 | MODE | DI | Power Mode for the Fully Differential ADC Driver. Full performance when the MODE pin is high, and low power mode when the MODE pin is low. |
| E4, F4, G4, G5 | VS+ | P | Fully Differential ADC Driver and Reference Buffer Positive Supply. |
| E5 | ADCIN+ | AO | Positive Input to the ADC. Extra capacitance can be added on the ADCIN+ pin to reduce the RC filter bandwidth. |
| E7 | SDO | DO | Serial Data Output. The conversion result is output on the SDO pin. SDO synchronizes to SCK. |
| F1, F2 | R1K+ | AI | 1 kΩ Resistor Input to Positive Input of the Fully Differential ADC Driver. |
| F3, G3 | OUT- | AO | Negative Output of the Fully Differential ADC Driver. |
| F7 | CNV | DI | Convert Input. This input has multiple functions. On its leading edge, CNV initiates the conversions and selects the interface mode of the device: daisy-chain mode or CS mode. In CS mode, the SDO pin is enabled when CNV is low. In daisy-chain mode, the data is read when CNV is high. |
| G2 | VCMO | AO | Fully Differential ADC Driver Output Common-Mode Voltage. Nominally, $V_{REF}/2$. |
| G6 | ADCIN- | AO | Negative Input to the ADC. Extra capacitance can be added on the ADCIN- pin to reduce the RC filter bandwidth. |

¹ P is power, AO is analog output, AI is analog input, N/A is not applicable, DI is digital input, and DO is digital output.

TYPICAL PERFORMANCE CHARACTERISTICS

$V_{S+} = 5.5\text{ V}$, $V_{S-} = 0\text{ V}$, $V_{DD} = 1.8\text{ V}$, $V_{IO} = 3.3\text{ V}$, $V_{REF} = 5\text{ V}$, $T_A = 25^\circ\text{C}$, high-Z mode disabled, span compression disabled, turbo mode enabled, and $f_s = 2\text{ MSPS}$, unless otherwise noted.

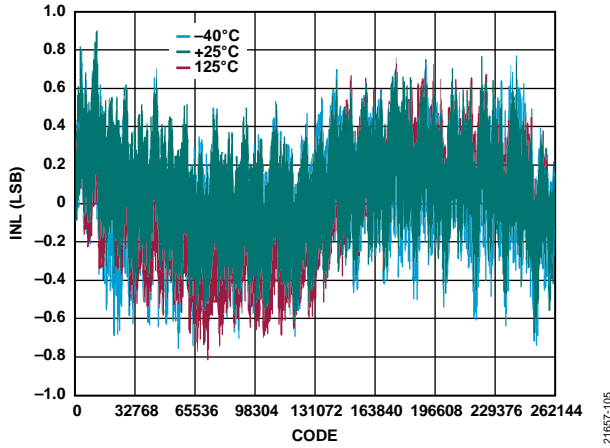

Figure 5. INL vs. Code for Various Temperatures, $V_{REF} = 5\text{ V}$, $G = 0.454$

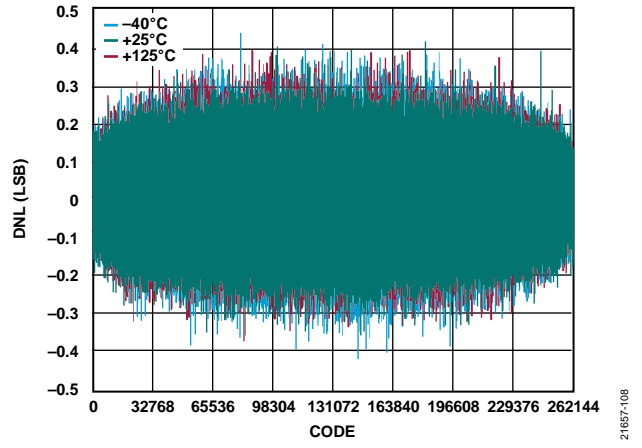

Figure 8. DNL vs. Code for Various Temperatures, $V_{REF} = 5\text{ V}$, $G = 0.454$

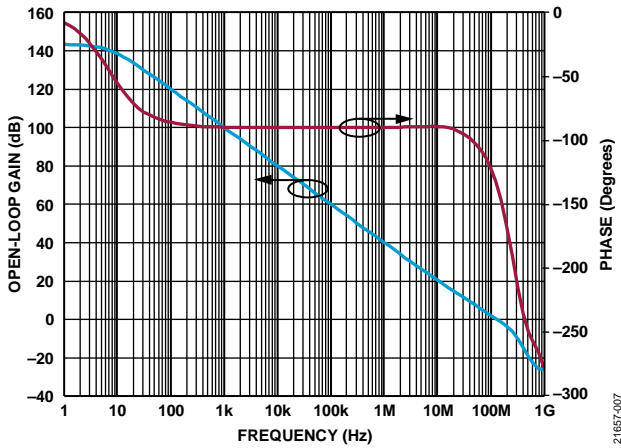

Figure 6. ADC Driver Open-Loop Gain and Phase vs. Frequency

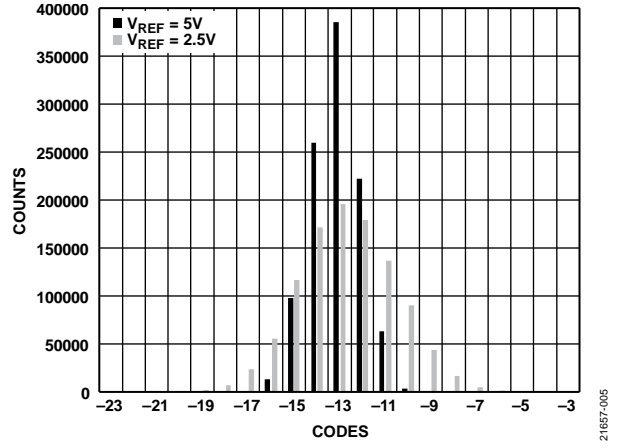

Figure 9. Histogram of a DC Input at the Code Center, $V_{REF} = 2.5\text{ V}$ and $V_{REF} = 5\text{ V}$

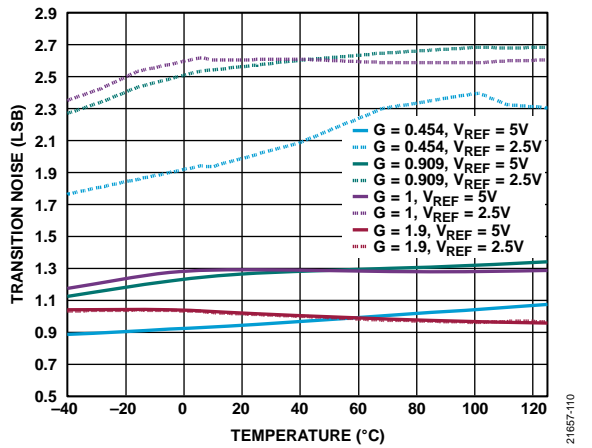

Figure 7. Transition Noise vs. Temperature for $G = 0.454$, $G = 0.909$, $G = 1$, and $G = 1.9$ and $V_{REF} = 5\text{ V}$ and $V_{REF} = 2.5\text{ V}$

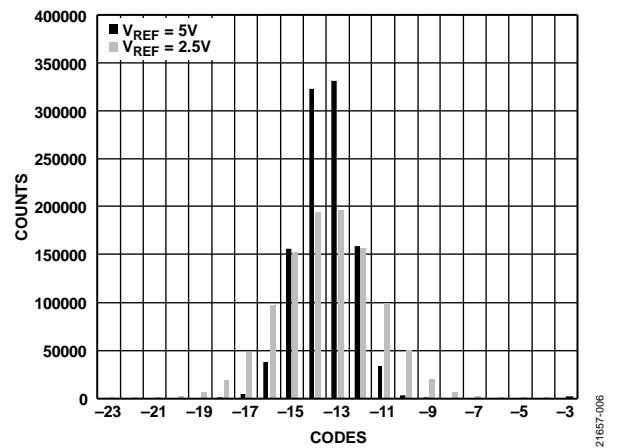

Figure 10. Histogram of a DC Input at the Code Transition, $V_{REF} = 2.5\text{ V}$ and $V_{REF} = 5\text{ V}$

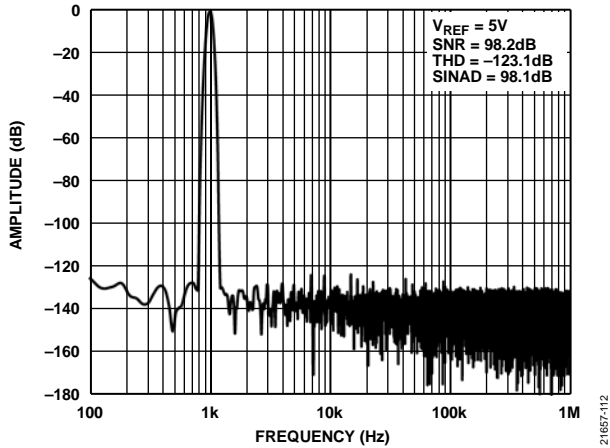

Figure 11. 1 kHz, -0.5 dBFS Input Tone Fast Fourier Transform (FFT), Wide View, $G = 1$, $V_{REF} = 5$ V, Differential

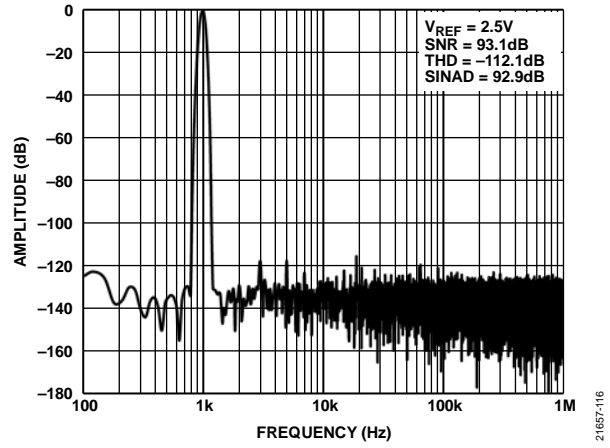

Figure 14. 1 kHz, -0.5 dBFS Input Tone FFT, Wide View, $G = 1$, $V_{REF} = 2.5$ V, Single-Ended

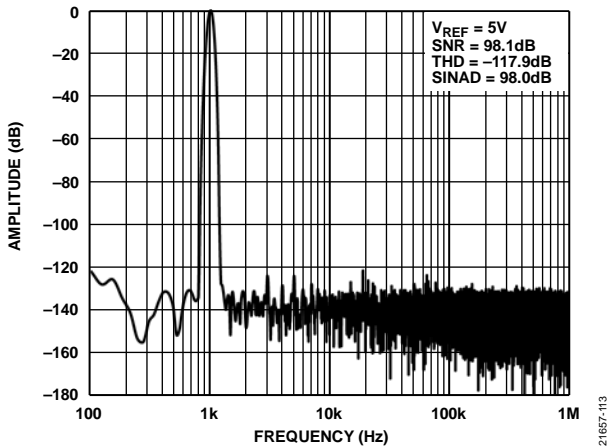

Figure 12. 1 kHz, -0.5 dBFS Input Tone FFT, Wide View, $G = 1$, $V_{REF} = 5$ V, Single-Ended

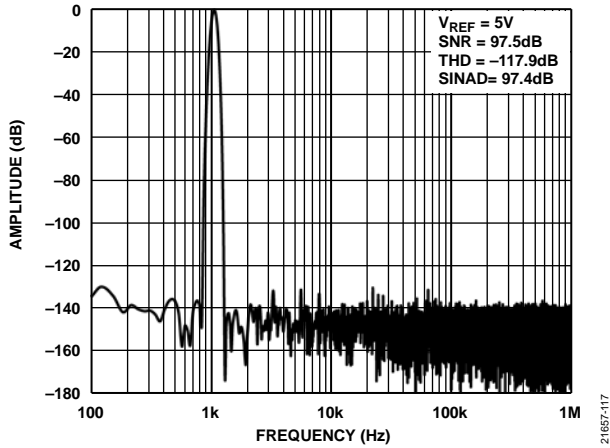

Figure 15. 1 kHz, -0.5 dBFS Input Tone FFT, Wide View, Differential, $G = 0.909$, $V_{REF} = 5$ V, Low Power Mode

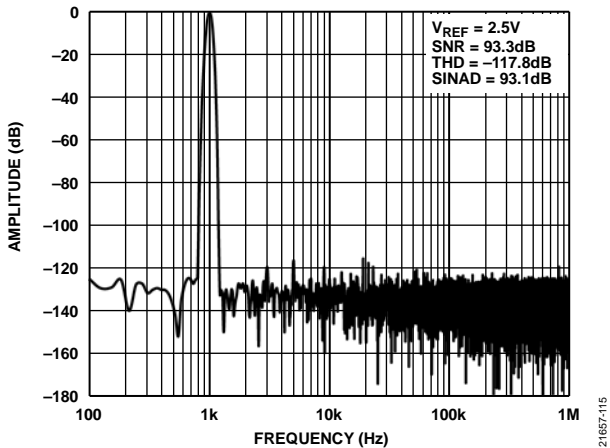

Figure 13. 1 kHz, -0.5 dBFS Input Tone FFT, Wide View, $G = 1$, $V_{REF} = 2.5$ V, Differential

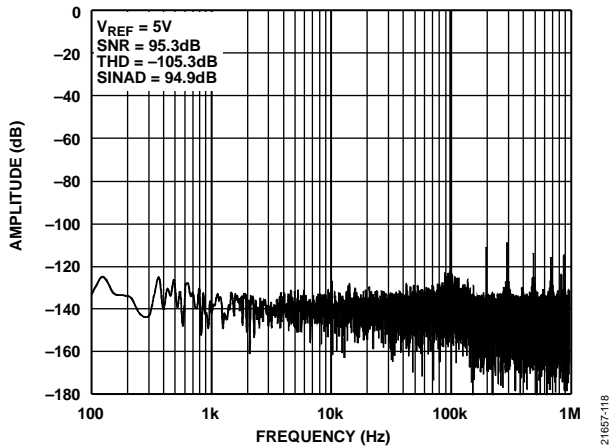

Figure 16. 100 kHz, -0.5 dBFS Input Tone FFT, Wide View, $G = 1$, $V_{REF} = 5$ V

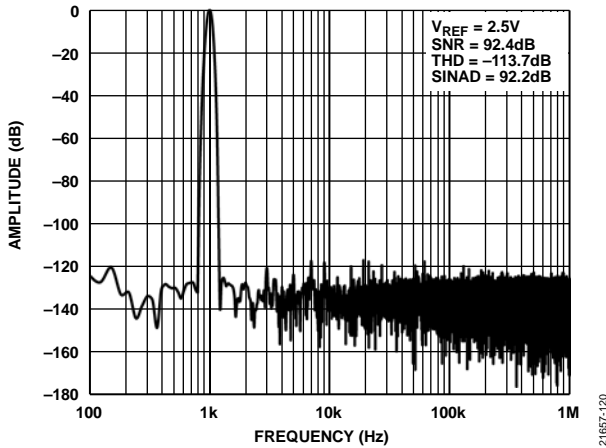

Figure 17. 1 kHz, -0.5 dBFS Input Tone FFT, Wide View, Differential, $G = 0.909$, $V_{REF} = 2.5$ V, Low Power Mode

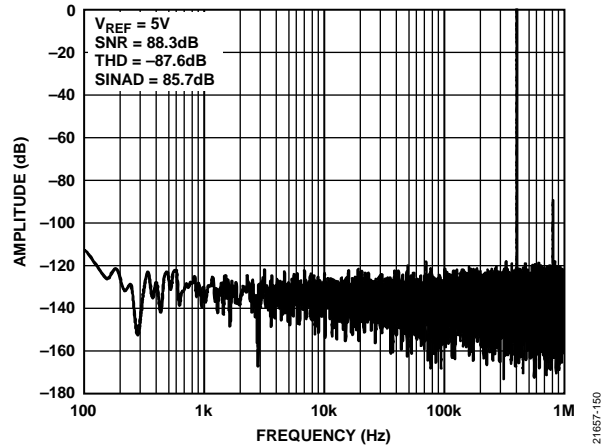

Figure 20. 400 kHz, -0.5 dBFS Input Tone FFT, $G = 1$, Wide View, $V_{REF} = 5$ V

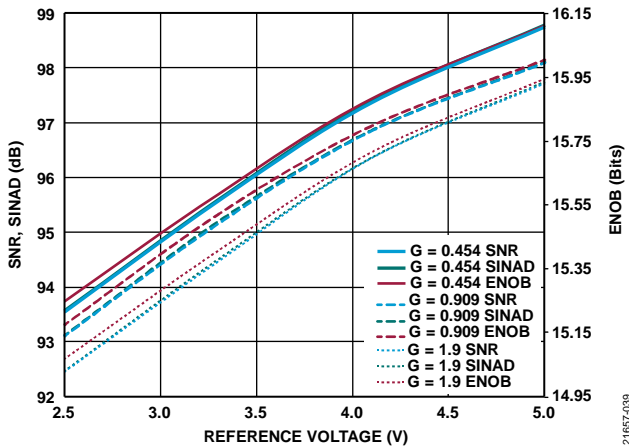

Figure 18. SNR, SINAD, and Effective Number of Bits (ENOB) vs. Reference Voltage for $G = 0.454$, $G = 0.909$, and $G = 1.9$, $f_{IN} = 1$ kHz

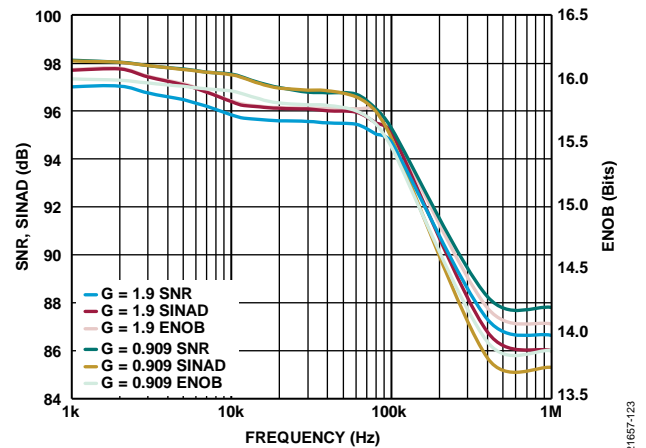

Figure 21. SNR, SINAD, and ENOB vs. Frequency for $G = 1.9$ and $G = 0.909$, $V_{REF} = 5$ V

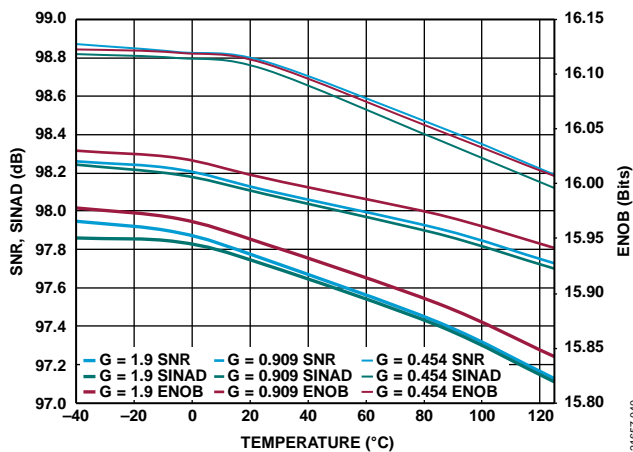

Figure 19. SNR, SINAD, and ENOB vs. Temperature, $G = 1.9$, $G = 0.909$, and $G = 0.454$, $f_{IN} = 1$ kHz

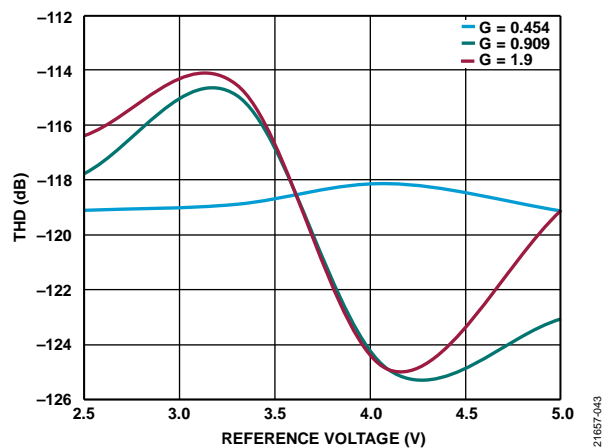

Figure 22. THD vs. Reference Voltage, $G = 0.454$, $G = 0.909$, and $G = 1.9$, $f_{IN} = 1$ kHz

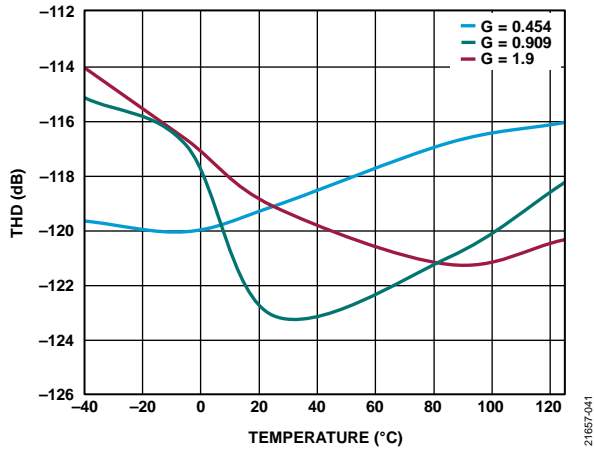

Figure 23. THD vs. Temperature for $G = 0.454$, $G = 0.909$, and $G = 1.9$, $f_{IN} = 1\text{ kHz}$

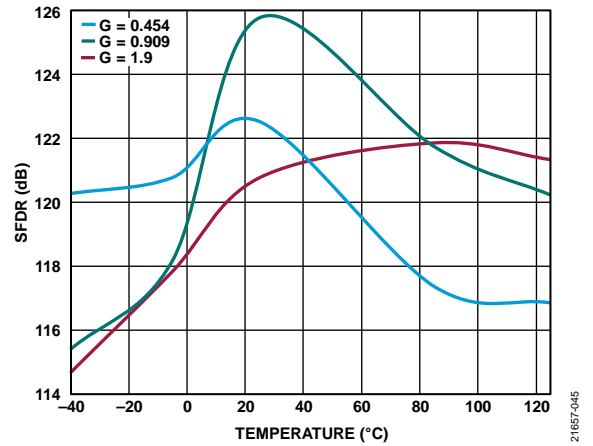

Figure 26. SFDR vs. Temperature for $G = 0.454$, $G = 0.909$, and $G = 1.9$, $f_{IN} = 1\text{ kHz}$

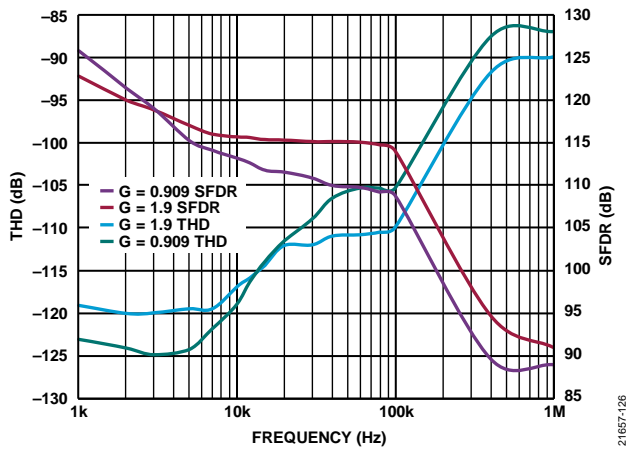

Figure 24. THD and SFDR vs. Frequency for $G = 0.909$ and $G = 1.9$, $V_{REF} = 5\text{ V}$

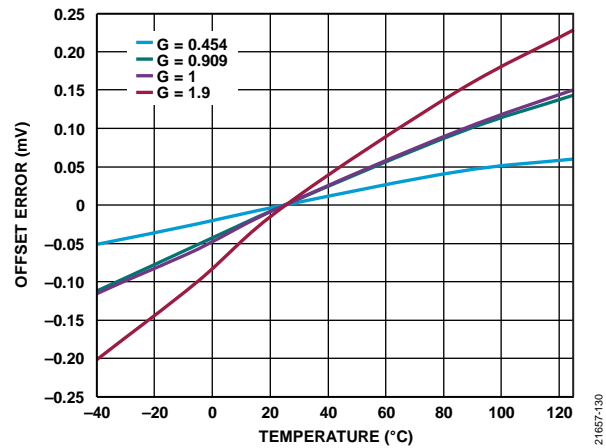

Figure 27. Offset Error vs. Temperature for $G = 0.454$, $G = 0.909$, $G = 1$, and $G = 1.9$

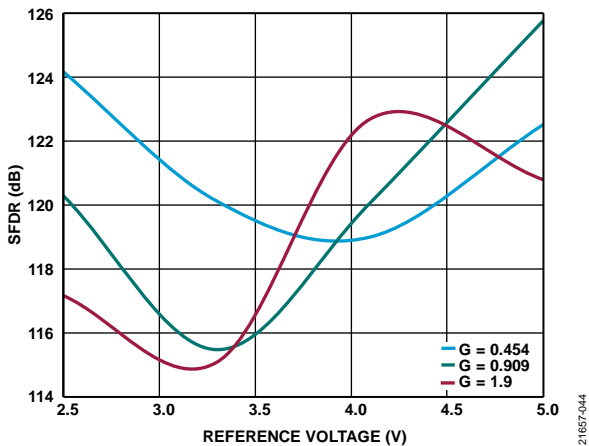

Figure 25. SFDR vs. Reference Voltage for $G = 0.454$, $G = 0.909$, and $G = 1.9$, $f_{IN} = 1\text{ kHz}$

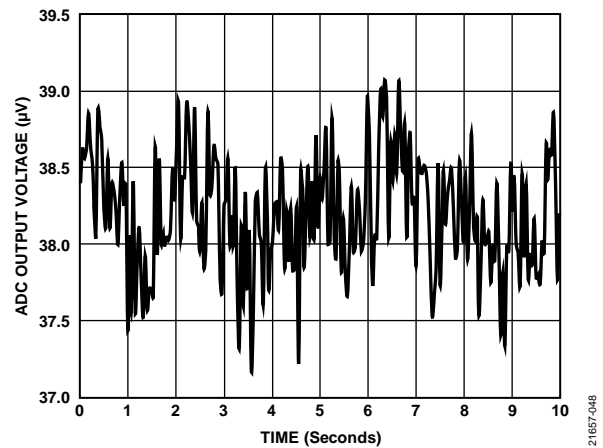

Figure 28. $1/f$ Noise for 0.1 Hz to 10 Hz Bandwidth, 100 kSPS, 250 Samples Averaged per Reading

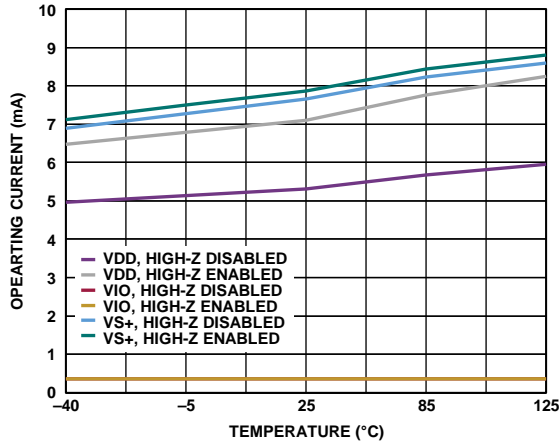

Figure 29. Operating Current vs. Temperature, 2 MSPS

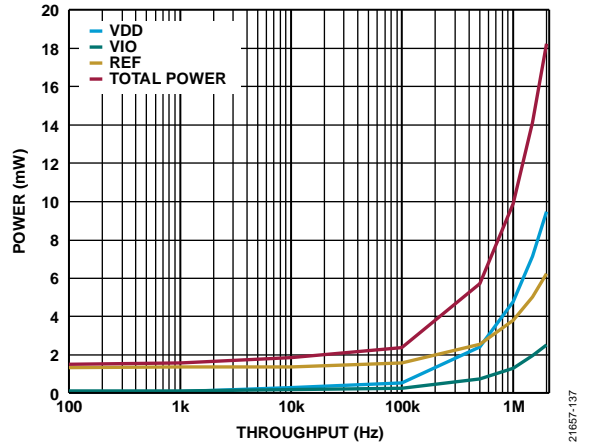

Figure 32. Power vs. Throughput

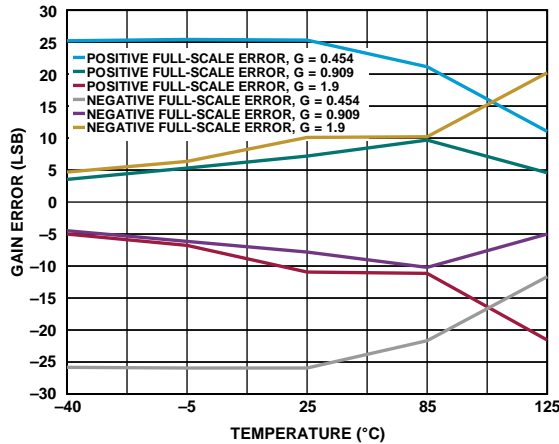

Figure 30. Gain Error vs. Temperature for Positive Full-Scale Error and Negative Full-Scale Error and for $G = 0.454$, $G = 0.909$, and $G = 1.9$

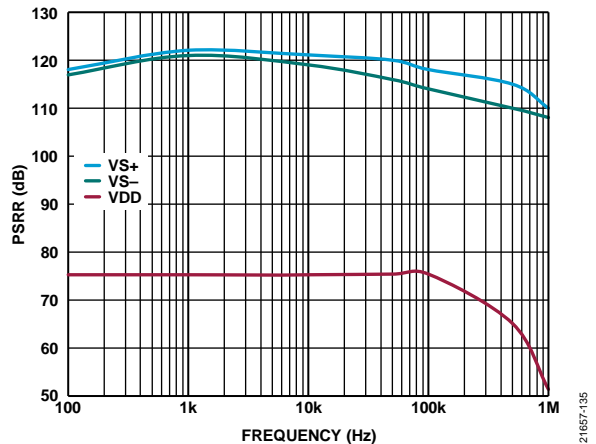

Figure 33. PSRR vs. Frequency

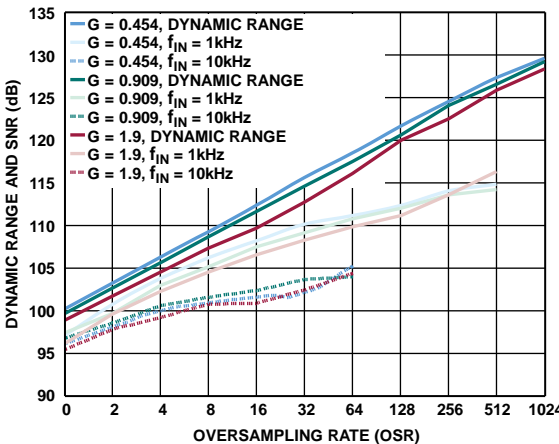

Figure 31. Dynamic Range and SNR vs. Oversampling Rate for $G = 0.454$, $G = 0.909$, and $G = 1.9$, and for Input Frequencies, 2 MSPS

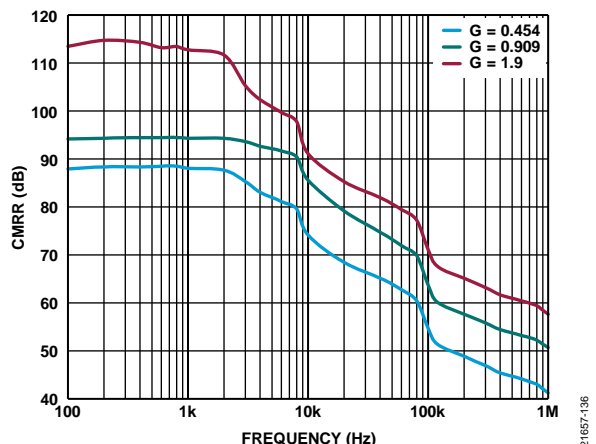

Figure 34. CMRR vs. Frequency for $G = 0.454$, $G = 0.909$, and $G = 1.9$

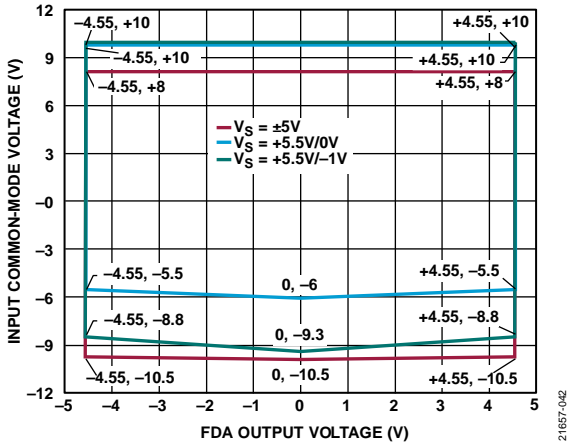

Figure 35. Input Common-Mode Voltage vs. FDA Output Voltage, $G = 0.454$, Differential Input

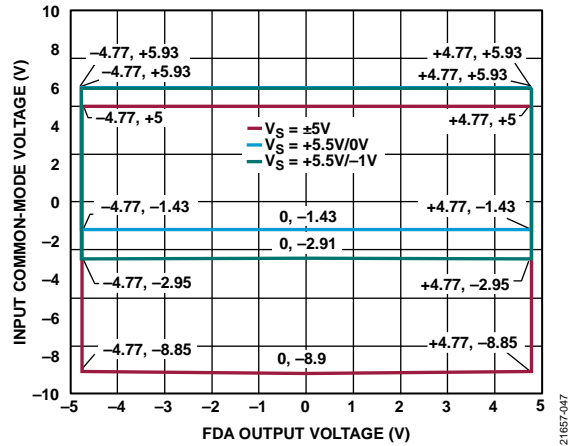

Figure 37. Input Common-Mode Voltage vs. FDA Output Voltage, $G = 1.9$, Differential Input

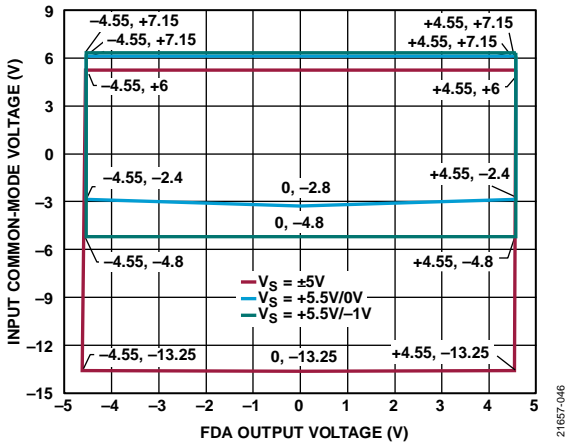

Figure 36. Input Common-Mode Voltage vs. FDA Output Voltage, $G = 0.909$, Differential Input

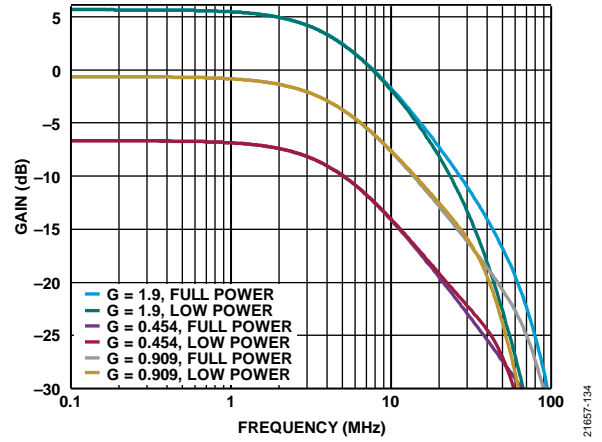

Figure 38. Small Signal Frequency Response and 0.1 dB Flatness for $G = 1.9$, $G = 0.454$, and $G = 0.909$ at Full Power and Low Power

TERMINOLOGY

Integral Nonlinearity (INL) Error

INL error is the deviation of each individual code from a line drawn from negative full scale through positive full scale. The point used as negative full scale occurs $\frac{1}{2}$ LSB before the first code transition. Positive full scale is defined as a level $1\frac{1}{2}$ LSB beyond the last code transition. The deviation is measured from the middle of each code to the true straight line (see Figure 39).

Differential Nonlinearity (DNL) Error

In an ideal ADC, code transitions are 1 LSB apart. DNL is the maximum deviation from this ideal value. DNL error is often specified in terms of resolution for which no missing codes are guaranteed.

Offset Error

Offset error is the difference between the ideal midscale voltage, 0 V, and the actual voltage producing the midscale output code, 0 LSB.

Gain Error

The first transition (from 100 ... 00 to 100 ... 01) occurs at a level $\frac{1}{2}$ LSB above nominal negative full scale. The last transition (from 011 ... 10 to 011 ... 11) occurs for an analog voltage $1\frac{1}{2}$ LSB below the nominal full scale. The gain error is the deviation of the difference between the actual level of the last transition and the actual level of the first transition from the difference between the ideal levels.

Spurious-Free Dynamic Range (SFDR)

SFDR is the difference, in decibels (dB), between the rms amplitude of the input signal and the peak spurious signal, including harmonics.

Effective Number of Bits (ENOB)

ENOB is a measurement of the resolution with a sine wave input. ENOB is related to SINAD as follows:

$$ENOB = (SINAD_{dB} - 1.76)/6.02$$

ENOB is expressed in bits.

Total Harmonic Distortion (THD)

THD is the ratio of the rms sum of the first five harmonic components to the rms value of a full-scale input signal and is expressed in decibels.

Dynamic Range

Dynamic range is the ratio of the rms value of the full scale to the total rms noise measured. The value for dynamic range is expressed in decibels. Dynamic range is measured with a signal at -60 dBFS so that the range includes all noise sources and DNL artifacts.

Signal-to-Noise Ratio (SNR)

SNR is the ratio of the rms value of the actual input signal to the rms sum of all other spectral components below the Nyquist frequency, excluding harmonics and dc. The value for SNR is expressed in decibels.

Signal-to-Noise-and-Distortion Ratio (SINAD)

SINAD is the ratio of the rms value of the actual input signal to the rms sum of all other spectral components that are less than the Nyquist frequency, including harmonics but excluding dc. The value of SINAD is expressed in decibels.

Aperture Delay

Aperture delay is the measure of the acquisition performance and is the time between the rising edge of the CNV input and when the input signal is held for a conversion.

Transient Response

Transient response is the time required for the ADC to acquire a full-scale input step to ± 1 LSB accuracy.

Common-Mode Rejection Ratio (CMRR)

CMRR is the ratio of the power in the ADC output at the frequency, f , to the power of a 200 mV p-p sine wave applied to the input common-mode voltage of f .

$$CMRR \text{ (dB)} = 10\log(P_{ADC_IN}/P_{ADC_OUT})$$

where:

P_{ADC_IN} is the common-mode power at f applied to the inputs.

P_{ADC_OUT} is the power at f in the ADC output.

Power Supply Rejection Ratio (PSRR)

PSRR is the ratio of the power in the ADC output at f to the power of a 200 mV p-p sine wave applied to the ADC VDD supply of f .

$$PSRR \text{ (dB)} = 10 \log(P_{VDD_IN}/P_{ADC_OUT})$$

where:

P_{VDD_IN} is the power at f at the VDD pin.

P_{ADC_OUT} is the power at f in the ADC output.

THEORY OF OPERATION

CIRCUIT INFORMATION

The ADAQ4003 SiP is a fast, precision DAQ signal chain that uses a SAR architecture. As shown in Figure 1, the ADAQ4003 μ Module DAQ solution contains a high bandwidth, fully differential, ADC driver, a low noise reference buffer, and an 18-bit SAR ADC, along with the critical precision passive components required to achieve optimized performance with pin-selectable gain options of 0.454, 0.909, 1, or 1.9. All active components including *i*Passives thin film resistors with $\pm 0.005\%$ matching in the circuit are designed by Analog Devices, which are factory calibrated to achieve a high degree of specified accuracy and minimize temperature dependent error sources.

The ADAQ4003 is capable of converting 2,000,000 samples per second (2 MSPS). The ADAQ4003 has a valid first conversion after being powered down for long periods that can reduce power consumed in applications where the ADC does not convert constantly.

The ADAQ4003 offers a significant reduction in form factor and total cost of ownership compared to traditional discrete signal chains from a selection of individual components, size of PCB, and manufacturing perspective, while still providing flexibility to adapt to a wide array of applications.

The ADAQ4003 incorporates a fully differential, high speed ADC driver with integrated precision resistors. The precision resistors can be pin strapped to achieve different gains for the fully differential ADC driver, which allows the user to match the input signal range. The fully ADC driver can be used in a differential manner or to perform a single-ended to differential conversion for a single-ended input.

The fast conversion time of the ADAQ4003, along with turbo mode, allows low clock rates to read back conversions, even when running at its maximum throughput rate. Note that for the ADAQ4003, the full throughput rate of 2 MSPS can be achieved only with turbo mode enabled. Because the ADAQ4003 has on-board conversion clocks, the serial clock (SCK) is not required for the conversion process.

The ADAQ4003 interfaces to any 1.8 V to 5 V digital logic family. The device is housed in a 7 mm \times 7 mm, 0.80 mm pitch 49-ball CSP_BGA that provides significant space savings and allows flexible configurations.

TRANSFER FUNCTIONS

The ideal transfer characteristics for the ADAQ4003 are shown in Figure 39 and Table 10.

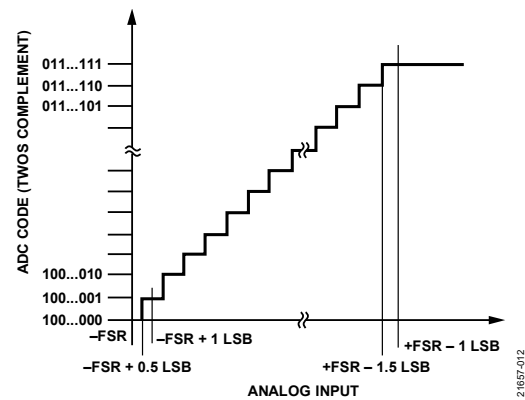

Figure 39. ADC Ideal Transfer Function (FSR Is Full-Scale Range)

Table 10. Output Codes and Ideal Input Voltages

| Description | Analog Inputs | | Digital Output Code ¹ (Twos Complement, Hex) |
|------------------|--|---|--|
| | Span Compression Disabled | Span Compression Enabled | |
| FSR – 1 LSB | $(131,071 \times V_{REF}) / (131,072 \times G)$ | $(131,071 \times 0.8 \times V_{REF}) / (131,072 \times G)$ | 0x1FFFF ² |
| Midscale + 1 LSB | $V_{REF} / (131,072 \times G)$ | $0.8 \times V_{REF} / (131,072 \times G)$ | 0x00001 |
| Midscale | 0 V | 0 V | 0x00000 |
| Midscale – 1 LSB | $-V_{REF} / (131,072 \times G)$ | $-0.8 \times V_{REF} / (131,072 \times G)$ | 0x3FFFF |
| –FSR + 1 LSB | $-(131,071 \times V_{REF}) / (131,072 \times G)$ | $-(131,071 \times 0.8 \times V_{REF}) / (131,072 \times G)$ | 0x20001 |
| –FSR | $-V_{REF} \times G$ | $-0.8 \times V_{REF} \times G$ | 0x20000 ³ |

¹ This output code assumes that the negative input, IN₋, of the ADC driver is being driven.

² This output code is also the code for an overranged analog input (IN₊ – IN₋ above V_{REF} with the span compression disabled and above $0.8 \times V_{REF}$ with the span compression enabled).

³ This output code is also the code for an underranged analog input (IN₊ – IN₋ below $-V_{REF}$ with the span compression disabled and above $0.8 \times V_{REF}$ with the span compression enabled).

APPLICATIONS INFORMATION

TYPICAL APPLICATION DIAGRAMS

Figure 40 through Figure 47 show the recommended connection diagrams for the ADAQ4003 when applying a single-ended and differential input signal for four different gain options with respect to ground reference.

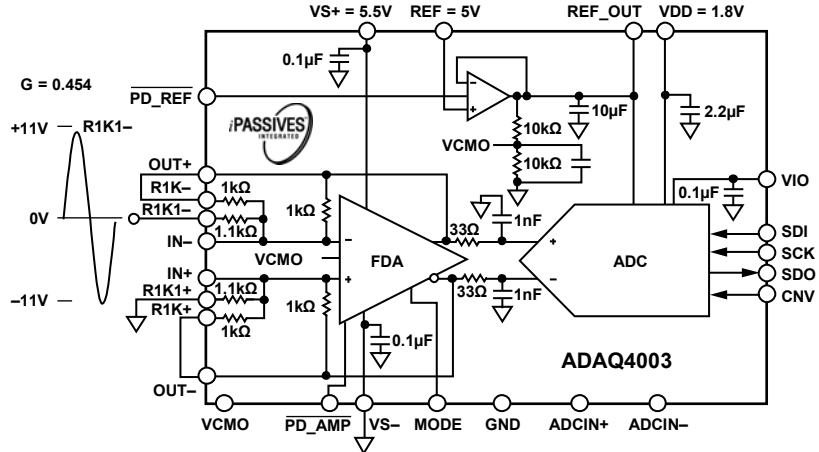

Figure 40. Single-Ended to Differential Configuration with $G = 0.454$

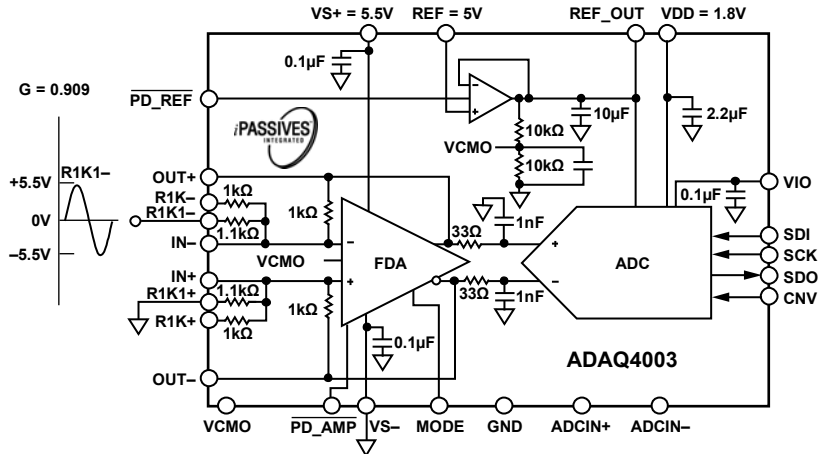

Figure 41. Single-Ended to Differential Configuration with $G = 0.909$

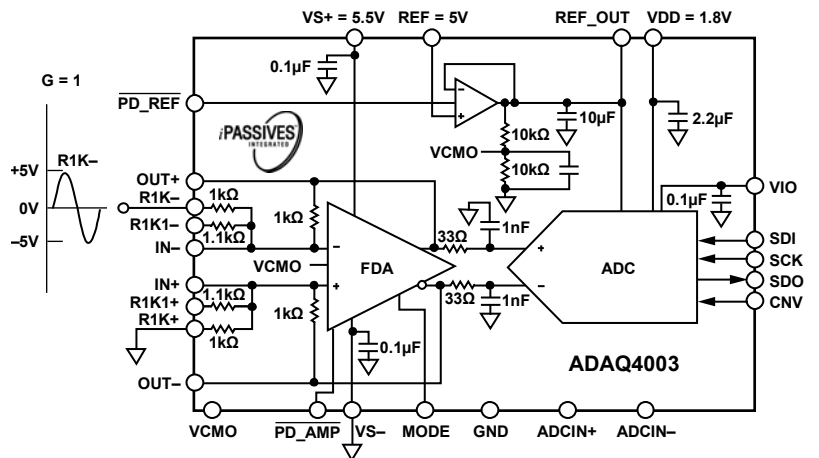

Figure 42. Single-Ended to Differential Configuration with $G = 1$

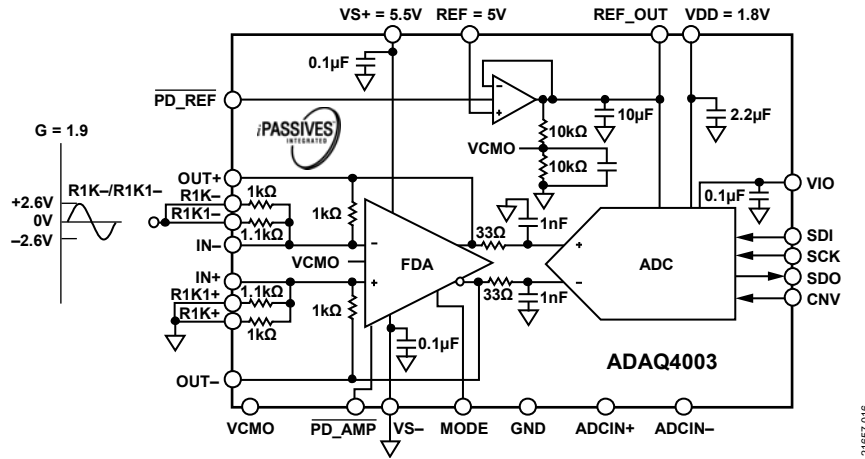

Figure 43. Single-Ended to Differential Configuration with $G = 1.9$

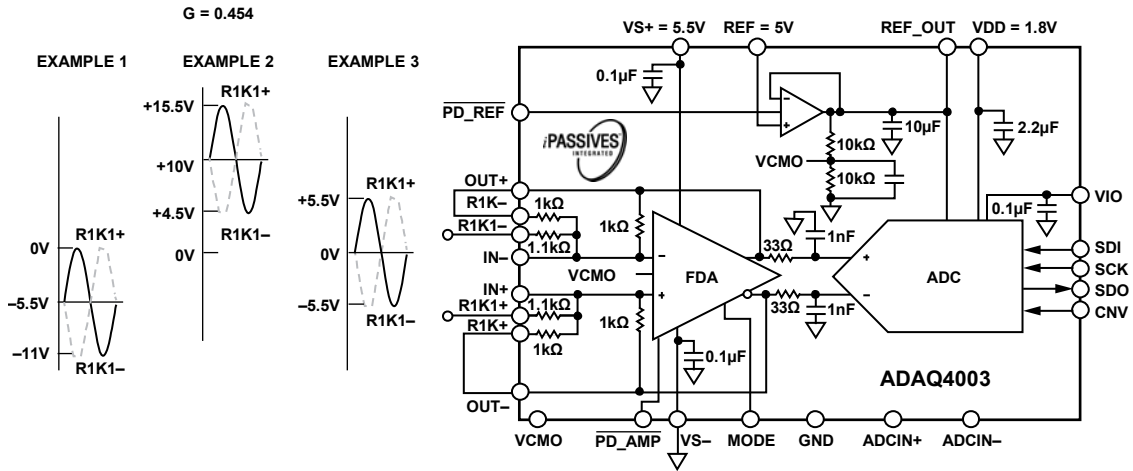

Figure 44. Differential Configuration with $G = 0.454$

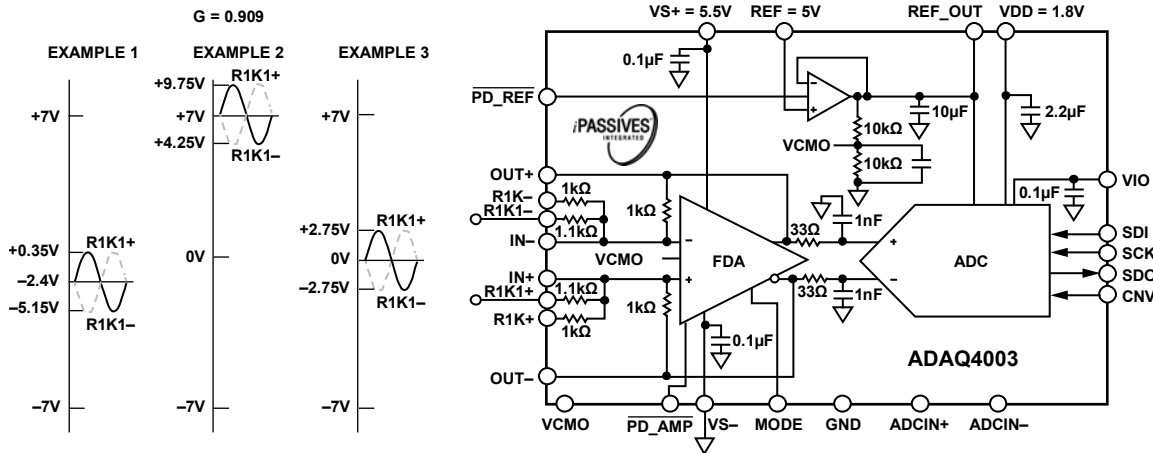

Figure 45. Differential Configuration with $G = 0.909$

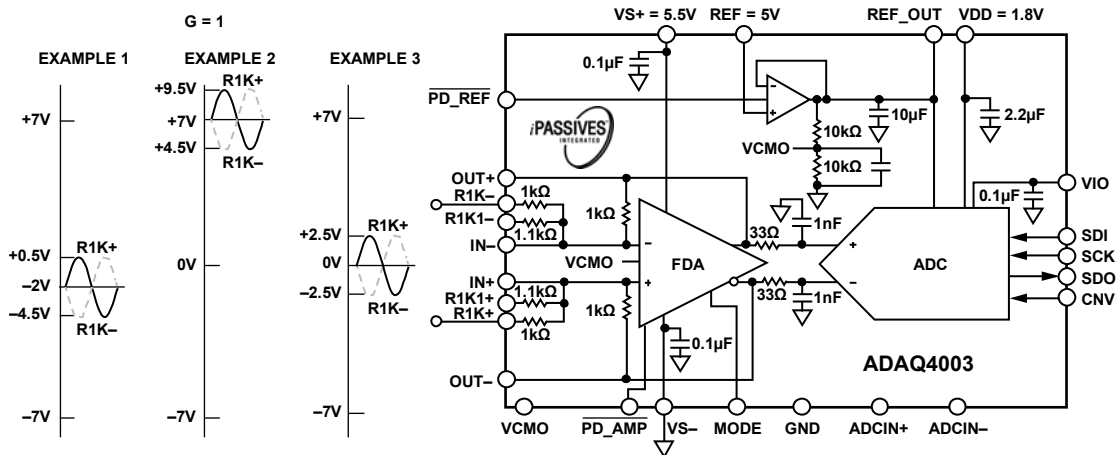

Figure 46. Differential Configuration with $G = 1$

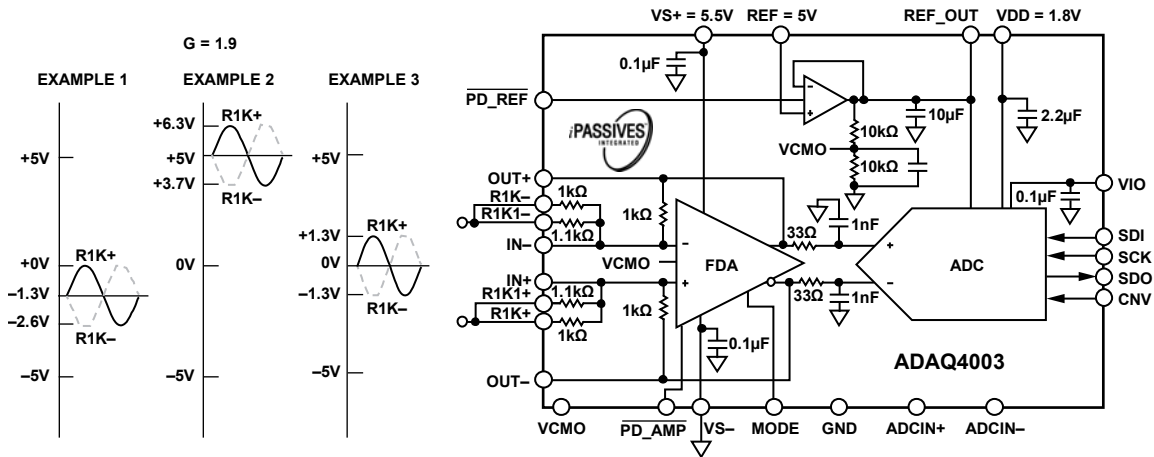

Figure 47. Differential Configuration with $G = 1.9$

ANALOG INPUTS

High Frequency Input Signals

The ADAQ4003 ac performance over a wide input frequency range using a 5 V reference voltage is shown in Figure 21 and Figure 24. The ADAQ4003 maintains exceptional ac performance for input frequencies up to the Nyquist frequency with minimal performance degradation.

EASE OF DRIVE FEATURES

Input Span Compression

The ADAQ4003 includes a span compression feature that increases the headroom and footroom available to the ADC driver by reducing the input range by 10% from the top and bottom of the range while still accessing all available ADC codes. The SNR decreases by approximately 1.9 dB ($20 \times \log(8/10)$) for the reduced input range when span compression is enabled. Span compression is disabled by default but can be enabled by writing to the relevant register bit (see the Digital Interface section).

ADC High-Z Mode

The ADAQ4003 incorporates ADC high-Z mode, which reduces the nonlinear charge kickback when the capacitor DAC switches back to the input at the start of the acquisition. The ADC high-Z mode is disabled by default but can be enabled by writing to the register (see Table 14). Disable high-Z mode for input frequencies above 100 kHz or when multiplexing.

Driving the ADAQ4003 Using a High Impedance PGIA

The majority of instrumentation and programmable gain instrumentation amplifiers (PGIAs) are single-ended output, which cannot directly drive the fully differential data acquisition signal chain. However, the LTC6373 PGIA offers fully differential outputs, low noise, low distortion, and high bandwidth. The LTC6373 is dc-coupled on the input and the output with programmable gain settings (using the A2, A1, and A0 pins). These features enable the LTC6373 to drive the ADAQ4003 directly in many signal chain applications without sacrificing precision performance.

In Figure 50, the LTC6373 is used in a differential input to differential output configuration with dual supplies of $\pm 15V$. The LTC6373 can also be used in a single-ended input to differential output configuration, if required. The LTC6373 is directly driving the ADAQ4003 with its gain set as 0.454. The V_{OCM} pin of LTC6373 is connected to ground and its outputs swing between $-5.5V$ and $+5.5V$ (opposite in phase). The FDA of ADAQ4003 level shifts the outputs of the LTC6373 to match the desired input common mode of the ADAQ4003 and provides the signal amplitude necessary to utilize the maximum $2 \times V_{REF}$ peak-to-peak differential signal range of the ADC inside the ADAQ4003 μ Module. Figure 48 and Figure 49 show the SNR and THD performance using various gain settings of the LTC6373 for the circuit configuration shown in Figure 50.

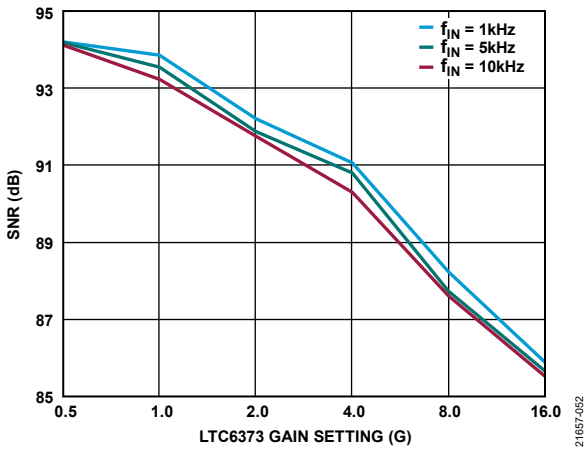

Figure 48. SNR vs. LTC6373 Gain Setting, LTC6373 Driving the ADAQ4003 (Gain = 0.454)

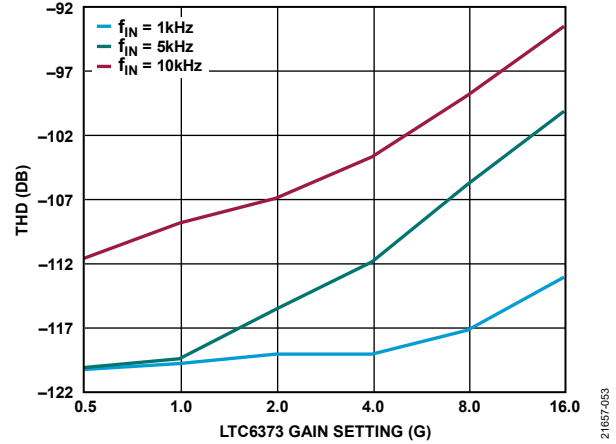

Figure 49. THD vs. LTC6373 Gain Setting, LTC6373 Driving the ADAQ4003 (Gain = 0.454)

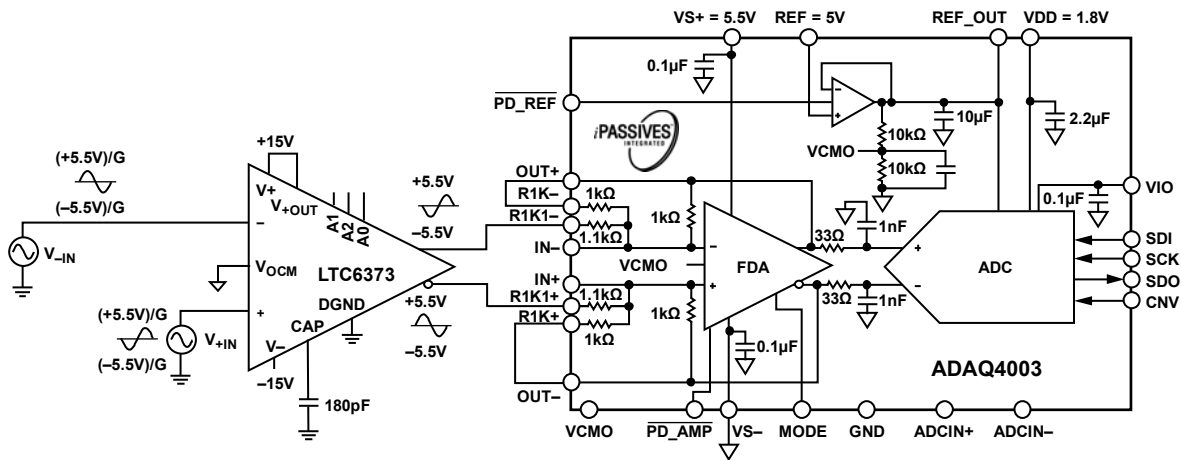

Figure 50. LTC6373 Driving ADAQ4003 (G = 0.454)

VOLTAGE REFERENCE INPUT

The ADAQ4003 voltage reference input (REF) is the noninverting node of the on board, low noise reference buffer. The reference buffer is included to optimally drive the dynamic input impedance of the SAR ADC reference node.

Also housed in the ADAQ4003 is a 10 μF decoupling capacitor that is ideally laid out within the device. This decoupling capacitor is a required piece of the SAR architecture. The REF_OUT capacitor is not just a bypass capacitor. This capacitor is part of the SAR ADC that cannot fit on the silicon simply. During the bit decision process, because the bits are settled in a few tens of nanoseconds or faster, the storage capacitor replenishes the charge of the internal capacitive DAC. As the binary bit weighted conversion is processed, small chunks of charge are taken from the 10 μF capacitor. The internal capacitor array is a fraction of the size of the decoupling capacitor, but this large value storage capacitor is required to meet the SAR bit decision settling time. There is no need for an additional lower value ceramic decoupling capacitor (for example, 100 nF) between the REF_OUT and GND pins.

The reference value sets the maximum ADC input voltage that the SAR capacitor array can quantize. The reference buffer is set in the unity-gain configuration. Therefore, the user sets the reference voltage value with the REF pin and observes this value at the REF_OUT pin. The user is responsible for selecting a reference voltage value that is appropriate for the system under design. Allowable reference values range from 2.4 V to 5.1 V. However, do not violate the input common-mode voltage range specification of the reference buffer. With the inclusion of the reference buffer, the user can implement a much lower power reference source than many traditional SAR ADC signal chains because the reference source drives a high impedance node instead of the dynamic load of the SAR capacitor array. Root sum square the reference buffer noise with the reference source noise to arrive at a total noise estimate. Generally, the reference buffer has a noise density much less than that of the reference source.

For highest performance and lower drift, use a reference such as the [ADR4550](#), or use a low power reference such as the [ADR3450](#) at the expense of a decrease in the noise performance.

POWER SUPPLY (POWER TREE)

The ADAQ4003 uses four power supply pins: an ADC driver positive (V_{S+}) and negative supply (V_{S-}), a core ADC supply (VDD), a digital input and output interface supply (VIO). VIO allows direct interface with any logic among 1.8 V, 2.5 V, 3 V, or 5 V. To reduce the number of supplies needed, VIO and VDD can be tied together for 1.8 V operation. A combination of the [ADP5070](#) (dual, high performance dc-to-dc switching regulator), the [LT3032](#) (dual, low noise, positive and negative, low dropout voltage linear regulator), and the [LT3023](#) (dual, micropower, low noise, low dropout regulator) can generate independently regulated positive and negative rails for all four power supply pins, including ± 15 V rails for any additional signal conditioning. Refer to the [EVAL-ADAQ4003FMCZ](#) user guide for details. The ADAQ4003 is insensitive to power supply variations (PSRR) over a wide frequency range, as shown in Figure 33.

The ADAQ4003 ADC powers down automatically at the end of each conversion phase. Therefore, the power scales linearly with the sampling rate. This feature makes the device ideal for low sampling rates (even a few samples per second) and battery-powered applications. Figure 32 shows the ADAQ4003 total power dissipation and individual power dissipation for each rail.

DIGITAL INTERFACE

Although the ADAQ4003 has a reduced number of pins, the device offers flexibility in its serial interface modes. The ADAQ4003 can also be programmed via 16-bit SPI writes to the configuration registers.

When in $\overline{\text{CS}}$ mode, the ADAQ4003 is compatible with SPI, QSPI[™], MICROWIRE[®], digital hosts, and digital signal processors (DSPs). In this mode, the ADAQ4003 can use either a 3-wire or 4-wire interface. A 3-wire interface using the CNV, SCK, and SDO signals minimizes wiring connections, which is useful in isolated applications. A 4-wire interface using the SDI, CNV, SCK, and SDO signals allows CNV, which initiates the conversions, to be independent of the readback timing (SDI). This interface is useful in low jitter sampling or simultaneous sampling applications.

The ADAQ4003 provides a daisy-chain feature using the SDI for cascading multiple ADCs on a single data line, similar to a shift register.

The mode in which the ADAQ4003 operates depends on the SDI level when the CNV rising edge occurs. $\overline{\text{CS}}$ mode is selected if SDI is high, and daisy-chain mode is selected if SDI is low. The SDI hold time is such that when SDI and CNV are connected together, daisy-chain mode is automatically selected.

In either 3-wire or 4-wire mode, the ADAQ4003 offers the option of forcing a start bit in front of the data bits. This start bit can be used as a busy signal indicator to interrupt the digital

host and trigger the data reading. Otherwise, without a busy indicator, the user must time out the maximum conversion time prior to readback.

The busy indicator feature is enabled in \overline{CS} mode if CNV or SDI is low when the ADC conversion ends.

The state of SDO on power-up is either low or high-Z depending on the states of CNV and SDI (see Table 11).

Table 11. State of SDO on Power-Up

| CNV | SDI | SDO |
|-----|-----|--------|
| 0 | 0 | Low |
| 0 | 1 | Low |
| 1 | 0 | Low |
| 1 | 1 | High-Z |

The ADAQ4003 has a turbo mode capability in both 3-wire and 4-wire mode. Turbo mode is enabled by writing to the configuration register and replaces the busy indicator feature when enabled. Turbo mode allows a slower SPI clock rate, making interfacing simpler. The maximum throughput of 2 MSPS for the ADAQ4003 can be achieved only with turbo mode enabled and a minimum SCK rate of 75 MHz. The SCK rate must be sufficiently fast to ensure the conversion result is clocked out before another conversion initiates. The minimum required SCK rate for an application can be derived based on the sample period (t_{CYC}), the number of bits that must be read (including the data and optional status bits), and the digital interface mode used. Timing diagrams and explanations for each digital interface mode are given in the digital modes of operation sections (see the \overline{CS} Mode, 3-Wire Turbo Mode section and the \overline{CS} Mode, 4-Wire with Busy Indicator section).

Status bits can also be clocked out at the end of the conversion data if the status bits are enabled in the configuration register. The six status bits are described in Table 12.

The ADAQ4003 is configured by 16-bit SPI writes to the desired configuration register. The 16-bit word can be written via the SDI line while CNV is held low. The 16-bit word consists of an 8-bit header and 8-bit register data. For isolated systems, the ADuM141D is recommended, which can support the 75 MHz SCK rate required to run the ADAQ4003 at its full throughput of 2 MSPS.

REGISTER READ AND WRITE FUNCTIONALITY

The ADAQ4003 register bits are programmable, and the bits default statuses are listed in Table 12. The register map is shown in

Table 14. The \overline{OV} clamp flag is a read only sticky bit, and this bit is cleared only if the register is read and the overvoltage condition is no longer present. The \overline{OV} clamp flag gives an indication of the overvoltage condition when this bit is set to 0.

Table 12. Register Bits

| Register Bits | Default Status |
|----------------------------|-------------------------------|
| \overline{OV} Clamp Flag | 1 bit, 1 = inactive (default) |
| Span Compression | 1 bit, 0 = disabled (default) |
| High-Z Mode | 1 bit, 0 = disabled (default) |
| Turbo Mode | 1 bit, 0 = disabled (default) |
| Enable Six Status Bits | 1 bit, 0 = disabled (default) |

All access to the register map must start with a write to the 8-bit command register in the SPI interface block. The ADAQ4003 ignores all 1s until the first 0 is clocked in (represented by WEN in Figure 51, Figure 52, and Table 13). The value loaded into the command register is always 0 followed by seven command bits. This command determines whether that operation is a write or a read. The ADAQ4003 command register is listed in Table 13.

Table 13. Command Register

| Bit 7 | Bit 6 | Bit 5 | Bit 4 | Bit 3 | Bit 2 | Bit 1 | Bit 0 |
|------------------|-------------------|-------|-------|-------|-------|-------|-------|
| \overline{WEN} | R/ \overline{W} | 0 | 1 | 0 | 1 | 0 | 0 |

All register read and writes must occur while CNV is low. Data on SDI is clocked in on the rising edge of SCK. Data on SDO is clocked out on the falling edge of SCK. At the end of the data transfer, SDO is put in a high impedance state on the rising edge of CNV if daisy-chain mode is not enabled. If daisy-chain mode is enabled, SDO goes low on the rising edge of CNV. Register reads are not allowed in daisy-chain mode.

A register write requires three signal lines: SCK, CNV, and SDI. During a register write to read the current conversion results on SDO, the CNV pin must be brought low after the conversion completes. Otherwise, the conversion results may be incorrect on SDO. However, the register write occurs regardless.

The LSB of each configuration register is reserved because a user reading 16-bit conversion data may be limited to a 16-bit SPI frame. The state of SDI on the last bit in the SDI frame may be the state that then persists when CNV rises. Because interface mode is partly set based on the SDI state when CNV rises, in this scenario, the user may need to set the final SDI state.

The timing diagrams in Figure 51 through Figure 53 show how data is read and written when the ADAQ4003 is configured in register read, write, and daisy-chain mode.

Table 14. Register Map

| ADDR[1:0] | Bit 7 | Bit 6 | Bit 5 | Bit 4 | Bit 3 | Bit 2 | Bit 1 | Bit 0 | Reset |
|-----------|----------|----------|----------|------------------------|------------------|-------------|------------|---|-------|
| 0x0 | Reserved | Reserved | Reserved | Enable six status bits | Span compression | High-Z mode | Turbo mode | \overline{OV} clamp flag (read only sticky bit) | 0xE1 |

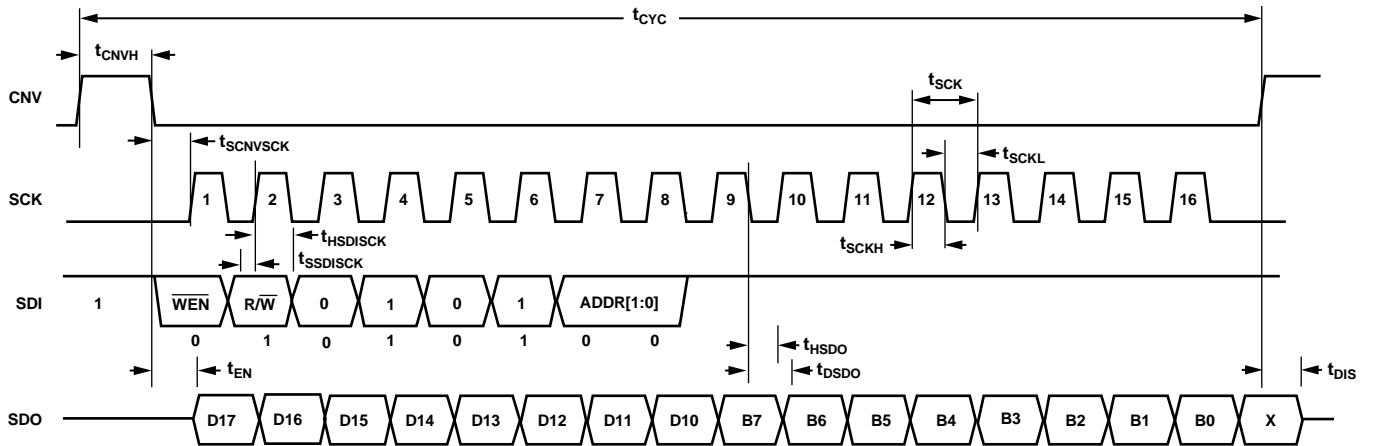
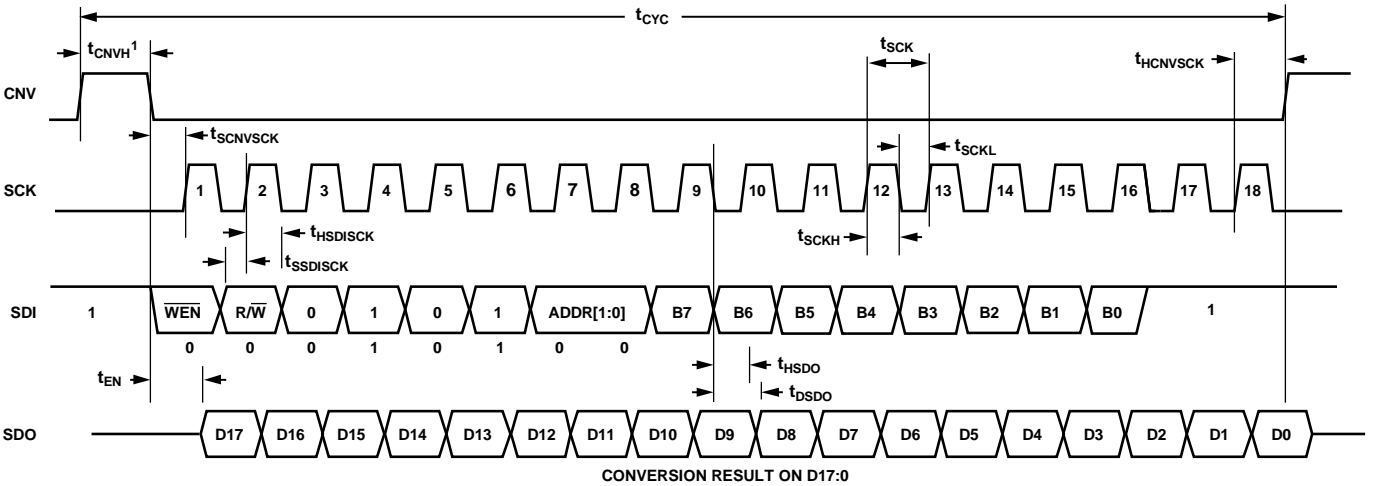

Figure 51. Register Read Timing Diagram



CONVERSION RESULT ON D17:0

¹THE USER MUST WAIT t_{CONV} TIME WHEN READING BACK THE CONVERSION RESULT AND DOING A REGISTER WRITE AT THE SAME TIME.

Figure 52. Register Write Timing Diagram

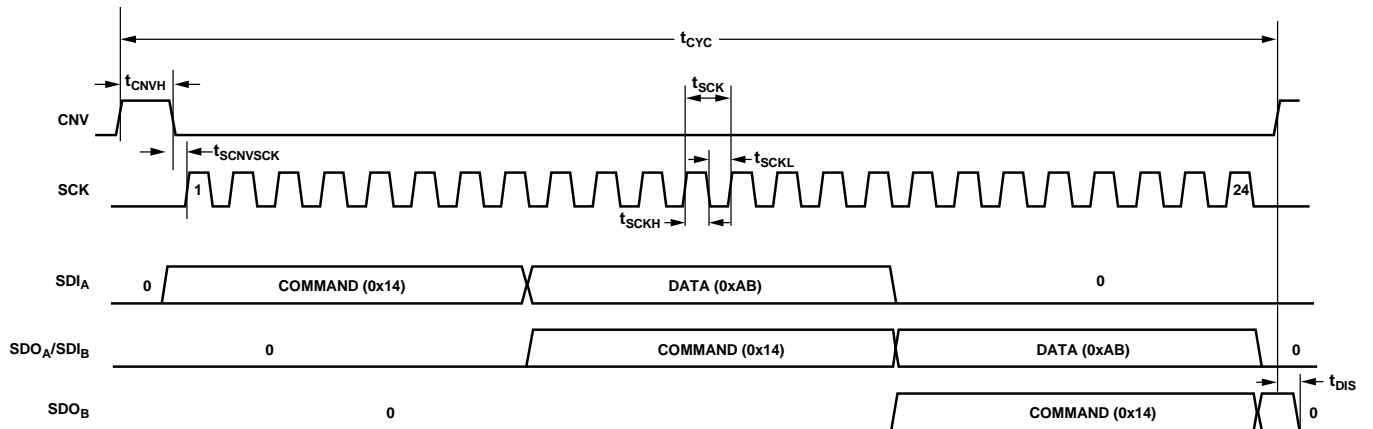

Figure 53. Register Write Timing Diagram, Daisy-Chain Mode

STATUS WORD

The 6-bit status word can be appended to the end of a conversion result, and the default conditions of these bits are shown in Table 15. The status bits must be enabled in the register setting. When the OV clamp flag is 0, this bit indicates an overvoltage condition. The OV clamp flag status bit updates on a per conversion basis.

The SDO line returns to high impedance after the sixth status bit is clocked out (except in daisy-chain mode). The user is not required to clock out all status bits to start the next conversion. The serial interface timing for \overline{CS} mode, 3-wire without busy indicator, including status bits, is shown in Figure 54.

Table 15. Status Bits (Default Conditions)

| Bit 5 | Bit 4 | Bit 3 | Bit 2 | Bit 1 | Bit 0 |
|---------------|------------------|-------------|------------|----------|----------|
| OV clamp flag | Span compression | High-Z mode | Turbo mode | Reserved | Reserved |

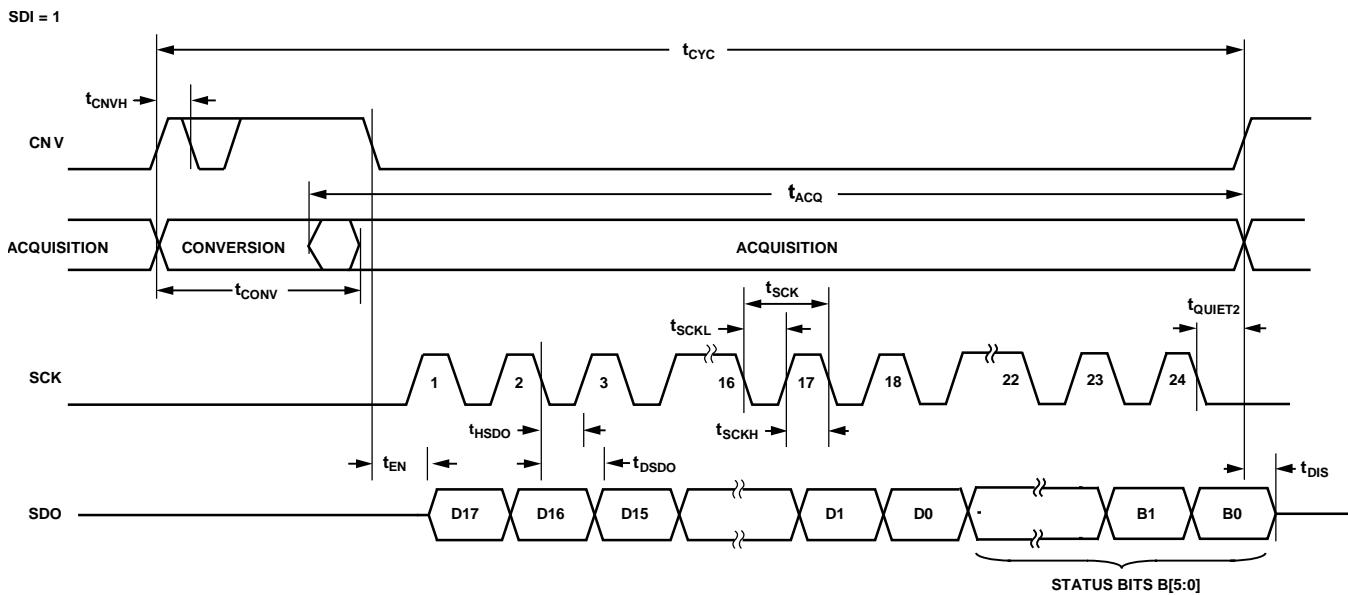

Figure 54. \overline{CS} Mode, 3-Wire Without Busy Indicator Serial Interface Timing Diagram Including Status Bits (SDI High)

21857-024

CS MODE, 3-WIRE TURBO MODE

This mode is typically used when a single ADAQ4003 device is connected to an SPI-compatible digital host. This mode provides additional time during the end of the ADC conversion process to clock out the previous conversion result, providing a lower SCK rate. The ADAQ4003 can achieve a throughput rate of 2 MSPS only when turbo mode is enabled and using a minimum SCK rate of 75 MHz. The connection diagram is shown in Figure 55, and the corresponding timing diagram is shown in Figure 56.

To enable turbo mode, set the turbo mode enable bit in the configuration register to 1 (see Table 12). This mode replaces the 3-wire with busy indicator mode by programming the turbo mode bit, Bit 1 (see Table 14). Writing to the user configuration register requires SDI to be connected to the digital host (see the Register Read and Write Functionality section). When turbo mode is enabled, the conversion result read on SDO corresponds to the result of the previous conversion.

When performing conversions in this mode, SDI must be held high, and a CNV rising edge initiates a conversion and forces

SDO to high impedance. The user must wait the t_{QUIET1} time after CNV is brought high before bringing CNV low to clock out the previous conversion result. When the conversion is complete (after t_{CONV}), the ADAQ4003 enters the acquisition phase and powers down. The user must also wait the t_{QUIET2} time after the last falling edge of SCK to when CNV is brought high.

When CNV goes low, the MSB is output to SDO. The remaining data bits are clocked by subsequent SCK falling edges. The data is valid on both SCK edges. Although the rising edge can capture the data, a digital host using the SCK falling edge allows a faster reading rate, provided it has an acceptable hold time, as dictated by t_{HSDO} (see Table 3). If the status bits are not enabled, SDO returns to high impedance after the 18th SCK falling edge. If the status bits are enabled, the bits are shifted out on SDO on the 19th through the 24th SCK falling edges (see the Status Word section). SDO returns to high impedance after the 18th SCK falling edge, or when CNV goes high (whichever occurs first). The user must also provide a delay of t_{QUIET2} between the final SCK falling edge and the next CNV rising edge to ensure specified performance.

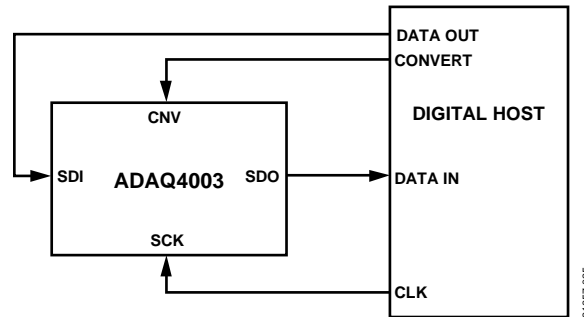

Figure 55. CS Mode, 3-Wire Turbo Mode Connection Diagram (SDI High)

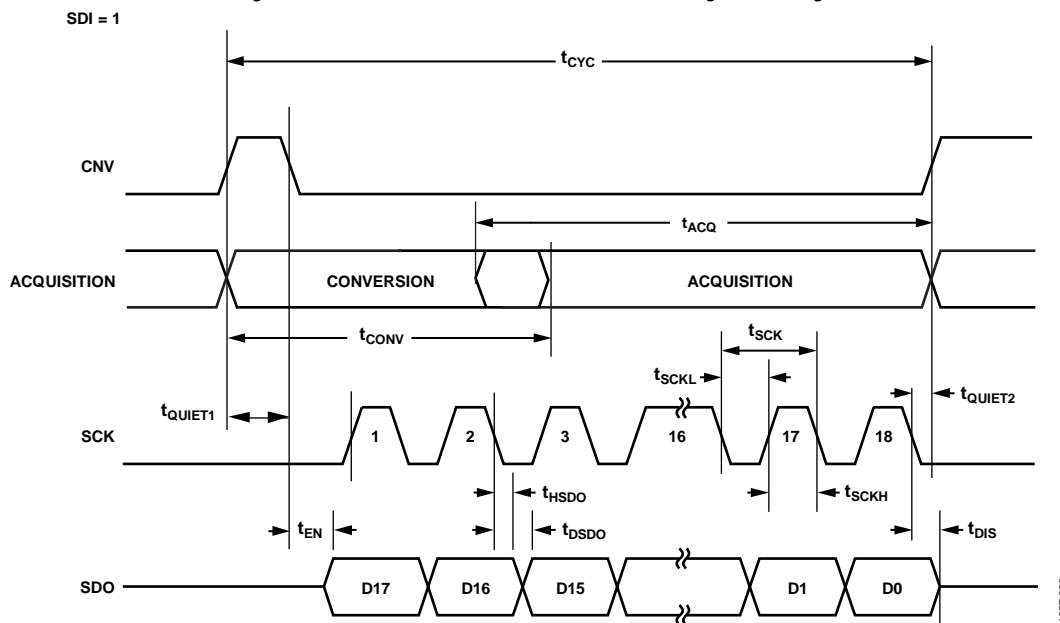

Figure 56. CS Mode, 3-Wire Turbo Mode Serial Interface Timing Diagram (SDI High)

CS MODE, 3-WIRE WITHOUT BUSY INDICATOR

This mode is typically used when a single ADAQ4003 device is connected to an SPI-compatible digital host. The connection diagram is shown in Figure 57, and the corresponding timing diagram is shown in Figure 58.

When SDI is connected to VIO, a rising edge on CNV initiates a conversion, selects the CS mode, and forces SDO to high impedance. After a conversion initiates, it continues until completion irrespective of the state of CNV. This feature can be useful, for instance, to bring CNV low to select other SPI devices, such as analog multiplexers. However, CNV must be returned high before the minimum conversion time elapses and then held high for the maximum possible conversion time to avoid the generation of the busy signal indicator.

When the conversion completes, the ADAQ4003 enters the acquisition phase and powers down. When CNV goes low, the MSB is output onto SDO. The remaining data bits are clocked by subsequent SCK falling edges. The data is valid on both SCK edges. Although the rising edge can capture the data, a digital host using the SCK falling edge allows a faster reading rate, provided that the digital host has an acceptable hold time. After the 18th SCK falling edge or when CNV goes high (whichever occurs first), SDO returns to high impedance.

There must not be any digital activity on SCK during the conversion.

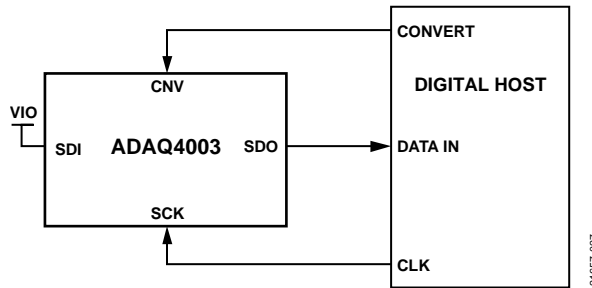

Figure 57. CS Mode, 3-Wire Without Busy Indicator Connection Diagram (SDI High)

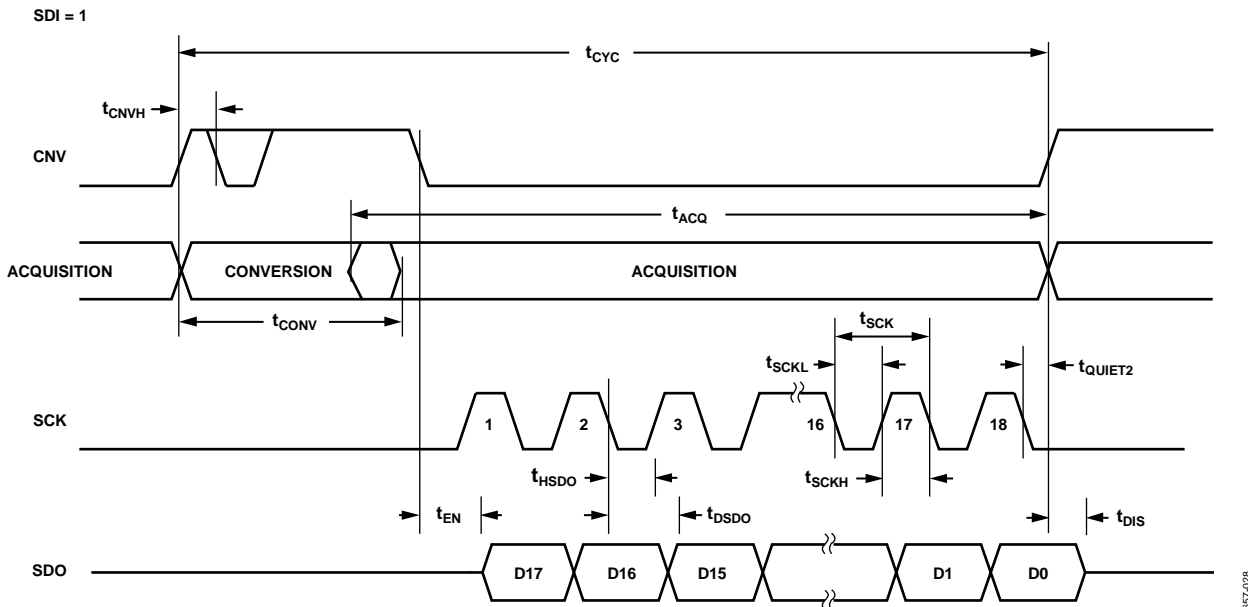

Figure 58. CS Mode, 3-Wire Without Busy Indicator Serial Interface Timing Diagram (SDI High)

CS MODE, 3-WIRE WITH BUSY INDICATOR

This mode is typically used when a single ADAQ4003 device is connected to an SPI-compatible digital host with an interrupt input (IRQ).

The connection diagram is shown in Figure 59, and the corresponding timing diagram is shown in Figure 60.

When SDI is connected to VIO, a rising edge on CNV initiates a conversion, selects the CS mode, and forces SDO to high impedance. SDO is maintained in high impedance until the completion of the conversion irrespective of the state of CNV. Prior to the minimum conversion time, CNV can select other SPI devices, such as analog multiplexers. However, CNV must be returned low before the minimum conversion time elapses and then held low for the maximum possible conversion time to guarantee the generation of the busy signal indicator.

When the conversion completes, SDO goes from high impedance to low impedance. With a pull-up resistor of 1 kΩ on the SDO line, this transition can be used as an interrupt signal to initiate the data reading controlled by the digital host. The ADAQ4003 then enters the acquisition phase and powers down. The data bits are then clocked out, MSB first, by subsequent SCK falling edges. The data is valid on both SCK edges. Although the rising edge can capture the data, a digital host using the SCK falling edge allows a faster reading rate, provided that the digital host has an acceptable hold time. After the optional 19th SCK falling edge or when CNV goes high (whichever occurs first), SDO returns to high impedance.

If multiple ADAQ4003 devices are selected at the same time, the SDO output pin handles this contention without damage or induced latch-up. Meanwhile, it is recommended to keep this contention as short as possible to limit extra power dissipation.

There must not be any digital activity on the SCK during the conversion.

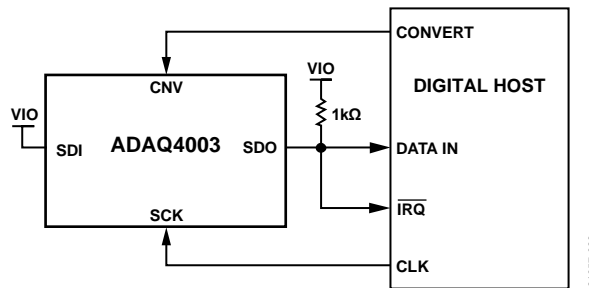

Figure 59. CS Mode, 3-Wire with Busy Indicator Connection Diagram (SDI High)

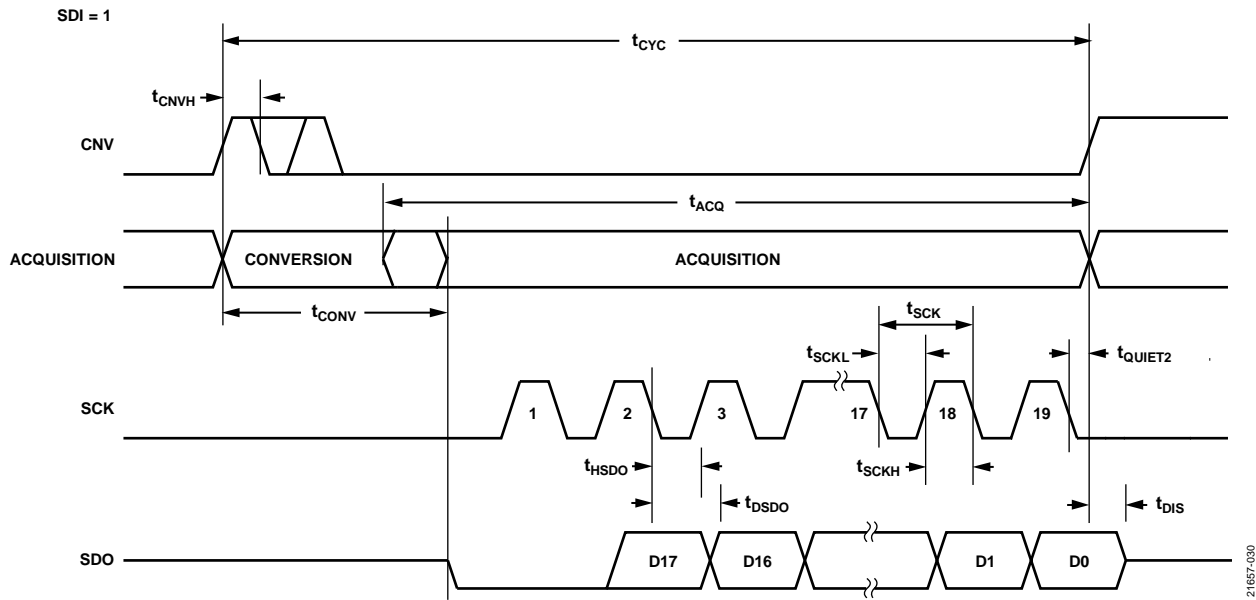

Figure 60. CS Mode, 3-Wire with Busy Indicator Serial Interface Timing Diagram (SDI High)

CS MODE, 4-WIRE TURBO MODE

This mode is typically used when a single ADAQ4003 is connected to an SPI-compatible digital host. This mode provides additional time during the end of the ADC conversion process to clock out the previous conversion result, giving a lower SCK rate. The ADAQ4003 can achieve a throughput rate of 2 MSPS only when turbo mode is enabled and using a minimum SCK rate of 75 MHz. The connection diagram is shown in Figure 61, and the corresponding timing diagram is shown in Figure 62.

This mode replaces the 4-wire with busy indicator mode by programming the turbo mode bit, Bit 1 (see Table 14).

With SDI high, a rising edge on CNV initiates a conversion. The previous conversion data is available to read after the CNV

rising edge. The user must wait t_{QUIET1} after CNV is brought high before bringing SDI low to clock out the previous conversion result. The user must also wait t_{QUIET2} after the last falling edge of SCK to when CNV is brought high.

When the conversion is complete, the ADAQ4003 enters the acquisition phase and powers down. The ADC result can be read by bringing its SDI input low, which consequently outputs the MSB onto SDO. The remaining data bits are then clocked by subsequent SCK falling edges. The data is valid on both SCK edges. Although the rising edge can capture the data, a digital host using the SCK falling edge allows a faster reading rate, provided that the digital host has an acceptable hold time. After the 18th SCK falling edge or when SDI goes high (whichever occurs first), SDO returns to high impedance.

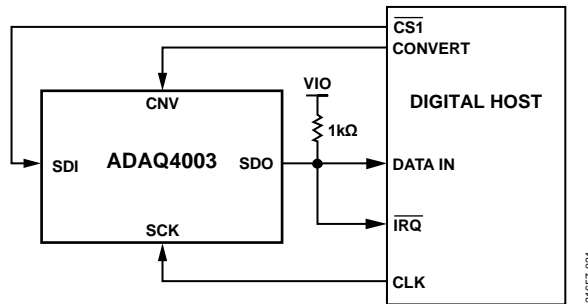

Figure 61. CS Mode, 4-Wire Turbo Mode Connection Diagram

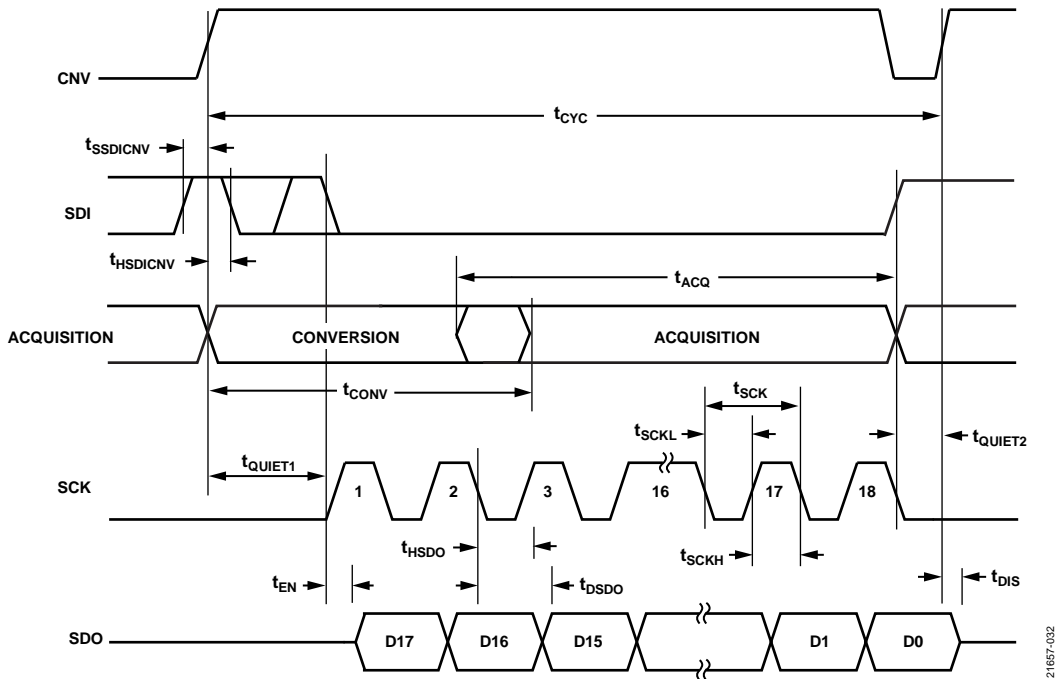

Figure 62. CS Mode, 4-Wire Turbo Mode Timing Diagram

CS MODE, 4-WIRE WITHOUT BUSY INDICATOR

This mode is typically used when multiple ADAQ4003 devices are connected to an SPI-compatible digital host.

A connection diagram example using two ADAQ4003 devices is shown in Figure 63, and the corresponding timing diagram is shown in Figure 64.

With SDI high, a rising edge on CNV initiates a conversion, selects the CS mode, and forces SDO to high impedance. In this mode, CNV must be held high during the conversion phase and the subsequent data readback. If SDI and CNV are low, SDO is driven low. Prior to the minimum conversion time, SDI can select other SPI devices, such as analog multiplexers. However, SDI must be returned high before the minimum

conversion time elapses and then held high for the maximum possible conversion time to avoid the generation of the busy signal indicator.

When the conversion is complete, the ADAQ4003 enters the acquisition phase and powers down. Each ADC result can be read by bringing its SDI input low, which consequently outputs the MSB onto SDO. The remaining data bits are then clocked by subsequent SCK falling edges. The data is valid on both SCK edges. Although the rising edge can capture the data, a digital host using the SCK falling edge allows a faster reading rate, provided that the digital host has an acceptable hold time. After the 18th SCK falling edge or when SDI goes high (whichever occurs first), SDO returns to high impedance and another ADAQ4003 can be read.

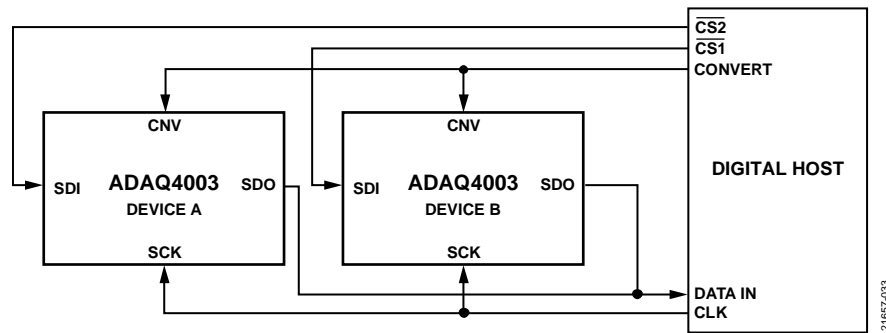

Figure 63. CS Mode, 4-Wire Without Busy Indicator Connection Diagram

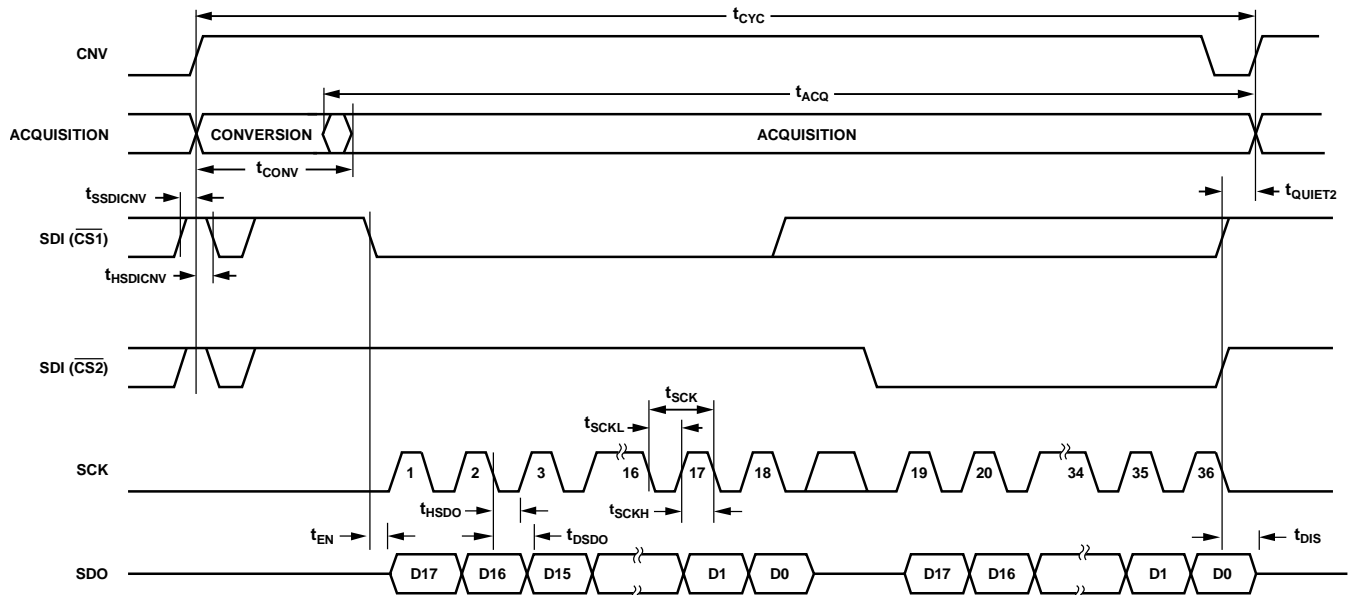

Figure 64. CS Mode, 4-Wire Without Busy Indicator Serial Interface Timing Diagram

CS MODE, 4-WIRE WITH BUSY INDICATOR

This mode is typically used when a single ADAQ4003 device is connected to an SPI-compatible digital host with an interrupt input ($\overline{\text{IRQ}}$), and when it is desired to keep CNV , which samples the analog input, independent of the signal used to select the data reading. This independence is particularly important in applications where low jitter on CNV is desired.

The connection diagram is shown in Figure 65, and the corresponding timing diagram is shown in Figure 66.

With SDI high, a rising edge on CNV initiates a conversion, selects the CS mode, and forces SDO to high impedance. In this mode, CNV must be held high during the conversion phase and the subsequent data readback. If SDI and CNV are low, SDO is driven low. Prior to the minimum conversion time, SDI can select other SPI devices, such as analog multiplexers.

However, SDI must be returned low before the minimum conversion time elapses and then held low for the maximum possible conversion time to guarantee the generation of the busy signal indicator.

When the conversion is complete, SDO goes from high impedance to low impedance. With a pull-up resistor of 1 k Ω on the SDO line, this transition can be used as an interrupt signal to initiate the data readback controlled by the digital host. The ADAQ4003 then enters the acquisition phase and powers down. The data bits are then clocked out, MSB first, by subsequent SCK falling edges. The data is valid on both SCK edges. Although the rising edge can capture the data, a digital host using the SCK falling edge allows a faster reading rate, provided that the digital host has an acceptable hold time. After the optional 19th SCK falling edge or when SDI goes high (whichever occurs first), SDO returns to high impedance.

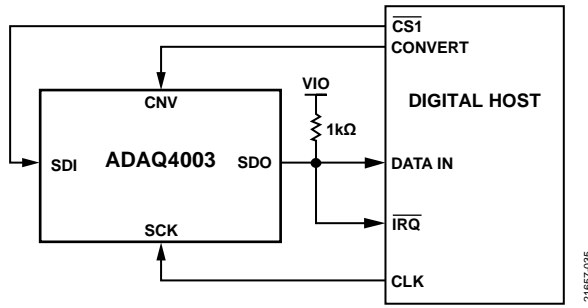

Figure 65. CS Mode, 4-Wire with Busy Indicator Connection Diagram

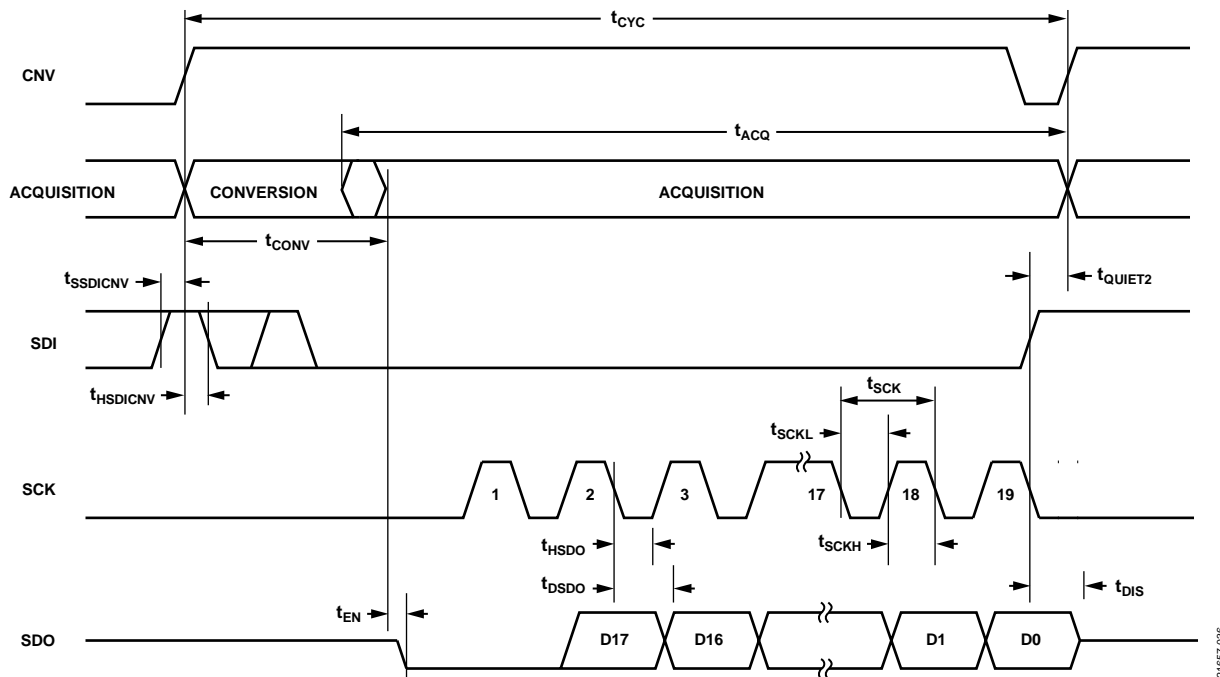

Figure 66. CS Mode, 4-Wire with Busy Indicator Serial Interface Timing Diagram

DAISY-CHAIN MODE

Use this mode to daisy-chain multiple ADAQ4003 devices on a 3-wire or 4-wire serial interface. This feature is useful for reducing component count and wiring connections, for example, in isolated multiconverter applications or for systems with a limited interfacing capacity. Data readback is analogous to clocking a shift register.

A connection diagram example using two ADAQ4003 devices is shown in Figure 67, and the corresponding timing diagram is shown in Figure 68.

When SDI and CNV are low, SDO is driven low. With SCK low, a rising edge on CNV initiates a conversion, selects daisy-chain mode, and disables the busy indicator. In this mode, CNV is held high during the conversion phase and the subsequent data readback. When the conversion is complete, the MSB is output onto SDO, and the ADAQ4003 enters the acquisition phase and powers down. The remaining data bits stored in the internal shift register are clocked out of SDO by subsequent SCK falling edges. For each ADC, SDI feeds the input of the internal shift register and is clocked by the SCK rising edges. Each ADC in the daisy-chain outputs its data MSB

first, and $18 \times N$ clocks are required to read back the N ADCs. The data is valid on both SCK edges. The maximum conversion rate is reduced because of the total readback time.

It is possible to write to each ADC register in daisy-chain mode (see Figure 68). This mode requires 4-wire operation because data is clocked in on the SDI line with CNV held low. The same command byte and register data can be shifted through the entire chain to program all ADCs in the chain with the same register contents, which requires $8 \times (N + 1)$ clocks for N ADCs. It is possible to write different register contents to each ADC in the chain by writing to the furthest ADC in the chain, first using $8 \times (N + 1)$ clocks, and then the second furthest ADC with $8 \times N$ clocks, and so forth until reaching the nearest ADC in the chain, which requires 16 clocks for the command and register data.

It is not possible to read register contents in daisy-chain mode. However, the six status bits can be enabled if the user wants to determine the ADC configuration. Note that enabling the status bits require six extra clocks to clock out the ADC result and the status bits per ADC in the chain. Turbo mode cannot be used in daisy-chain mode.

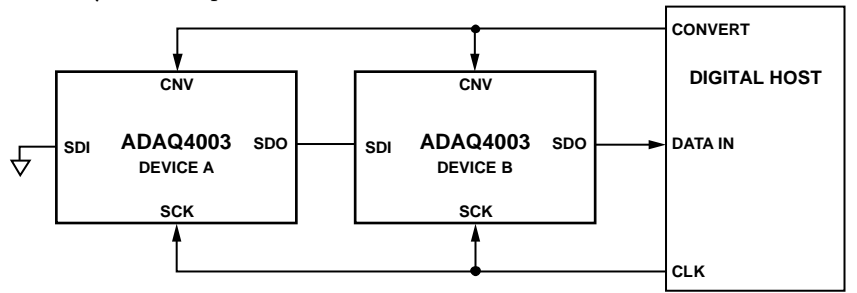

Figure 67. Daisy-Chain Mode Connection Diagram

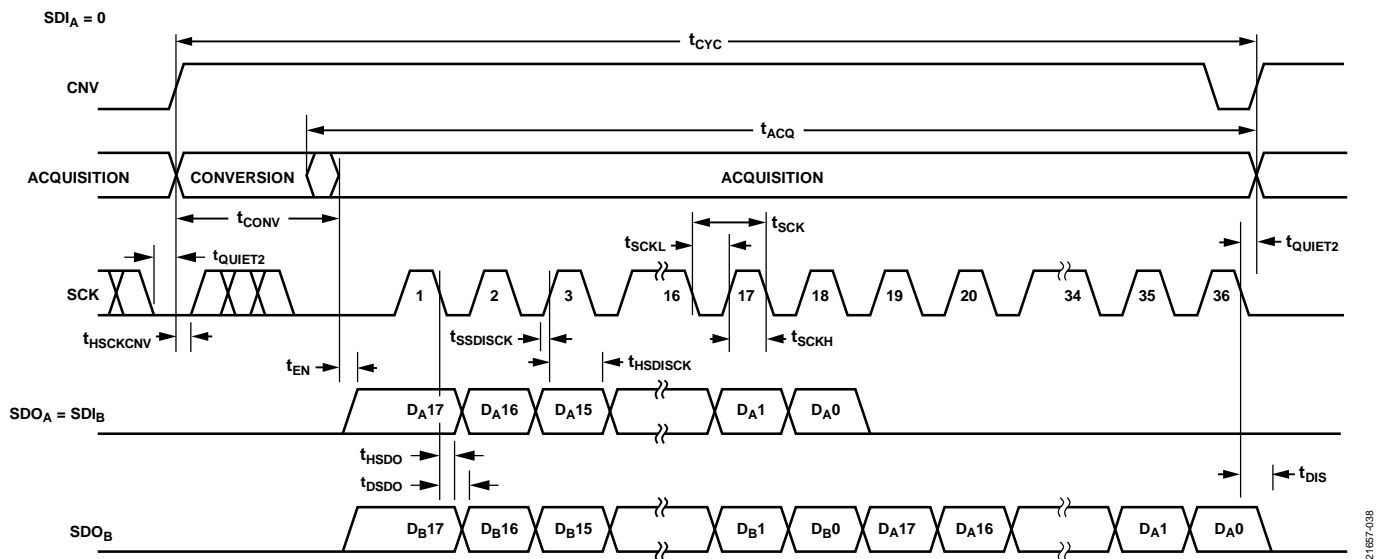

Figure 68. Daisy-Chain Mode Serial Interface Timing Diagram

LAYOUT GUIDELINES

The PCB layout is critical for preserving signal integrity and achieving the expected performance from the ADAQ4003. It is recommended to design a multilayer board with an internal, clean ground plane and a separate power plane to route various supply rails beneath the ADAQ4003. Care must be taken with the placement of individual components and routing of various signals on the board. It is highly recommended to route input and output signals symmetrically while keeping the power supply circuitry away from the analog signal path. Keep the sensitive analog and digital sections separate and confined to certain areas of the board and avoid crossover of digital and analog signals.

The pinout of the ADAQ4003 eases the layout and allowing its analog signals on the left side and its digital signals on the right side. Fast switching signals, such as CNV or clocks, must not run near or crossover analog signal paths to prevent noise coupling to the ADAQ4003. Remove the ground and power planes beneath the input and output pins of ADAQ4003 to avoid undesired parasitic capacitance, especially underneath summing junction nodes (IN+ and IN-) and any floating inputs. Any undesired parasitic capacitance on the summing junction nodes tends to reduce the phase margin of the FDA and impact the distortion and linearity performance of the ADAQ4003.

The ADAQ4003 enables high channel density PCB layout by incorporating all the necessary decoupling ceramic capacitors for the reference and power supply (REF, VS+, VS-, VDD, and VIO) pins to provide a low impedance path to ground at high frequencies and to handle the transient currents so that the additional external decoupling capacitors are not required without causing any performance impact or electromagnetic interference (EMI) issues, saving board space. This performance impact was verified on the [EVAL-ADAQ4003FMCZ](#) by removing the external decoupling capacitors on the output of reference and LDO regulators that generate the on-board rails (REF, VS+, VS-, VDD, and VIO). Figure 69 shows that any spurs are buried well below -120 dB in the noise floor whether the external decoupling capacitors are used or removed. The recommended board layout is outlined in the [EVAL-ADAQ4003FMCZ](#) user guide.

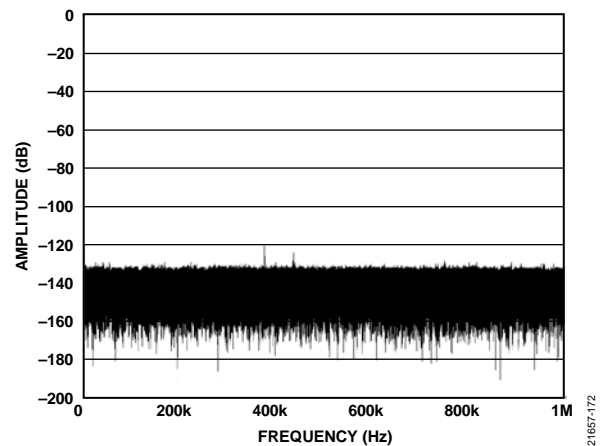

Figure 69. FFT with Shorted Inputs

OUTLINE DIMENSIONS

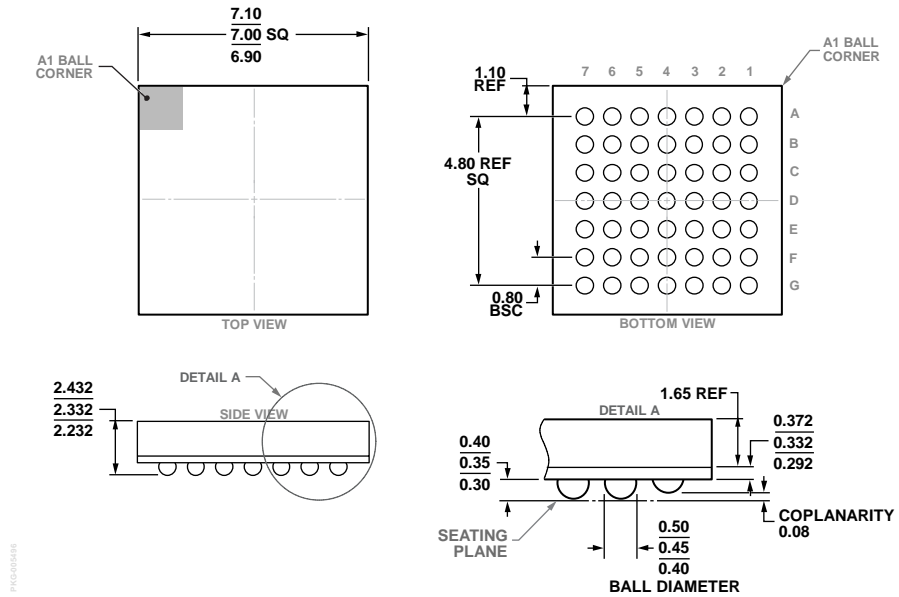

Figure 70. 49-Ball Chip Scale Package Ball Grid Array [CSP_BGA] (BC-49-5)
Dimensions shown in millimeters

ORDERING GUIDE

| Model ^{1, 2} | Temperature Range | Ordering Quantity | Package Description | Package Option |
|-----------------------|-------------------|-------------------|--|----------------|
| ADAQ4003BBCZ | -40°C to +125°C | Tray, 416 | 49-Ball Chip Scale Package Ball Grid Array [CSP_BGA] | BC-49-5 |
| ADAQ4003BBCZ-RL13 | -40°C to +125°C | Reel, 2000 | 49-Ball Chip Scale Package Ball Grid Array [CSP_BGA] | BC-49-5 |
| EVAL-ADAQ4003FMCZ | | | Evaluation Board Kit | |

¹ Z = RoHS Compliant Part.

² The [EVAL-ADAQ4003FMCZ](#) evaluation board kit is compatible with the [EVAL-SDP-CH1Z](#). See the [UG-1533](#) for more details.

Mouser Electronics

Authorized Distributor

Click to View Pricing, Inventory, Delivery & Lifecycle Information:

[Analog Devices Inc.:](#)

[ADAQ4003BBCZ](#) [ADAQ4003BBCZ-RL13](#) [EVAL-ADAQ4003FMCZ](#)