

Americas

Atlanta - 678-957-9614
Austin - 512-257-3370
Boston - 774-760-0087
Chicago - 630-285-0071
Dallas - 972-818-7423
Detroit - 248-848-4000
Houston - 281-894-5983
Indianapolis - 317-773-8323
Los Angeles - 949-462-9523
New York - 631-435-6000
Phoenix - 480-792-7200
Raleigh - 919-844-7510
San Jose - 408-735-9110
Toronto - 905-695-1980

Europe

Austria - Wels - 43-7242-2244-39
Denmark - Copenhagen - 45-4485-5910
Finland - Espoo - 358-9-4520-820
France - Paris - 33-1-69-53-63-20
Germany - Garching - 49-8931-9700
Germany - Haan - 49-2129-3766400
Germany - Heilbronn - 49-7131-72400
Germany - Karlsruhe - 49-721-625370
Germany - Munich - 49-89-627-144-0
Germany - Rosenheim - 49-8031-354-560
Israel - Ra'anana - 972-9-744-7705
Italy - Milan - 39-0331-742611
Italy - Padova - 39-049-7625286
Netherlands - Drunen - 31-416-690399
Norway - Trondheim - 47-7288-4388
Poland - Warsaw - 48-22-3325737
Romania - Bucharest - 40-21-407-87-50
Spain - Madrid - 34-91-708-08-90
Sweden - Gothenberg - 46-31-704-60-40
Sweden - Stockholm - 46-8-5090-4654
UK - Wokingham - 44-118-921-5800

Asia/Pacific

Australia - Sydney - 61-2-9868-6733
China - Beijing - 86-10-8569-7000
China - Chengdu - 86-28-8665-5511
China - Chongqing - 86-23-8980-9588
China - Dongguan - 86-769-8702-9880
China - Guangzhou - 86-20-8755-8029
China - Hangzhou - 86-571-8792-8115
China - Hong Kong SAR - 852-2943-5100
China - Nanjing - 86-25-8473-2460
China - Qingdao - 86-532-8502-7355
China - Shanghai - 86-21-3326-8000
China - Shenyang - 86-24-2334-2829
China - Shenzhen - 86-755-8864-2200
China - Suzhou - 86-186-6233-1526
China - Wuhan - 86-27-5980-5300
China - Xiamen - 86-592-2388138
China - Xian - 86-29-8833-7252
China - Zhuhai - 86-756-3210040
India - Bangalore - 91-80-3090-4444
India - New Delhi - 91-11-4160-8631
India - Pune - 91-20-4121-0141
Japan - Osaka - 81-6-6152-7160
Japan - Tokyo - 81-3-6880-3770
Korea - Daegu - 82-53-744-4301
Korea - Seoul - 82-2-554-7200
Malaysia - Kuala Lumpur - 60-3-7651-7906
Malaysia - Penang - 60-4-227-8870
Philippines - Manila - 63-2-634-9065
Singapore - 65-6334-8870
Taiwan - Hsin Chu - 886-3-577-8366
Taiwan - Kaohsiung - 886-7-213-7830
Taiwan - Taipei - 886-2-2508-8600
Thailand - Bangkok - 66-2-694-1351
Vietnam - Ho Chi Minh - 84-28-5448-2100

Overview

The PIC24F LCD and USB Curiosity Development Board (DM240018) is a demonstration, development and experimentation platform based on the PIC24FJ512GU410 low-power, low-cost microcontroller. The board has a built-in programmer/debugger and provides all the hardware necessary to get started developing a complete embedded application. Some key features of the board include:

- PIC24FJ512GU410 General Purpose USB, 16-Bit Microcontroller
- PICKIT™ On-Board (PKOB) Circuit implements Basic Programming/Debugging
 - CDC (UART over USB), supports 115.2k 8N1 only
- On-Board 5-Character LCD Panel with Backlight (8 common, 56 segments)
- MCLR Reset Button plus Two General Purpose Push Buttons
- Micro-B USB for developing PIC24FJ512GU410 USB Device Applications
- Red/Green/Blue (RGB) LED plus Two General Purpose Indicator LEDs
- Digital Temperature Sensor (TC77)
- 10k Potentiometer
- 32.768 kHz Secondary OSC for RTCC
- Female Headers for Access to Microcontroller I/O Pins
- Two mikroBUS™ Interfaces for Hardware Expansion
- Supports a Wide Variety of Add-On Click boards™ from MikroElektronika (www.mikroe.com)

Board Power-up

The board is intended to be powered through the Micro-B USB connector (J20 PKOB4) in the upper left side of the board. The J16 USB connector does not power the board, but is used for developing USB device applications with the PIC® MCU's USB peripheral. A MIC5528 linear regulator (U12) generates the +3.3V rail used by the PIC24FJ512GU410 microcontroller. The board can be powered by a CR2032 coin cell inserted into the B1 battery housing. The default jumper J9 setup is 2 and 3; this configuration can be left for power switching between USB and Battery Operation modes.

To measure the power consumption of the board, a meter can be placed between pins 2 and 3 of jumper J1 (that goes to the battery housing). To measure the current of the CPU, cut the trace on the bottom of the board under jumper J1 and place a meter between the two pins.

Note: The J16 USB connector does not power the board.

Getting Started

The preprogrammed “out-of-box” demo project for the PIC24F LCD and USB Curiosity Development Board has two main modes of operation, USB Powered and Battery-Powered.

USB Powered Mode:

In USB Powered mode, there are several different Display modes. Pressing the S2 button will cycle between each of the USB Display modes. The Display modes are listed below.

1. Toggles between the text, “PIC24” and “LCD”. Toggling is done automatically by the PIC MCU's LCD peripheral using the Alternate Display mode of the module.
2. Displays the 12-bit value of the potentiometer.
3. Displays the build time of the project. Note that this is the build time of the `build_time.c` file. A clean/build will update the time.
4. Displays the current temperature measured by the TC77 on the board. LCD Alternate Display mode toggles between Celsius and Fahrenheit.

Note: The backlight only operates while in USB mode.

2/28/20



Microchip Technology Inc. • 2355 West Chandler Blvd. • Chandler, AZ 85224-6199

www.microchip.com

The Microchip name and logo, the Microchip logo, and PIC are registered trademarks of Microchip Technology Incorporated in the U.S.A. and other countries. PICKIT is a trademark of Microchip Technology Incorporated in the U.S.A. and other countries. All other trademarks mentioned herein are property of their respective companies.
© 2020, Microchip Technology Incorporated, Printed in the U.S.A. All Rights Reserved. 7/20

DS50003009A

The potentiometer will change the intensity of the RGB LED channel that is currently active. Switch S1 will change which channel is currently active.

A COM port can be opened to view the data through the J16 USB connection. All of the above data are displayed on the screen (time, temperature, potentiometer, etc.). The PIC MCU's USB peripheral is acting as the UART-USB bridge.

Battery-Powered Mode:

If the USB power is disconnected, the board can run from a battery backup and will go into Battery-Powered mode. In order to run in Battery mode, a CR2032 needs to be inserted in the B1 battery housing and jumper J9 needs to short between pins 2 and 3.

In Battery-Powered mode, the moon icon is displayed. The battery status icon indicates the current battery status.

The time will be displayed on the screen. The “.” blinks using the LCD module's blink feature. The CPU does not need to wake up to update the screen for the “.”. The CPU wakes up once a minute in this mode to update the time on the screen. LED1 will blink while the CPU is awake. The CPU will also wake up when the USB power is detected.

All other functionality from the USB mode is disabled.

Note: The backlight only operates while in USB mode.

LCD Operation

Backlight operation is dependent on the USB 5V supply; the LCD backlight is disabled during Battery-Operated mode.

Pin assignment and LCD segment assignment are shown in [Figure 1](#).

FIGURE 1: MECHANICAL DRAWING AND SEGMENT ASSIGNMENT (DIMENSIONS IN mm)

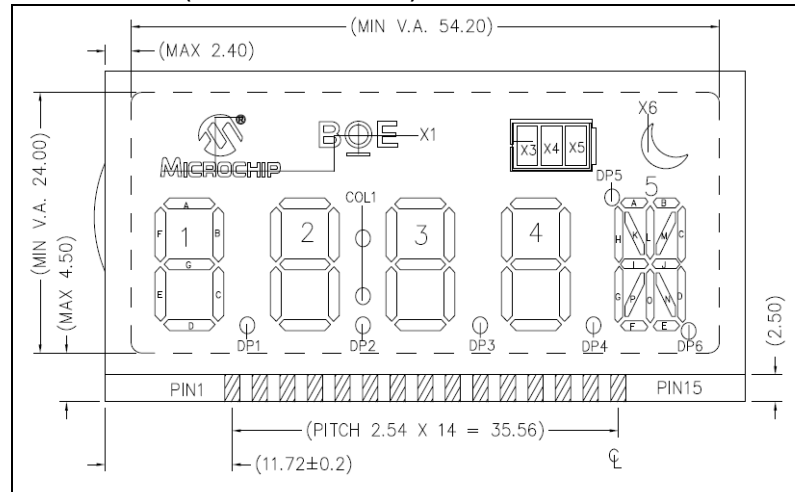

LCD panel pin and segment assignment are shown in [Figure 2](#).

FIGURE 2: LCD PANEL PIN AND SEGMENT ASSIGNMENT

PIN	COM1	COM2	COM3	COM4	COM5	COM6	COM7	COM8
1	COM1	---	---	---	---	---	---	---
2	---	COM2	---	---	---	---	---	---
3	---	---	COM3	---	---	---	---	---
4	---	---	---	COM4	---	---	---	---
5	---	---	---	---	COM5	---	---	---
6	---	---	---	---	---	COM6	---	---
7	---	---	---	---	---	---	COM7	---
8	---	---	---	---	---	---	---	COM8
9	1A	1F	1E	1D	2A	2F	2E	2D
10	1B	1G	1C	DP1	2B	2G	2C	DP2
11	4A	4F	4E	DP3	3A	3F	3E	COL1
12	4B	4G	4C	4D	3B	3G	3C	3D
13	X4	X1	DP5	5H	5G	5P	5F	DP4
14	X5	5A	5K	5L	5I	5O	5N	5E
15	X3	X6	5B	5M	5C	5J	5D	DP6

Schematics

The schematics for the PIC24F LCD and USB Curiosity Development Board are shown in [Figure 3](#) (microcontroller), [Figure 4](#) (I/O access), [Figure 5](#) (programmer/debugger) and [Figure 6](#) (on-board buffers).

FIGURE 3: PIC24 LCD AND USB CURIOSITY DEVELOPMENT BOARD SCHEMATIC

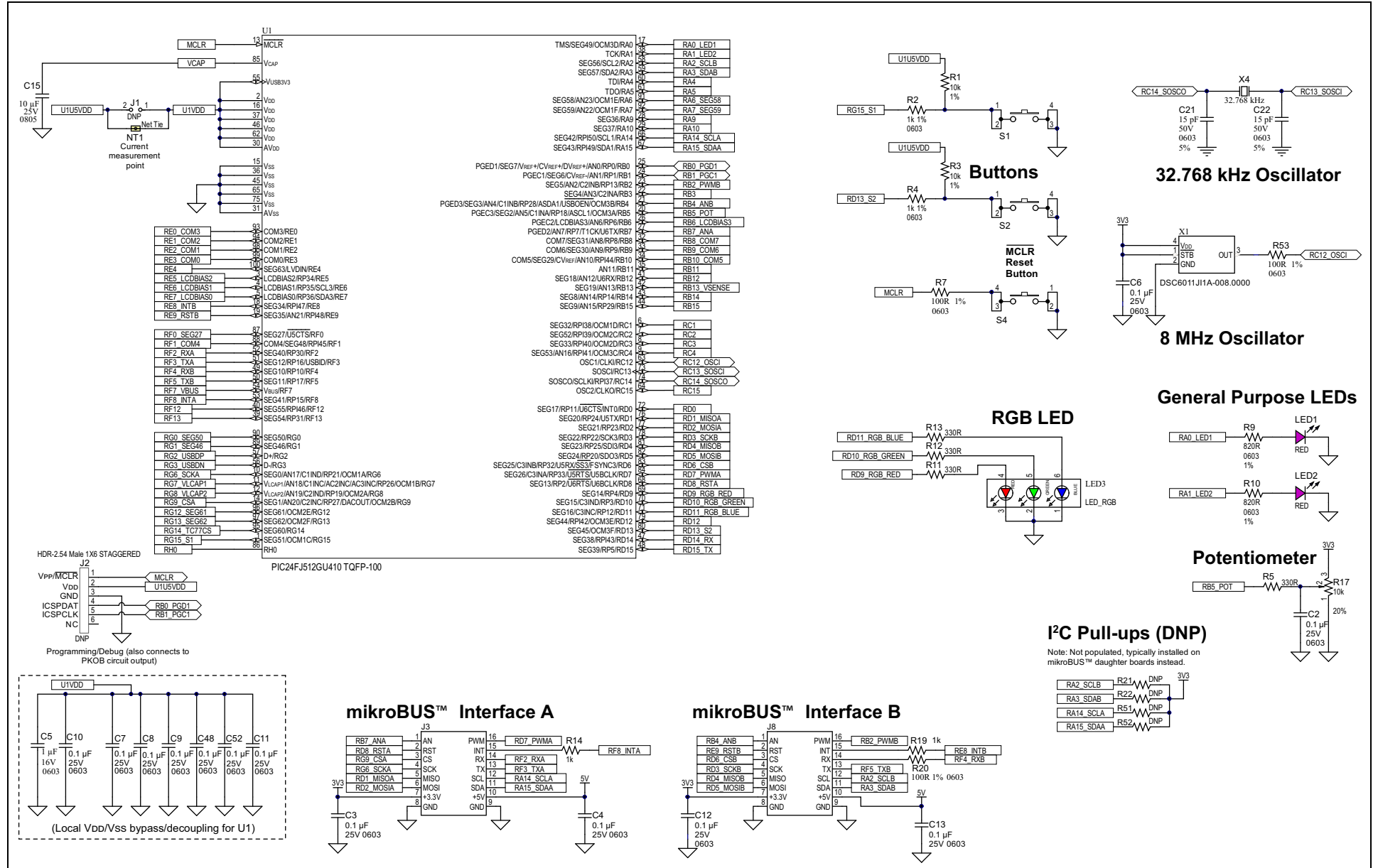

FIGURE 4: I/O ACCESS SCHEMATIC

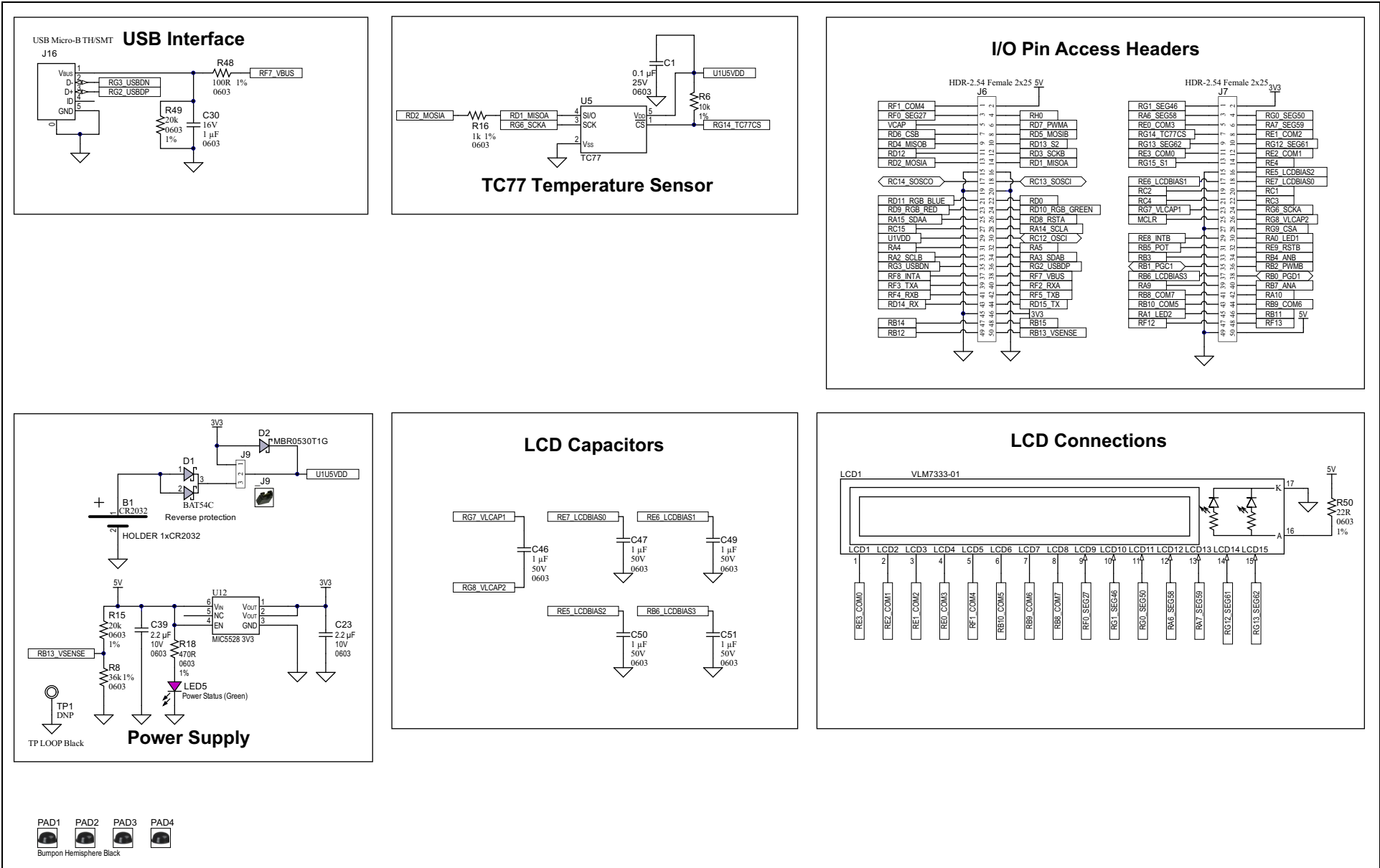

FIGURE 5: PROGRAMMER/DEBUGGER SCHEMATIC

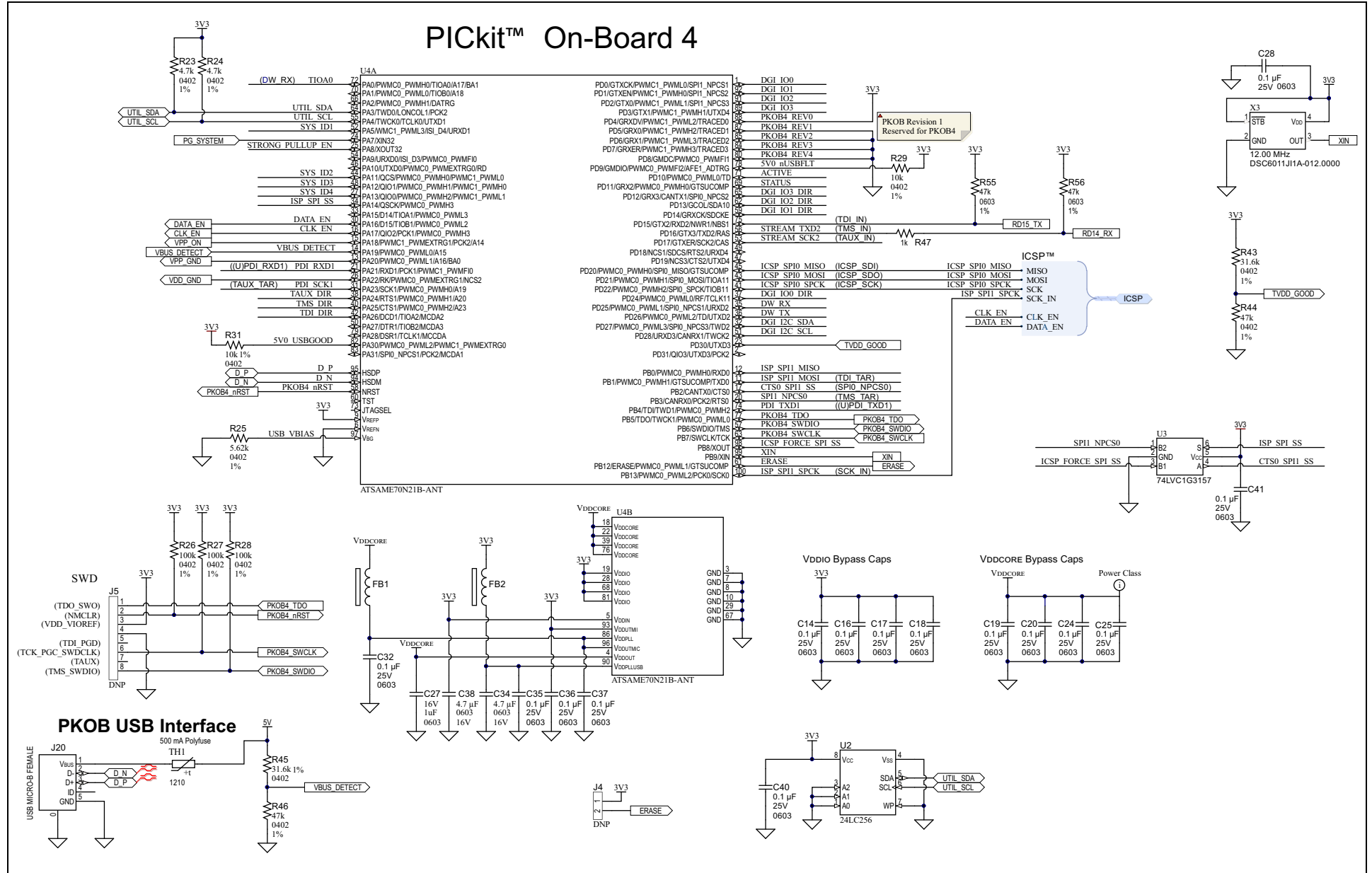
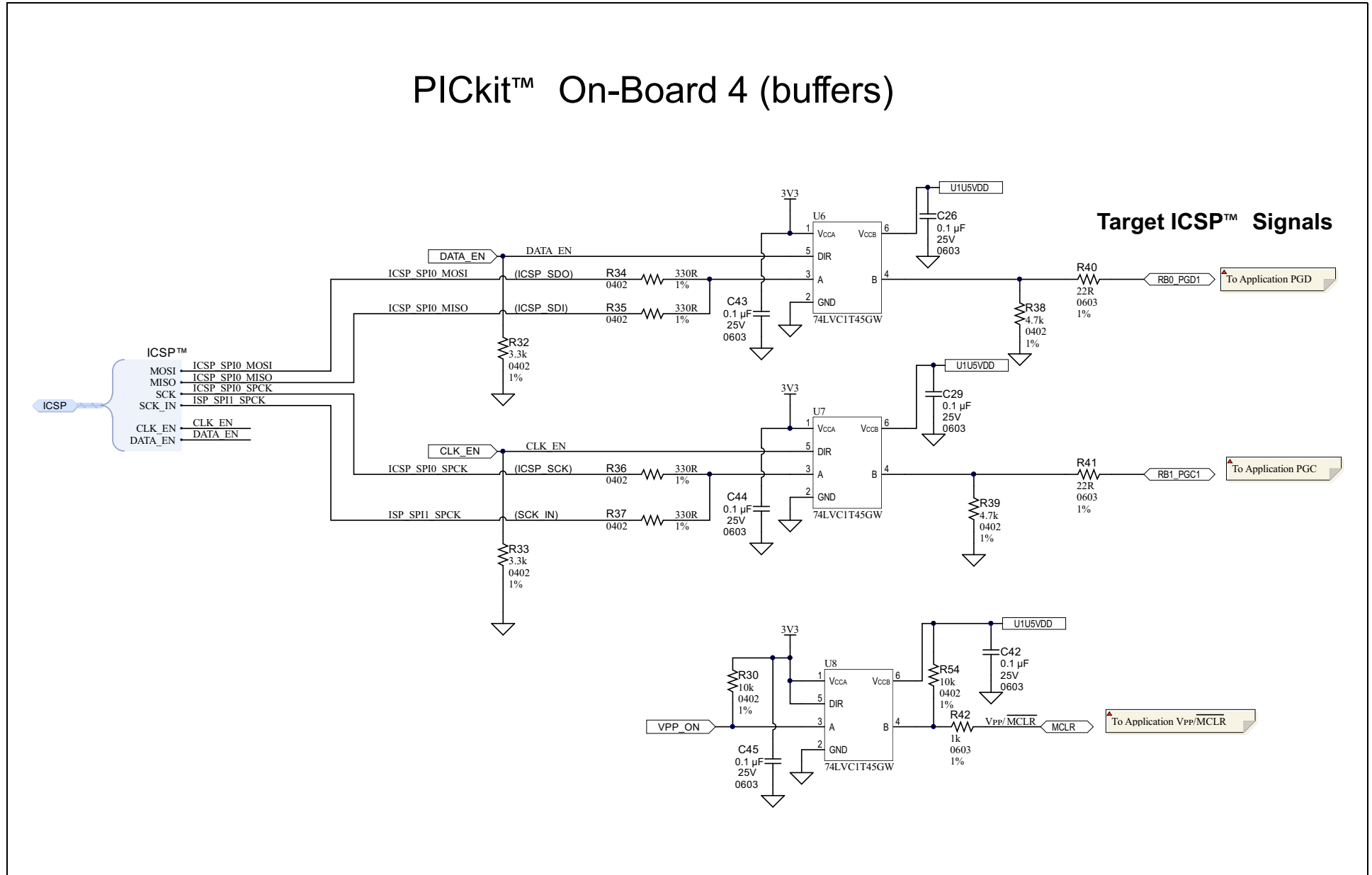

FIGURE 6: PICKIT ON-BOARD BUFFERS SCHEMATIC



Mouser Electronics

Authorized Distributor

Click to View Pricing, Inventory, Delivery & Lifecycle Information:

[Microchip:](#)

[DM240018](#)