

## DESCRIPTION

Demonstration Circuit 1482 is a fully integrated LED driver with 750mA switch current featuring the LT<sup>®</sup>3519. The board is optimized to drive a 100mA LED string between the input voltage and 38V in a boost topology. The high input voltage range, high-efficiency low-side integrated 45V 750mA power switch and catch diode, integrated compensation, low voltage floating current sense amplifier, high pwm dimming ratio, overvoltage protection, shutdown control pin, analog LED current dimming control, and fixed 400kHz switching frequency make the LT3519 an extremely versatile and powerful LED driving IC.

DC1482 has overvoltage protection at just above 40V if the LEDs are open or not properly attached to the terminals on the PCB. The shutdown function is activated by pulling the shutdown terminal to ground. Shutdown turns off the IC, but still allows the input voltage to be seen at the output. The LEDs can leak small current if VIN is high enough to turn them on during shutdown. The CTRL terminal can be used to analog dim the LED current. The CTRL terminal is pulled up with a resistor divider between VIN and GND. As VIN drops too low,

CTRL voltage drops and the LED current is scaled back.

The VIN pin is tied directly to PVIN through a zero ohm resistor. The VIN pin and terminal can be separated from PVIN for some applications such as buck mode by removing this zero ohm resistor. A few simple modifications can be made to DC1482 in order to convert the board from a boost LED driver to a SEPIC, buck mode, or buck-boost mode LED driver. Please consult the datasheet for schematic details and the factory for customization details.

The LT3519 datasheet gives a complete description of the part, operation and applications information. The datasheet must be read in conjunction with this Quick Start Guide for demonstration circuit 1482. The LT3519 is assembled in a small 16-lead plastic MSOP package. Proper board layout is essential for maximum thermal performance. See the datasheet section 'Layout Considerations'.

**Design files for this circuit board are available. Call the LTC factory.**

LT is a trademark of Linear Technology Corporation

## QUICK START PROCEDURE

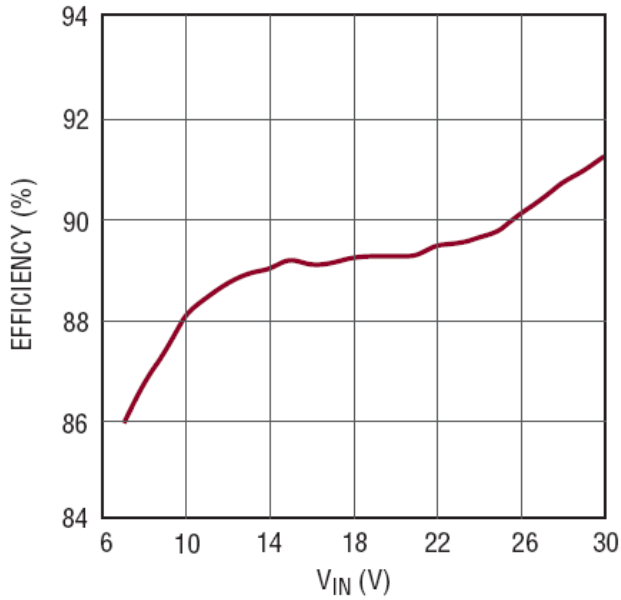
DC1482 is easy to set up to evaluate the performance of the LT3519. Follow the procedure below:

**NOTE:** Make sure that the input voltage does not exceed 40V at all times and 30V DC.

1. Connect a string of LEDs with forward voltage less than 38V, but greater than the input voltage, to the LED+ and LED- terminals on the PCB as shown.
2. With power off, connect a 6V-30V input power supply to the VIN (or PVIN) and GND terminals on the PCB. Make sure that VIN does not exceed the voltage of the LED string.
3. Connect a 3.3V source to PWM and GND.
4. Turn the input power on and observe the regulated LED current, the circuit efficiency, etc. without looking directly at the LEDs.
5. For PWM dimming, tie a 100Hz (or higher), 3-5V PWM waveform to the PWM terminal and GND and observe the PWM dimming LED current and PWM gate waveforms.

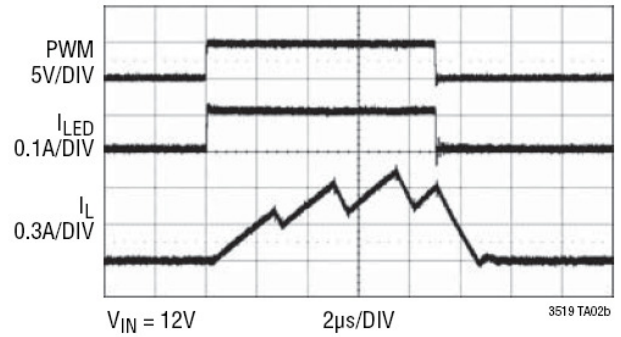
- For shutdown, tie the SHDN/UVLO terminal to GND and observe the IC turning off.

**Efficiency vs  $V_{IN}$**

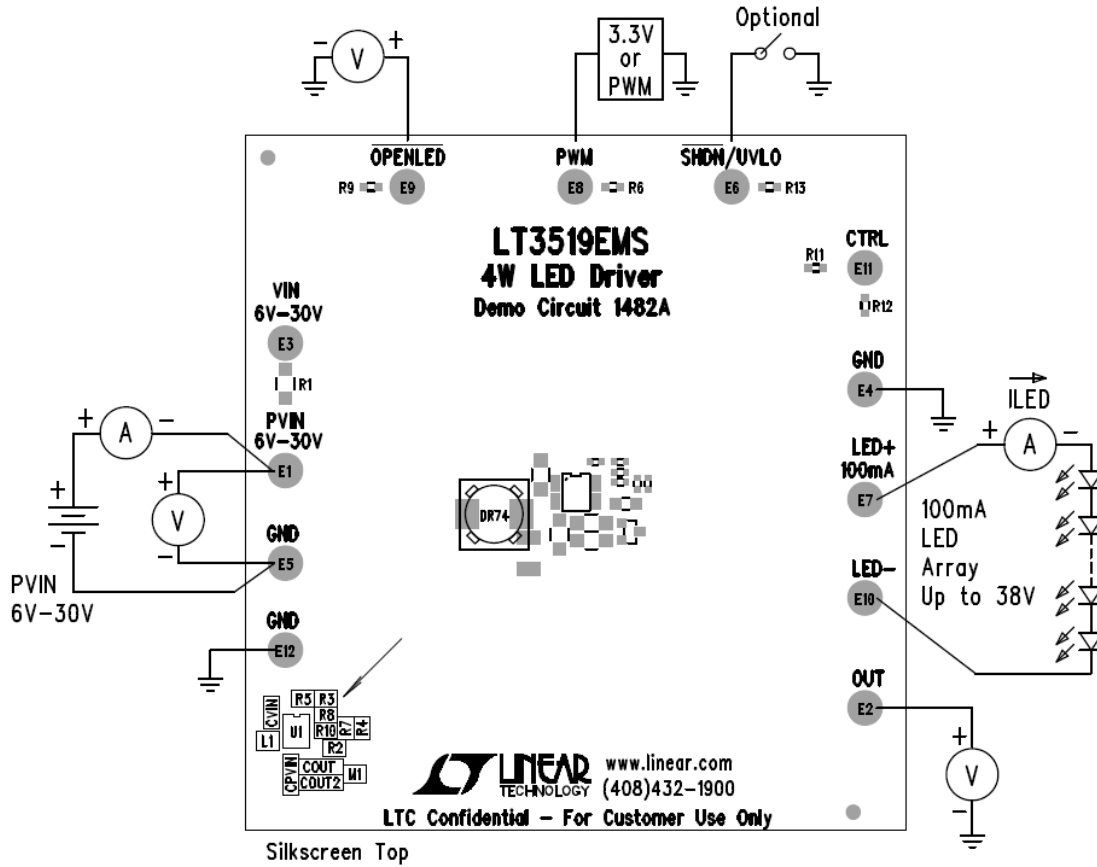


**Figure 1. DC1482 Efficiency vs.  $V_{IN}$  38VLED at 100mA**

**1000:1 PWM Dimming at 120Hz**

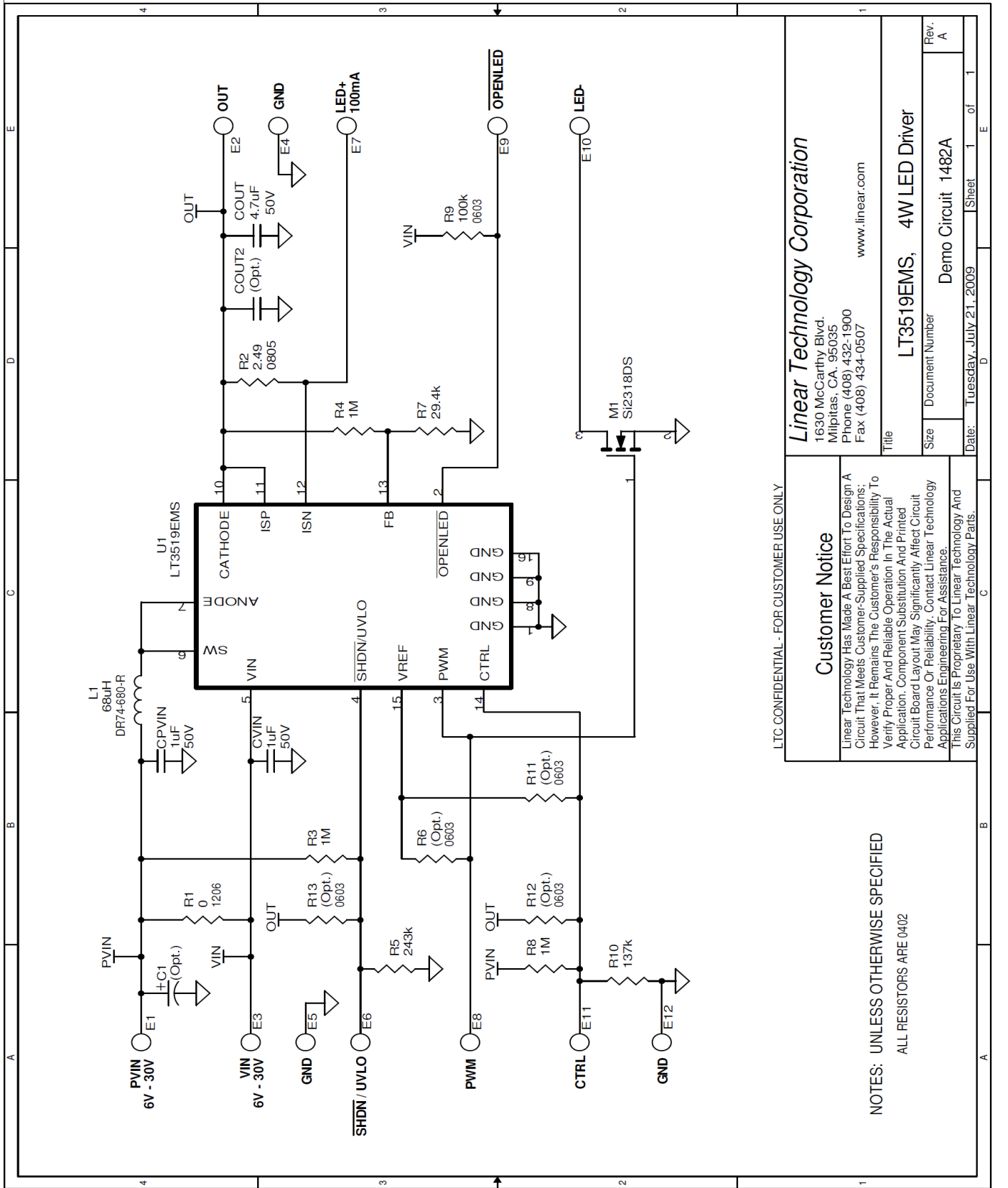


**Figure 2. DC1482A 38V LED string PWM Dim,  $V_{IN}=12V$**



Silkscreen Top

Figure 3. Proper Measurement Equipment Setup



LTC CONFIDENTIAL - FOR CUSTOMER USE ONLY

# Mouser Electronics

Authorized Distributor

Click to View Pricing, Inventory, Delivery & Lifecycle Information:

[Analog Devices Inc.:](#)

[DC1482A](#)