**32-Mbit, 1.7V Minimum
SPI Serial Flash Memory with Dual I/O, Quad I/O and QPI Support**

Features

- Single 1.7V - 2.0V Supply
- Serial Peripheral Interface (SPI) and Quad Peripheral Interface (QPI) Compatible
 - Supports SPI Modes 0 and 3
 - Supports Dual Output Read and Quad I/O Program and Read
 - Supports QPI Program and Read
 - 104 MHz* Maximum Operating Frequency
 - Clock-to-Output (t_{V1}) of 6 ns
 - Up to 65MB/S continuous data transfer rate
- Full Chip Erase
- Flexible, Optimized Erase Architecture for Code and Data Storage Applications
 - 0.6 ms Typical Page Program (256 Bytes) Time
 - 60 ms Typical 4-Kbyte Block Erase Time
 - 200 ms Typical 32-Kbyte Block Erase Time
 - 300 ms Typical 64-Kbyte Block Erase Time
- Hardware Controlled Locking of Protected Blocks via \overline{WP} Pin
- 4K-bit secured One-Time Programmable Security Register
- Hardware Write Protection
- Serial Flash Discoverable Parameters (SFDP) Register
- Flexible Programming
 - Byte/Page Program (1 to 256 Bytes)
 - Dual or Quad Input Byte/Page Program (1 to 256 Bytes)
 - Accelerated programming mode via 9V ACC pin
- Erase/Program Suspend and Resume
- JEDEC Standard Manufacturer and Device ID Read Methodology
- Low Power Dissipation
 - 2 μ A Deep Power-Down Current (Typical)
 - 10 μ A Standby current (Typical)
 - 5mA Active Read Current (Typical)
- Endurance: 100,000 program/erase cycles (4KB, 32KB or 64KB blocks)
- Data Retention: 20 Years
- Industrial Temperature Range: -40°C to +85°C
- Industry Standard Green (Pb/Halide-free/RoHS Compliant) Package Options
 - 8-lead SOIC (208-mil)
 - 8-pad DFN (6 x 5 x 0.6 mm)
 - 24-ball Ball Grid Array (BGA)
 - 8 and 10-ball WLCSP, die Ball Grid Array (dBGA)
 - 8-pad USON(3 x 4 x 0.55mm)
 - Die in Wafer Form

1. Introduction

The Adesto® AT25SL321 is a serial interface Flash memory device designed for use in a wide variety of high-volume consumer based applications in which program code is shadowed from Flash memory into embedded or external RAM for execution. The flexible erase architecture of the AT25SL321 is ideal for data storage as well, eliminating the need for additional data storage devices.

The erase block sizes of the AT25SL321 have been optimized to meet the needs of today's code and data storage applications. By optimizing the size of the erase blocks, the memory space can be used much more efficiently. Because certain code modules and data storage segments must reside by themselves in their own erase regions, the wasted and unused memory space that occurs with large block erase Flash memory devices can be greatly reduced. This increased memory space efficiency allows additional code routines and data storage segments to be added while still maintaining the same overall device density.

SPI clock frequencies of up to 104MHz* are supported allowing equivalent clock rates of 266MHz for Dual Output and 532MHz for Quad Output when using the QPI and Fast Read Dual/Quad I/O instructions. The AT25SL321 array is organized into 65,536 programmable pages of 256-bytes each. Up to 256 bytes can be programmed at a time using the Page Program instructions. Pages can be erased 4KB Block, 32KB Block, 64KB Block or the entire chip.

The devices operate on a single 1.7V to 1.95V power supply with current consumption as low as 5mA active and 2µA for Deep Power Down. All devices offered in space-saving packages. The device supports JEDEC standard manufacturer and device identification with a 4K-bit Secured OTP.

*Contact Adesto for availability of 133MHz operating frequency.

2. Pinouts and Pin Descriptions

The following figures show the available package types.

Figure 1-1. 8-SOIC (Top View)

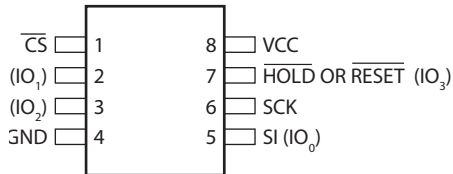

Figure 1-2. 8-UDFN (Top View)

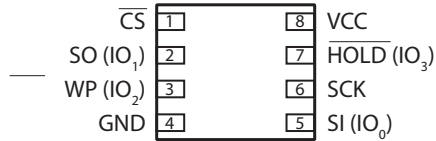

Figure 1-3. 24-dBGA (Top View)

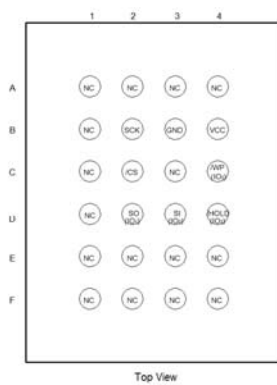

Figure 1-4. 8-WLCSP (Bottom View)

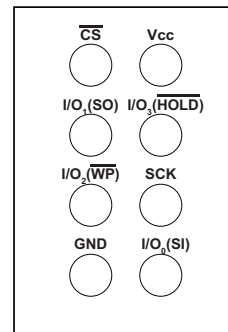

Figure 1-5. 10-WLCSP (Bottom View)

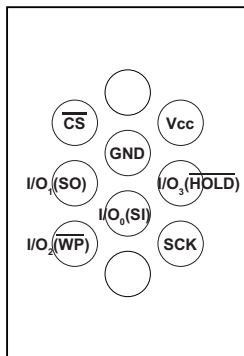
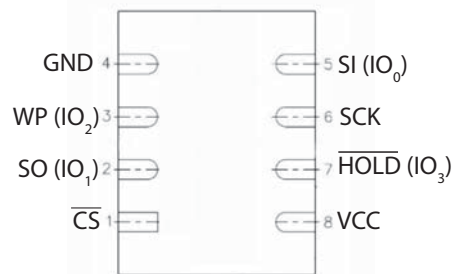

Figure 1-6. 8-pad USON (Bottom View)



*Final package outline drawing to be confirmed.

During all operations, V_{CC} must be held stable and within the specified valid range: V_{CC} (min) to V_{CC} (max).
 All of the input and output signals must be held high or low (according to voltages of VIH, VOH, VIL or VOL).

Table 1-1. Pin Descriptions

| Symbol | Name and Function | Asserted State | Type |
|------------------------|---|----------------|--------------|
| \overline{CS} | <p>CHIP SELECT</p> <p>When this input signal is high, the device is deselected and serial data output pins are at high impedance. Unless an internal program, erase or write status register cycle is in progress, the device will be in the standby power mode (this is not the deep power down mode). Driving Chip Select (\overline{CS}) low enables the device, placing it in the active power mode. After power-up, a falling edge on Chip Select (\overline{CS}) is required prior to the start of any instruction.</p> | Low | Input |
| SCK | <p>SERIAL CLOCK</p> <p>This input signal provides the timing for the serial interface. Instructions, addresses, or data present at serial data input are latched on the rising edge of Serial Clock (SCK). Data are shifted out on the falling edge of the Serial Clock (SCK).</p> | - | Input |
| SI (I/O ₀) | <p>SERIAL INPUT</p> <p>The SI pin is used to shift data into the device. The SI pin is used for all data input including command and address sequences. Data on the SI pin is always latched in on the rising edge of SCK.</p> <p>With the Dual-Output and Quad-Output Read commands, the SI Pin becomes an output pin (I/O₀) in conjunction with other pins to allow two or four bits of data on (I/O₃₋₀) to be clocked in on every falling edge of SCK</p> <p>To maintain consistency with the SPI nomenclature, the SI (I/O₀) pin is referenced as the SI pin unless specifically addressing the Dual-I/O and Quad-I/O modes in which case it is referenced as I/O₀.</p> <p>Data present on the SI pin is ignored whenever the device is deselected (\overline{CS} is deasserted).</p> | - | Input/Output |
| SO (I/O ₁) | <p>SERIAL OUTPUT</p> <p>The SO pin is used to shift data out from the device. Data on the SO pin is always clocked out on the falling edge of SCK.</p> <p>With the Dual-Output Read commands, the SO Pin remains an output pin (I/O₀) in conjunction with other pins to allow two bits of data on (I/O₁₋₀) to be clocked in on every falling edge of SCK</p> <p>To maintain consistency with the SPI nomenclature, the SO (I/O₁) pin is referenced as the SO pin unless specifically addressing the Dual-I/O modes in which case it is referenced as I/O₁. The SO pin is in a high-impedance state whenever the device is deselected (\overline{CS} is deasserted).</p> | - | Input/Output |

Table 1-1. Pin Descriptions (Continued)

| Symbol | Name and Function | Asserted State | Type |
|---------------------------------------|--|----------------|--------------|
| \overline{WP} (I/O ₂) | <p>WRITE PROTECT</p> <p>The Write Protect (\overline{WP}) pin can be used to protect the Status Register against data modification. The \overline{WP} pin is active low. When the QE bit of Status Register-2 is set for Quad I/O, the \overline{WP} pin (Hardware Write Protect) function is not available since this pin is used for IO₂. See figures 1-1, 1-2, and 1-3 for the pin configuration of Quad I/O and QPI operation.</p> | - | Input/Output |
| ACC | <p>ACCELERATED PROGRAMMING</p> <p>The device offers accelerated program operations through the ACC function. This function is primarily intended to allow faster manufacturing throughput at the factory. If the system asserts V_{HH} on this pin, the device uses the higher voltage on the pin to reduce the time required for program operations. Removing V_{HH} from the ACC pin returns the device to normal operation.</p> <p>Note that the ACC pin must not be at V_{HH} for operations other than accelerated programming, or device damage may result. In addition, the ACC pin must not be left floating or unconnected; inconsistent behavior of the device may result. The ACC function is only available during standard SPI Mode.</p> | | |
| \overline{HOLD} (I/O ₃) | <p>HOLD</p> <p>The \overline{HOLD} pin is used to pause a serial sequence of the SPI flash memory without resetting the clocking sequence. To enable the \overline{HOLD} mode, the \overline{CS} must be in low state. The \overline{HOLD} mode effects on with the falling edge of the \overline{HOLD} signal with CLK being low. The \overline{HOLD} mode ends on the rising edge of \overline{HOLD} signal with SCK being low.</p> <p>In other words, \overline{HOLD} mode can't be entered unless SCK is low at the falling edge of the \overline{HOLD} signal. And \overline{HOLD} mode can't be exited unless SCK is low at the rising edge of the \overline{HOLD} signal.</p> <p>If \overline{CS} is driven high during a \overline{HOLD} condition, it resets the internal logic of the device. As long as \overline{HOLD} signal is low, the memory remains in the \overline{HOLD} condition. To re-work communication with the device, \overline{HOLD} must go high, and \overline{CS} must go low. See Figure 8.11 for \overline{HOLD} timing.</p> | - | Input/Output |
| V_{CC} | <p>DEVICE POWER SUPPLY: V_{CC} is the supply voltage. It is the single voltage used for all device functions including read, program, and erase. The V_{CC} pin is used to supply the source voltage to the device. Operations at invalid V_{CC} voltages may produce spurious results and should not be attempted.</p> | - | Power |
| GND | <p>GROUND: V_{SS} is the reference for the V_{CC} supply voltage. The ground reference for the power supply. GND should be connected to the system ground.</p> | - | Power |

2. Block Diagram

Figure 2-1 shows a block diagram of the AT25SL321 serial Flash.

Figure 2-1. AT25SL321 Block Diagram

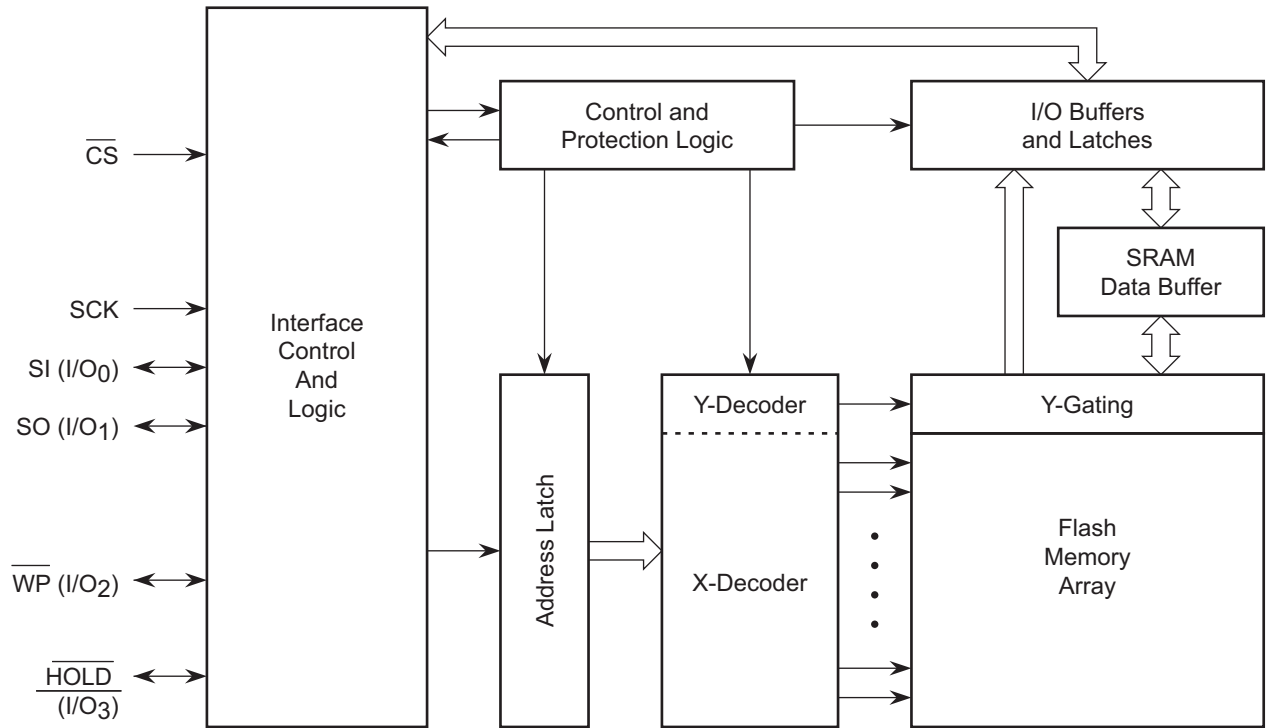

Note: I/O₃₋₀ pin naming convention is used for Dual-I/O and Quad-I/O commands.

3. Memory Array

To provide the greatest flexibility, the memory array of the AT25SL321 can be erased in four levels of granularity including a full chip erase. The size of the erase blocks is optimized for both code and data storage applications, allowing both code and data segments to reside in their own erase regions. The Memory Architecture Diagram illustrates the breakdown of each erase level.

Figure 3-1. Memory Architecture Diagram

| Block Erase Detail | | | | Page Program Detail | |
|--------------------|-----------|-----|---------------------|---------------------|--------------------|
| 64KB | 32KB | 4KB | Block Address Range | 1-256 Byte | Page Address Range |
| Sector 63 | Block 127 | 4KB | 3FFFFFh – 3FF000h | 256 Bytes | 3FFFFFh – 3FFF00h |
| | | 4KB | 3FEFFFh – 3FE000h | 256 Bytes | 3FFEFFh – 3FFE00h |
| | | 4KB | 3FDFFFh – 3FD000h | 256 Bytes | 3FFDFFh – 3FFD00h |
| | | 4KB | 3FCFFFh – 3FC000h | 256 Bytes | 3FFCFFh – 3FFC00h |
| | | 4KB | 3FBFFFh – 3FB000h | 256 Bytes | 3FFBFFh – 3FFB00h |
| | | 4KB | 3FAFFFh – 3FA000h | 256 Bytes | 3FFAFFh – 3FFA00h |
| | | 4KB | 3F9FFFh – 3F9000h | 256 Bytes | 3FF9FFh – 3FF900h |
| | | 4KB | 3F8FFFh – 3F8000h | 256 Bytes | 3FF8FFh – 3FF800h |
| | | 4KB | 3F7FFFh – 3F7000h | 256 Bytes | 3FF7FFh – 3FF700h |
| | | 4KB | 3F6FFFh – 3F6000h | 256 Bytes | 3FF6FFh – 3FF600h |
| | | 4KB | 3F5FFFh – 3F5000h | 256 Bytes | 3FF5FFh – 3FF500h |
| | | 4KB | 3F4FFFh – 3F4000h | 256 Bytes | 3FF4FFh – 3FF400h |
| | Block 126 | 4KB | 3F3FFFh – 3F3000h | 256 Bytes | 3FF3FFh – 3FF300h |
| | | 4KB | 3F2FFFh – 3F2000h | 256 Bytes | 3FF2FFh – 3FF200h |
| | | 4KB | 3F1FFFh – 3F1000h | 256 Bytes | 3FF1FFh – 3FF100h |
| | | 4KB | 3F0FFFh – 3F0000h | 256 Bytes | 3FF0FFh – 3FF000h |
| | | 4KB | 3EFFFFh – 3EF000h | 256 Bytes | 3FEFFFh – 3FEF00h |
| | | 4KB | 3EFFFFh – 3EE000h | 256 Bytes | 3FEFFFh – 3FEE00h |
| | | 4KB | 3EDFFFh – 3ED000h | 256 Bytes | 3FEDFFh – 3FED00h |
| | | 4KB | 3ECFFFh – 3EC000h | 256 Bytes | 3FECFFh – 3FEC00h |
| | | 4KB | 3EBFFFh – 3EB000h | 256 Bytes | 3FEBFFh – 3FEB00h |
| | | 4KB | 3EAFh – 3EA000h | 256 Bytes | 3FEAFh – 3FEA00h |
| | | 4KB | 3E9FFFh – 3E9000h | 256 Bytes | 3FE9FFh – 3FE900h |
| | | 4KB | 3E8FFFh – 3E8000h | 256 Bytes | 3FE8FFh – 3FE800h |
| Sector 62 | Block 125 | 4KB | 3E7FFFh – 3E7000h | : | : |
| | | 4KB | 3E6FFFh – 3E6000h | : | : |
| | | 4KB | 3E5FFFh – 3E5000h | : | : |
| | | 4KB | 3E4FFFh – 3E4000h | : | : |
| | | 4KB | 3E3FFFh – 3E3000h | : | : |
| | | 4KB | 3E2FFFh – 3E2000h | : | : |
| | Block 124 | 4KB | 3E1FFFh – 3E1000h | : | : |
| | | 4KB | 3E0FFFh – 3E0000h | : | : |
| | | 4KB | 00FFFFh – 00F000h | 256 Bytes | 0017FFh – 001700h |
| | | 4KB | 00EFFFh – 00E000h | 256 Bytes | 0016FFh – 001600h |
| | | 4KB | 00DFFFh – 00D000h | 256 Bytes | 0015FFh – 001500h |
| | | 4KB | 00CFFFh – 00C000h | 256 Bytes | 0014FFh – 001400h |
| Sector 0 | Block 1 | 4KB | 00BFFFh – 00B000h | 256 Bytes | 0013FFh – 001300h |
| | | 4KB | 00AFFFh – 00A000h | 256 Bytes | 0013FFh – 001300h |
| | | 4KB | 009FFFh – 009000h | 256 Bytes | 0012FFh – 001200h |
| | | 4KB | 008FFFh – 008000h | 256 Bytes | 0011FFh – 001100h |
| | | 4KB | 007FFFh – 007000h | 256 Bytes | 0010FFh – 001000h |
| | | 4KB | 006FFFh – 006000h | 256 Bytes | 000FFFh – 000F00h |
| | | 4KB | 005FFFh – 005000h | 256 Bytes | 000CFFh – 000C00h |
| | | 4KB | 004FFFh – 004000h | 256 Bytes | 000BFFh – 000B00h |
| | | 4KB | 003FFFh – 003000h | 256 Bytes | 000AFFh – 000A00h |
| | | 4KB | 002FFFh – 002000h | 256 Bytes | 0009FFh – 000900h |
| | | 4KB | 001FFFh – 001000h | 256 Bytes | 0008FFh – 000800h |
| | | 4KB | 000FFFh – 000000h | 256 Bytes | 0007FFh – 000700h |
| | Block 0 | 4KB | 000FFFh – 000000h | 256 Bytes | 0006FFh – 000600h |
| | | 4KB | 000FFFh – 000000h | 256 Bytes | 0005FFh – 000500h |
| | | 4KB | 000FFFh – 000000h | 256 Bytes | 0004FFh – 000400h |
| | | 4KB | 000FFFh – 000000h | 256 Bytes | 0003FFh – 000300h |
| | | 4KB | 000FFFh – 000000h | 256 Bytes | 0002FFh – 000200h |
| | | 4KB | 000FFFh – 000000h | 256 Bytes | 0001FFh – 000100h |
| | | 4KB | 000FFFh – 000000h | 256 Bytes | 0000FFh – 000000h |

4. Device Operation

4.1 Standard SPI Operation

The AT25SL321 features a serial peripheral interface on four signals: Serial Clock (SCK), Chip Select (\overline{CS}), Serial Data Input (SI) and Serial Data Output (SO). Standard SPI instructions use the SI input pin to serially write instructions, addresses or data to the device on the rising edge of SCK. The SO output pin is used to read data or status from the device on the falling edge of SCK.

SPI bus operation Modes 0 (0, 0) and 3 (1, 1) are supported. The primary difference between Mode 0 and Mode 3 concerns the normal state of the SCK signal when the SPI bus master is in standby and data is not being transferred to the Serial Flash. For Mode 0 the SCK signal is normally low on the falling and rising edges of \overline{CS} . For Mode 3 the SCK signal is normally high on the falling and rising edges of \overline{CS} .

4.2 Dual SPI Operation

The AT25SL321 supports Dual SPI operation. This instruction allows data to be transferred to or from the device at two times the rate of the standard SPI. The Dual Read instruction is ideal for quickly downloading code to RAM upon power-up (code-shadowing) or for executing non-speed-critical code directly from the SPI bus (XIP). When using Dual SPI instructions the SI and SO pins become bidirectional I/O pins; IO₀ and IO₁.

4.3 Quad SPI Operation

The AT25SL321 supports Quad SPI operation. This instruction allows data to be transferred to or from the device at four times the rate of the standard SPI. The Quad Read instruction offers a significant improvement in continuous and random access transfer rates allowing fast code-shadowing to RAM or execution directly from the SPI bus (XIP). When using Quad SPI instruction the SI and SO pins become bidirectional IO₀ and IO₁, and the \overline{WP} and \overline{HOLD} pins become IO₂ and IO₃ respectively. Quad SPI instructions require the non-volatile Quad Enable bit (QE) in Status Register-2 to be set.

4.4 QPI Operation

The AT25SL321 supports Quad Peripheral Interface (QPI) operation when the device is switched from Standard/ Dual/ Quad SPI mode to QPI mode using the “Enable QPI (38h)” instruction. To enable QPI mode, the non-volatile Quad Enable bit (QE) in Status Register-2 is required to be set. When using QPI instructions, the SI and SO pins become bidirectional IO₀ and IO₁, and the \overline{WP} and \overline{HOLD} pins become IO₂ and IO₃ respectively.

The typical SPI protocol requires that the byte-long instruction code being shifted into the device only via SI pin in eight serial clocks. The QPI mode utilizes all four IO pins to input the instruction code, thus only two serial clocks are required. This can significantly reduce the SPI instruction overhead and improve system performance in an XIP environment. Standard/ Dual/ Quad SPI mode and QPI mode are exclusive. Only one mode can be active at any given time, “Enable QPI” and “Disable QPI/ Disable QPI 2” instructions are used to switch between these two modes. Upon power-up or after software reset using “Reset (99h)” instruction, the default state of the device is Standard/ Dual/ Quad SPI mode.

5. Write Protection

To protect inadvertent writes by the possible noise, several means of protection are applied to the Flash memory.

5.1 Write Protect Features

- While Power-on reset, all operations are disabled and no instruction is recognized.
- An internal time delay of tPUW can protect the data against inadvertent changes while the power supply is outside the operating specification. This includes the Write Enable, Page program, Block Erase, Chip Erase, Write Security Register and the Write Status Register instructions.
- For data changes, Write Enable instruction must be issued to set the Write Enable Latch (WEL) bit to “0”. Power-up, Completion of Write Disable, Write Status Register, Page program, Block Erase and Chip Erase are subjected to this condition.
- Write Protect (\overline{WP}) pin can control to change the Status Register under hardware control.
- The Deep Power Down mode provides extra protection from unexpected data changes as all instructions are ignored under this status except for Release Deep Power Down instruction.

6. Status Register

The Read Status Register instruction can be used to provide status on the availability of the Flash memory array, if the device is write enabled or disabled the state of write protection and the Quad SPI setting. The Write Status Register instruction can be used to configure the devices writes protection features and Quad SPI setting. Write access to the Status Register is controlled by in some cases of the WP pin.

Table 6-1. Status Register-1

| S7 | S6 | S5 | S4 | S3 | S2 | S1 | S0 |
|--|----------|----------|----------|----------|----------|--------------------|----------------------------|
| SRP | (R) | (R) | (R) | (R) | (R) | WEL | BUSY |
| Status Register Protect 0 (Non-Volatile) | Reserved | Reserved | Reserved | Reserved | Reserved | Write Enable Latch | Erase or Write in Progress |

Table 6-2. Status Register-2

| S15 | S14 | S13 | S12 | S11 | S10 | S9 | S8 |
|----------------|----------|----------|----------|----------|----------|-----------------------------|------------------------------------|
| SUS | (R) | (R) | (R) | (R) | (R) | QE | SRP1 |
| Suspend Status | Reserved | Reserved | Reserved | Reserved | Reserved | Quad Enable (Non- Volatile) | Register Protect 1 (Non- Volatile) |

6.1 Busy

BUSY is a read only bit in the status register (S0) that is set to a 1 state when the device is executing a Page Program, Erase, Write Status Register or Write Security Register instruction. During this time the device will ignore further instruction except for the Read Status Register and Erase / Program Suspend instruction (see tW, tPP, tSE, tBE1, tBE2 and tCE in AC Characteristics). When the Program, Erase, Write Status Register or Write Security Register instruction has completed, the BUSY bit will be cleared to a 0 state indicating the device is ready for further instructions.

6.2 Write Enable Latch (WEL)

Write Enable Latch (WEL) is a read only bit in the status register (S1) that is set to a 1 after executing a Write Enable instruction. The WEL status bit is cleared to a 0 when device is write disabled. A write disable state occurs upon power-up or after any of the following instructions: Write Disable, Page Program, Erase and Write Status Register.

6.3 Status Register Protect (SRP1, SRP0)

The Status Register Protect bits (SRP1 and SRP0) are non-volatile read/write bits in the status register (S8 and S7). The SRP bits control the method of write protection: software protection, hardware protection, power supply lock-down or one time programmable (OTP) protection.

| SRP1 | SRP0 | \overline{WP} | Status Register | Description |
|------|------|-----------------|----------------------|--|
| 0 | 0 | X | Software | \overline{WP} pin no control. The register can be written to |
| 0 | 1 | 0 | Hardware | When \overline{WP} pin is low the Status Register locked and can not |
| 0 | 1 | 1 | Hardware Unprotected | When \overline{WP} pin is high the Status register is unlocked and can be written to after a Write Enable instruction, WEL=1 |
| 1 | 0 | X | Power Supply | Status Register is protected and cannot be written to again until the next power down, power-up cycle(1) |
| 1 | 1 | X | One Time | Status Register is permanently protected and cannot be written to. |

Note: 1. When SRP1, SRP0=(1,0), a power down, power-up cycle will change SRP1, SRP0 to(0,0) state.

6.4 Quad Enable (QE)

The Quad Enable (QE) bit is a non-volatile read/write bit in the status register (S9) that allows Quad operation. When the QE bit is set to a 0 state (factory default) the \overline{WP} pin and \overline{HOLD} are enabled. When the QE pin is set to a 1 the Quad IO2 and IO3 pins are enabled. **WARNING : The QE bit should never be set to a 1 during standard SPI or Dual SPI operation if the \overline{WP} or \overline{HOLD} pins are tied directly to the power supply or ground.**

6.5 Erase/Program Suspend Status (SUS)

The Suspend Status bit (SUS) is a read only bit in the status register (S15) that is set to 1 after executing an Erase/Program Suspend (75h) instruction. The SUS status bit is cleared to 0 by Erase/Program Resume (7Ah) instruction as well as a power down, power-up cycle.

7. Instructions

The SPI instruction set of the AT25SL321 consists of thirty eight basic instructions and the QPI instruction set of the AT25SL321 consists of thirty one basic instructions that are fully controlled through the SPI bus (see Instruction Set table). Instructions are initiated with the falling edge of Chip Select (CS). The first byte of data clocked into the input pins (SI or IO [3:0]) provides the instruction code. Data on the SI input is sampled on the rising edge of clock with most significant bit (MSB) first.

Instructions are completed with the rising edge of edge \overline{CS} . Clock relative timing diagrams for each instruction are included in figures 8-1 through 8-66 All read instructions can be completed after any clocked bit. However, all instructions that Write, Program or Erase must complete on a byte (\overline{CS} driven high after a full 8-bit have been clocked) otherwise the instruction will be terminated. This feature further protects the device from inadvertent writes. Additionally, while the memory is being programmed or erased, or when the Status Register is being written, all instructions except for Read Register will be ignored until the program or erase cycle has completed.

Table 7-1. Manufacturer and Device Identification

| | | ID code | Instruction |
|------------------|-----------|---------|--------------------|
| Manufacturer ID | Adesto | 1Fh | 90h, 92h, 94h, 9Fh |
| Device ID | AT25SL321 | 15h | 90h, 92h, 94h, ABh |
| Memory Type ID | SPI / QPI | 42h | 9Fh |
| Capacity Type ID | 32M | 16h | 9Fh |

7.1 Instruction Set Tables

Table 7-2. Instruction Set Table 1 (SPI instruction)⁽¹⁾

| INSTRUCTION NAME | BYTE 1 | BYTE 2 | BYTE 3 | BYTE 4 | BYTE 5 | BYTE 6 |
|---------------------------|---------|---------------------------|------------|-----------|------------------------|----------|
| (CLOCK NUMBER) | (0 - 7) | (8 - 15) | (16 - 23) | (24 - 31) | (32 - 39) | (4 - 47) |
| Write Enable | 06h | | | | | |
| Write Enable For Volatile | 50h | | | | | |
| Write Disable | 04h | | | | | |
| Read Status Register-1 | 05h | (SR7-SR0) ⁽²⁾ | | | | |
| Read Status Register-2 | 35h | (SR15-SR8) ⁽²⁾ | | | | |
| Write Status Register-1 | 01h | (SR7-SR0) | (SR15-SR8) | | | |
| Write Status Register-2 | 31h | (SR15-SR8) | | | | |
| Read Data | 03h | A23-A16 | A15-A8 | A7-A0 | (D7-D0) | |
| Fast Read Data | 0Bh | A23-A16 | A15-A8 | A7-A0 | dummy | (D7-D0) |
| Page Program | 02h | A23-A16 | A15-A8 | A7-A0 | (D7-D0) ⁽³⁾ | |
| Enable QPI | 38h | | | | | |
| Block Erase(4KB) | 20h | A23-A16 | A15-A8 | A7-A0 | | |
| Block Erase(32KB) | 52h | A23-A16 | A15-A8 | A7-A0 | | |

7.1 Instruction Set Tables

Table 7-2. Instruction Set Table 1 (SPI instruction)⁽¹⁾

| | | | | | | |
|---|----------------|---------------------------|---------|------------|--------------------------|-------------|
| Block Erase(64KB) | D8h | A23-A16 | A15-A8 | A7-A0 | | |
| Chip Erase | 60h/C7h | | | | | |
| Erase/Program Suspend | 75h | | | | | |
| Erase/Program Resume | 7Ah | | | | | |
| Deep Power Down | B9h | | | | | |
| Release Deep power down/ Device ID ⁽⁴⁾ | ABh | dummy | dummy | dummy | (ID7-ID0) ⁽²⁾ | |
| Read Manufacturer/ Device ID ⁽⁴⁾ | 90h | 00h | 00h | 00h or 01h | (MID7-MID0) | (DID7-DID0) |
| Read JEDEC ID | 9Fh | (MID7-MID0) | (D7-D0) | (D7-D0) | | |
| Reset Enable | 66h | | | | | |
| Reset | 99h | | | | | |
| Enter Secured OTP | B1h | | | | | |
| Exit Secured OTP | C1h | | | | | |
| Read Security Register | 2Bh | (SC7-SC0) ⁽¹⁰⁾ | | | | |
| Write Security Register | 2Fh | | | | | |
| Read Serial Flash Discovery Parameter | 5Ah | A23-A16 | A15-A8 | A7-A0 | dummy | (D7-D0) |

Table 7-3. Instruction Set Table 2 (Dual SPI Instruction)

| INSTRUCTION (CLOCK NUMBER) | (0 - 7) | (8 - 15) | (16 - 23) | (24 - 31) | (32 - 39) | (40 - 47) |
|--|------------|-----------------------|----------------------------|--|-----------|------------------------|
| Fast Read Dual Output | 3Bh | A23-A16 | A15-A8 | A7-A0 | dummy | (D7-D0) ⁽⁶⁾ |
| Fast Read Dual I/O | BBh | A23-A8 ⁽⁵⁾ | A7-A0, | (D7-D0, ...) ⁽⁶⁾ | | |
| Read Dual Manufacturer/ Device ID ⁽⁴⁾ | 92h | 0000h | (00h, xxxx) or (01h, xxxx) | (MID7-MID0) (DID7-DID0) ⁽⁶⁾ | | |

Table 7-4. Instruction Set Table 3 (Quad SPI Instruction)

| INSTRUCTION (CLOCK NUMBER) | (0 - 7) | (8 - 15) | (16 - 23) | (24 - 31) | (32 - 39) | (40 - 47) |
|----------------------------|------------|------------------------------------|---------------------------------|-----------------------------|-----------|------------------------|
| Fast Read Quad Output | 6Bh | A23-A16 | A15-A8 | A7-A0 | dummy | (D7-D0) ⁽⁸⁾ |
| Fast Read Quad I/O | EBh | A23-A0, M7-M0 ⁽⁷⁾ | (xxx, D7-D0,...) ⁽⁹⁾ | (D7-D0, ...) ⁽⁸⁾ | | |
| Quad Page Program | 33h | A23-A0 (D7-D0, ...) ⁽⁸⁾ | | | | |

Table 7-4. Instruction Set Table 3 (Quad SPI Instruction)

| | | | | | |
|--|------------|--|--|------------------------|--|
| Read Quad Manufacturer /Device ID ⁽⁴⁾ | 94h | (00_0000h, xx) or (00_0001h, xx) | (xxxx, MID7-MID0) (xxxx, DID7-DID0) ⁽⁹⁾ | | |
| Word Read Quad I/O | E7h | A23-A0, M7-M0 ⁽⁷⁾ | (xx, D7-D0..) | (D7-D0) ⁽⁸⁾ | |
| Set Burst with Wrap | 77h | xxxxxx, W6- W4 ⁽⁷⁾ | | | |

Table 7-5. Instruction Set Table 4 (QPI instruction)

| INSTRUCTION | | BYTE 1 | BYTE 2 | BYTE 3 | BYTE 4 | BYTE 5 | BYTE 6 | BYTE 7 | BYTE 8 | BYTE 9 |
|--|---------|---------------------|---------------------------------|---------------------------|-----------------------------|------------------------|-----------------|----------|----------|----------|
| (CLOCK NUMBER) | | (0, 1) | (2, 3) | (4, 5) | (6, 7) | (8, 9) | (10, 11) | (12, 13) | (14, 15) | (16, 17) |
| Write Enable | | 06h | | | | | | | | |
| Write Enable for Volatile | | 50h | | | | | | | | |
| Write Disable | | 04h | | | | | | | | |
| Read Status Register-1 | | 05h | (SR7- SR0) ⁽²⁾ | | | | | | | |
| Read Status Register-2 | | 35h | (SR15- SR8) ⁽²⁾ | | | | | | | |
| Write Status Register-1 ⁽⁵⁾ | | 01h | (SR7- SR0) | (SR15- SR8) | | | | | | |
| Write Status Register-2 | | 31h | (SR15- SR8) | | | | | | | |
| Fast Read Data | >80MHz | 0Bh | A23-A16 | A15-A8 | A7-A0 | dummy | dummy | (D7-D0) | | |
| | >104MHz | | A23-A16 | A15-A8 | A7-A0 | dummy | dummy | dummy | (D7-D0) | |
| Page Program | | 02h | A23-A16 | A15-A8 | A7-A0 | (D7-D0) ⁽³⁾ | | | | |
| Block Erase(4KB) | | 20h | A23-A16 | A15-A8 | A7-A0 | | | | | |
| Block Erase(32KB) | | 52h | A23-A16 | A15-A8 | A7-A0 | | | | | |
| Block Erase(64KB) | | D8h | A23-A16 | A15-A8 | A7-A0 | | | | | |
| Chip Erase | | 60h/ C7h | | | | | | | | |
| Erase/Program Suspend | | 75h | | | | | | | | |
| Erase/Program Resume | | 7Ah | | | | | | | | |
| Deep Power Down | | B9h | | | | | | | | |
| Release Deep Power Down | | ABh | | | | | | | | |
| Read Manufacturer/Device ID ⁽⁴⁾ | | 90h | 00h | 00h | 00h or 01h | (MID7- MID0) | (DID7- DID0) | | | |
| Read JEDEC ID ⁽⁴⁾ | | 9Fh | (MID7- MID0) Manufacturer | (D7-D0) Memory Type | (D7-D0) Capacity Type | | | | | |
| Enter Security | | B1h | | | | | | | | |
| Exit Security | | C1h | | | | | | | | |

Table 7-5. Instruction Set Table 4 (QPI instruction)

| | | | | | | | | | | |
|-------------------------|---------|-----|---------------------------|--------|-------|---------|-------|---------|---------|--|
| Read Security Register | | 2Bh | (SC7-SC0) ⁽¹⁰⁾ | | | | | | | |
| Write Security Register | | 2Fh | | | | | | | | |
| Fast Read Quad I/O | >80MHz | EBh | A23-A16 | A15-A8 | A7-A0 | (M7-M0) | dummy | (D7-D0) | | |
| | >104MHz | | A23-A16 | A15-A8 | A7-A0 | (M7-M0) | dummy | dummy | (D7-D0) | |
| Reset Enable | | 66h | | | | | | | | |
| Reset | | 99h | | | | | | | | |
| Disable QPI | | FFh | | | | | | | | |
| Burst Read with Wrap | >80MHz | 0Ch | A23-A16 | A15-A8 | A7-A0 | dummy | dummy | (D7-D0) | | |
| | >104MHz | | A23-A16 | A15-A8 | A7-A0 | dummy | dummy | dummy | (D7-D0) | |
| Set Read Parameter | | C0h | P7-P0 | | | | | | | |
| Quad Page Program | | 33h | A23-A16 | A15-A8 | A7-A0 | (D7-D0) | | | | |

Notes:

- Data bytes are shifted with Most Significant Bit first. Byte fields with data in parenthesis “()” indicate data being read from the device on the IO pin.
- SR = status register, The Status Register contents and Device ID will repeat continuously until \overline{CS} terminates the instruction.
- At least one byte of data input is required for Page Program, Quad Page Program and Program Security Register, up to 256 bytes of data input. If more than 256 bytes of data are sent to the device, the addressing will wrap to the beginning of the page and overwrite previously sent data.
- See Manufacturer and Device Identification table for Device ID information.
- Dual Input Address
 IO0 = A22, A20, A18, A16, A14, A12, A10, A8, A6, A4, A2, A0, M6, M4, M2, M0
 IO1 = A23, A21, A19, A17, A15, A13, A11, A9, A7, A5, A3, A1, M7, M5, M3, M1
- Dual Output data
 IO0 = (D6, D4, D2, D0)
 IO1 = (D7, D5, D3, D1)
- Quad Input Address

| | |
|--|-------------------------------|
| | Set Burst with Wrap Input |
| IO0 = A20, A16, A12, A8, A4, A0, M4, M0 | IO0 = x, x, x, x, x, x, W4, x |
| IO1 = A21, A17, A13, A9, A5, A1, M5, M1 | IO1 = x, x, x, x, x, x, W5, x |
| IO2 = A22, A18, A14, A10, A6, A2, M6, M2 | IO2 = x, x, x, x, x, x, W6, x |
| IO3 = A23, A19, A15, A11, A7, A3, M7, M3 | IO3 = x, x, x, x, x, x, x, x |
- Quad Input/ Output Data
 IO0 = (D4, D0...)
 IO1 = (D5, D1...)
 IO2 = (D6, D2...)
 IO3 = (D7, D3...)
- Fast Read Quad I/O Data Output
 IO0 = (x, x, x, x, D4, D0...)
 IO1 = (x, x, x, x, D5, D1...)
 IO2 = (x, x, x, x, D6, D2...)
 IO3 = (x, x, x, x, D7, D3...)
- SC = security register

7.2 Write Enable (06h)

Write Enable instruction is for setting the Write Enable Latch (WEL) bit in the Status Register. The \overline{WEL} bit must be set prior to every Program, Erase and Write Status Register instruction. To enter the Write Enable instruction, \overline{CS} goes low prior to the instruction “06h” into Data Input (SI) pin on the rising edge of SCK, and then driving \overline{CS} high.

Figure 7-1. Write Enable Instruction for SPI Mode (left) and QPI Mode (right)

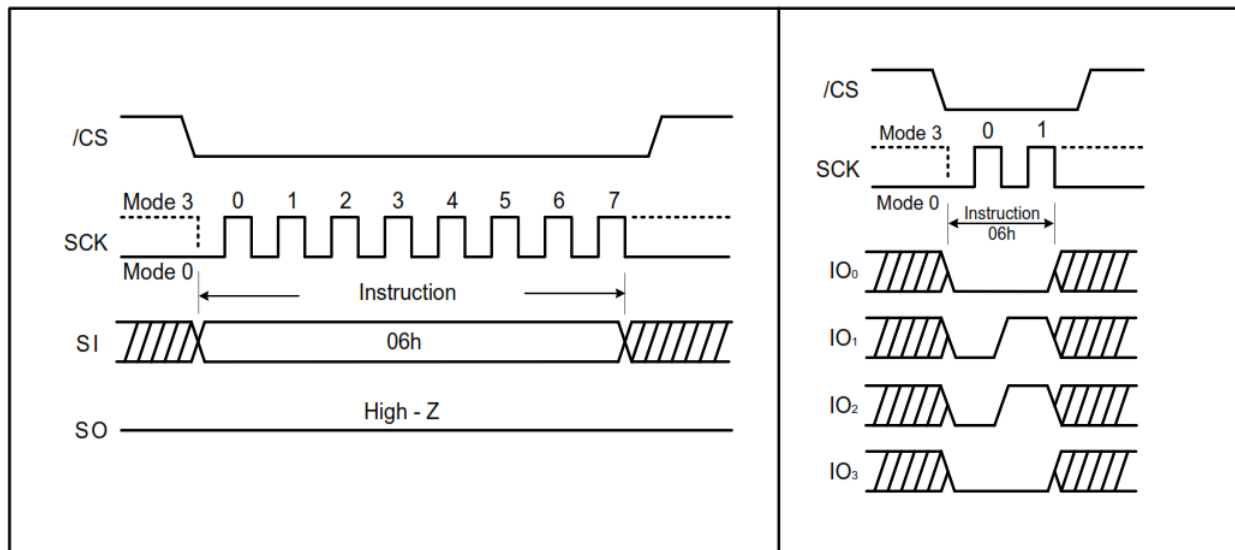

7.3 Write Enable for Volatile Status Register (50h)

This gives more flexibility to change the system configuration and memory protection schemes quickly without waiting for the typical non-volatile bit write cycles or affecting the endurance of the Status Register non-volatile bits. To write the volatile values into the Status Register bits, the Write Enable for Volatile Status Register (50h) instruction must be issued prior to a Write Status Register (01h) instruction. Write Enable for Volatile Status Register instruction (Figure 7-2) will not set the Write Enable Latch (WEL) bit. Once Write Enable for Volatile Status Register is set, a Write Enable instruction should not have been issued prior to setting Write Status Register instruction (01h or 31h). When Write Enable for Volatile Status Register (50h) is set in QPI Mode, the SUS bit (S15) and Reserved bits (S13, S12, S11 and S10) of the Status Register-2 must be driven to high after Write Status Register instruction (01h). Once Read Status Register (05h or 31h) is issued, the read values of SUS bit (S15) and Reserved bits (S13, S12, S11 and S10) of the Status Register-2 are ignored.

Figure 7-2. Write Enable for Volatile Status Register Instruction for SPI Mode (left) and QPI Mode (right)

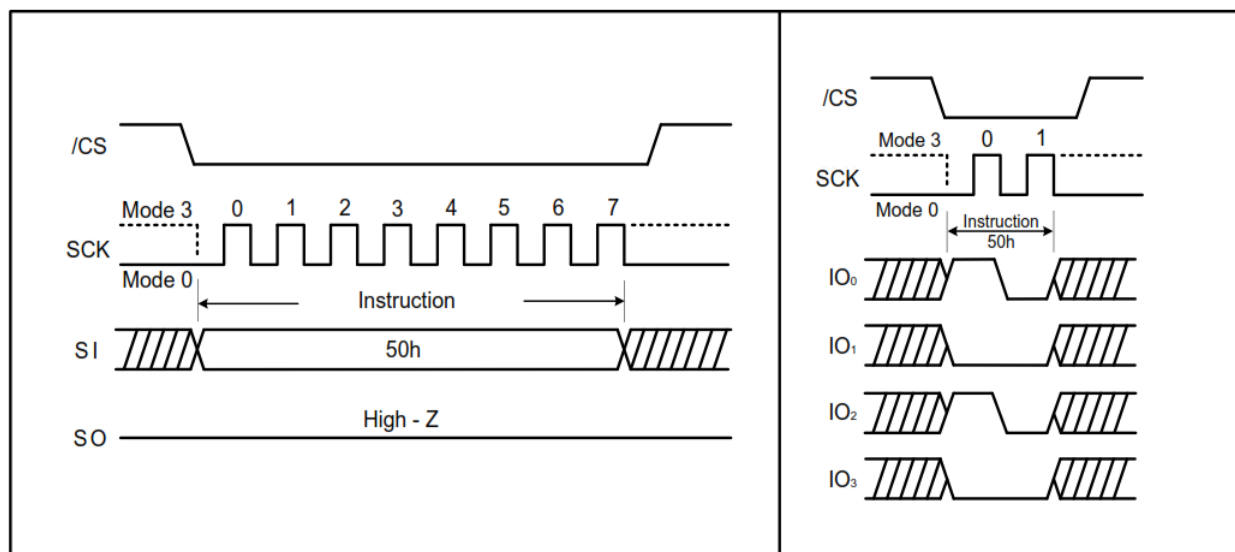

7.4 Write Disable (04h)

The Write Disable instruction is to reset the Write Enable Latch (WEL) bit in the Status Register. To enter the Write Disable instruction, \overline{CS} goes low prior to the instruction "04h" into Data Input (SI) pin on the rising edge of SCK, and then driving \overline{CS} high. WEL bit is automatically reset write-disable status of "0" after Power-up and upon completion of the every Program, Erase and Write Status Register instructions.

Figure 7-3. Write Disable Instruction for SPI Mode (left) and QPI Mode (right)

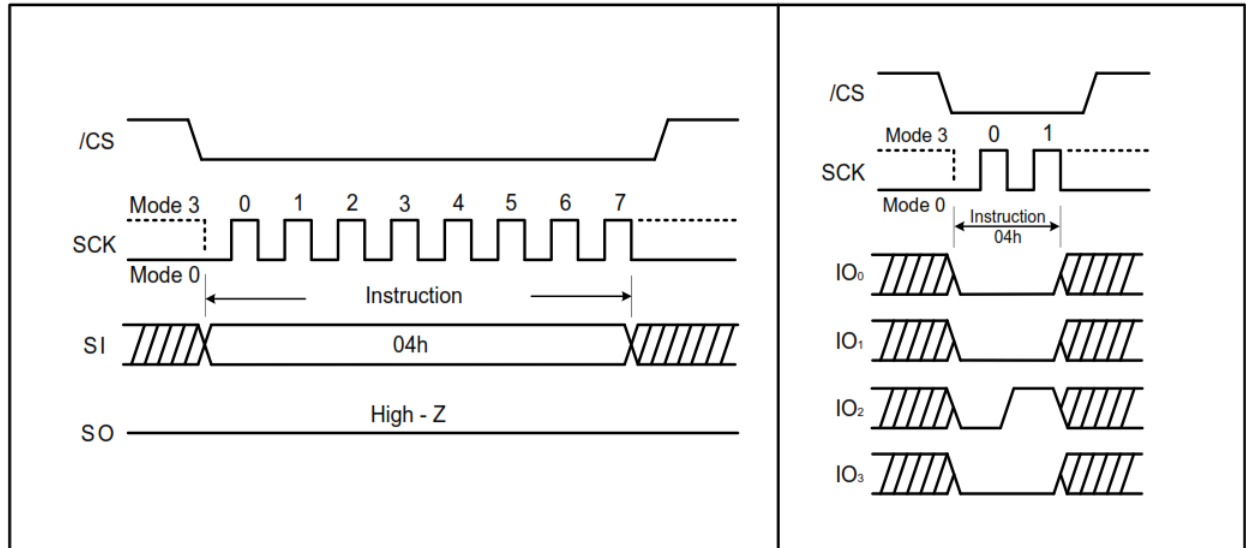

7.5 Read Status Register-1 (05h) and Read Status Register-2 (35h)

The Read Status Register instructions are to read the Status Register. The Read Status Register can be read at any time (even in program/erase/write Status Register and Write Security Register condition). It is recommended to check the BUSY bit before sending a new instruction when a Program, Erase, Write Status Register or Write Security Register operation is in progress.

The instruction is entered by driving \overline{CS} low and sending the instruction code "05h" for Status Register-1 or "35h" for Status Register-2 into the SI pin on the rising edge of SCK. The status register bits are then shifted out on the SO pin at the falling edge of SCK with most significant bit (MSB) first as shown in (Figure 7-4 and Figure 7-5). The Status Register can be read continuously. The instruction is completed by driving \overline{CS} high.

Figure 7-4. Read Status Register Instruction (SPI Mode)

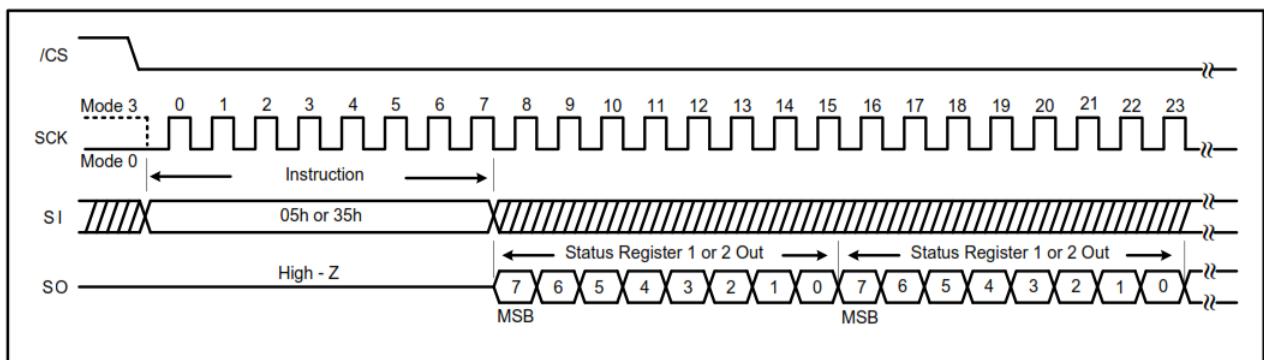
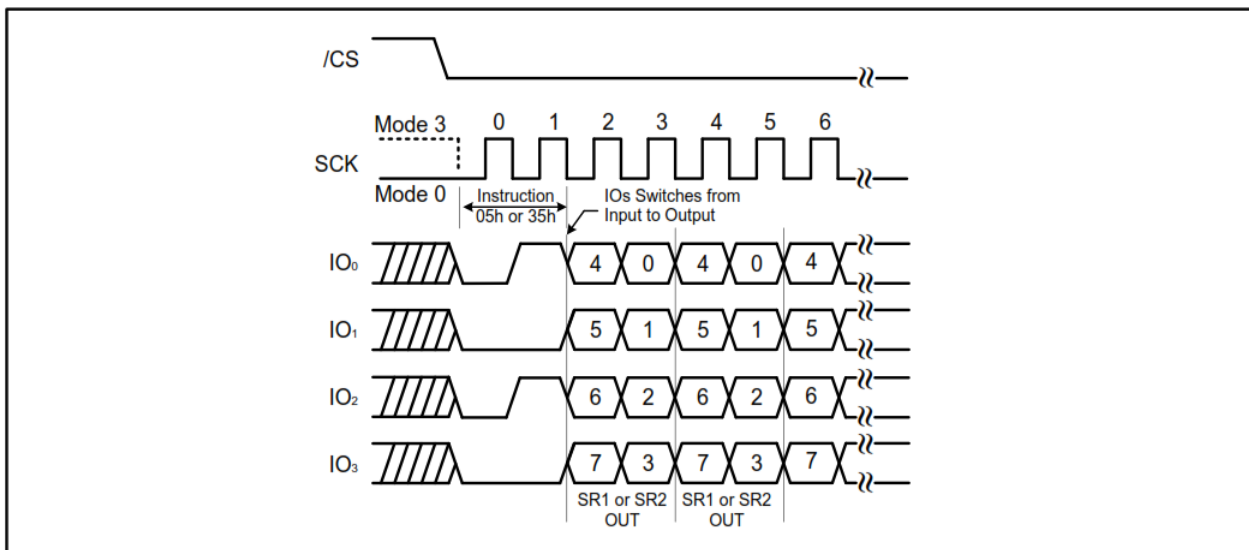

Figure 7-5. Read Status Register Instruction (QPI Mode)



7.6 Write Status Register (01h)

The Write Status Register instruction is to write only non-volatile Status Register-1 bits (SRP0) and Status Register-2 bits (QE and SRP1). All other Status Register bit locations are read-only and will not be affected by the Write Status Register instruction.

A Write Enable instruction must previously have been issued prior to setting Write Status Register Instruction (Status Register bit WEL must equal 1). Once write is enabled, the instruction is entered by driving \overline{CS} low, sending the instruction code, and then writing the status register data byte as illustrated in Figure 7-6 and Figure 7-7.

The \overline{CS} pin must be driven high after the eighth or sixteenth bit of data that is clocked in. If this is not done the Write Status Register instruction will not be executed. If \overline{CS} is driven high after the eighth clock, the CMP QE and SRP1 bits will be cleared to 0. After \overline{CS} is driven high, the self-timed Write Status Register cycle will commence for a time duration of t_w (See AC Characteristics).

While the Write Status Register cycle is in progress, the Read Status Register instruction may still be accessed to check the status of the BUSY bit. The BUSY bit is a 1 during the Write Status Register cycle and a 0 when the cycle is finished and ready to accept other instructions again. When the BUSY bit is asserted, the Write Enable Latch (WEL) bit in Status Register will be cleared to 0.

Figure 7-6. Write Status Register Instruction (SPI Mode)

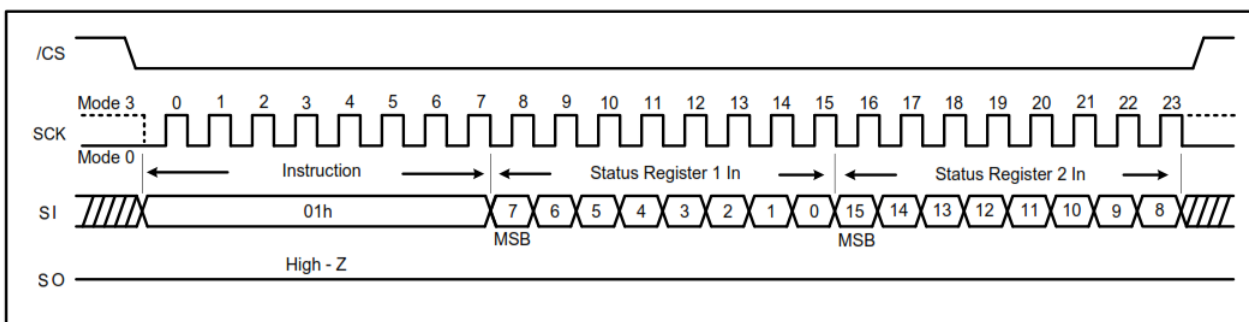
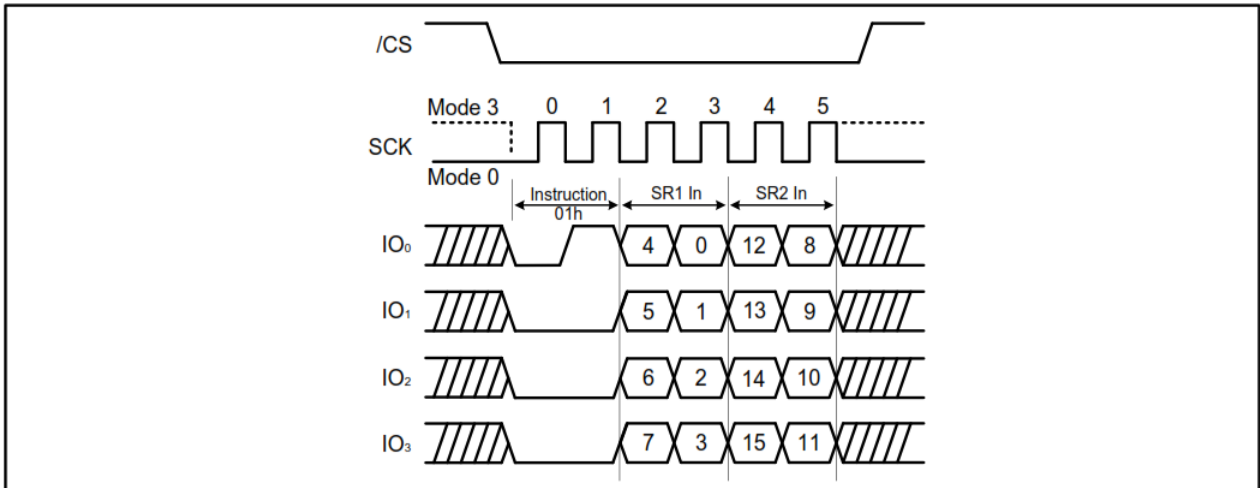

Figure 7-7. Write Status Register Instruction (QPI Mode)



7.7 Write Status Register-2 (31h)

The Write Status Register-2 instruction is to write only non-volatile Status Register-2 bits (CMP, QE and SRP1).

A Write Enable instruction must previously have been issued prior to setting Write Status Register Instruction (Status Register bit WEL must equal 1). Once write is enabled, the instruction is entered by driving \overline{CS} low, sending the instruction code, and then writing the status register data byte as illustrated in Figure 7-8 and Figure 7-9.

Using Write Status Register-2 (31h) instruction, software can individually access each one-byte status registers via different instructions.

Figure 7-8. Write Status Register-2 Instruction (SPI Mode)

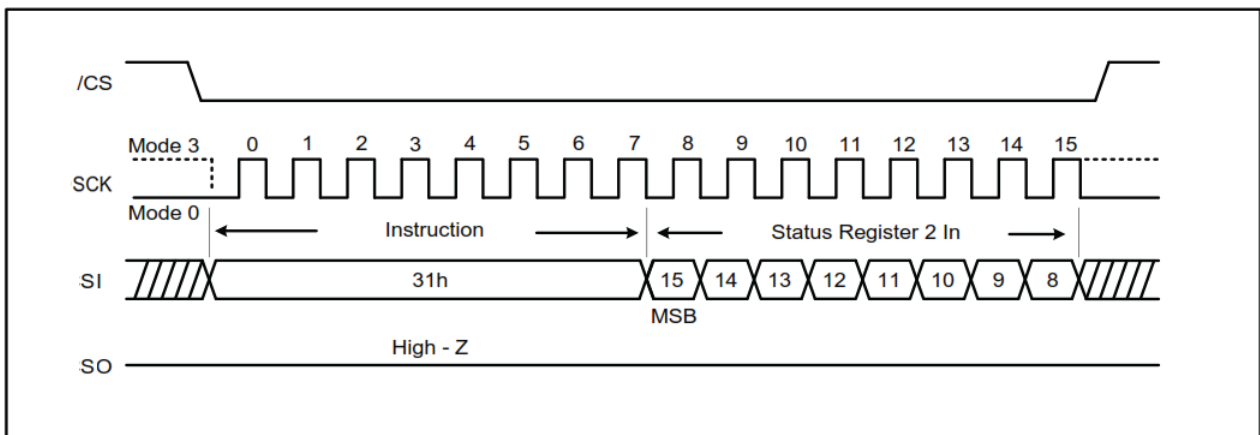
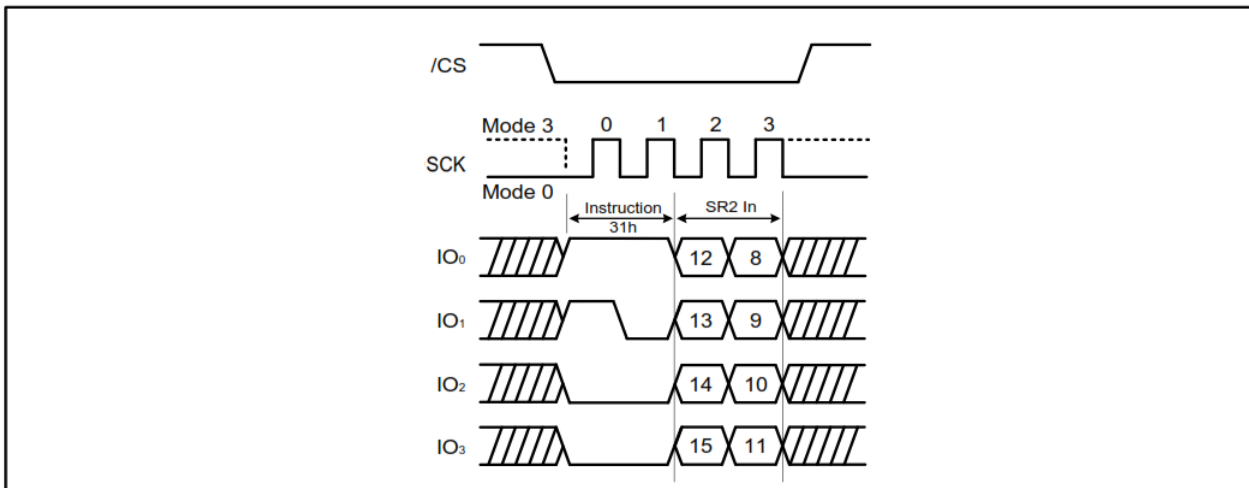

Figure 7-9. Write Status Register-2 Instruction (QPI Mode)



7.8 Read Data (03h)

The Read Data instruction is to read data out from the device. The instruction is initiated by driving the \overline{CS} pin low and then sending the instruction code “03h” with following a 24-bit address (A23- A0) into the SI pin. After the address is received, the data byte of the addressed memory location will be shifted out on the SO pin at the falling edge of SCK with most significant bit (MSB) first. The address is automatically incremented to the next higher address after byte of data is shifted out allowing for a continuous stream of data. This means that the entire memory can be accessed with a single instruction as long as the clock continues. The instruction is completed by driving \overline{CS} high. The Read Data instruction sequence is shown in Figure 7-10. If a Read Data instruction is issued while an Erase, Program or Write Status Register cycle is in process (BUSY=1) the instruction is ignored and will not have any effects on the current cycle. The Read Data instruction allows clock rates from D.C to a maximum of f_R (see AC Electrical Characteristics).

Figure 7-10. Read Data Instruction

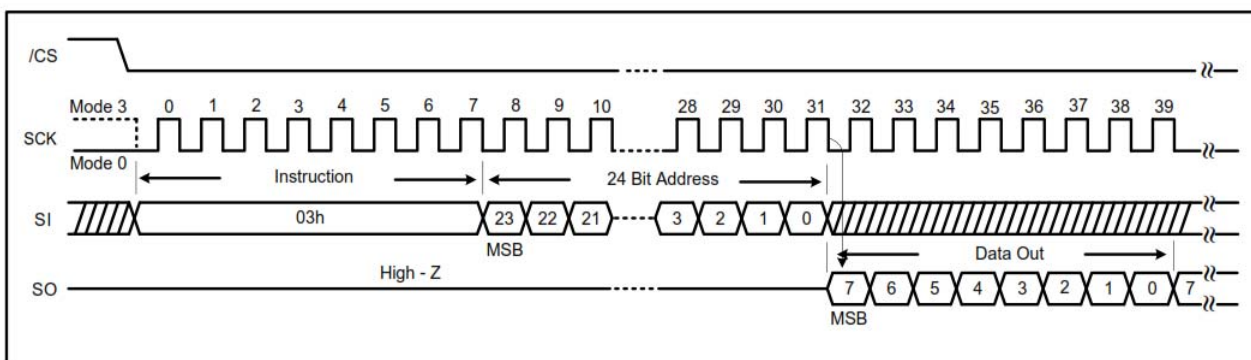

7.9 Fast Read (0Bh)

The Fast Read instruction is high speed reading mode that it can operate at the highest possible frequency of F_R . The address is latched on the rising edge of the SCK. After the 24-bit address, this is accomplished by adding “dummy” clocks as shown in Figure 7-11. The dummy clocks means the internal circuits require time to set up the initial address. During the dummy clocks, the data value on the SO pin is a “don’t care”. Data of each bit shifts out on the falling edge of SCK.

Figure 7-11. Fast Read Instruction (SPI Mode)

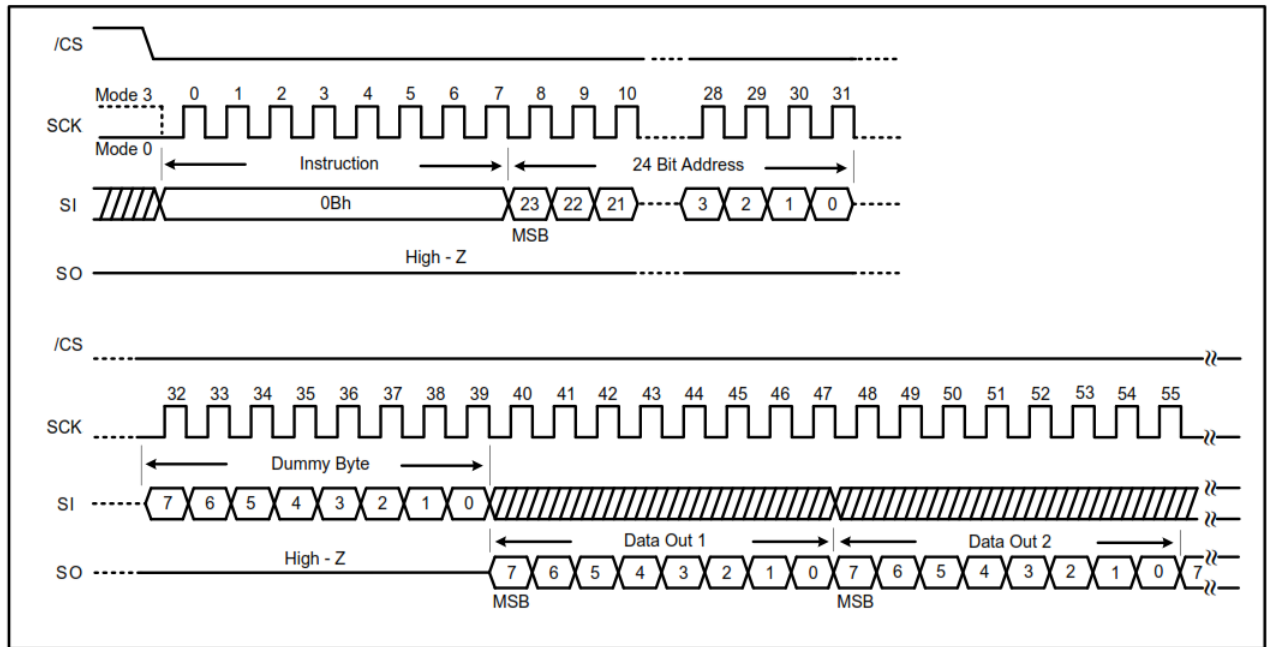

7.10 Fast Read in QPI Mode

When QPI mode is enabled, the number of dummy clock is configured by the “Set Read Parameters (C0h)” instruction to accommodate wide range applications with different needs for either maximum Fast Read frequency or minimum data access latency. Depending on the Read Parameter Bit P[4] and P[5] setting, the number of dummy clocks can be configured as either 4, or 6 or 8. The default number of dummy clocks upon power up or after a Reset instruction is 4. (Please refer to [Figure 7-12](#), [Figure 7-13](#) and [Figure 7-13](#)).

Figure 7-12. Fast Read instruction (QPI Mode, 80MHz)

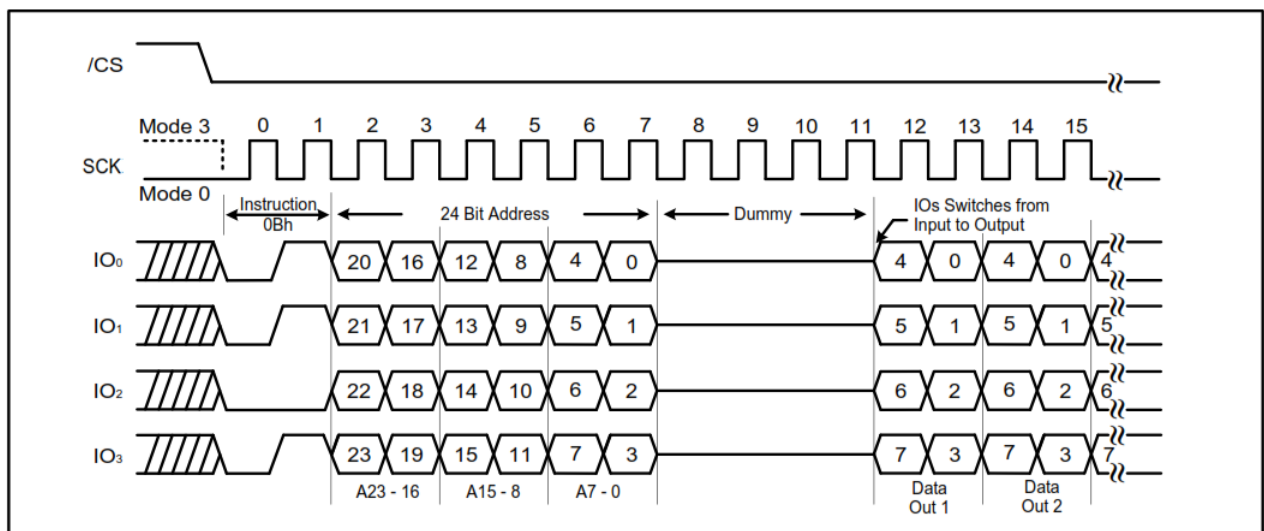
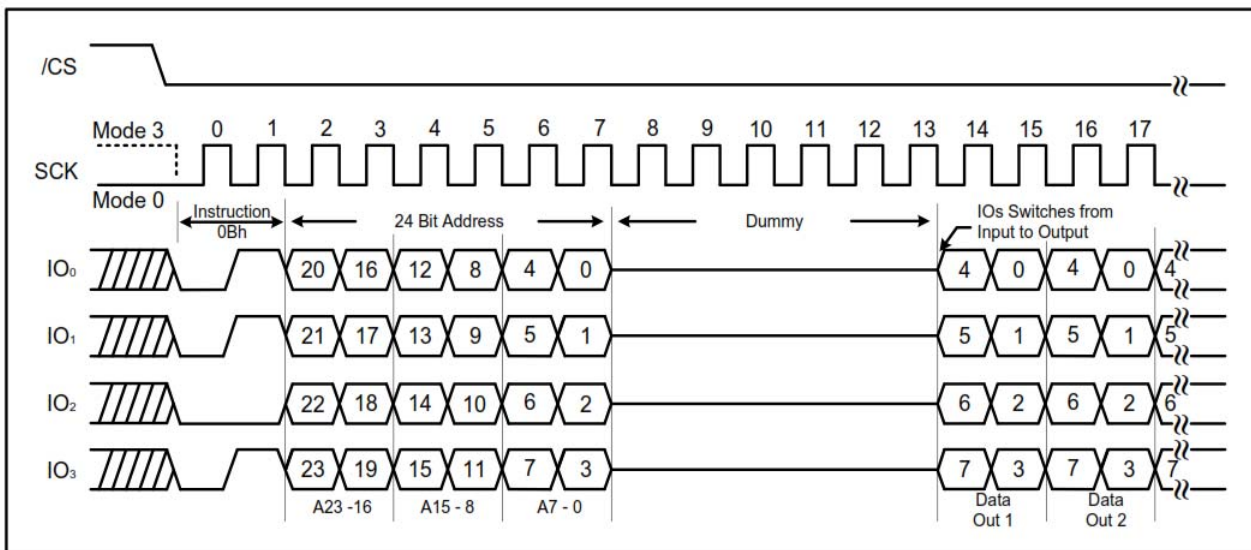

Figure 7-13. Fast Read instruction (QPI Mode, 104MHz)



7.11 Fast Read Dual Output (3Bh)

By using two pins (IO₀ and IO₁, instead of just IO₀), The Fast Read Dual Output instruction allows data to be transferred from the AT25SL321 at twice the rate of standard SPI devices. The Fast Read Dual Output instruction is ideal for quickly downloading code from Flash to RAM upon power-up or for application that cache code-segments to RAM for execution.

The Fast Read Dual Output instruction can operate at the highest possible frequency of F_R (see AC Electrical Characteristics). After the 24-bit address, this is accomplished by adding eight “dummy” clocks as shown in Figure 7-14. The dummy clocks allow the internal circuits additional time for setting up the initial address. During the dummy clocks, the data value on the SO pin is a “don’t care”. However, the IO₀ pin should be high-impedance prior to the falling edge of the first data out clock.

Figure 7-14. Fast Read Dual Output instruction (SPI Mode)

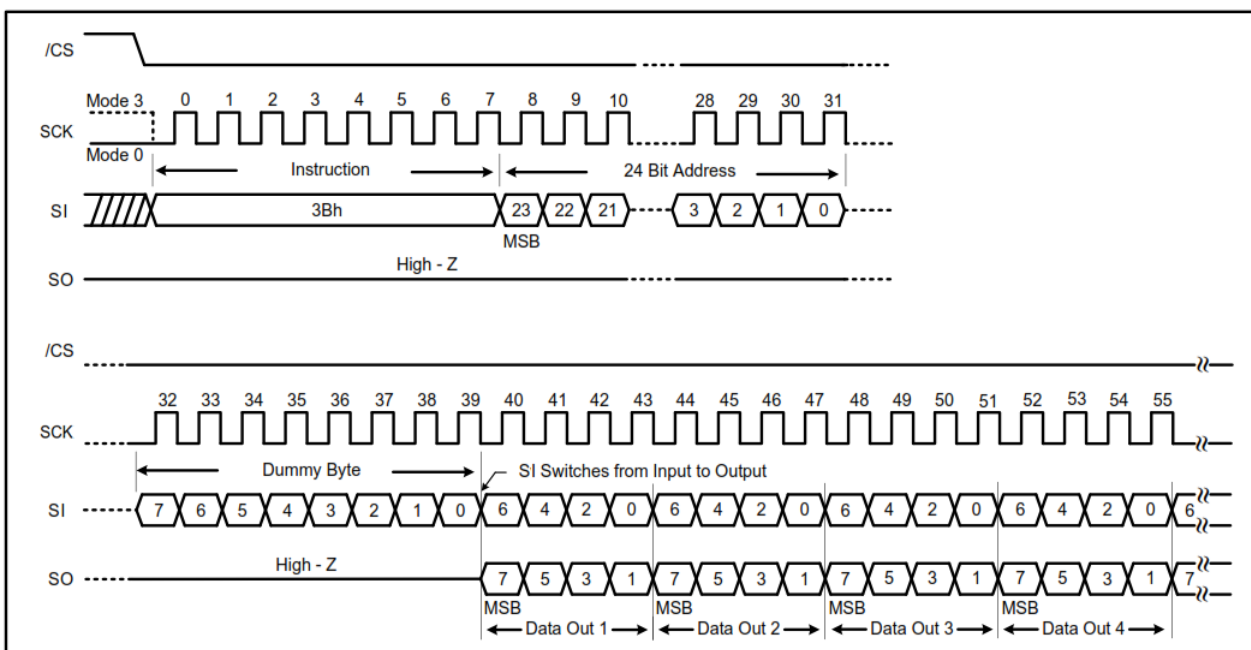

7.12 Fast Read Quad Output (6Bh)

By using four pins (IO₀, IO₁, IO₂, and IO₃), The Fast Read Quad Output instruction allows data to be transferred from the AT25SL321 at four times the rate of standard SPI devices. A Quad enable of Status Register-2 must be executed before the device will accept the Fast Read Quad Output instruction (Status Register bit QE must equal 1).

The Fast Read Quad Output instruction can operate at the highest possible frequency of F_R (see AC Electrical Characteristics). This is accomplished by adding eight “dummy” clocks after the 24-bit address as shown in Figure 7-15. The dummy clocks allow the internal circuits additional time for setting up the initial address. During the dummy clocks, the data value on the SO pin is a “don’t care”. However, the IO₀ pin should be high-impedance prior to the falling edge of the first data out clock.

Figure 7-15. Fast Read Quad Output instruction (SPI Mode)

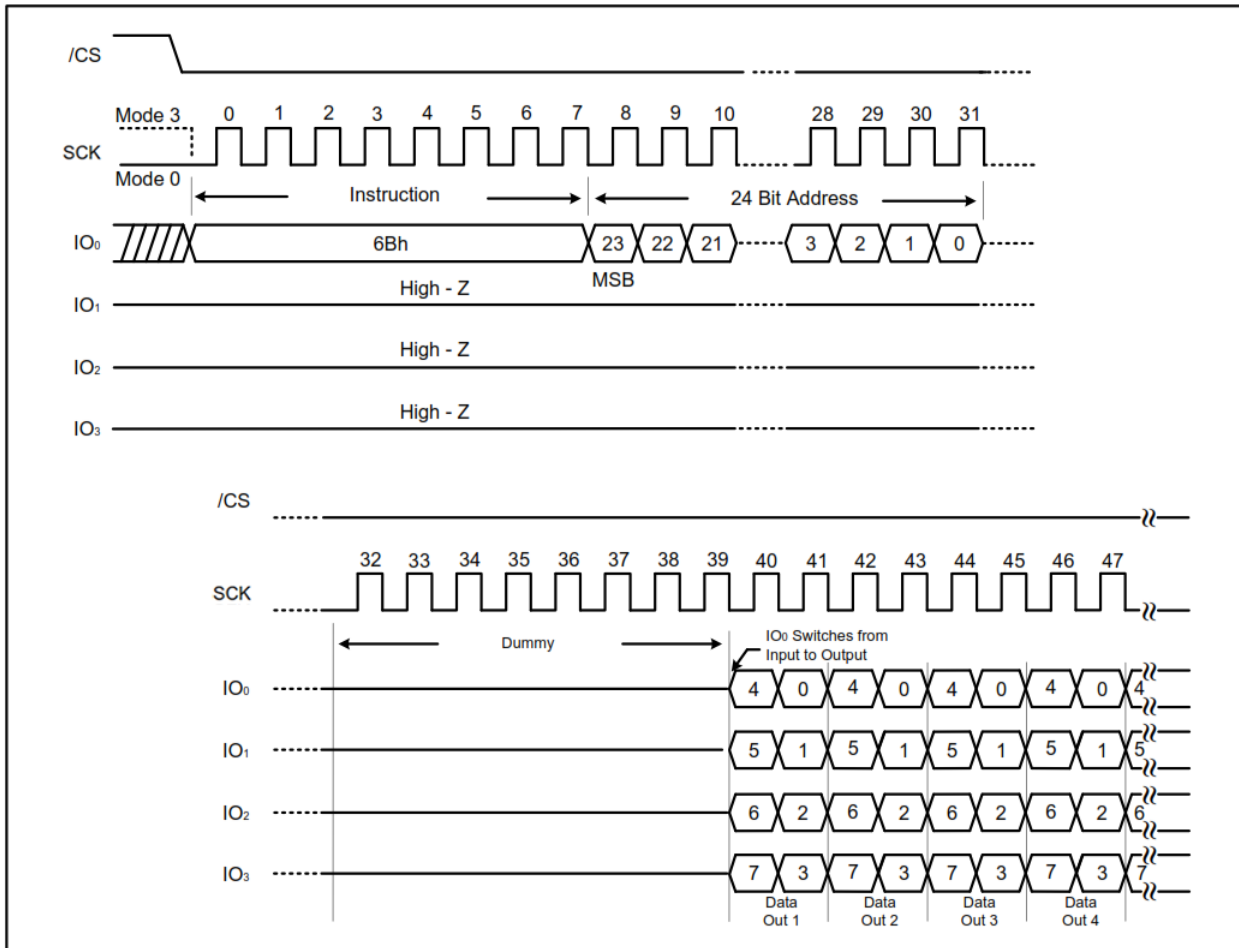

7.13 Fast Read Dual I/O (BBh)

The Fast Read Dual I/O instruction reduces cycle overhead through double access using two IO pins: IO₀ and IO₁.

Continuous read mode

The Fast Read Dual I/O instruction can further reduce cycle overhead through setting the Mode bits (M7-0) after the input Address bits (A23-0). The upper nibble of the Mode (M7-4) controls the length of the next Fast Read Dual I/O instruction through the inclusion or exclusion of the first byte instruction code. The lower nibble bits of the Mode (M3-0) are don't care (“X”), However, the IO pins should be high-impedance prior to the falling edge of the first data out clock.

If the Mode bits (M7-0) equal "Ax" hex, then the next Fast Dual I/O instruction (after \overline{CS} is raised and then lowered) does not require the instruction (BBh) code, as shown in Figure 7-16 and Figure 7-17. This reduces the instruction sequence by eight clocks and allows the address to be immediately entered after \overline{CS} is asserted low. If Mode bits (M7-0) are any value other "Ax" hex, the next instruction (after \overline{CS} is raised and then lowered) requires the first byte instruction code, thus returning to normal operation. A Mode Bit Reset can be used to reset Mode Bits (M7-0) before issuing normal instructions.

Figure 7-16. Fast Read Dual I/O Instruction (initial instruction or previous M7-0 \neq Axh)

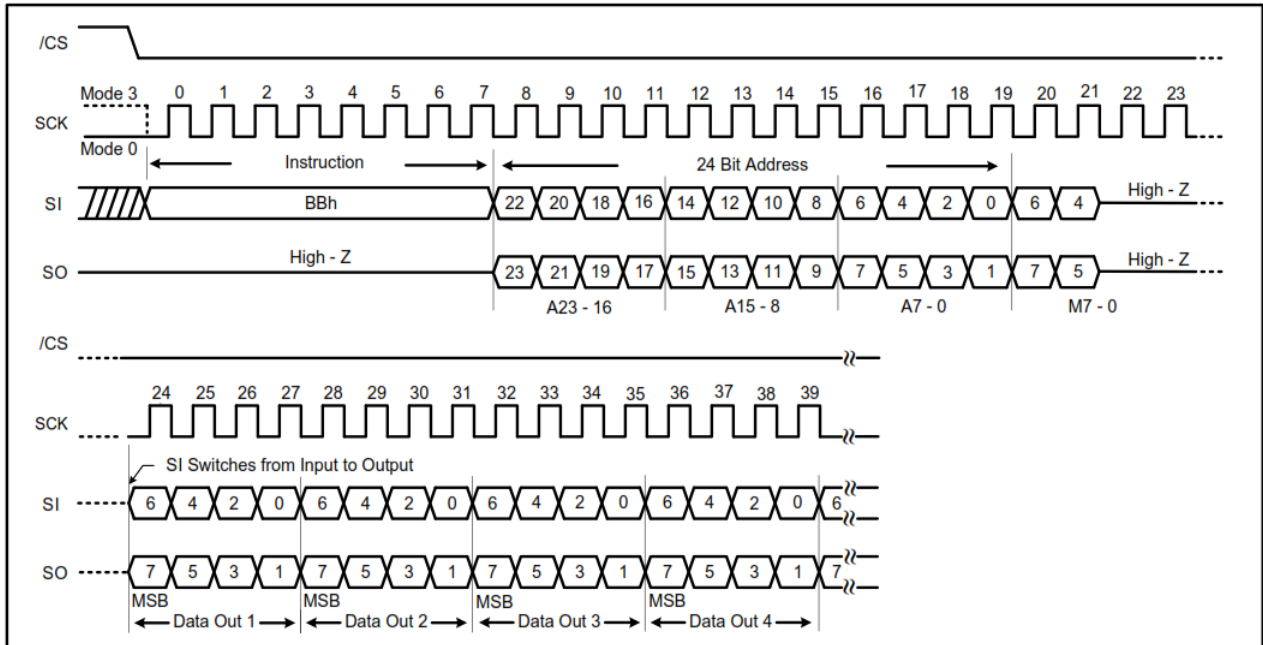
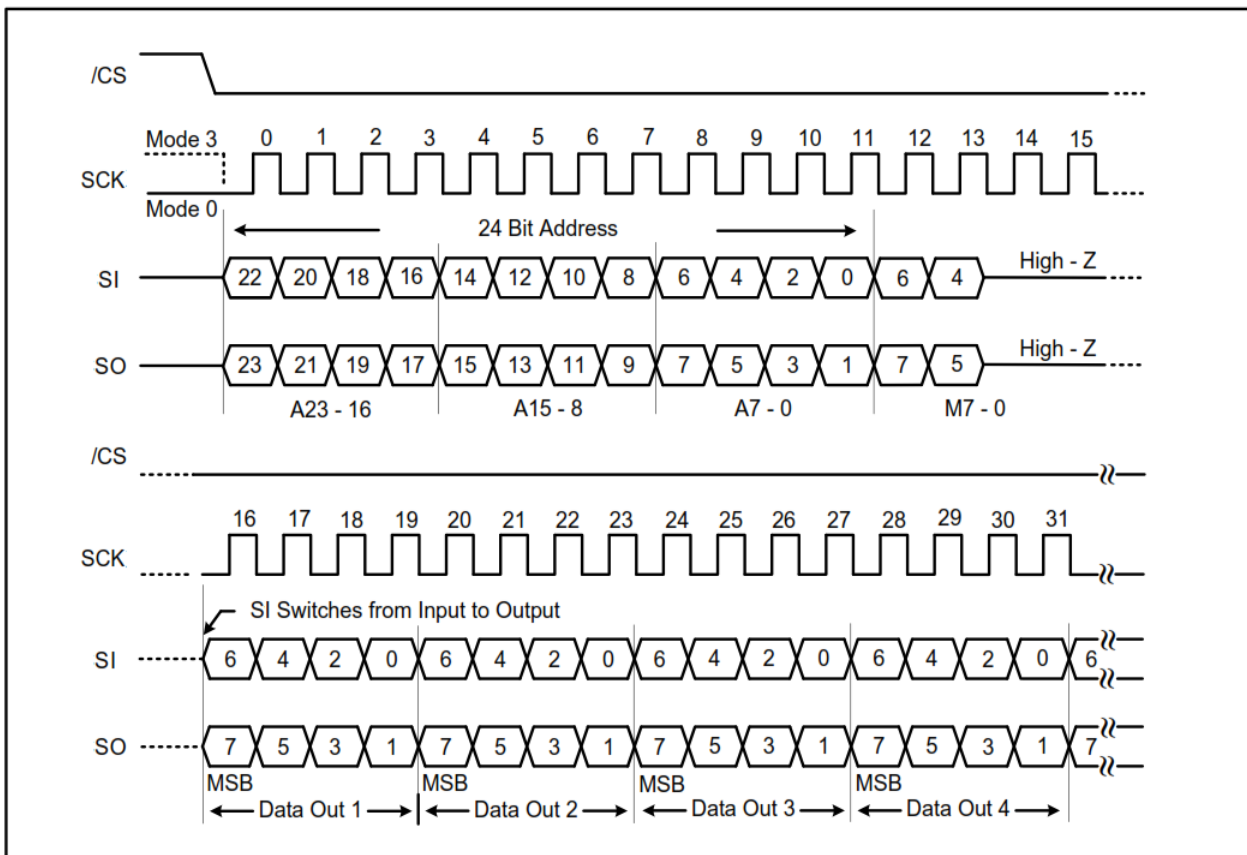

Figure 7-17. Fast Read Dual I/O Instruction (previous M7-0= Axh)



7.14 Fast Read Quad I/O (EBh)

The Fast Read Quad I/O instruction reduces cycle overhead through quad access using four IO pins: IO₀, IO₁, IO₂, and IO₃. The Quad Enable bit (QE) of Status Register-2 must be set to enable the Fast read Quad I/O Instruction.

Continuous read mode

The Fast Read Quad I/O instruction can further reduce instruction overhead through setting the Mode bits (M7-0) with following the input Address bits (A23-0), as shown in Figure 7-18. The upper nibble of the Mode (M7-4) controls the length of the next Fast Read Quad I/O instruction through the inclusion or exclusion of the first byte instruction code. The lower nibble bits of the Mode (M3-0) are don't care ("X"). However, the IO pins should be high-impedance prior to the falling edge of the first data out clock.

If the Mode bits (M7-0) equal "Ax" hex, then the next Fast Read Quad I/O instruction (after \overline{CS} is raised and then lowered) does not require the EBh instruction code, as shown in Figure 7-19. This reduces the instruction sequence by eight clocks and allows the address to be immediately entered after \overline{CS} is asserted low. If the Mode bits (M7-0) are any value other than "Ax" hex, the next instruction (after \overline{CS} is raised and then lowered) requires the first byte instruction code, thus retuning normal operation. A Mode Bit Reset can be used to reset Mode Bits (M7-0) before issuing normal instructions.

Figure 7-18. Fast Read Quad I/O Instruction (Initial instruction or previous M7-0 ≠ Axx, SPI mode)

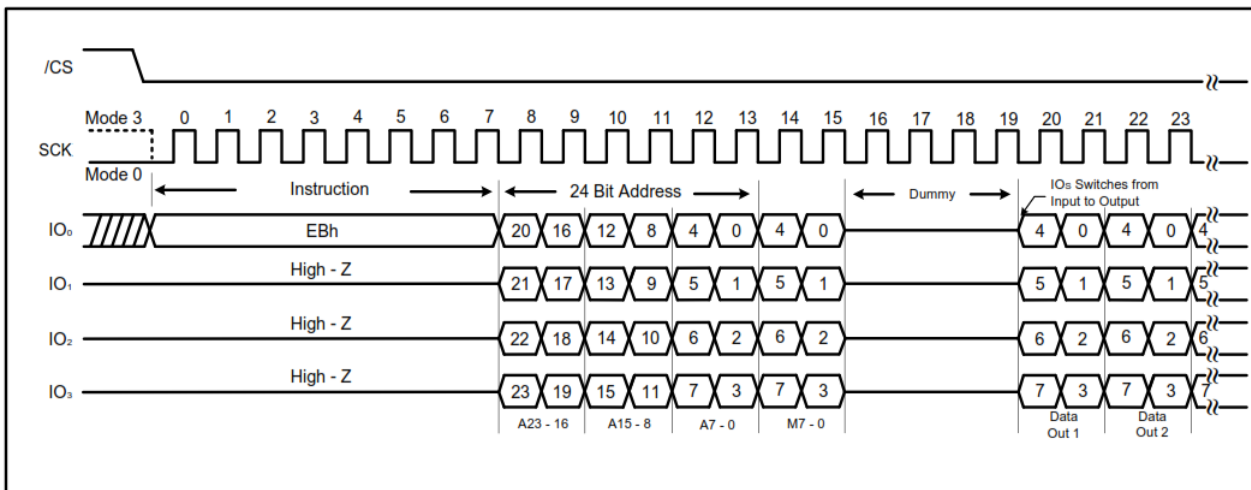
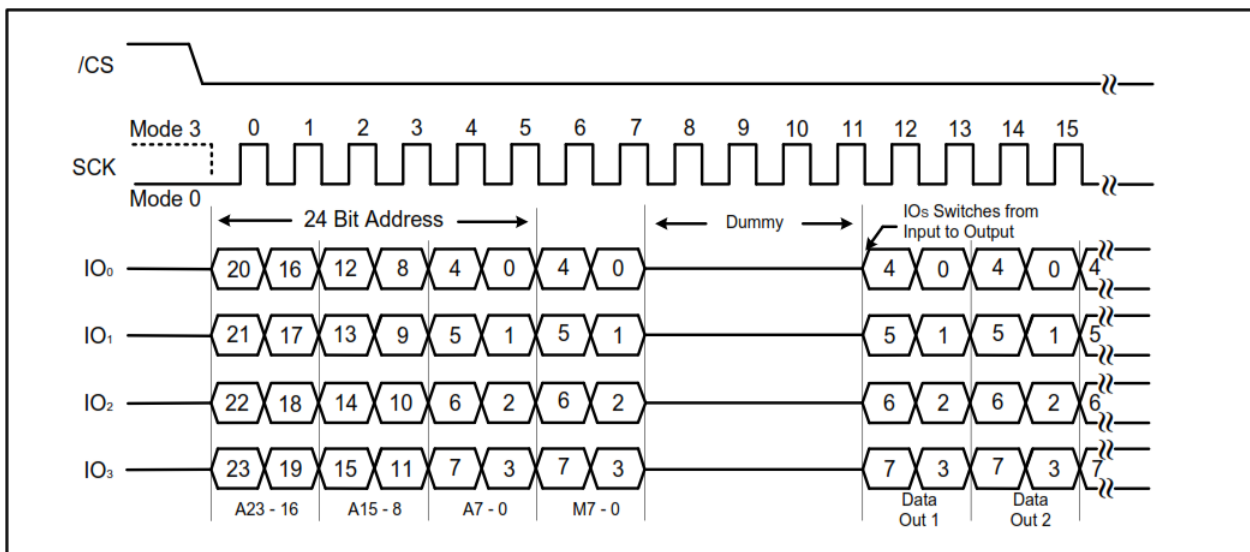

Figure 7-19. Fast Read Quad I/O Instruction (previous M7-0 = Axx, SPI mode)



Wrap Around in SPI mode

The Fast Read Quad I/O instruction can also be used to access specific portion within a page by issuing a “Set Burst with Wrap” (77h) instruction prior Fast Read Quad I/O (EBh) instruction. The “Set Burst with Wrap” (77h) instruction can either enable or disable the “Wrap Around” feature for the following Fast Read Quad I/O instruction.

When “Wrap Around” is enabled, the data being accessed can be limited to an 8/16/32/64-byte section of a 256-byte page. The output data starts at the initial address specified in the instruction, once it reaches the ending boundary of the 8/16/32/64-byte section, the output will wrap around to the beginning boundary automatically until \overline{CS} is pulled high to terminate the instruction.

The Burst with Wrap feature allows applications that use cache to quickly fetch a critical address and then fill the cache afterwards within a fixed length (8/16/32/64-byte) of data without issuing multiple read instructions. (Please refer to Section 7.31 Set Burst with Wrap).

Fast Read Quad I/O in QPI mode

When QPI mode is enabled, the number of dummy clocks is configured by the “Set Read Parameters (C0h)” instruction to accommodate a wide range of applications with different needs for either maximum Fast Read frequency or minimum data access latency. Depending on the Read Parameter Bits P [4] and P [5] setting, the number of dummy clocks can be configured as either 4 or 6 or 8. The default number of dummy clocks upon power up or after a Reset (99h) instruction is 4.

“Continuous Read Mode” feature is also available in QPI mode for Fast Read Quad I/O instruction. In QPI mode, the “Continuous Read Mode” bits M7-0 are also considered as dummy clocks. In the default setting, the data output will follow the Continuous Read Mode bits immediately.

“Wrap Around” feature is not available in QPI mode for Fast Read Quad I/O instruction. To perform a read operation with fixed data length wrap around in QPI mode, a “Burst Read with Wrap” (0Ch) instruction must be used. (Please refer to [Section 7.32 Burst Read with Wrap](#)).

Figure 7-20. Fast Read Quad I/O Instruction (Initial instruction or previous M7-0 ≠ A_{xh}, QPI mode, 80MHz)

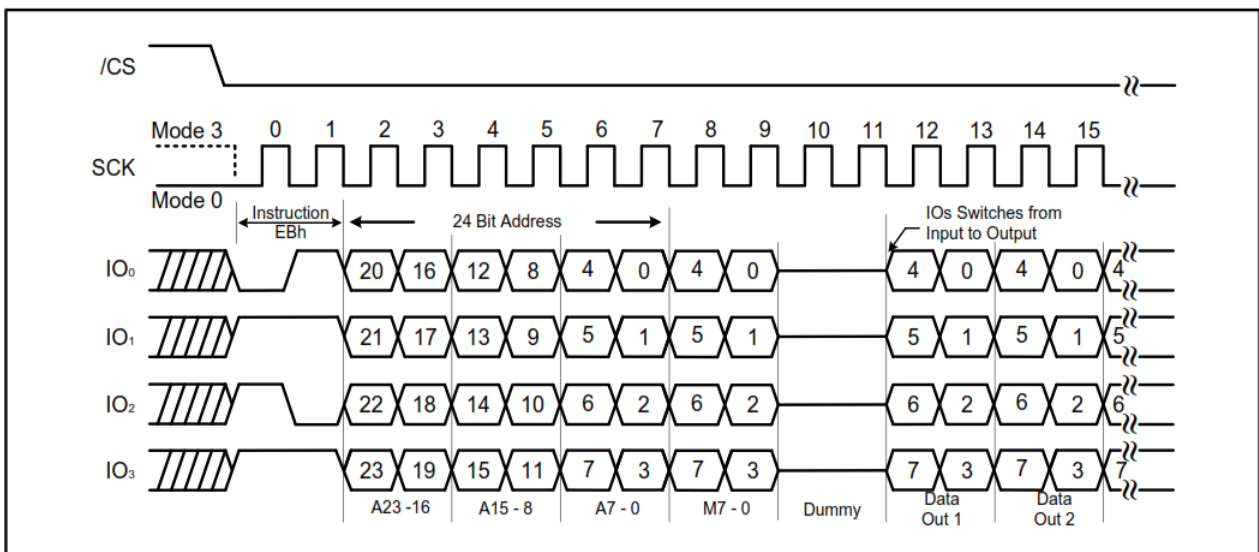
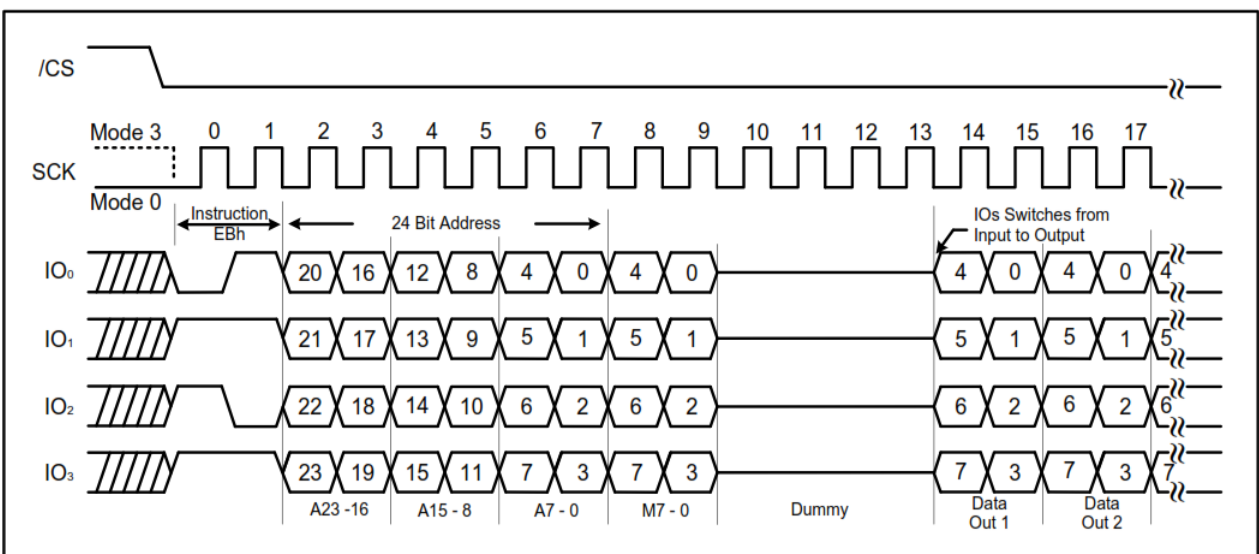

Figure 7-21. Fast Read Quad I/O Instruction (Initial instruction or previous M7-0 ≠ A_{xh}, QPI mode, 104MHz)



7.15 Page Program (02h)

The Page Program instruction is for programming the memory to be “0”. A Write Enable instruction must be issued before the device accept the Page Program Instruction (Status Register bit WEL=1). After the Write Enable (WREN) instruction has been decoded, the device sets the Write Enable Latch (WEL). The instruction is entered by driving the \overline{CS} pin low and then sending the instruction code “02h” with following a 24-bits address (A23-A0) and at least one data byte, into the SI pin. The \overline{CS} pin must be driven low for the entire time of the instruction while data is being sent to the device. (Please refer to Figure 7-22 and Figure 7-23).

If an entire 256 byte page is to be programmed, the last address byte (the 8 least significant address bits) should be set to 0. If the last address byte is not zero, and the number of clocks exceeds the remaining page length, the addressing will wrap to the beginning of the page. In some cases, less than 256 bytes (a partial page) can be programmed without having any effect on other bytes within the same page. One condition to perform a partial page program is that the number of clocks cannot exceed the remaining page length. If more than 256 bytes are sent to the device the addressing will wrap to the beginning of the page and overwrite previously sent data

The \overline{CS} pin must be driven high after the eighth bit of the last byte has been latched. If this is not done the Page Program instruction will not be executed. After \overline{CS} is driven high, the self-timed Page Program instruction will commence for a time duration of tPP (See AC Characteristics). While the Page Program cycle is in progress, the Read Status Register instruction may still be accessed for checking the status of the BUSY bit. The BUSY bit is a 1 during the Page Program cycle and becomes a 0 when the cycle is finished and the device is ready to accept other instructions again. When the BUSY bit is asserted, the Write Enable Latch (WEL) bit in the Status Register is cleared to 0.

Figure 7-22. Page Program Instruction (SPI Mode)

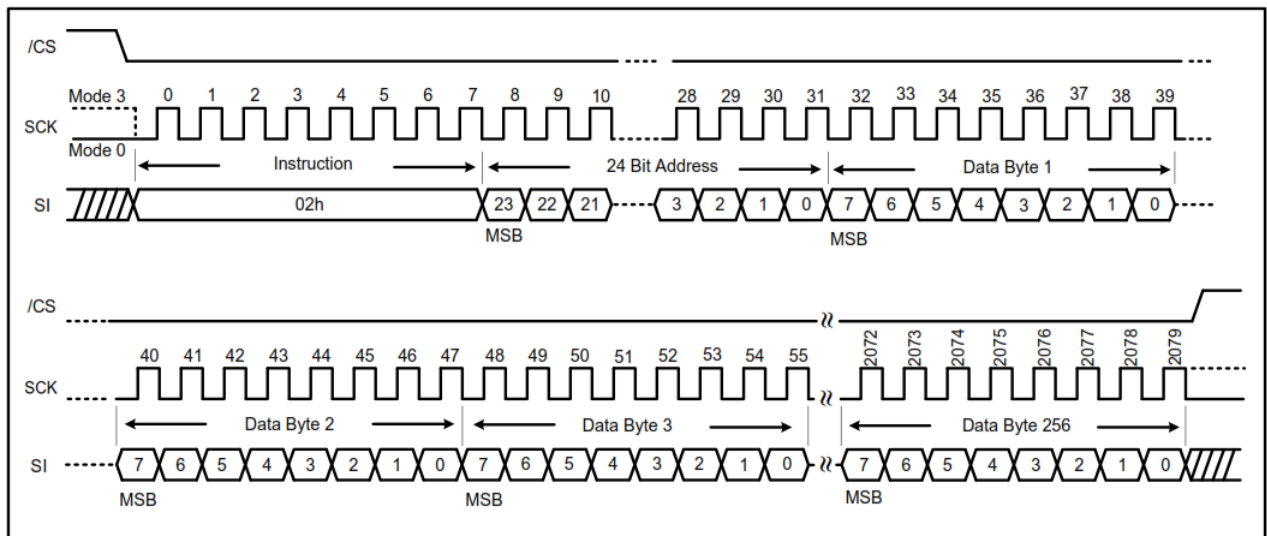
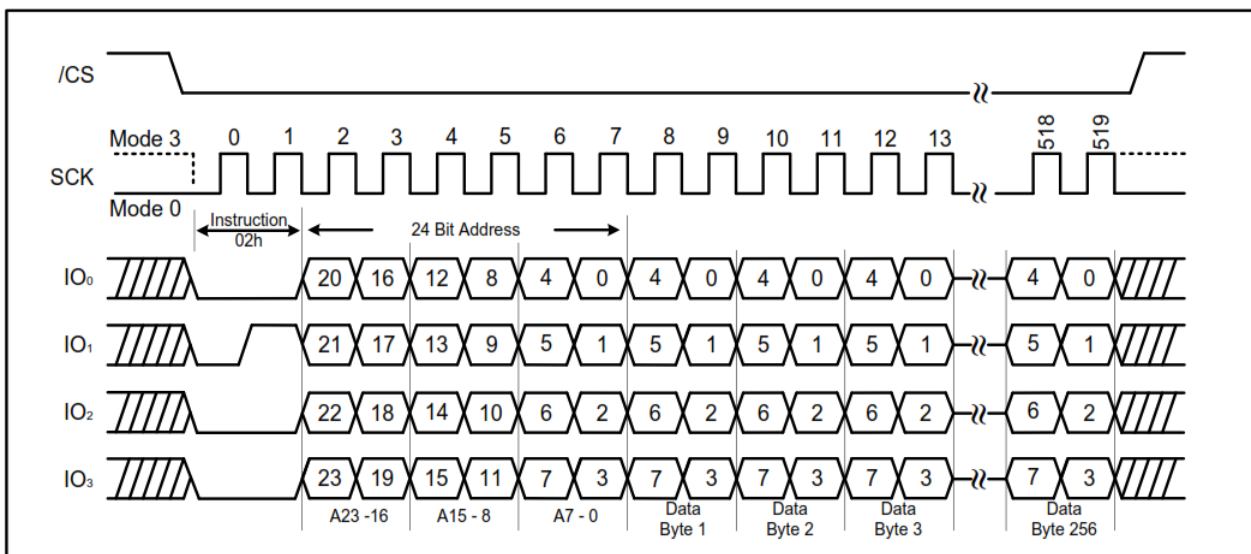

Figure 7-23. Page Program Instruction (QPI Mode)



7.16 Quad Page Program (33h)

The Quad Page Program instruction is to program the memory as being “0” at previously erased memory areas. The Quad Page Program takes four pins: IO₀, IO₁, IO₂ and IO₃ as address and data input, which can improve programmer performance and the effectiveness of application of lower clock less than 5MHz. System using faster clock speed will not get more benefit for the Quad Page Program as the required internal page program time is far more than the time data clock-in.

To use Quad Page Program, the Quad Enable bit must be set, A Write Enable instruction must be executed before the device will accept the Quad Page Program instruction (Status Register-1, WEL=1). The instruction is initiated by driving the $\overline{\text{CS}}$ pin low then sending the instruction code “33h” with following a 24-bit address (A₂₃-A₀) and at least one data, into the IO pins. The $\overline{\text{CS}}$ pin must be held low for the entire length of the instruction while data is being sent to the device. All other functions of Quad Page Program are perfectly same as standard Page Program. (Please refer to [Figure 7-24](#) and [Figure 7-25](#)).

Figure 7-24. Quad Page Program Instruction (SPI mode)

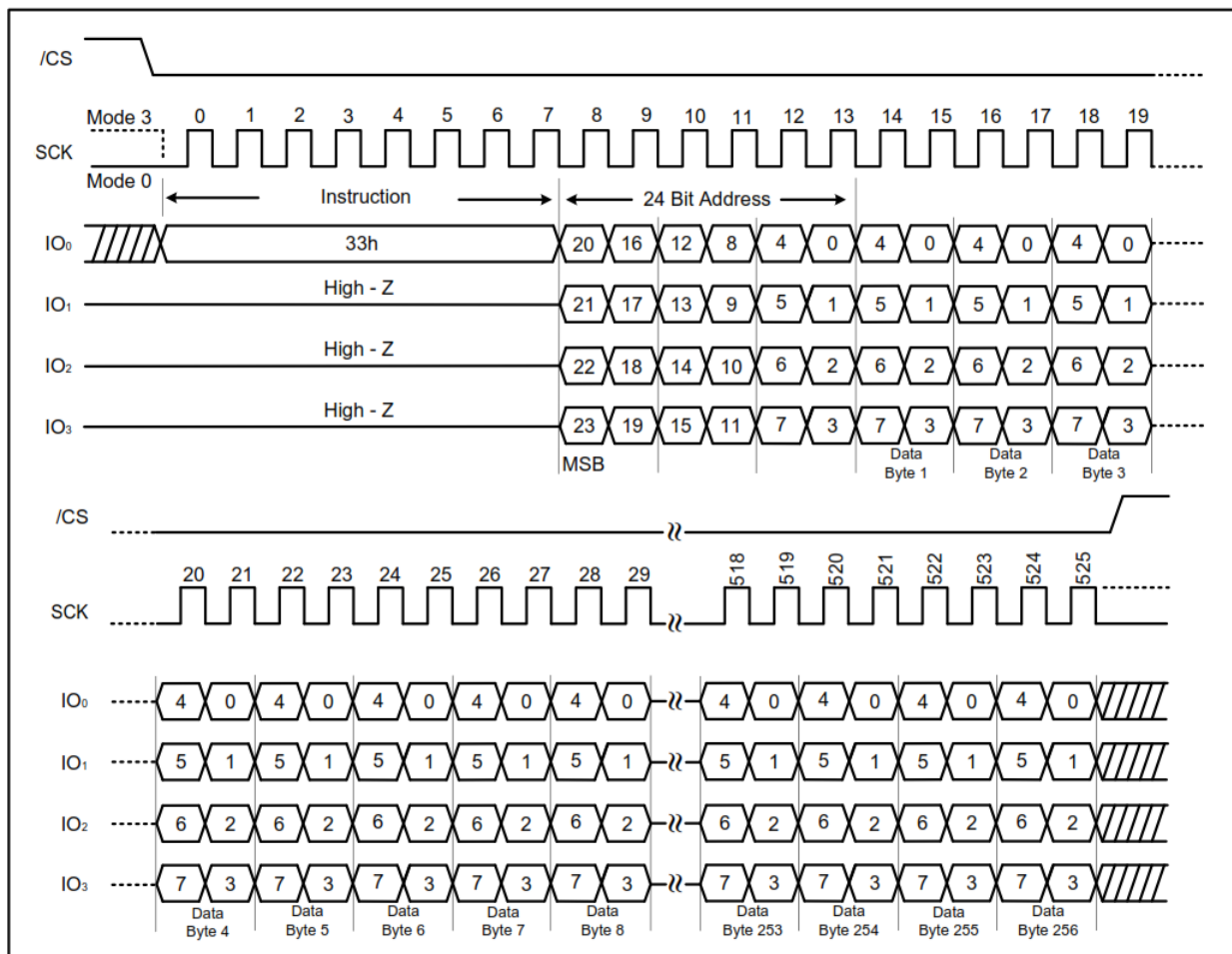
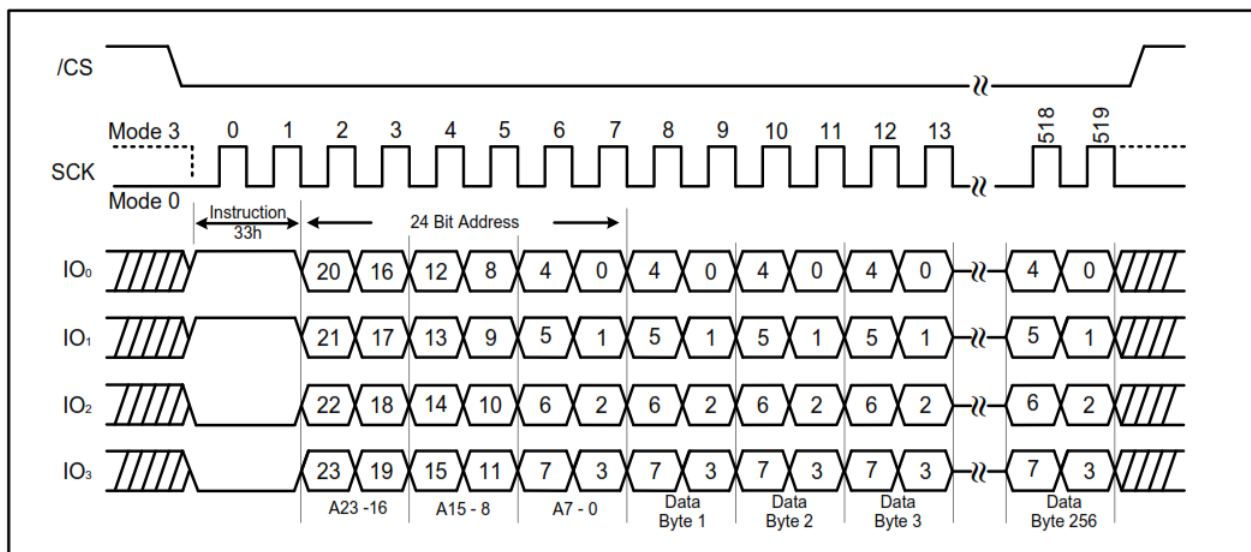

Figure 7-25. Quad Page Program Instruction (QPI mode)



7.17 Block Erase (20h)

The Block Erase instruction is to erase the data of the selected sector as being “1”. The instruction is used for 4K-byte Block. Prior to the Block Erase Instruction, the Write Enable instruction must be issued. The instruction is initiated by driving the \overline{CS} pin low and shifting the instruction code “20h” followed a 24-bit Block address (A23-A0). (Please refer to [Figure 7-26](#) and [Figure 7-27](#)). The \overline{CS} pin must go high after the eighth bit of the last byte has been latched in, otherwise, the Block Erase instruction will not be executed. After \overline{CS} goes high, the self-timed Block Erase instruction will commence for a time duration of tSE (See AC Characteristics).

While the Block Erase cycle is in progress, the Read Status Register instruction may still be accessed for checking the status of the BUSY bit. The BUSY bit is a 1 during the Block Erase cycle and becomes a 0 when the cycle is finished and the device is ready to accept other instructions again. When the BUSY bit is asserted, the Write Enable Latch (WEL) bit in the Status Register is cleared to 0.

Figure 7-26. Block Erase Instruction (SPI Mode)

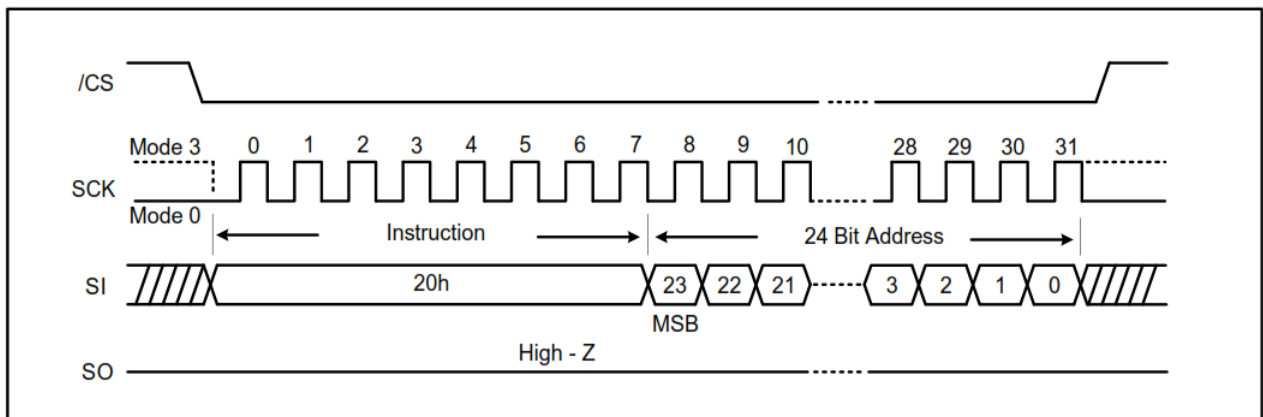
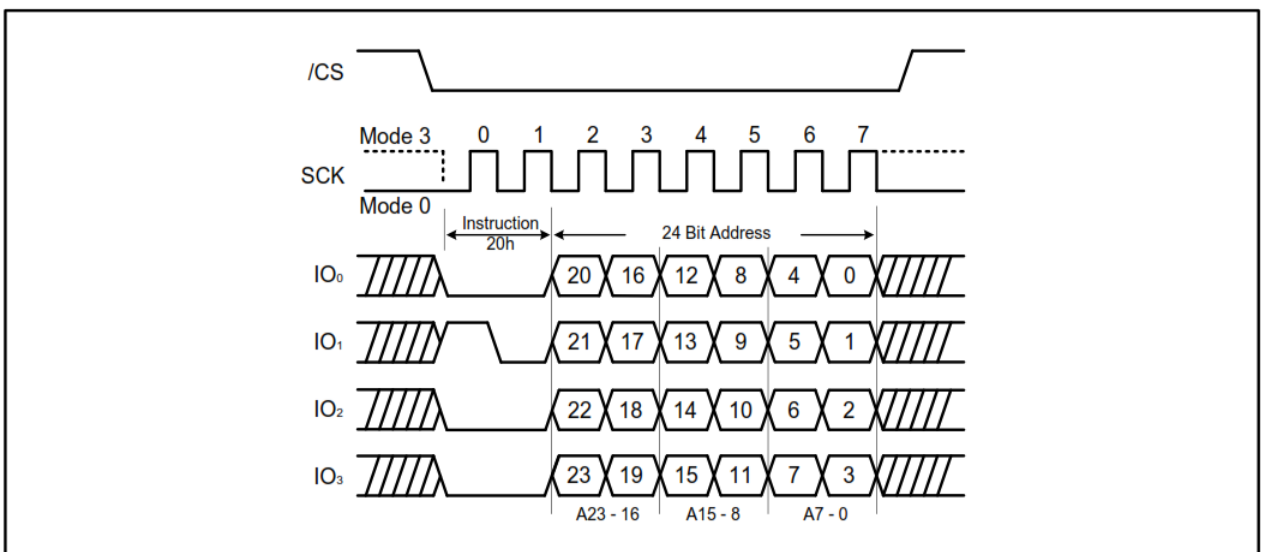

Figure 7-27. Block Erase Instruction (QPI Mode)



7.18 32KB Block Erase (52h)

The Block Erase instruction is to erase the data of the selected block as being “1”. The instruction is used for 32K-byte Block erase operation. Prior to the Block Erase Instruction, a Write Enable instruction must be issued. The instruction is initiated by driving the \overline{CS} pin low and shifting the instruction code “52h” followed a 24-bit block address (A23-A0). (Please refer to Figure 7-28 and Figure 7-29). The \overline{CS} pin must go high after the eighth bit of the last byte has been latched in, otherwise, the Block Erase instruction will not be executed. After \overline{CS} is driven high, the self-timed Block Erase instruction will commence for a time duration of tBE1 (See AC Characteristics).

While the Block Erase cycle is in progress, the Read Status Register instruction may still be read the status of the BUSY bit. The BUSY bit is a 1 during the Block Erase cycle and becomes a 0 when the cycle is finished and the device is ready to accept other instructions again. When the BUSY bit is asserted, the Write Enable Latch (WEL) bit in the Status Register is cleared to 0.

Figure 7-28. 32KB Block Erase Instruction (SPI Mode)

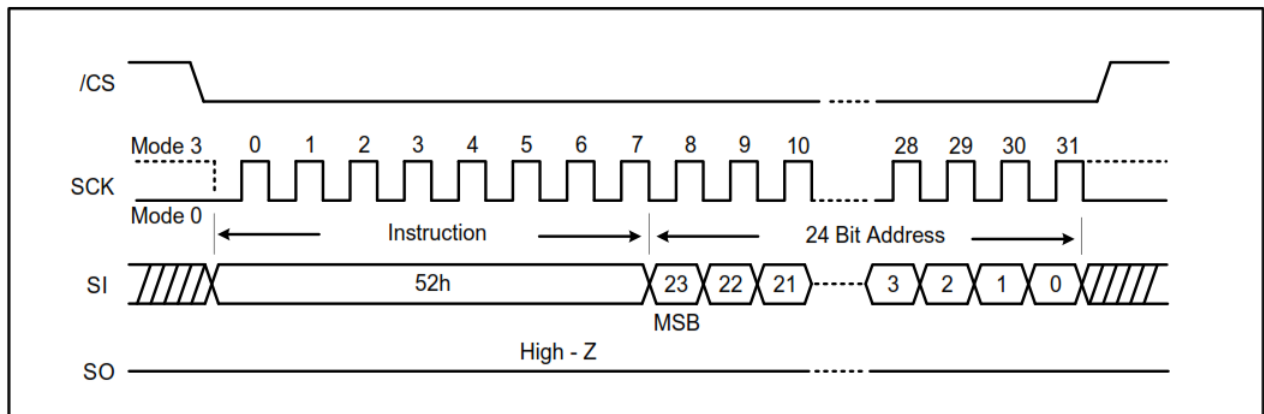
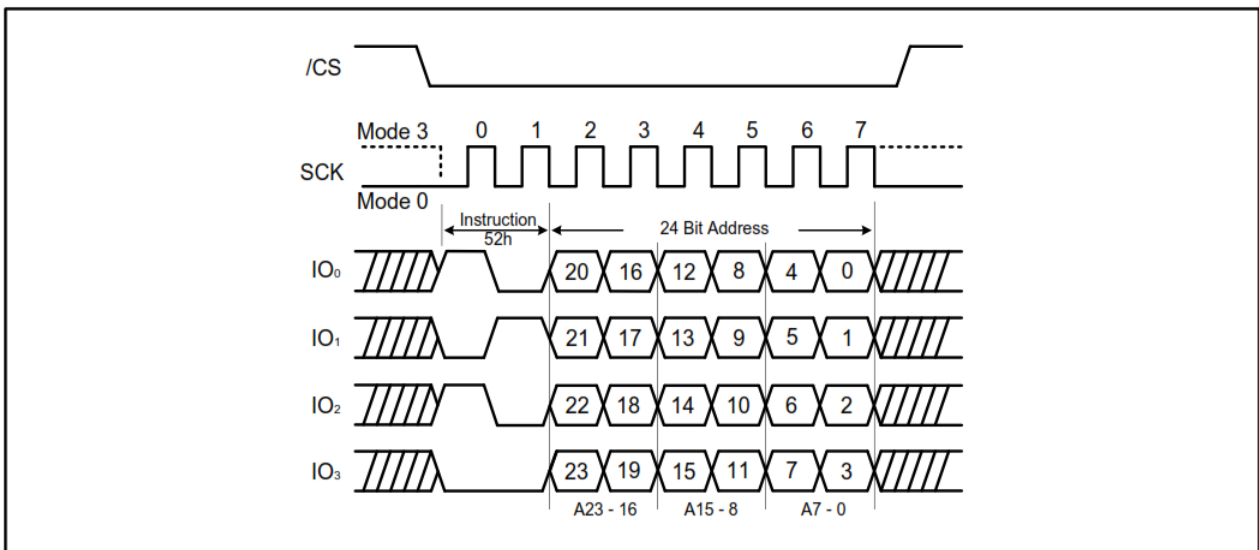

Figure 7-29. 32KB Block Erase Instruction (QPI Mode)



7.19 64KB Block Erase (D8h)

The Block Erase instruction is to erase the data of the selected block as being “1”. The instruction is used for 64K-byte Block erase operation. Prior to the Block Erase Instruction, a Write Enable instruction must be issued. The instruction is initiated by driving the \overline{CS} pin low and shifting the instruction code “D8h” followed a 24-bit block address (A23-A0). (Please refer to Figure 7-30 and Figure 7-31). The \overline{CS} pin must go high after the eighth bit of the last byte has been latched in, otherwise, the Block Erase instruction will not be executed. After \overline{CS} is driven high, the self-timed Block Erase instruction will commence for a time duration of tBE2 (See AC Characteristics).

While the Block Erase cycle is in progress, the Read Status Register instruction may still be read the status of the BUSY bit. The BUSY bit is a 1 during the Block Erase cycle and becomes a 0 when the cycle is finished and the device is ready to accept other instructions again. When the BUSY bit is asserted, the Write Enable Latch (WEL) bit in the Status Register is cleared to 0.

Figure 7-30. 64KB Block Erase Instruction (SPI Mode)

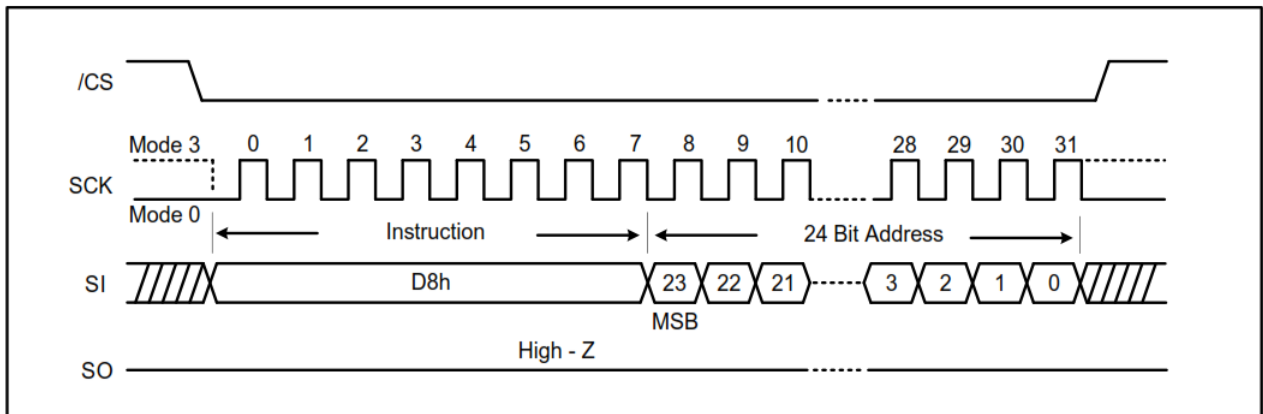
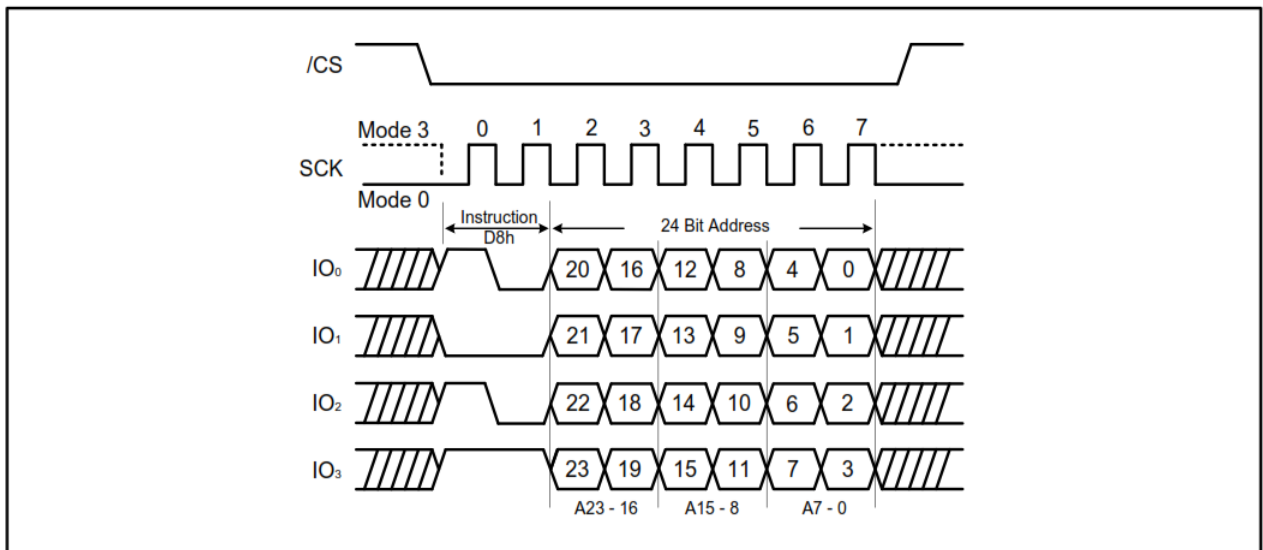

Figure 7-31. 64KB Block Erase Instruction (QPI Mode)



7.20 Chip Erase (C7h / 60h)

The Chip Erase instruction clears all bits in the device to be FFh (all 1s). Prior to the Chip Erase Instruction, a Write Enable instruction must be issued. The instruction is initiated by driving the \overline{CS} pin low and shifting the instruction code “C7h” or “60h”. (Please refer to Figure 7-32). The \overline{CS} pin must go high after the eighth bit of the last byte has been latched in, otherwise, the Chip Erase instruction will not be executed. After \overline{CS} is driven high, the self-timed Chip Erase instruction will commence for a duration of tCE (See AC Characteristics).

While the Chip Erase cycle is in progress, the Read Status Register instruction may still be accessed to check the status of the BUSY bit. The BUSY bit is a 1 during the Chip Erase cycle and becomes a 0 when the cycle is finished and the device is ready to accept other instructions again. When the BUSY bit is asserted, the Write Enable Latch (WEL) bit in the Status Register is cleared to 0.

Figure 7-32. Chip Erase Instruction for SPI Mode (left) and QPI Mode (right)

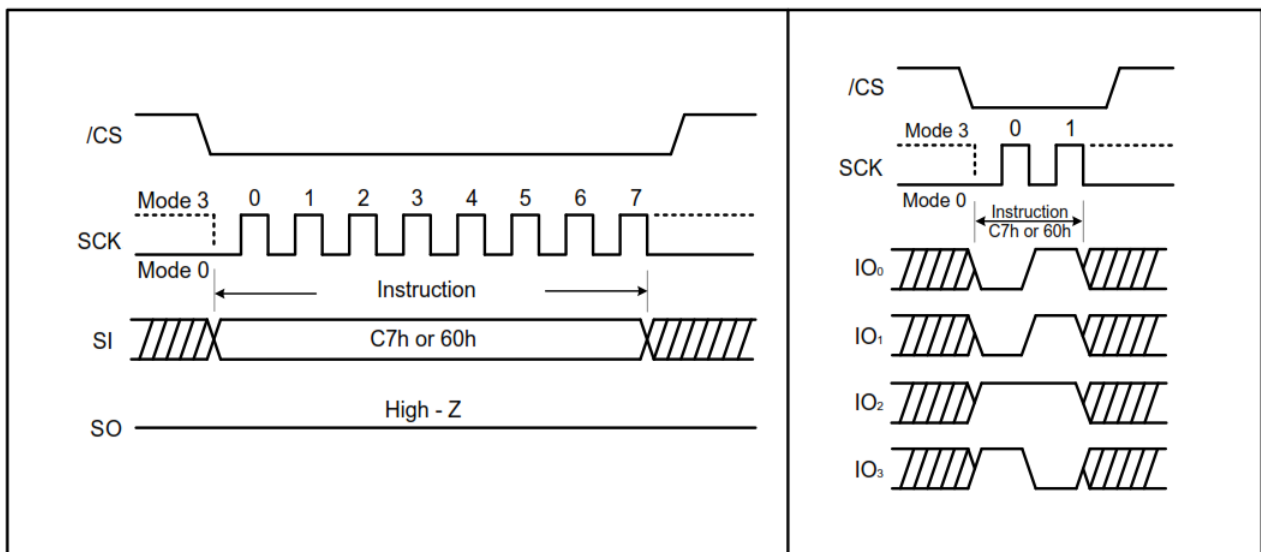

7.21 Erase / Program Suspend (75h)

The Erase/Program Suspend instruction allows the system to interrupt a Block Erase operation or a Page Program, Quad Data Input Page Program, Quad Page Program operation.

Erase Suspend is valid only during the Block erase operation. The Write Status Register-1 (01h), Write Status Register-2 (31h) instruction and Erase instructions (20h, 52h, D8h, C7h, 60h) are not allowed during Erase Suspend. During the Chip Erase operation, the Erase Suspend instruction is ignored.

Program Suspend is valid only during the Page Program, Quad Data Input Page Program or Quad Page Program operation. The Write Status Register-1(01h), Write Status Register-2 (31h) instruction, Program instructions (02h and 33h) and Erase Instructions (20h, 52h, D8h, C7h, 60h) are not allowed during Program Suspend.

The Erase/Program Suspend instruction “75h” will be accepted by the device only if the SUS bit in the Status Register equals to 0 and the BUSY bit equals to 1 while a Block Erase or a Page Program operation is on-going. If the SUS bit equals to 1 or the BUSY bit equals to 0, the Suspend instruction will be ignored by the device. A maximum of time of “tSUS” (See AC Characteristics) is required to suspend the erase or program operation. After Erase/Program Suspend, the SUS bit in the Status Register will be set from 0 to 1 immediately and The BUSY bit in the Status Register will be cleared from 1 to 0 within “tSUS”. For a previously resumed Erase/Program operation, it is also required that the Suspend instruction “75h” is not issued earlier than a minimum of time of “tSUS” following the preceding Resume instruction “7Ah”.

Unexpected power off during the Erase/Program suspend state will reset the device and release the suspend state. SUS bit in the Status Register will also reset to 0. The data within the page or block that was being suspended may become corrupted. It is recommended for the user to implement system design techniques against the accidental power interruption and preserve data integrity during erase/program suspend state. (Please refer to Figure 7-33 and Figure 7-34).

Figure 7-33. Erase Suspend instruction (SPI Mode)

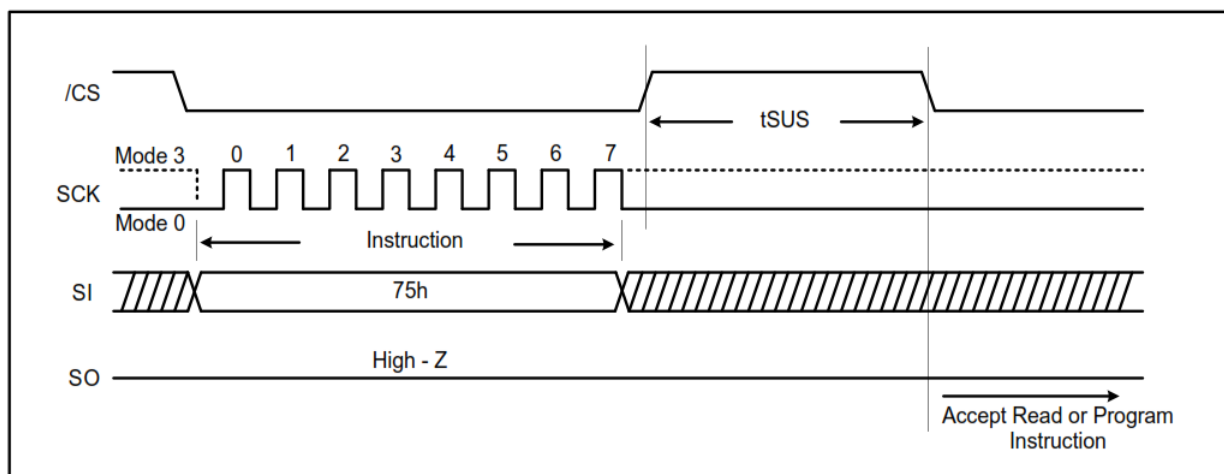
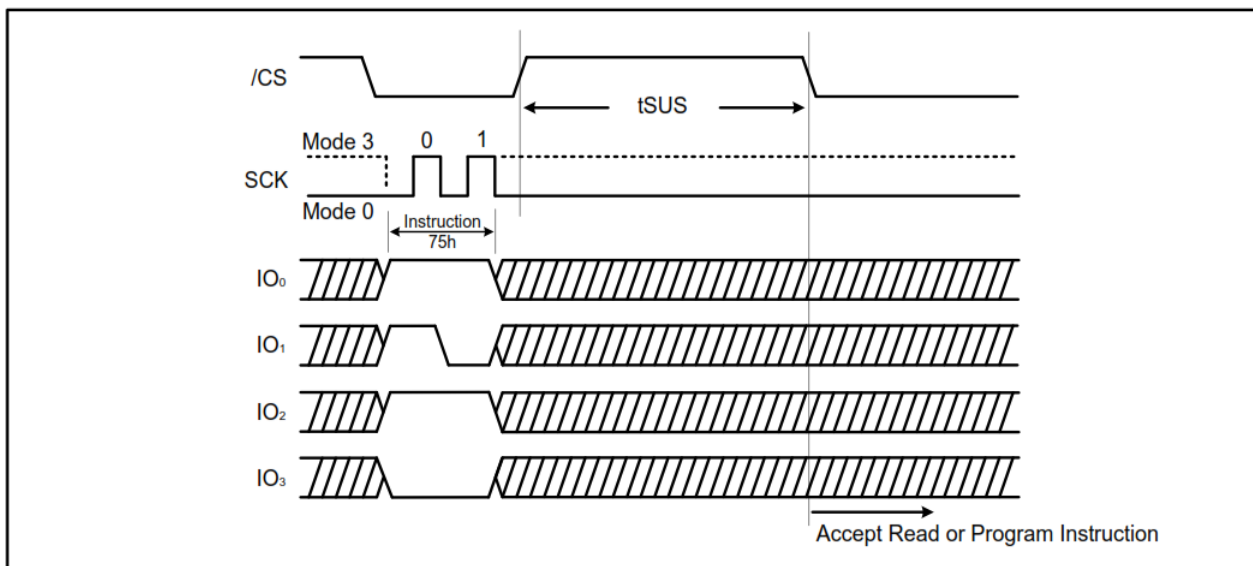

Figure 7-34. Erase Suspend instruction (QPI Mode)



7.22 Erase / Program Resume (7Ah)

The Erase/Program Resume instruction "7Ah" is to restart the Block Erase operation or the Page Program operation upon an Erase/Program Suspend. The Resume instruction "7Ah" will be accepted by the device only if the SUS bit in the Status Register equals to 1 and the BUSY bit equals to 0. After issued, the SUS bit will be cleared from 1 to 0 immediately, the BUSY bit will be set from 0 to 1 within 200ns and the Block will complete the erase operation or the page will complete the program operation. If the SUS bit equals to 0 or the BUSY bit equals to 1, the Resume instruction "7Ah" will be ignored by the device.

Resume instruction cannot be accepted if the previous Erase/Program Suspend operation was interrupted by unexpected power off. It is also required that a subsequent Erase/Program Suspend instruction not to be issued within a minimum of time of “tSUS” following a previous Resume instruction. (Please refer to [Figure 7-35](#) and [Figure 7-36](#)).

Figure 7-35. Erase / Program Resume instruction (SPI Mode)

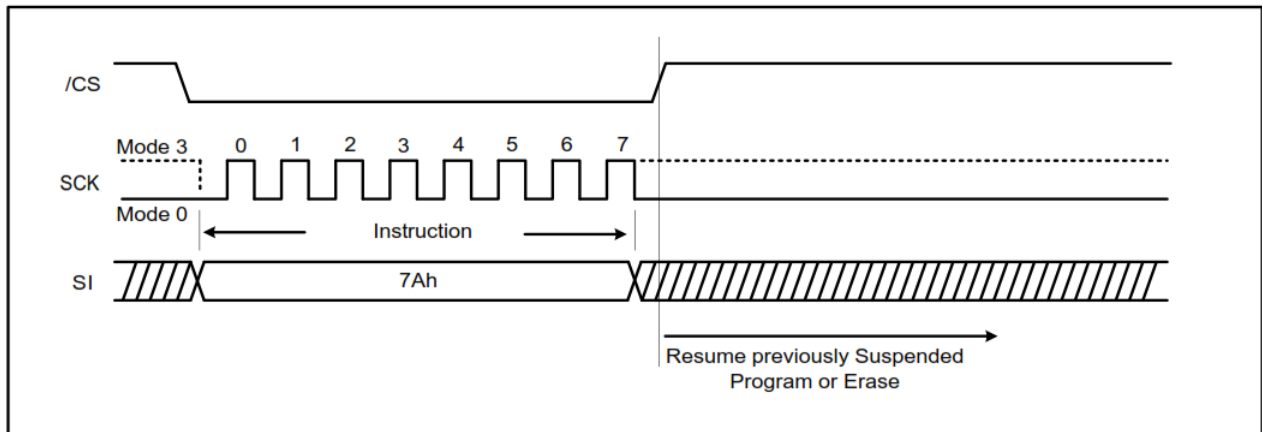
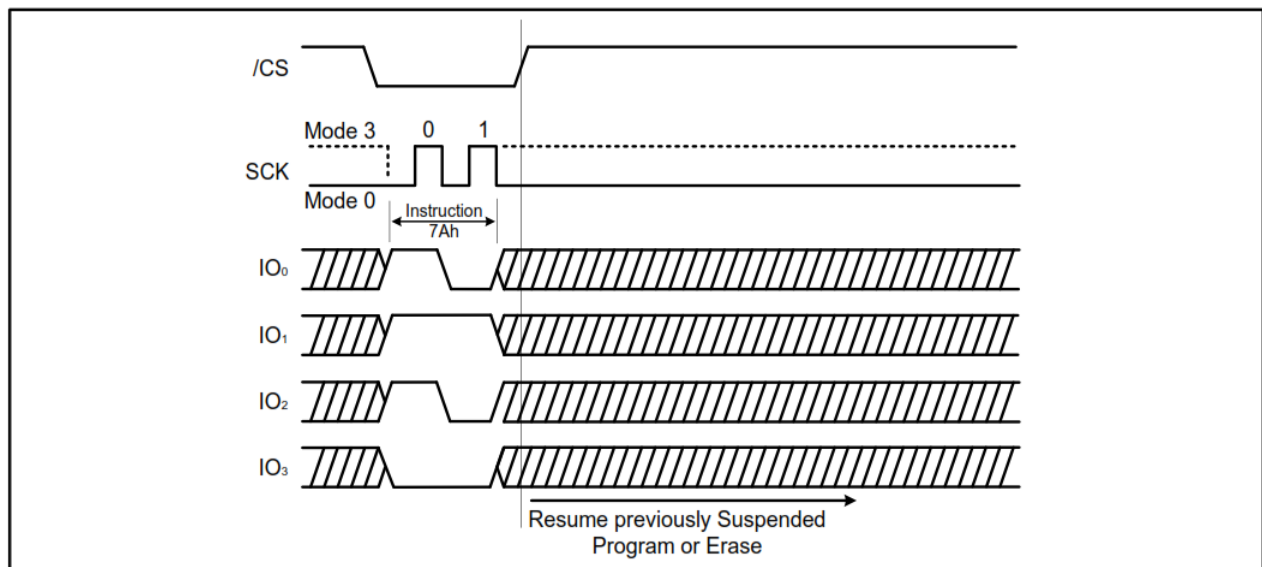

Figure 7-36. Erase / Program Resume instruction (QPI Mode)



7.23 Deep Power Down (B9h)

Executing the Deep Power Down instruction is the best way to put the device in the lowest power consumption. The Deep Power Down instruction reduces the standby current (from ICC1 to ICC2, as specified in AC characteristics). The instruction is entered by driving the \overline{CS} pin low with following the instruction code “B9h”. (Please refer to [Figure 7-37](#) and [Figure 7-38](#)).

The \overline{CS} pin must go high exactly at the byte boundary (the latest eighth bit of instruction code been latched-in); otherwise, the Deep Power Down instruction is not executed. After \overline{CS} goes high, it requires a delay of tDP and the Deep Power Down mode is entered. While in the Release Deep Power Down / Device ID instruction, which restores the device to normal operation, will be recognized. All other instructions are ignored including the Read Status Register instruction, which is always available during normal operation. Deep Power Down Mode automatically stops at Power-Down, and the device always Power-up in the Standby Mode.

Figure 7-37. Deep Power Down Instruction (SPI Mode)

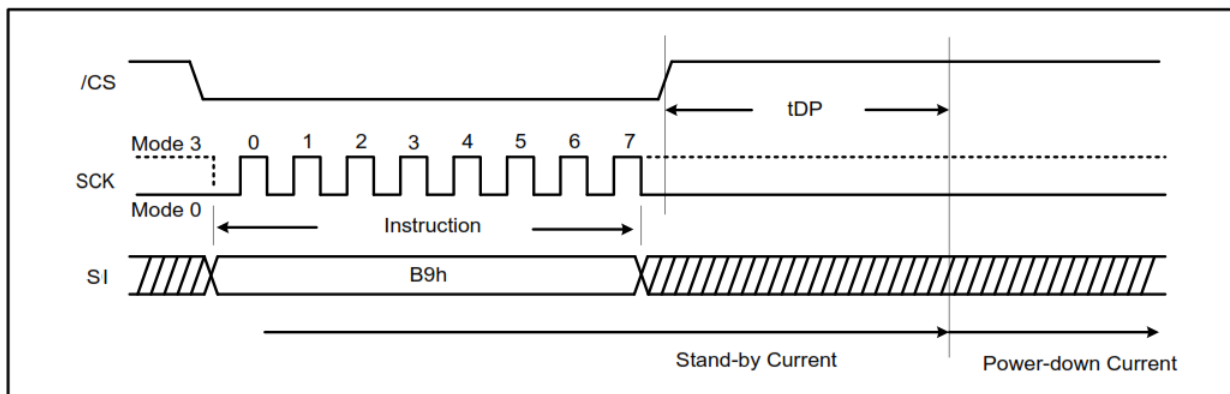
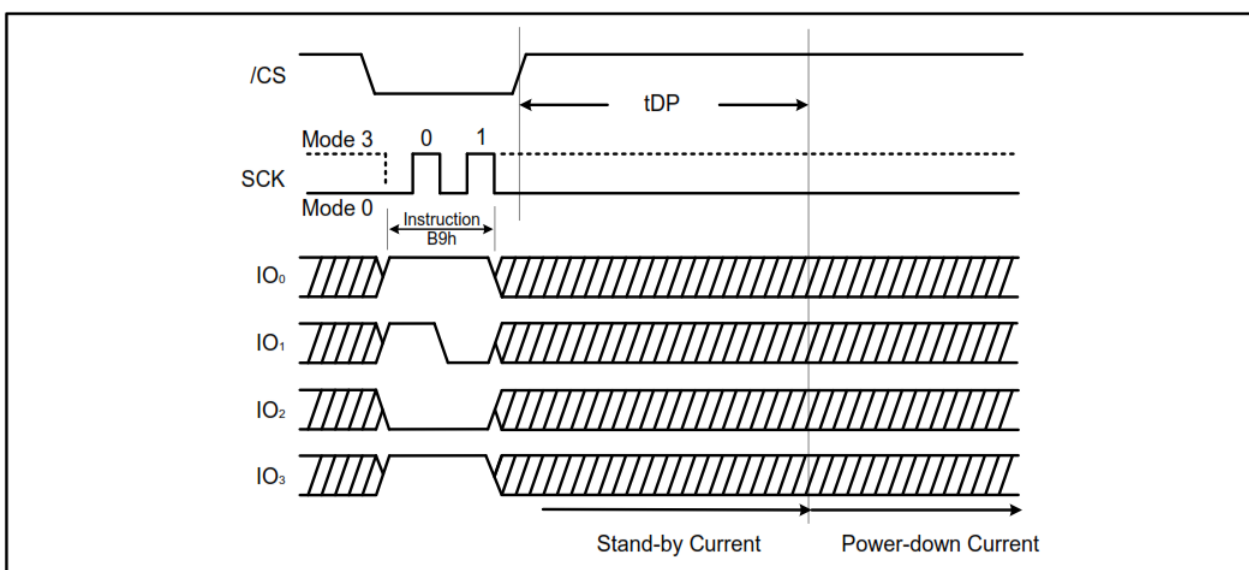

Figure 7-38. Deep Power Down Instruction (QPI Mode)



7.24 Release Deep Power Down / Device ID (ABh)

The Release Deep Power Down / Device ID instruction is a multi-purpose instruction. It can be used to release the device from the Deep Power Down state or obtain the device identification (ID).

The instruction is issued by driving the $\overline{\text{CS}}$ pin low, sending the instruction code “ABh” and driving $\overline{\text{CS}}$ high as shown in figure [Figure 7-39](#) and [Figure 7-40](#). Release from Deep Power Down require the time duration of tRES1 (See AC Characteristics) for re-work a normal operation and accepting other instructions. The $\overline{\text{CS}}$ pin must keep high during the tRES1 time duration.

The Device ID can be read during SPI mode only. In other words, Device ID feature is not available in QPI mode for Release Deep Power Down/Device ID instruction. To obtain the Device ID in SPI mode, instruction is initiated by driving the $\overline{\text{CS}}$ pin low and sending the instruction code “ABh” with following 3-dummy bytes. The Device ID bits are then shifted on the falling edge of SCK with most significant bit (MSB) first as shown in [Figure 7-41](#). After $\overline{\text{CS}}$ is driven high it must keep high for a time duration of tRES2 (See AC Characteristics). The Device ID can be read continuously. The instruction is completed by driving $\overline{\text{CS}}$ high.

If the Release from Deep Power Down /Device ID instruction is issued while an Erase, Program or Write cycle is in process (when BUSY equals 1) the instruction is ignored and will not have any effects on the current cycle.

Figure 7-39. Release Power Down Instruction (SPI Mode)

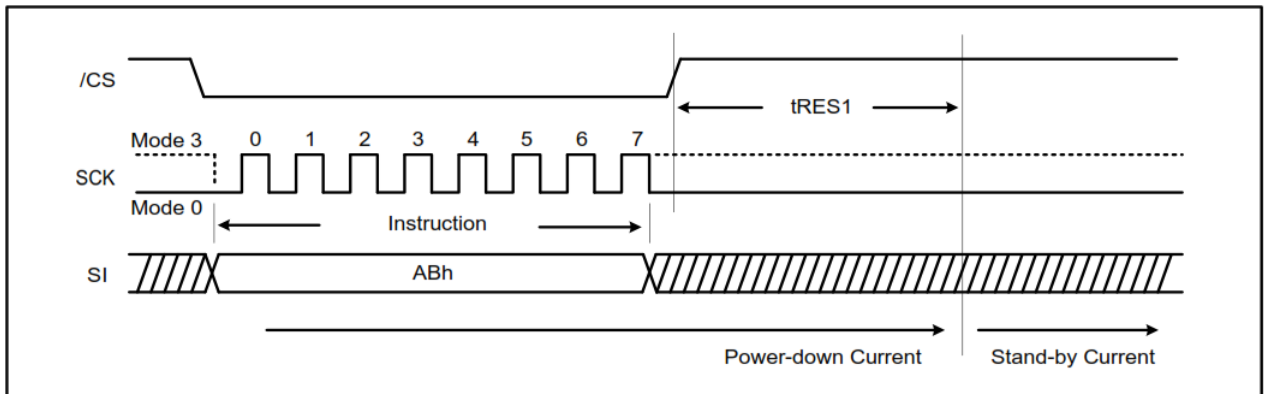

Figure 7-40. Release Power Down Instruction (QPI Mode)

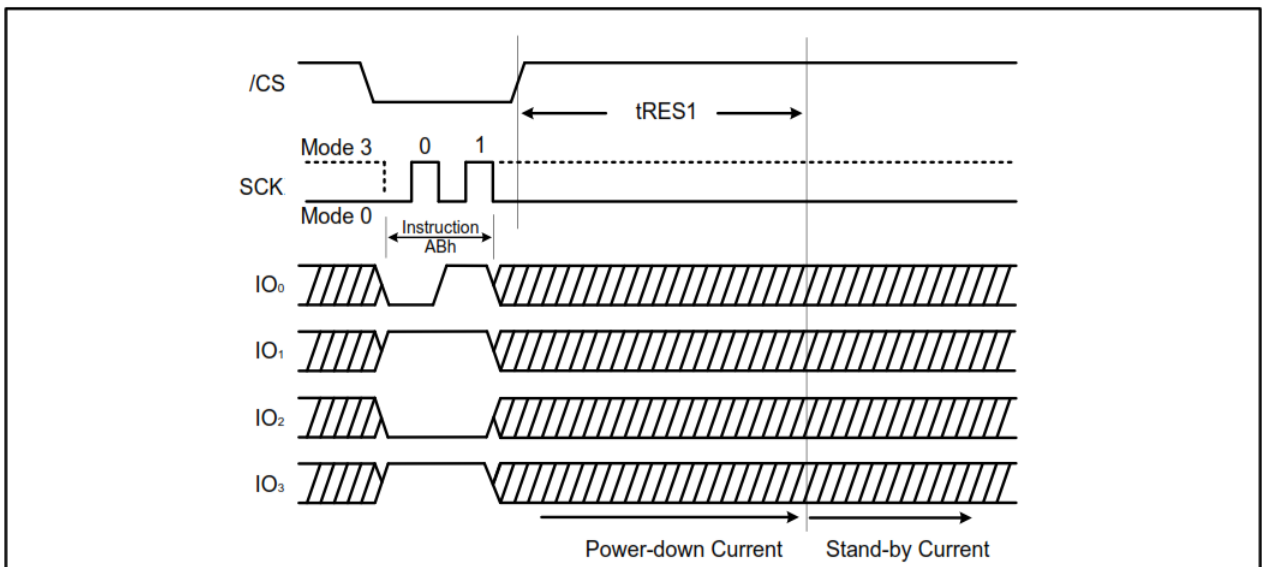
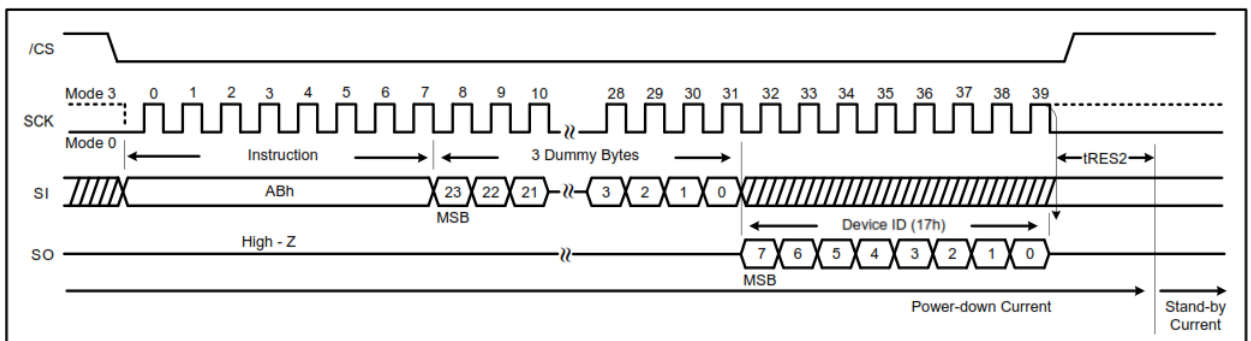

Figure 7-41. Release Power Down / Device ID Instruction (SPI Mode)



7.25 Read Manufacturer / Device ID Dual I/O (90h)

The Read Manufacturer/ Device ID Dual I/O instruction provides both the JEDEC assigned manufacturer ID and the specific device ID.

The Read Manufacturer/ Device ID instruction is very similar to the Fast Read Dual I/O instruction. The instruction is initiated by driving the \overline{CS} pin low and shifting the instruction code “90h” followed by a 24-bit address (A23-A0) of 000000h. After which, the Manufacturer ID for Adesto (1Fh) and the Device ID (15h) are shifted out on the falling edge of SCK with most significant bit (MSB) first as shown in Figure 7-42 and Figure 7-43. If the 24-bit address is initially set to 000001h the Device ID will be read first and then followed by the Manufacturer ID. The Manufacturer and Device ID can be read continuously, alternating from one to the other. The instruction is completed by driving \overline{CS} high.

Figure 7-42. Read Manufacturer/ Device ID instruction (SPI Mode)

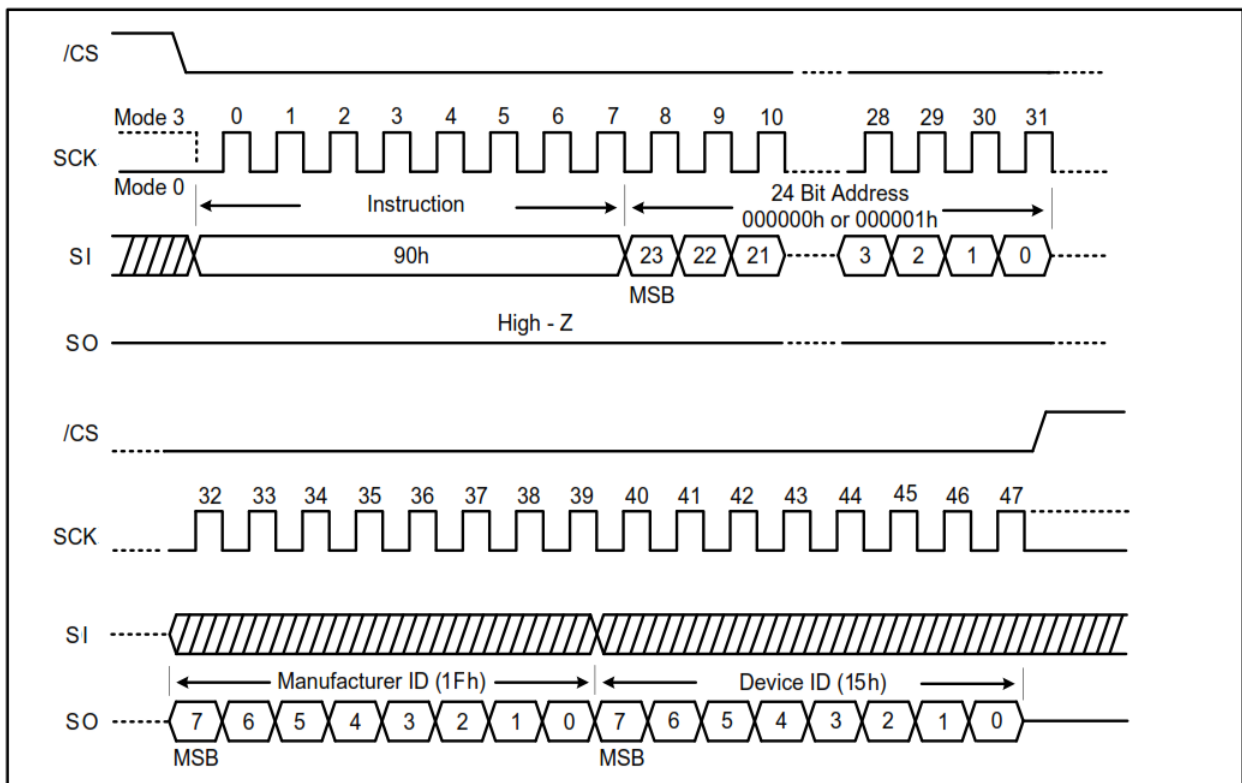
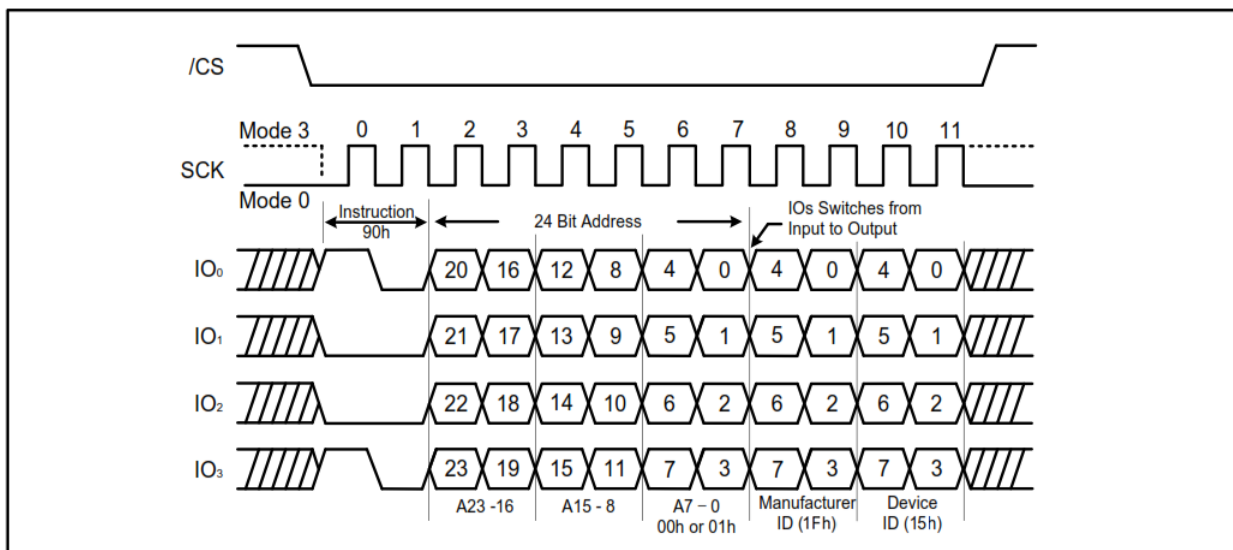

Figure 7-43. Read Manufacturer/ Device ID instruction (QPI Mode)



7.26 Read Manufacturer / Device ID Dual I/O (92h)

The Read Manufacturer/ Device ID Dual I/O instruction provides both the JEDEC assigned manufacturer ID and the specific device ID.

The Read Manufacturer/ Device ID instruction is very similar to the Fast Read Dual I/O instruction. The instruction is initiated by driving the \overline{CS} pin low and shifting the instruction code “92h” followed by a 24-bit address (A23-A0) of 000000h. After which, the Manufacturer ID for Adesto (1Fh) and the Device ID(15h) are shifted out on the falling edge of SCK with most significant bit (MSB) first as shown in Figure 7-44. If the 24-bit address is initially set to 000001h the Device ID will be read first and then followed by the Manufacturer ID. The Manufacturer and Device ID can be read continuously, alternating from one to the other. The instruction is completed by driving \overline{CS} high.

Figure 7-44. Read Dual Manufacturer/ Device ID Dual I/O instruction (SPI Mode)

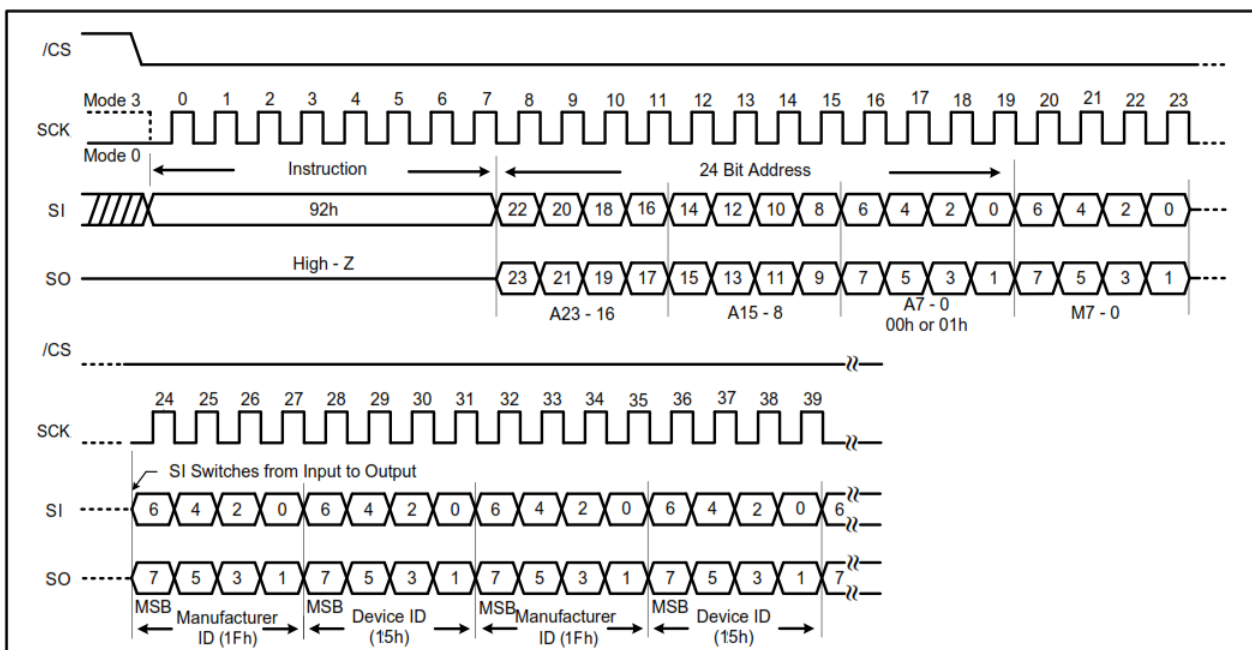

7.27 Read Manufacturer / Device ID Quad I/O (94h)

The Read Manufacturer/ Device ID Quad I/O instruction provides both the JEDEC assigned manufacturer ID and the specific device ID.

The Read Manufacturer/ Device ID instruction is very similar to the Fast Read Quad I/O instruction. The instruction is initiated by driving the \overline{CS} pin low and shifting the instruction code “94h” followed by a 24-bit address (A23-A0) of 000000h. After which, the Manufacturer ID for Adesto (1Fh) and the Device ID(15h) are shifted out on the falling edge of SCK with most significant bit (MSB) first as shown in Figure 7-45. If the 24-bit address is initially set to 000001h the Device ID will be read first and then followed by the Manufacturer ID. The Manufacturer and Device ID can be read continuously, alternating from one to the other. The instruction is completed by driving \overline{CS} high.

Figure 7-45. Read Quad Manufacturer/ Device ID Quad I/O instruction (SPI Mode)

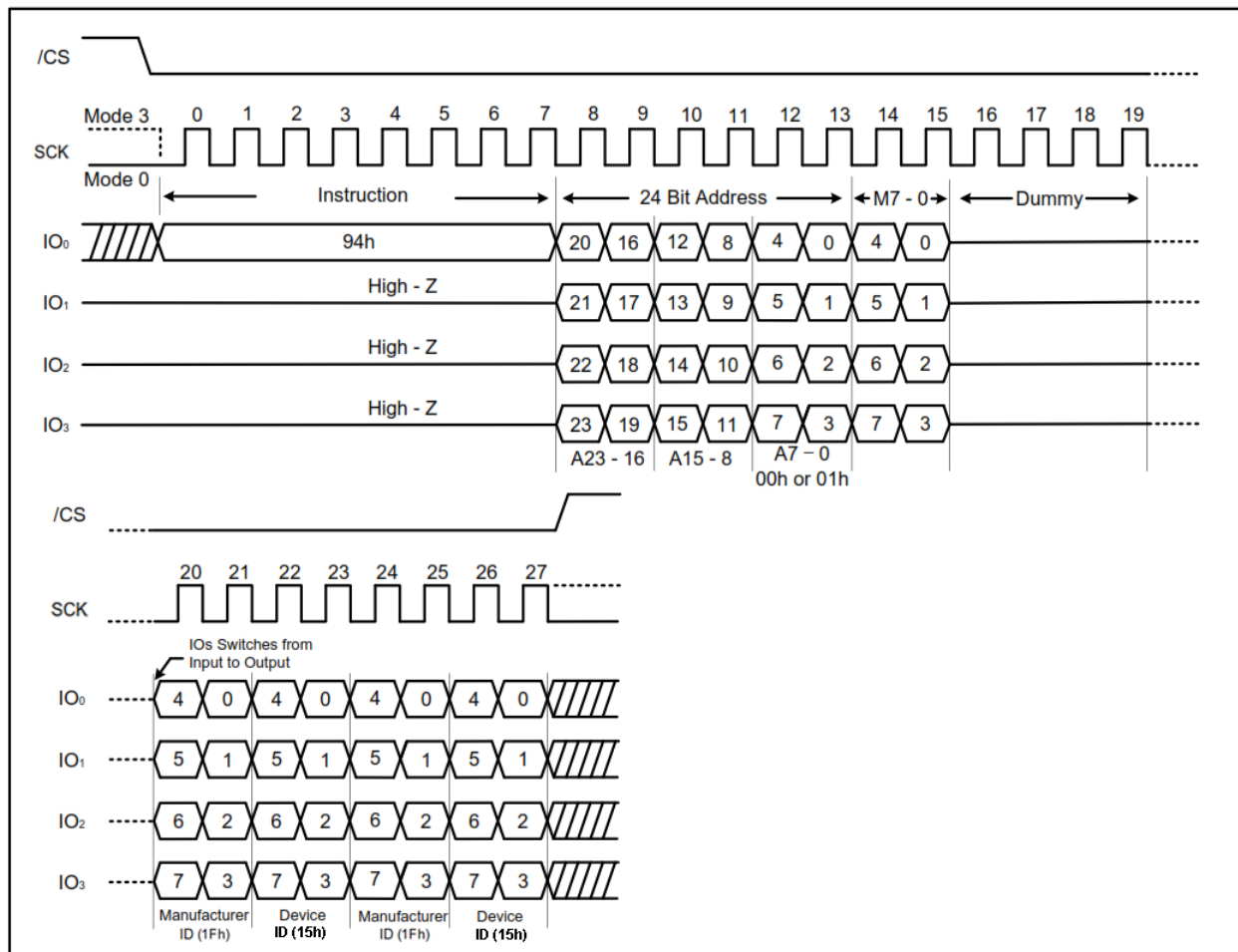

JEDEC ID (9Fh)

For compatibility reasons, the AT25SL321 provides several instructions to electronically determine the identity of the device. The Read JEDEC ID instruction is congruous with the JEDEC standard for SPI compatible serial flash memories that was adopted in 2003. The instruction is entered by driving the \overline{CS} pin low with following the instruction code “9Fh”. JEDEC assigned Manufacturer ID byte for Adesto (1Fh) and two Device ID bytes, Memory Type (ID15-ID8) and Capacity (ID7-ID0) are then shifted out on the falling edge of SCK with most significant bit (MSB) first shown in Figure 7-46 and Figure 7-47. For memory type and capacity values refer to Manufacturer and Device Identification table. The JEDEC ID can be read continuously. The instruction is terminated by driving \overline{CS} high.

Figure 7-46. Read JEDEC ID instruction (SPI Mode)

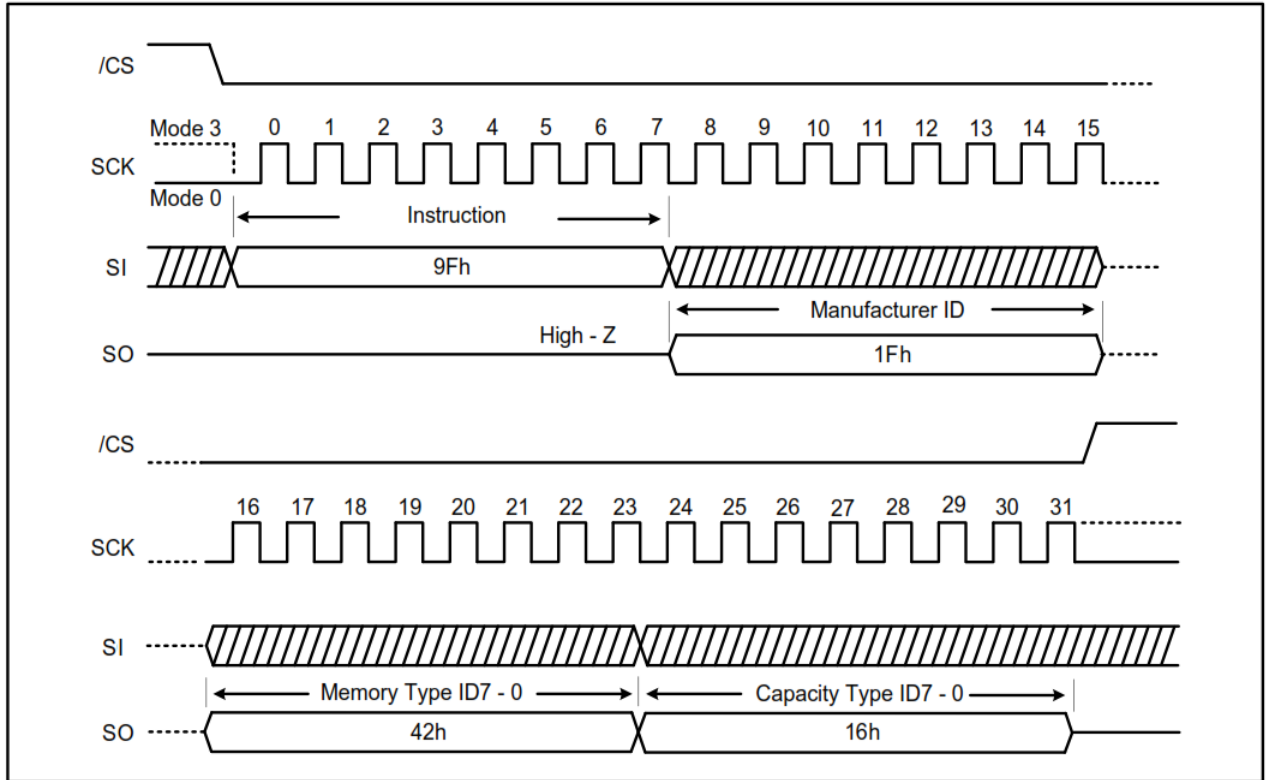
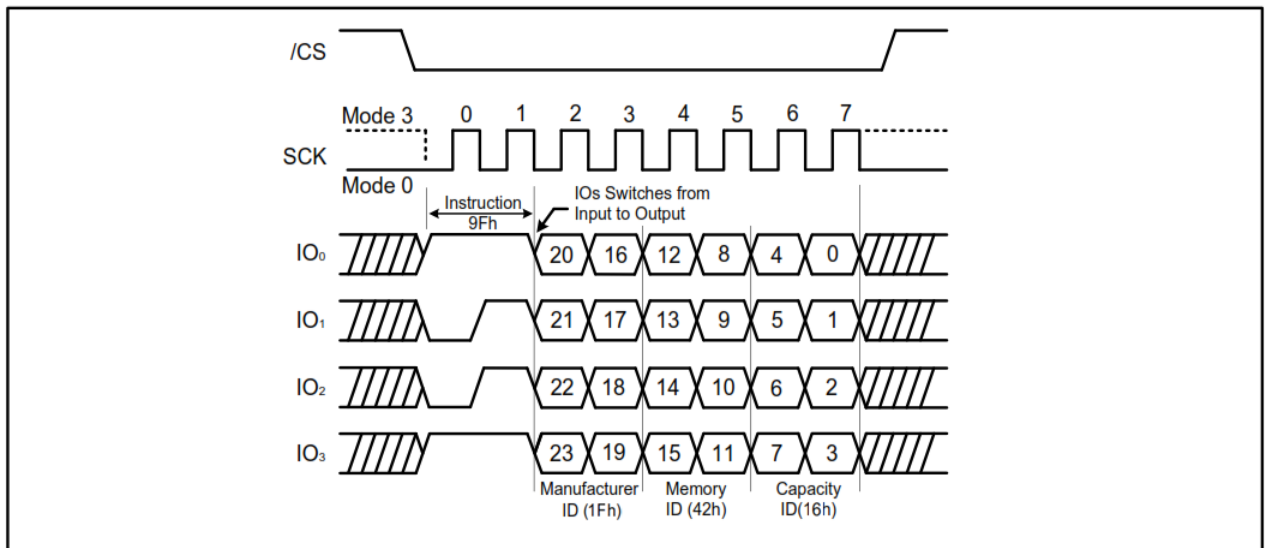

Figure 7-47. Read JEDEC ID instruction (QPI Mode)



7.28 Enable QPI (38h)

The AT25SL321 support both Standard/Dual/Quad Serial Peripheral interface (SPI) and Quad Peripheral Interface (QPI). However, SPI mode and QPI mode cannot be used at the same time. Enable QPI instruction is the only way to switch the device from SPI mode to QPI mode.

In order to switch the device to QPI mode, the Quad Enable (QE) bit in Status Register 2 must be set to 1 first, and an Enable QPI instruction must be issued. If the Quad Enable (QE) bit is 0, the Enable QPI instruction will be ignored and the device will remain in SPI mode.

After power-up, the default state of the device is SPI mode. See the instruction Set [Table 7.1](#) for all the commands supported in SPI mode and the instruction Set [Table 7-5](#) for all the instructions supported in QPI mode.

When the device is switched from SPI mode to QPI mode, the existing Write Enable and Program/Erase Suspend status, and the Wrap Length setting will remain unchanged.

Figure 7-48. Enable QPI instruction (SPI Mode only)

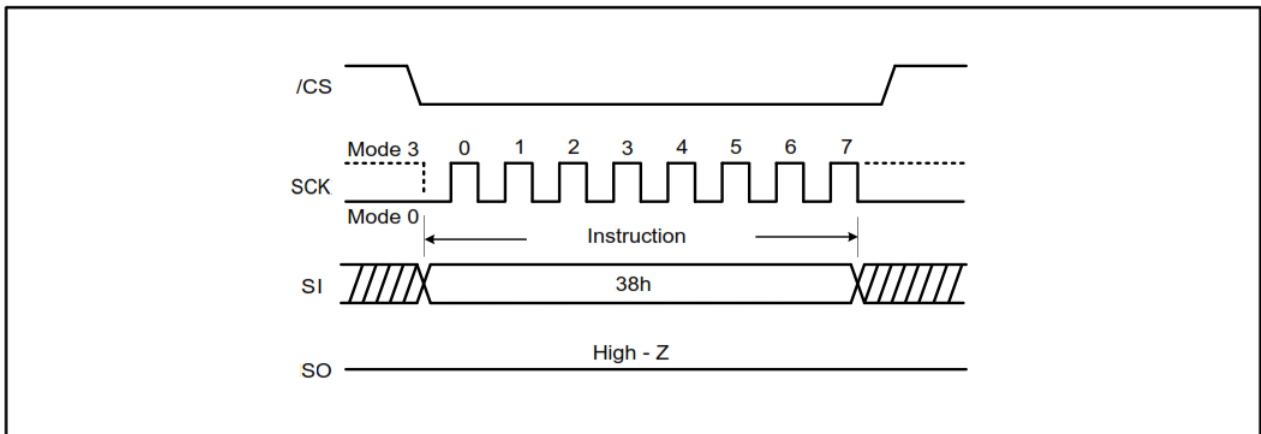

7.29 Disable QPI (FFh)

By issuing Disable QPI (FFh) instruction, the device is reset SPI mode. When the device is switched from QPI mode to SPI mode, the existing Write Enable Latch (WEL) and Program/Erase Suspend status, and the Wrap Length setting will remain unchanged.

Figure 7-49. Disable QPI instruction for QPI mode

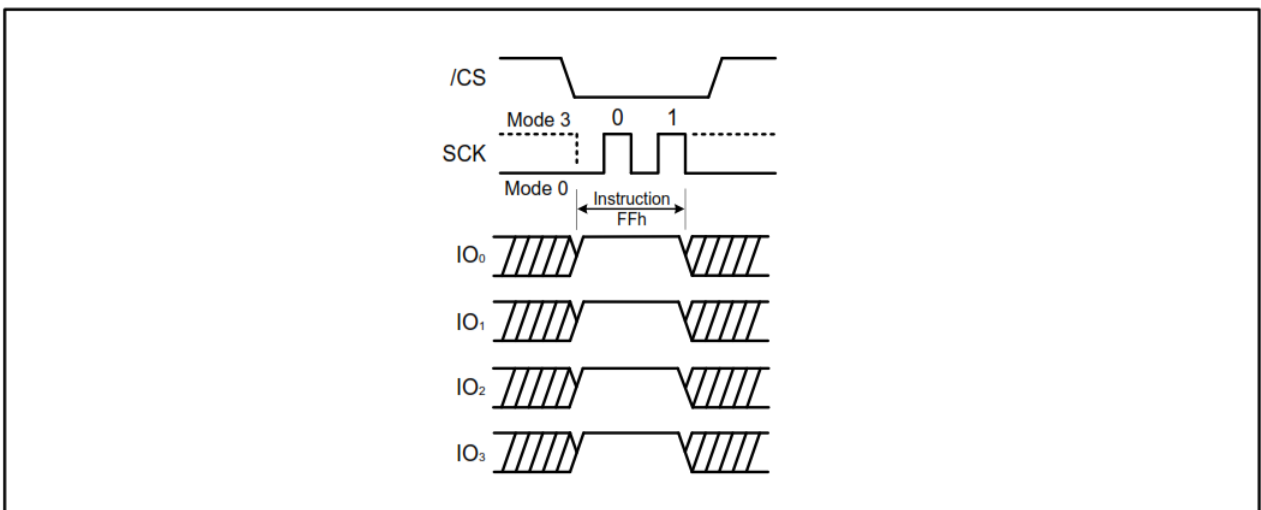

7.30 Word Read Quad I/O (E7h)

The Quad I/O dramatically reduces instruction overhead allowing faster random access for code execution (XIP) directly from the Quad SPI. The Quad Enable bit (QE) of Status Register-2 must be set to enable the Word Read Quad I/O instruction. The lowest Address bit (A0) must equal 0 and only two dummy clocks are required prior to the data output.

Continuous Read Mode

The Word Read Quad I/O instruction can further reduce instruction overhead through setting the “Continuous Read Mode” bits (M7-0) after the input Address bits (A23-0), as shown in Figure 7-50. The upper nibble of the (M7-4) controls the length of the next Word Read Quad I/O instruction through the inclusion or exclusion of the first byte instruction code. The lower nibble bits of the (M[3:0]) are don't care (“X”). However, the IO pins should be high-impedance prior to the falling edge of the first data out clock.

If the “Continuous Read Mode” bits $M[7-4]=Ah$, then the next Fast Read Quad I/O instruction (after \overline{CS} is raised and then lowered) does not require the E7h instruction code, as shown in Figure 7-51. This reduces the instruction sequence by eight clocks and allows the Read address to be immediately entered after \overline{CS} is asserted low. If the “Continuous Read Mode” bits $M[7:4]$ do not equal to $Ah(1,0,1,0)$ the next instruction (after \overline{CS} is raised and then lowered) requires the first byte instruction code, thus returning to normal operation.

Figure 7-50. Word Read Quad I/O instruction (Initial instruction or previous set $M7-0 \neq Ah$, SPI Mode)

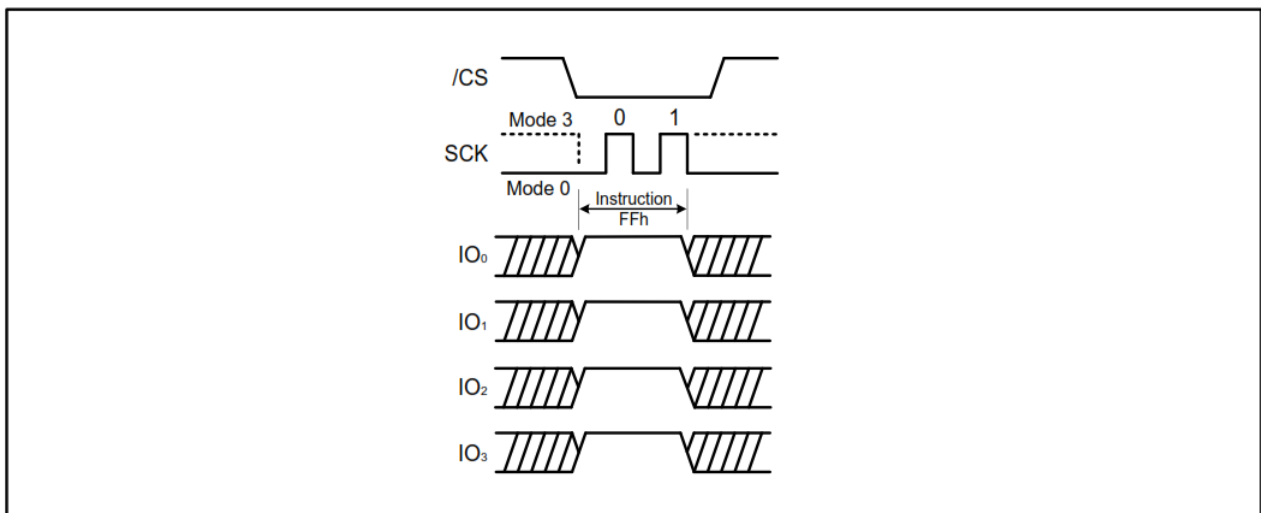
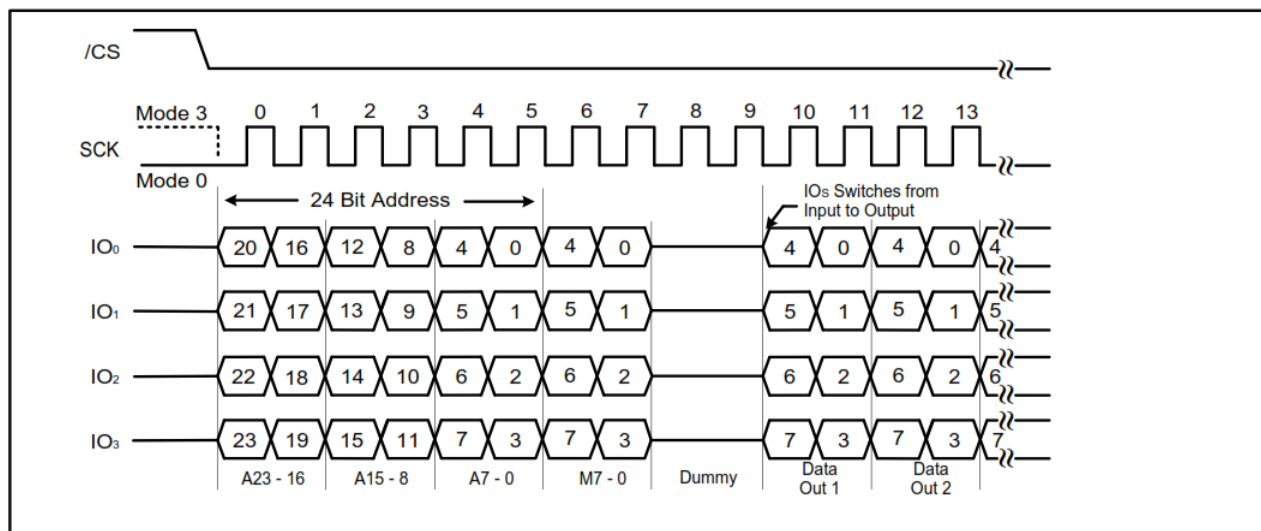

Figure 7-51. Word Read Quad I/O instruction (Previous instruction set $M7-0=Ah$, SPI Mode)



Wrap Around in SPI mode

The Word Read Quad I/O instruction can also be used to access a specific portion within a page by issuing a “Set Burst with Wrap” (77h) instruction prior to E7h. The “Set Burst with Wrap” (77h) instruction can either enable or disable the “Wrap Around” feature for the following E7h commands. When “Wrap Around” is enabled, the output data starts at the initial address specified in the instruction, once it reaches the ending boundary of the 8/16/32/64-byte section, the output will wrap around to the beginning boundary automatically until \overline{CS} is pulled high to terminate the instruction.

The Burst with Wrap feature allows applications that use cache to quickly fetch a critical address and then fill the cache afterwards within a fixed length (8/16/32/64-byte) of data without issuing read instructions.

The “Set Burst with Wrap” instruction allows three “Wrap Bits”, W6-4 to be set. The W4 bit is used to enable or disable the “Wrap Around” operation while W6-5 is used to specify the length of the wrap around section within a page. See 10.35 for detail descriptions.

7.31 Set Burst with Wrap (77h)

The Set Burst with Wrap (77h) instruction is used in conjunction with “Fast Read Quad I/O” and “Word Read Quad I/O” instructions to access a fixed length of 8/16/32/64-byte section within a 256-byte page. Certain applications can benefit from this feature and improve the overall system code execution performance. Before the device will accept the Set Burst with Wrap instruction, a Quad enable of Status Register-2 must be executed (Status Register bit QE must equal 1).

The Set Burst with Wrap instruction is initiated by driving the \overline{CS} pin low and then shifting the instruction code “77h” followed by 24 dummy bits and 8 “Wrap Bits”, W7-0. The instruction sequence is shown in Set Burst with Wrap Instruction Sequence. Wrap bit W7 and W3-0 are not used.

| W6, W5 | W4 = 0 | | W4 = 1(Default) | |
|--------|-------------|-------------|-----------------|-------------|
| | Wrap Around | Wrap Length | Wrap Around | Wrap Length |
| 00 | Yes | 8-byte | No | N/A |
| 01 | Yes | 16-byte | No | N/A |
| 10 | Yes | 32-byte | No | N/A |
| 11 | Yes | 64-byte | No | N/A |

Once W6-4 is set by a Set Burst with Wrap instruction, all the following “Fast Read Quad I/O” and Word Read Quad I/O instructions will use the W6-4 setting to access the 8/16/32/64-byte section within any page. To exit the “Wrap Around” function and return to normal read operation, another Set Burst with Wrap instruction should be issued to set W4 = 1. The default value of W4 upon power on is 1. In the case of a system Reset while W4 = 0, it is recommended that the controller issues a Set Burst with Wrap instruction or Reset (99h) instruction to reset W4 = 1 prior to any normal Read instructions since AT25SL321 does not have a hardware Reset Pin.

Figure 7-52. Set Burst with Wrap Instruction Sequence

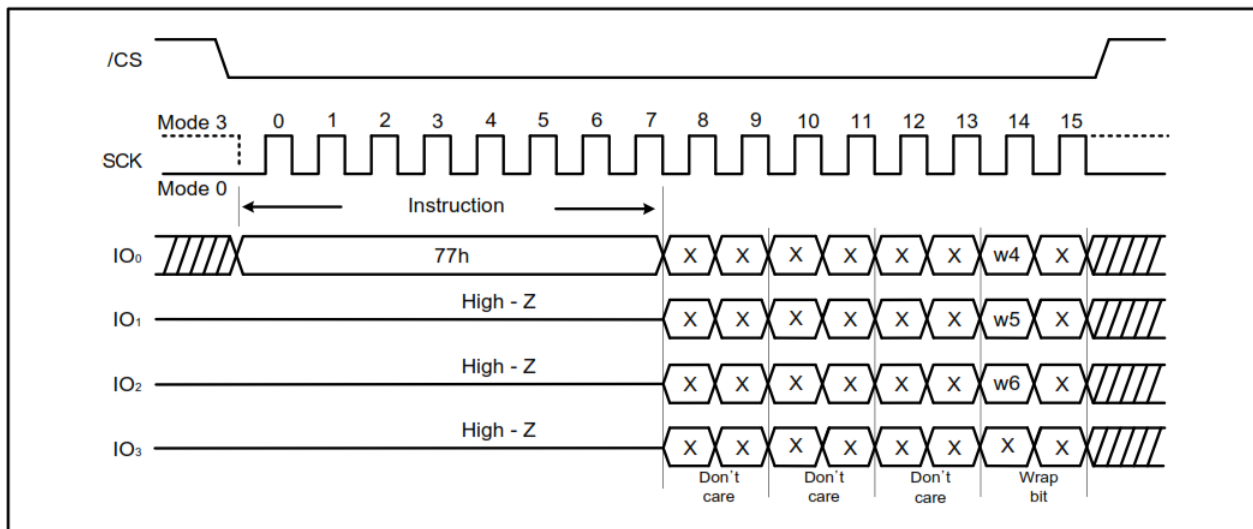

7.32 Burst Read with Wrap (0Ch)

The “Burst Read with Wrap (0Ch)” instruction provides an alternative way to perform the read operation with “Wrap Around” in QPI mode. The instruction is similar to the “Fast Read (0Bh)” instruction in QPI mode, except the addressing of the read operation will “Wrap Around” to the beginning boundary of the “Wrap Length” once the ending boundary is reached.

The “Wrap Length” and the number of dummy of clocks can be configured by the “Set Read Parameters (C0h)” instruction.

Figure 7-53. Burst Read with Wrap instruction (QPI Mode, 80MHz)

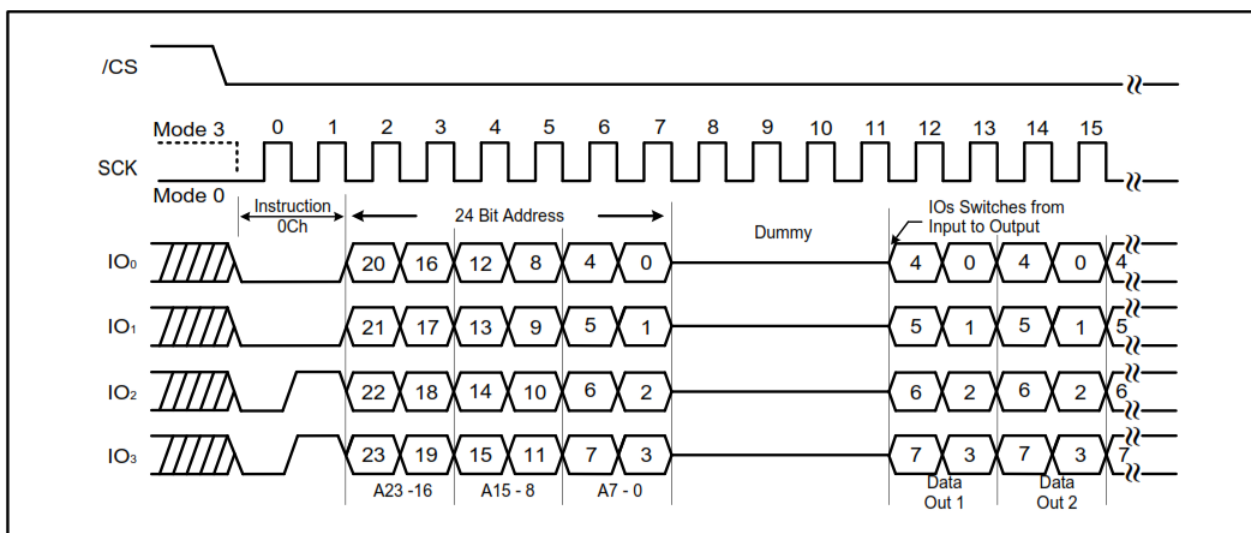
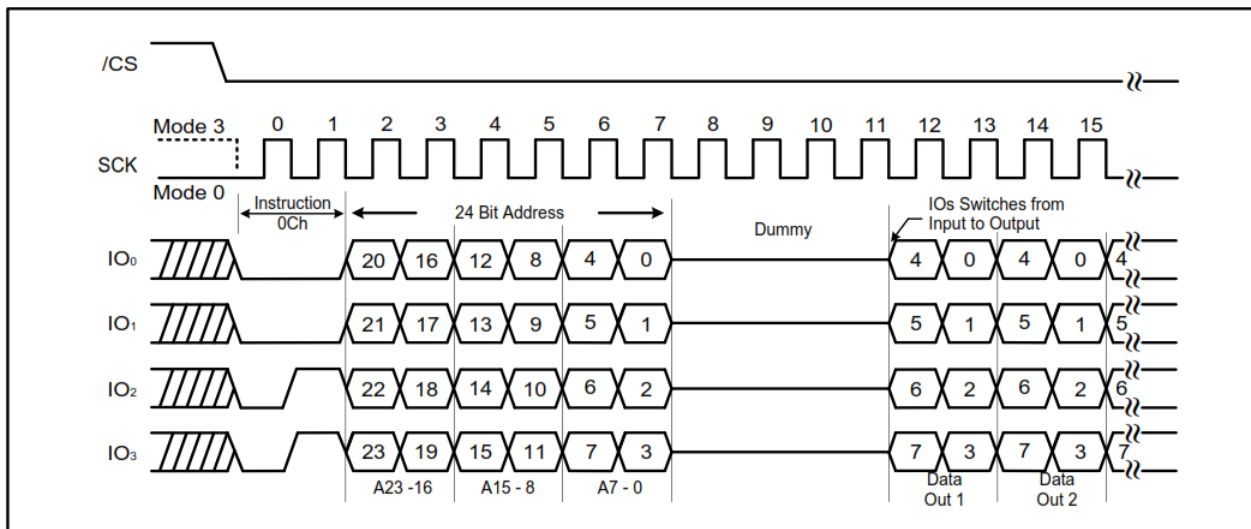

Figure 7-54. Burst Read with Wrap instruction (QPI Mode, 104MHz)



7.33 Set Read Parameters (C0h)

In QPI mode, to accommodate a wide range of applications with different needs for either maximum read frequency or minimum data access latency, “Set Read Parameters (C0h)” instruction can be used to configure the number of dummy clocks for “Fast Read (0Bh)”, “Fast Read Quad I/O (EBh)” & “Burst Read with Wrap (0Ch)” instructions, and to configure the number of bytes of “Wrap Length” for the “Burst Read with Wrap (0Ch)” instruction.

In Standard SPI mode, the “Set Read Parameters (C0h)” instruction is not accepted. The dummy clocks for various Fast Read instructions in Standard/Dual/Quad SPI mode are fixed, please refer to the instruction. and for details [Table 7.1](#), [Table 7-3](#), [Table 7-4](#), and [Table 7-5](#). The “Wrap Length” is set by W6-5 bit in the “Set Burst with Wrap (77h)” instruction. This setting will remain unchanged when the device is switched from Standard SPI mode to QPI mode.

The default “Wrap Length” after a power up or a Reset instruction is 8 bytes, the default number of dummy clocks is 4.

| P4 | Dummy Clocks | Maximum Read Freq. |
|-----|--------------|--------------------|
| 0 0 | 4 | 80MHz |
| 1 1 | 8 | 104MHz* |

| P1, P0 | Wrap Length |
|--------|-------------|
| 0 0 | 8-byte |
| 0 1 | 16-byte |
| 1 0 | 32-byte |
| 1 1 | 64-byte |

Figure 7-55. Set Read Parameters instruction (QPI Mode)

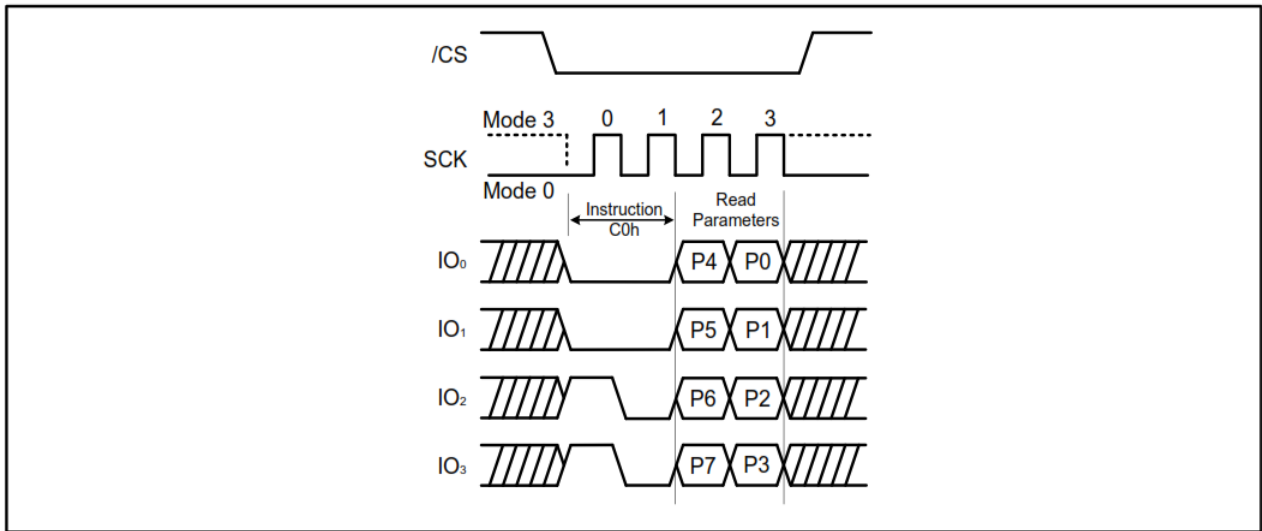

7.34 Enable Reset (66h) and Reset (99h)

Because of the small package and the limitation on the number of pins, the AT25SL321 provide a software Reset instruction instead of a dedicated RESET pin.

Once the Reset instruction is accepted, any on-going internal operations will be terminated and the device will return to its default power-on state and lose all the current volatile settings, such as Volatile Status Register bits, Write Enable Latch (WEL) status, Program/Erase Suspend status, Continuous Read Mode bit setting, Read parameter setting and Wrap bit setting.

“Enable Reset (66h)” and “Reset (99h)” instructions can be issued in either SPI mode or QPI mode. To avoid accidental reset, both instructions must be issued in sequence. Any other instructions other than “Reset (99h)” after the “Enable (66h)” instruction will disable the “Reset Enable” state. A new sequence of “Enable Reset (66h)” and “Reset (99h)” is needed to reset the device. Once the Reset instruction is accepted by the device will take approximately $t_{RST} = 30\mu s$ to reset. During this period, no instruction will be accepted.

Data corruption may happen if there is an on-going or suspended internal Erase or Program operation when Reset instruction sequence is accepted by device. It is recommended to check the BUSY bit and the SUS bit in Status Register before issuing the Reset instruction sequence.

Figure 7-56. Enable Reset and Reset Instruction (SPI Mode)

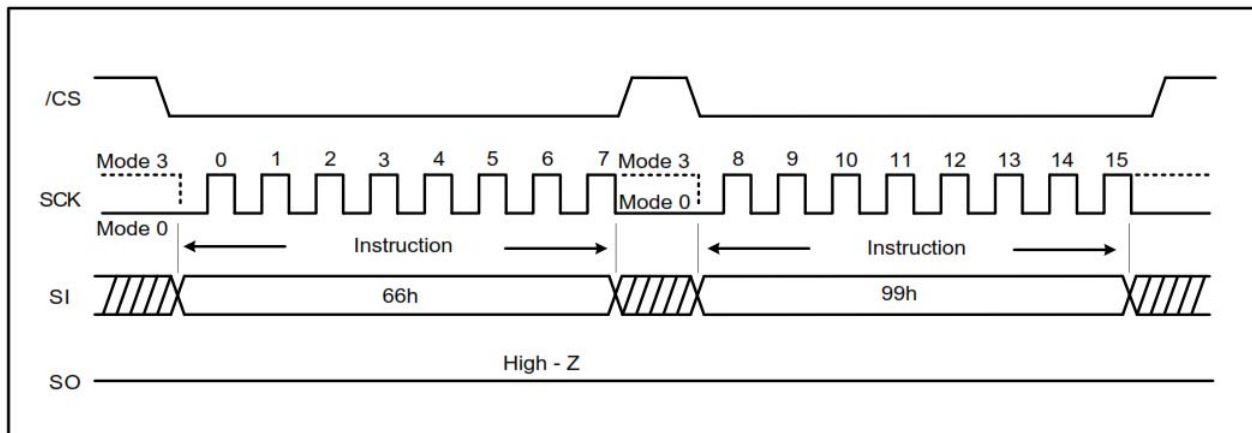
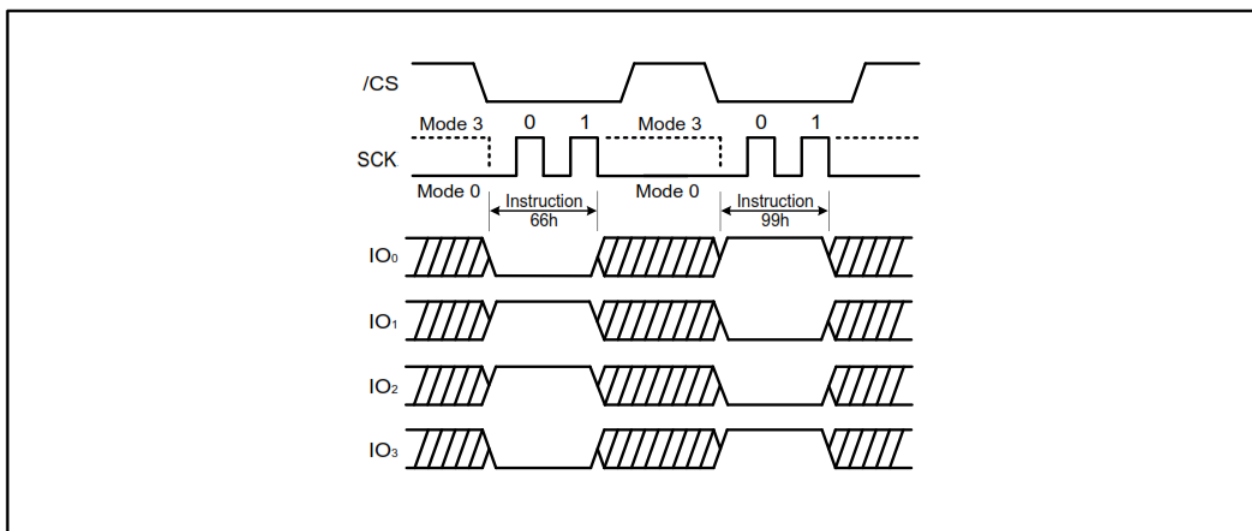

Figure 7-57. Enable Reset and Reset Instruction (QPI Mode)



7.35 Read Serial Flash Discovery Parameter (5Ah)

The Read Serial Flash Discovery Parameter (SFDP) instruction allows reading the Serial Flash Discovery Parameter area (SFDP). This SFDP area is composed of 2048 read-only bytes containing operating characteristics and vendor specific information. The SFDP area is factory programmed. If the SFDP area is blank, the device is shipped with all the SFDP bytes at FFh. If only a portion of the SFDP area is written to, the portion not used is shipped with bytes in erased state (FFh). The instruction sequence for the read SFDP has the same structure as that of a Fast Read instruction. First, the device is selected by driving Chip Select (\overline{CS}) Low. Next, the 8-bit instruction code (5Ah) and the 24-bit address are shifted in, followed by 8 dummy clock cycles. The bytes of SFDP content are shifted out on the Serial Data Output (SO) starting from the specified address. Each bit is shifted out during the falling edge of Serial Clock (SCK). The instruction sequence is shown here. The Read SFDP instruction is terminated by driving Chip Select (\overline{CS}) High at any time during data output.

Figure 7-58. Read SFDP Register Instruction

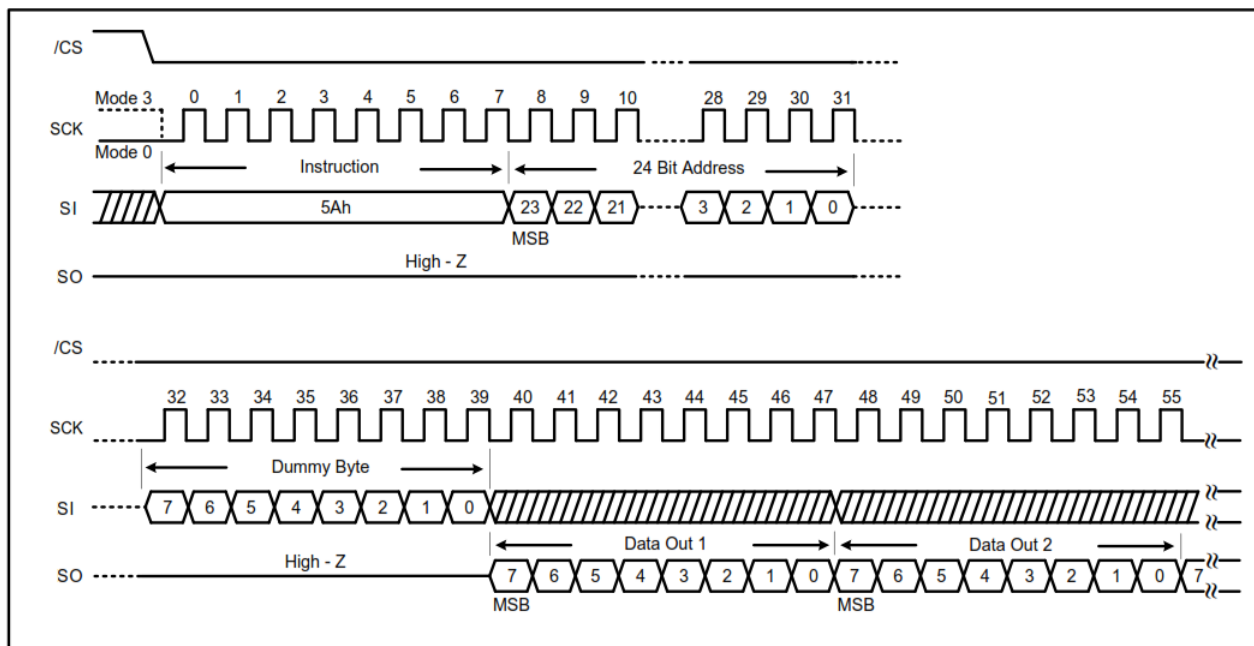

Table 7-6. SFDP Signature and Headers

| Description | Comment | Address (h) Byte | Address (Bit) | Data (b) (Bit) | Data (h) (Byte) |
|---------------------------------------|--|------------------|---------------|----------------|-----------------|
| SFDP Signature | | 00h | 07:00 | 0101 0011 | 53h |
| | | 01h | 15:08 | 0100 0110 | 46h |
| | | 02h | 23:16 | 0100 0100 | 44h |
| | | 03h | 31:24 | 0101 0110 | 50h |
| SFDP Minor Revision | Start from 00h | 04h | 07:00 | 0000 0110 | 06h |
| SFDP Major Revision | Start from 01h | 05h | 15:08 | 0000 0001 | 01h |
| Number of Parameters Headers | Start from 00h | 06h | 23:16 | 0000 0001 | 01h |
| Reserved | FFh | 07h | 31:24 | 1111 1111 | FFh |
| JEDEC Parameter ID (LSB) | JEDEC Parameter ID (LSB) = 00H | 08h | 07:00 | 0000 0000 | 00h |
| Parameter Table Minor Revision | Start from 00H | 09h | 15:08 | 0000 0110 | 06h |
| Parameter Table Major Revision | Start from 01H | 0Ah | 23:16 | 0000 0001 | 01h |
| Parameter Table Length (double words) | How many DWORDS in the parameter table | 0Bh | 31:24 | 0001 0000 | 10h |

| Description | Comment | Address (h) Byte | Address (Bit) | Data (b) (Bit) | Data (h) (Byte) |
|---------------------------------------|--|------------------|---------------|----------------|-----------------|
| Parameter Table Pointer | Address of Adesto Parameter Table | 0Ch | 07:00 | 0011 0000 | 30h |
| | | 0Dh | 15:08 | 0000 0000 | 00h |
| | | 0Eh | 23:16 | 0000 0000 | 00h |
| JEDEC Parameter ID (MSB) | JEDEC Parameter ID (MSB):FFH | 0Fh | 31:24 | 1111 1111 | FFh |
| JEDEC Parameter ID (LSB) | Adesto Manufacturer ID | 10h | 07:00 | 0001 1111 | 1Fh |
| Parameter Table Minor Revision | Start from 00H | 11h | 15:08 | 0000 0000 | 00h |
| Parameter Table Major Revision | Start from 01H | 12h | 23:16 | 0000 0001 | 01h |
| Parameter Table Length (double words) | How many DWORDs in the parameter table | 13h | 31:24 | 0000 0010 | 02h |
| Parameter Table Pointer (PTP) | Address of Adesto Parameter Table | 14h | 07:00 | 1000 0000 | 80h |
| | | 15h | 15:08 | 0000 0000 | 00h |
| | | 16h | 23:16 | 0000 0000 | 00h |
| Reserved | FFh | 17h | 31:24 | 0000 0001 | 01h |

Table 7-7. SFDP Parameters Table 1

| Description | Comment | Address (h) Byte | Address (Bit) | Data (b) (Bit) | Data (h) (Byte) |
|--|---|------------------|---------------|----------------|-----------------|
| Erase Granularity | 01:4KB available 11:4KB not available | 30h | 01:00 | 01 | E5h |
| Write Granularity | 0:1Byte, 1:64 bytes or larger | | 02 | 1 | |
| Volatile Status Register Block Protect Bits | 0: Nonvolatile status bit 1: Volatile status bit | | 03 | 0 | |
| Volatile Status Register Write Enable Opcode | 0:50H Opcode to enable, if bit-3 = 1 | | 04 | 0 | |
| Reserved | | | 07:05 | 111 | |
| 4KB Erase Opccode | Opcode or FFh | 31h | 15:08 | 0010 0000 | 20h |

| Description | Comment | Address (h) Byte | Address (Bit) | Data (b) (Bit) | Data (h) (Byte) |
|---|---|------------------|---------------|----------------|-----------------|
| Fast Dual Read Output (1 -1 -2) | 0=Not supported, 1=Supported | 32h | 16 | 1 | F1h |
| Number of Address Bytes | 00:3 Byte only 01:3 or 4 Byte 10:4 Byte only 11:Reserved | | 18:17 | 00 | |
| Double Transfer Rate (DTR) Clocking | 0=Not supported, 1=Supported | | 19 | 0 | |
| Fast Dual I/O Read (1-2- 2) | 0=Not supported, 1=Supported | | 20 | 1 | |
| Fast Quad I/O Read (1-4-4) | 0=Not supported, 1=Supported | | 21 | 1 | |
| Fast Quad Output Read (1-1-4) | 0=Not supported, 1=Supported | | 22 | 1 | |
| Reserved | FFh | | 23 | 1 | |
| Reserved | FFh | 33h | 31:24 | 1111 1111 | FFh |
| Flash Memory Density | | 34h | 07:00 | 1111 1111 | FFh |
| | | 35h | 15:08 | 1111 1111 | FFh |
| | | 36h | 23:16 | 1111 1111 | FFh |
| | | 37h | 31:24 | 0000 0001 | 01h |
| Fast Quad I/O (1-4-4) Number of dummy clocks | number of dummy clocks | 38h | 04:00 | 00100 | 44h |
| Fast Quad I/O (1-4-4) Number of mode bits | number of mode bits | | 07:05 | 010 | |
| Fast Quad I/O (1-4-4) Read Opcode | Opcode or FFh | 39h | 15:08 | 1110 1011 | EBh |
| Fast Quad Output (1-1-4) Number of dummy clocks | number of dummy clocks | 3Ah | 20:16 | 01000 | 08h |
| Fast Quad Output (1-1-4) Number of mode bits | number of mode bits | | 23:21 | 000 | |
| Fast Quad Output (1-1-4) Read Opcode | Opcode or FFh | 3Bh | 31:24 | 0110 1011 | 6Bh |
| Fast Dual Output (1-1-2) Number of dummy clocks | number of dummy clocks | 3Ch | 04:00 | 01000 | 08h |
| Fast Dual Output (1-1-2) Number of mode bits | number of mode bits | | 07:05 | 000 | |
| Fast Dual Output (1-1-2) Read Opcode | Opcode or FFh | 3Dh | 15:08 | 0011 1011 | 3Bh |

| Description | Comment | Address (h) Byte | Address (Bit) | Data (b) (Bit) | Data (h) (Byte) |
|---|--|------------------|---------------|----------------|-----------------|
| Fast Dual I/O (1-2-2) Number of dummy clocks | number of dummy clocks | 3Eh | 20:16 | 00000 | 80h |
| Fast Dual I/O (1-2-2) Number of mode bits | number of mode bits | | 23:21 | 100 | |
| Fast Dual I/O (1-2-2) Read Opcode | Opcode or FFh | 3Fh | 31:24 | 1011 1011 | BBh |
| Fast Dual DPI (2-2-2) | 0=Not supported, 1=Supported | 40h | 0 | 0 | FEh |
| Reserved | FFh | | 03:01 | 111 | |
| Fast Quad QPI (4-4-4) | 0=Not supported, 1=Supported | | 04 | 1 | |
| Reserved | FFh | | 07:05 | 111 | |
| Reserved | FFh | 41h | 15:08 | 1111 1111 | FFh |
| Reserved | FFh | 42h | 23:16 | 1111 1111 | FFh |
| Reserved | FFh | 43h | 31:24 | 1111 1111 | FFh |
| Reserved | FFh | 44h | 07:00 | 1111 1111 | FFh |
| Reserved | FFh | 45h | 15:08 | 1111 1111 | FFh |
| Fast Dual DPI (2-2-2) Number of dummy clocks | number of dummy clocks | 46h | 20:16 | 0 0000 | 00h |
| Fast Dual DPI (2-2-2) Number of mode bits | number of mode bits | | 23:21 | 000 | |
| Fast Dual DPI(2-2-2) Read Opcode | Opcode or FFh | 47h | 31:24 | 1111 1111 | FFh |
| Reserved | FFh | 48h | 07:00 | 1111 1111 | FFh |
| Reserved | FFh | 49h | 15:08 | 1111 1111 | FFh |
| Fast Quad QPI (4-4-4) Number of dummy clocks | number of dummy clocks | 4Ah | 20:16 | 00010 | 42h |
| Fast Quadl QPI (4-4-4) Number of mode bits | number of mode bits | | 23:21 | 010 | |
| Fast Quad QPI(4-4-4) Read Opcode | Opcode or FFh | 4Bh | 31:24 | 1110 1011 | EBh |
| Erase type-1 Size | 4KB=2 ⁰ Ch, 32KB=2 ⁰ Fh,64KB=2 ¹ 0h; (2 ^N Nbyte) | 4Ch | 07:00 | 0000 1100 | 0Ch |
| Erase type-1 Opcode | Opcode or FFh | 4Dh | 15:08 | 0010 0000 | 20h |
| Erase type-2 Size | 4KB=2 ⁰ Ch, 32KB=2 ⁰ Fh,64KB=2 ¹ 0h; (2 ^N Nbyte) | 4Eh | 23:16 | 0000 1111 | 0Fh |
| Erase type-2 Opcode | Opcode or FFh | 4Fh | 31:24 | 0101 0010 | 52h |

| Description | Comment | Address (h) Byte | Address (Bit) | Data (b) (Bit) | Data (h) (Byte) |
|-------------------------------|--|--------------------------|---------------|----------------|--------------------------|
| Erase Type-3 Size | 4KB=2 ⁰ Ch, 32KB=2 ⁰ Fh,64KB=2 ¹ 0h; (2 ^N Nbyte) | 50h | 07:00 | 0001 0000 | 10h |
| Erase Type-3 Opcode | Opcode or FFh | 51h | 15:08 | 1101 1000 | D8h |
| Erase Type-4 Size | 4KB=2 ⁰ Ch, 32KB=2 ⁰ Fh,64KB=2 ¹ 0h; (2 ^N Nbyte) | 52h | 23:16 | 0000 0000 | 00h |
| Erase Type-4 Opcode | Opcode or FFh | 53h | 31:24 | 1111 1111 | FFh |
| Erase Maximum/Typical Ratio | Maximum = 2 * (COUNT + 1) * Typical | 54h 55h 56h 57h | 03:00 | 0011 | 33h 62h D5h 00h |
| Erase type-1 Typical time | Count or 00h | | 08:04 | 0 0011 | |
| Erase type-1 Typical units | 00b: 1ms 01b: 16ms 10b: 128ms 11b: 1s | | 10:09 | 01 | |
| Erase type-2 Typical time | Count or 00h | | 15:11 | 0110 0 | |
| Erase type-2 Typical units | 00b: 1ms 01b: 16ms 10b: 128ms 11b: 1s | | 17:16 | 01 | |
| Erase type-3 Typical time | Count or 00h | | 22:18 | 101 01 | |
| Erase type-3 Typical units | 00b: 1ms 01b: 16ms 10b: 128ms 11b: 1s | | 24:23 | 01 | |
| Erase type-4 Typical time | Count or 00h | | 29:25 | 00 000 | |
| Erase type-4 Typical units | 00b: 1ms 01b: 16ms 10b: 128ms 11b: 1s | | 31:30 | 00 | |
| Program Maximum/Typical Ratio | Maximum = 2 * (COUNT + 1) * Typical | | 58h | 03:00 | |
| Page Size | 2 ^N bytes | | 07:04 | 1000 | |

| Description | Comment | Address (h) Byte | Address (Bit) | Data (b) (Bit) | Data (h) (Byte) |
|---------------------------------------|--|-------------------|---------------|----------------|-------------------|
| Program Page Typical time | Count or 00h | 59h 5Ah 5Bh | 12:08 | 0 1001 | 29h 01h C4h |
| Program Page Typical units | 0: 8us, 1: 64us | | 13 | 1 | |
| Program Byte Typical time, 1st byte | Count or 00h | | 17:14 | 01 00 | |
| Program Byte Typical units, 1st byte | 0: 1us, 1: 8us | | 18 | 0 | |
| Program Additional Byte Typical time | Count or 00h | | 22:19 | 000 0 | |
| Program Additional Byte Typical units | 0: 1us, 1: 8us | | 23 | 0 | |
| Erase Chip Typical time | Count or 00h | | 28:24 | 0 0100 | |
| Erase Chip Typical units | 00b: 16ms 01b: 256ms 10b: 4s 11b: 64s | | 30:29 | 10 | |
| Reserved | 1h | | 31 | 1 | |
| Prohibited Op during Program Suspend | see datasheet | 5Ch | 03:00 | 11010 | ECh |
| Prohibited Op during Erase Suspend | see datasheet | | 07:04 | 1110 | |

| Description | Comment | Address (h) Byte | Address (Bit) | Data (b) (Bit) | Data (h) (Byte) |
|--------------------------------|---|-------------------|---------------|----------------|-------------------|
| Reserved | 1h | 5Dh 5Eh 5Fh | 08 | 1 | A1h 07h 3Dh |
| Program Resume to Suspend time | Count of 64us | | 12:09 | 0 000 | |
| Program Suspend Maximum time | Count or 00h | | 17:13 | 11 101 | |
| Program Suspend Maximum units | 00b: 128ns, 01b: 1us, 10b: 8us, 11b: 64us | | 19:18 | 01 | |
| Erase Resume to Suspend time | Count of 64us | | 23:20 | 0000 | |
| Erase Suspend Maximum time | Count or 00h | | 28:24 | 1 1101 | |
| Erase Suspend Maximum units | 00b: 128ns, 01b: 1us, 10b: 8us, 11b: 64us | | 30:29 | 01 | |
| Suspend / Resume supported | 0: Program and Erase suspend supported 1: not supported | | 31 | 0 | |
| Program Resume Opcode | Opcode or FFh | 60h | 7:0 | 0111 1010 | 7Ah |
| Program Suspend Opcode | Opcode or FFh | 61h | 15:8 | 0111 0101 | 75h |
| Resume Opcode | Opcode or FFh | 62h | 23:16 | 0111 1010 | 7Ah |
| Suspend Opcode | Opcode or FFh | 63h | 31:24 | 0111 0101 | 75h |
| Reserved | 11b | 64h | 01:00 | 11 | F7h |
| Status Register Busy Polling | xxxx1b: Opcode = 05h, bit-0 = 1 Busy, xxxx1xb: Opcode = 70h, bit-7 = 0 Busy, others: reserved | | 07:02 | 1111 01 | |

| Description | Comment | Address (h) Byte | Address (Bit) | Data (b) (Bit) | Data (h) (Byte) |
|--|--|-------------------|---------------|----------------|-------------------|
| Exit Deep Powerdown time | Count or 00h | 65h 66h 67h | 12:08 | 0 0010 | A2h D5h 5Ch |
| Exit Deep Powerdown units | 00b: 128ns, 01b: 1us, 10b: 8us, 11b: 64us | | 14:13 | 01 | |
| Exit Deep Powerdown Opcode | Opcode or FFh | | 22:15 | 101 0101 1 | |
| Enter Deep Powerdown Opcode | Opcode or FFh | | 30:23 | 101 1100 1 | |
| Deep Powerdown Supported | 0: Deep Powerdown supported, 1: not supported | | 31 | 0 | |
| Disable 4-4-4 Read Mode | | 68h 69h 6Ah | 03:00 | 1001 | 19h F6h 1Ch |
| Enable 4-4-4 Read Mode | | | 08:04 | 0 0001 | |
| Fast Quad I/O Continuous (0-4-4) supported | 0: not supported, 1: Quad I/O 0-4-4 supported | | 09 | 1 | |
| Fast Quad I/O Continuous (0-4-4) Exit | | | 15:10 | 1111 01 | |
| Fast Quad I/O Continuous (0-4-4) Enter | | | 19:16 | 1100 | |
| Quad Enable Requirements (QER) | | | 22:20 | 001 | |
| HOLD or RESET Disable | 0: not supported, 1: use Configuration Register bit-4 | | 23 | 0 | |
| Reserved | FFh | 6Bh | 31:24 | 1111 1111 | FFh |
| Status Register Opcode | | 6Ch | 06:00 | 110 1000 | E8h |
| Reserved | 1h | | 07 | 1 | |
| Soft Reset Opcodes | | 6Dh | 13:08 | 01 0000 | 10h C0h |
| 4-Byte Address Exit | | 6Eh | 23:14 | 1100 0000 00 | |
| 4-Byte Address Enter | | 6Fh | 31:24 | 1000 0000 | 80h |

Table 7-8. SFDP Parameters Table 2

| Description | Comment | Address (h) Byte | Address (Bit) | Data (b) (Bit) | Data (h) (Byte) |
|------------------------------------|--|------------------|---------------|------------------------|-----------------|
| VCC Minimum Voltage | 1650h: 1.65V, 1700h: 1.70V, 2300h: 2.30V, 2500h: 2.50V, 2700h: 2.70V | 80h 81h | 15:0 | 0000 0000 0001 0111 | 00h 17h |
| VCC Maximum Voltage | 1950h: 1.95V, 3600h: 3.60V, 4000h: 4.00V, 4400h: 4.40V | 82h 83h | 31:16 | 0000 0000 0010 0000 | 00h 20h |
| Array Protection Method | 10b: use non-volatile status register | 84h 85h | 01:00 | 00 | 00h 00h |
| Power up Protection default | 0: power up unprotected, 1: power up protected | | 02 | 0 | |
| Protection Disable Opcodes | 011b: use status register | | 05:03 | 00 0 | |
| Protection Enable Opcodes | 011b: use status register | | 08:06 | 0 00 | |
| Protection Read Opcodes | 011b: use status register | | 11:09 | 000 | |
| Protection Register Erase Opcode | 00b: not supported, 01b: Opcodes 3Dh,2Ah,7Fh,CFh, | | 13:12 | 00 | |
| Protection Register Program Opcode | 00b: not supported, 01b: Opcodes 3Dh,2Ah,7Fh,FCh | | 15:14 | 00 | |
| Reserved | FFh | 86h | 23:16 | 1111 1111 | FFh |
| Reserved | FFh | 87h | 31:24 | 1111 1111 | FFh |
| Reserved | FFh | 88h-FFh | | | Reserved |

7.36 Enter Secured OTP (B1h)

The Enter Secured OTP instruction is for entering the additional 4K-bit secured OTP mode. The additional 4K-bit secured OTP is independent from main array, which may be used to store unique serial number for system identifier. After entering the Secured OTP mode, and then follow standard read or program, procedure to read out the data or update data. The Secured OTP data cannot be updated again once it is lock-down

Please note that Write Status Register-1, Write Status Register-2 and Write Security Register instructions are not acceptable during the access of secure OTP region. Once security OTP is lock down, only commands related with read are valid. The Enter Secured OTP instruction sequence is shown in [Figure 7-59](#).

Figure 7-59. Enter Secured OTP instruction for SPI Mode (left) and QPI Mode (right)

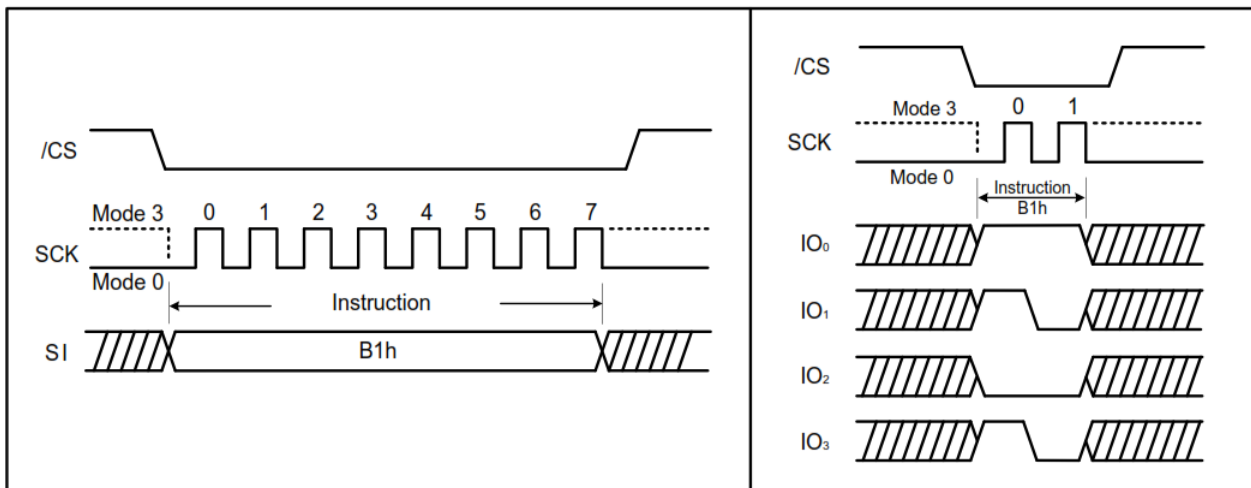

7.37 Exit Secured OTP (C1h)

The Exit Secured OTP instruction is for exiting the additional 4K-bit secured OTP mode. (Please refer to Figure 7-60).

Figure 7-60. Exit Secured OTP instruction for SPI Mode (left) and QPI Mode (right)

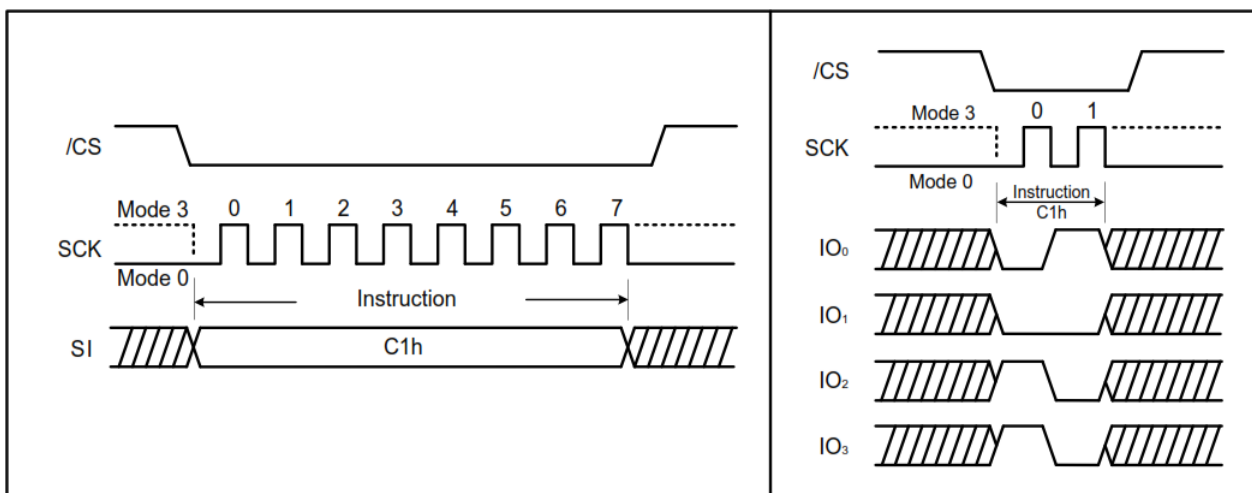

7.38 Read Security Register (2Bh)

The Read Security Register can be read the value of Security Register bits at any time (even in program/erase/write status register-1 and write status register-2 condition) and continuously.

Secured OTP Indicator bit. The Secured OTP indicator bit shows the chip is locked by factory before ex-factory or not. When it is “0”, it indicates non-factory lock, “1” indicates factory-lock.

Lock-down Secured OTP (LDSO) bit. By writing Write Security Register instruction, the LDSO bit may be set to “1” for customer lock-down purpose. However, once the bit it set to “1” (Lock-down), the LDSO bit and the 4K-bit Secured OTP area cannot be updated any more. While it is in 4K-bit Secured OTP mode, array access is not allowed to write.

Table 7-9. Security Register Definition

| Bit7 | Bit6 | Bit5 | Bit4 | Bit3 | Bit2 | Bit1 | Bit0 |
|-----------------|-----------------|-----------------|-----------------|-----------------|-----------------|--|---|
| x | x | x | x | x | x | LDSO (indicate if lock-down) | Secured OTP indicator bit |
| Reserved | Reserved | Reserved | Reserved | Reserved | Reserved | 0 = not lock-down 1 = lock- down (cannot program/ erase OTP) | 0 = non factory lock 1 = factory lock |
| Volatile bit | Volatile bit | Volatile bit | Volatile bit | Volatile bit | Volatile bit | Non- Volatile bit | Non- Volatile bit |

Figure 7-61. Read Security Register instruction (SPI Mode)

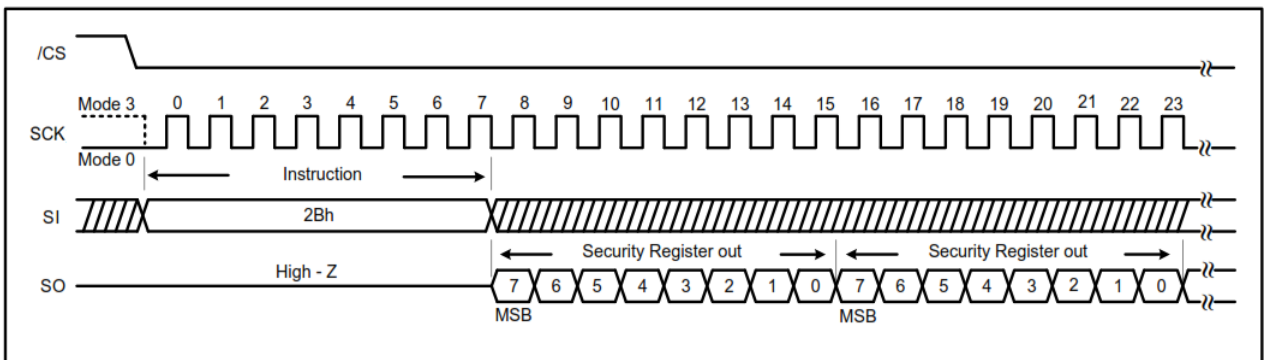
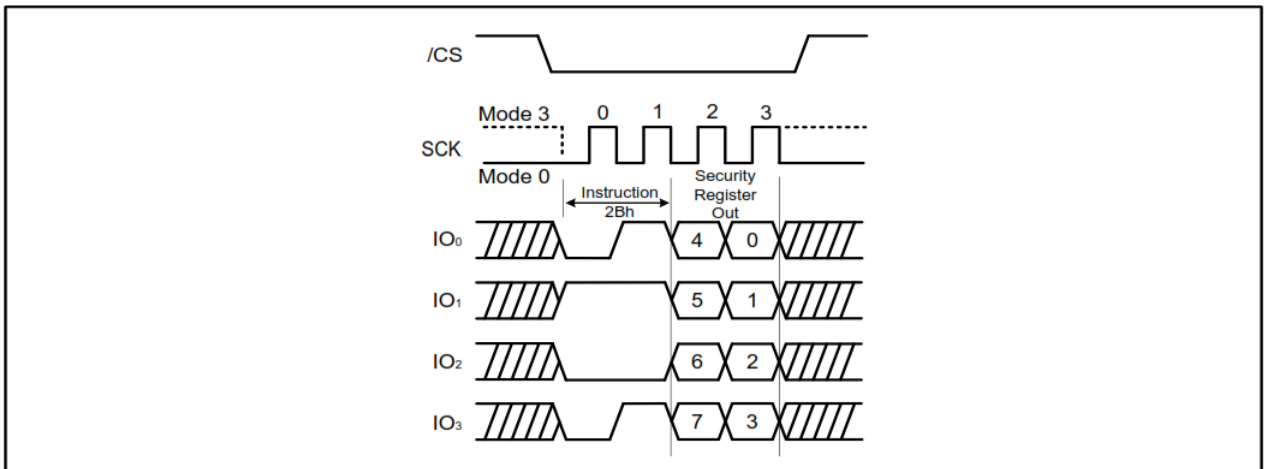

Figure 7-62. Read Security Register instruction (QPI Mode)



7.39 Write Security Register (2Fh)

The Write Security Register instruction is for changing the values of Security Register bits. Unlike Write Status Register, the Write Enable instruction is not required before writing Write Security Register instruction. The Write Security Register instruction may change the value of bit1 (LDSO bit) for customer to lock-down the 4K-bit Secured OTP area. Once the LDSO bit is set to “1”, the Secured OTP area cannot be updated any more.

The \overline{CS} must go high exactly at the boundary; otherwise, the instruction will be rejected and not executed.

Figure 7-63. Write Security Register instruction for SPI Mode (left) and QPI Mode (right)

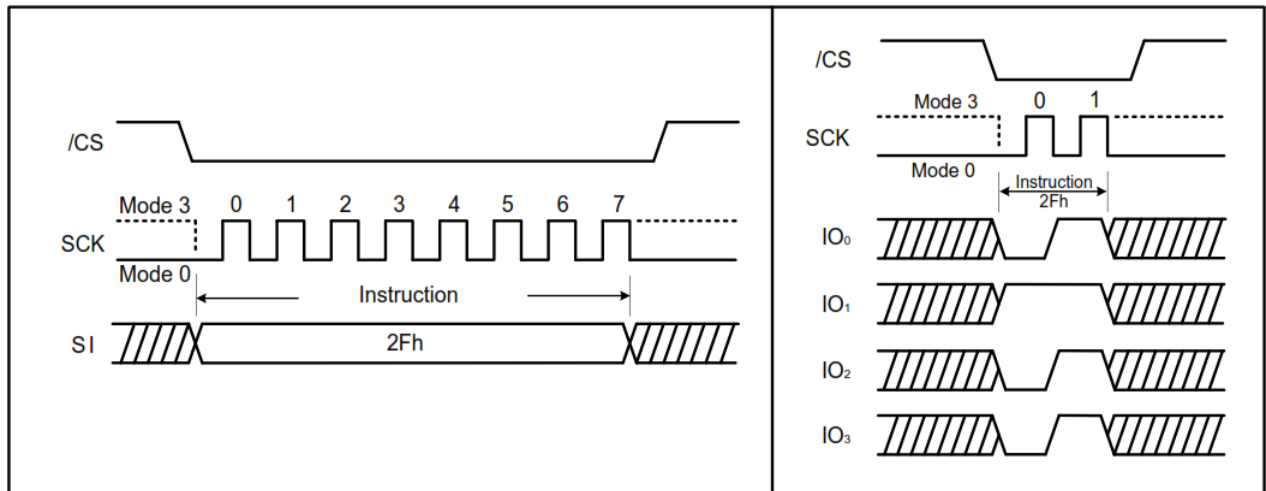

7.40 4K-bit Secured OTP

It's for unique identifier to provide 4K-bit one-time-program area for setting device unique serial number which may be set by factory or system customer. Please refer to table of “4K-bit secured OTP definition”.

- Security register bit 0 indicates whether the chip is locked by factory or not.
- To program the 4K-bit secured OTP by entering 4K-bit secured OTP mode (with ENSO command) and going through normal program procedure, and then exiting 4K-bit secured OTP mode by writing EXSO command
- Customer may lock-down bit1 as “1”. Please refer to “table of security register definition” for security register bit definition and table of “4K-bit secured OTP definition” for address range definition.

Note. Once lock-down whatever by factory or customer, it cannot be changed any more. While in 4K-bit secured OTP mode, array access is not allowed to write.

| Address Range | Size | Standard Factory Lock | Customer Lock |
|-----------------|----------|-----------------------------------|------------------------|
| 000000 ~ 00000F | 128-bit | ESN (Electrical Serial Number) | Determined by customer |
| 000010 ~ 0001FF | 3968-bit | N/A | |

8. Electrical Characteristics

8.1 Absolute Maximum Ratings⁽¹⁾

| PARAMETERS | SYMBOL | CONDITIONS | RANGE | UNIT |
|---------------------------------|--------|---------------------------------------|-------------------------|------|
| Supply Voltage | VCC | | -0.6 to VCC+0.4 | V |
| Voltage Applied to Any Pin | VIO | Relative to Ground | -0.6 to VCC +0.4 | V |
| Transient Voltage on any Pin | VIOT | <20nS Transient Relative to Ground | -1.0V to VCC +1.0V | V |
| Storage Temperature | TSTG | | -65 to +150 | °C |
| Lead Temperature | TLEAD | | See Note ⁽²⁾ | °C |
| Electrostatic Discharge Voltage | VESD | Human Body Model ⁽³⁾ | -2000 to +2000 | V |

Notes:

- Stresses beyond those listed under "Absolute Maximum Ratings" may cause permanent damage to the device. The "Absolute Maximum Ratings" are stress ratings only and functional operation of the device at these or any other conditions beyond those indicated in the operational sections of this specification is not implied. Exposure to absolute maximum rating conditions for extended periods may affect device reliability. Voltage extremes referenced in the "Absolute Maximum Ratings" are intended to accommodate short duration undershoot/overshoot conditions and does not imply or guarantee functional device operation at these levels for any extended period of time.
- Compliant with JEDEC Standard J-STD-20C for small body Sn-Pb or Pb-free (Green) assembly and the European directive on restrictions on hazardous substances (RoHS) 2002/95/EU.
- JEDEC Std JESD22-A114A (C1=100pF, R1=1500 ohms, R2=500 ohms).

8.2 Operating Ranges

| PARAMETER | SYMBOL | CONDITIONS | MIN | MAX | UNIT |
|-------------------------------|----------------|--|-----|-----|------|
| Erase/Program Cycles | VCC | FR = 104MHz (Single/Dual/Quad SPI) fR = 50MHz (Read Data 03h) | 1.7 | 2.0 | V |
| Ambient Operating Temperature | T _A | Industrial | -40 | +85 | °C |

8.3 Endurance and Data Retention

| PARAMETER | CONDITIONS | MIN | MAX | UNIT |
|----------------------|--|---------|-----|--------|
| Erase/Program Cycles | 4KB Block, 32/64KB block or full chip. | 100,000 | | Cycles |
| Data Retention | Full Temperature Range | | 20 | years |

8.4 Power-up Timing and Write Inhibit Threshold

| PARAMETER | SYMBOL | SPEC | | UNIT |
|--|---------------------|------|-----|---------------|
| | | MIN | MAX | |
| VCC(min) to $\overline{\text{CS}}$ Low | tVSL ⁽¹⁾ | 10 | | μs |
| Time Delay Before Write Instruction | tPUW ⁽¹⁾ | 1 | 10 | ms |
| Write Inhibit Threshold Voltage | VWI ⁽¹⁾ | 1.0 | 1.4 | V |

Note:

1. These parameters are characterized at -10C & +85C only

Figure 8-1. Power-up Timing and Voltage Levels

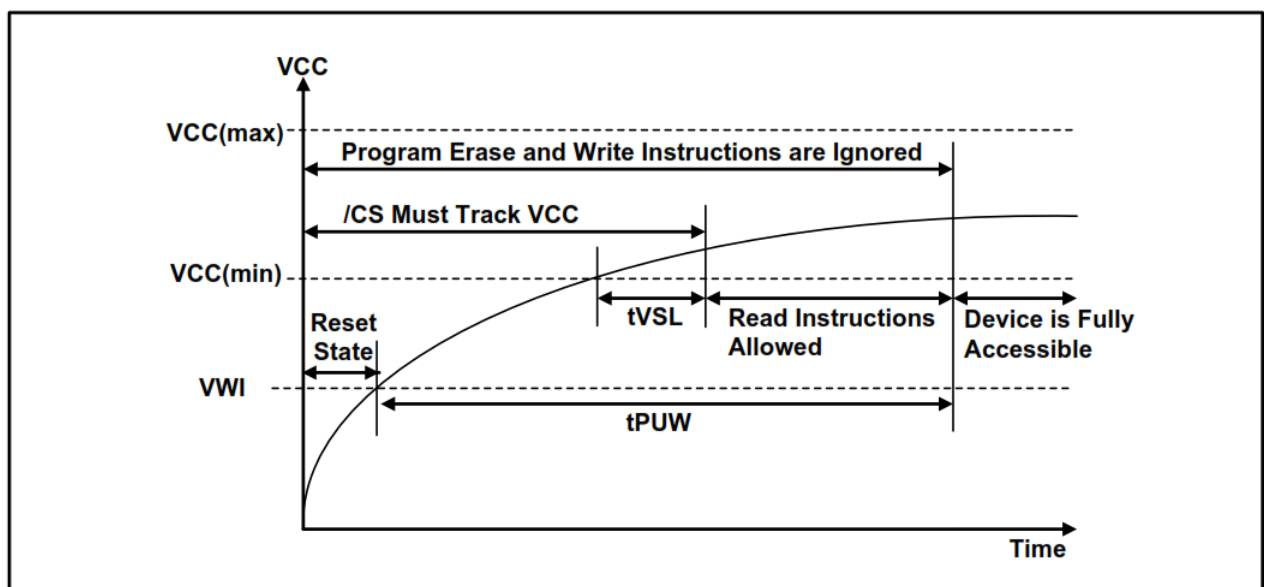

8.5 Program Acceleration via ACC Pin

The program acceleration function requires applying VHH to the ACC input, and then waiting a period of tWC. Minimum tVHH (rise & fall times) is required for ACC to change to VHH from VIL or VIH. Removing VHH from the ACC pin returns the device to normal operation after a period of tWC.

Only Read Status Register and Page Program operation are allowed when ACC is at (VHH).

The start address must be entered by the multiples of 4-byte (for example xxxxx0, xxxxx4, xxxxx8, xxxxxC). Also the data must be entered with a minimum of 4-byte and multiples of 4-byte unit when Program Acceleration via ACC Pin.

| PARAMETER | SYMBOL | SPEC | | UNIT |
|---|-----------------|------|-----|---------|
| | | MIN | MAX | |
| \overline{WP} pin High Voltage | $V_{HH}^{(1)}$ | 8.5 | 9.5 | V |
| \overline{WP} pin Voltage rise and fall time | $t_{VHH}^{(1)}$ | 2.2 | | μs |
| \overline{WP} at V_{HH} and V_{IL} or V_{IH} to first instruction | $t_{WC}^{(1)}$ | 5 | | μs |

Note:

1. These parameters are characterized only.

Figure 8-2. ACC Program acceleration Timing and Voltage Levels

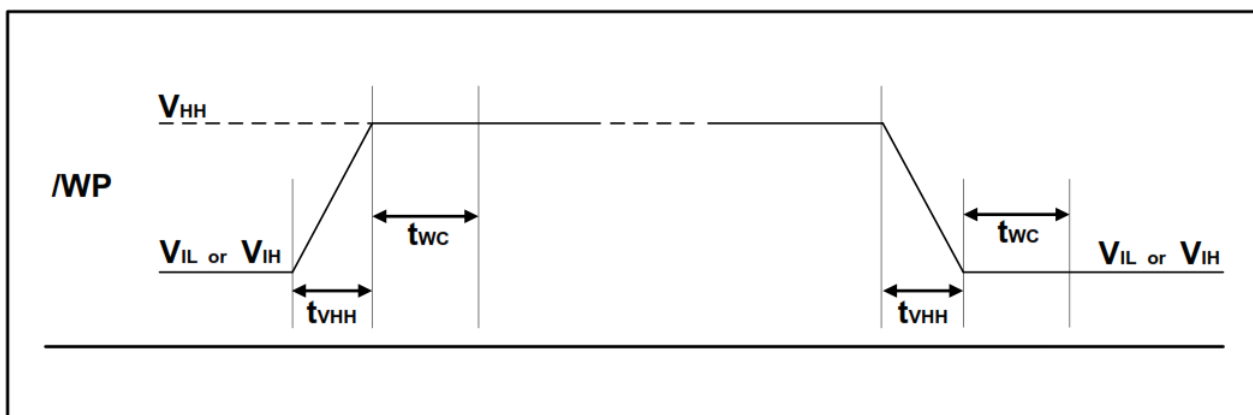

8.6 DC Electrical Characteristics

| PARAMETER | SYMBOL | CONDITION | SPEC | | | UNIT |
|---|-----------------|--|------|-----|---------|---------|
| | | | MIN | TYP | MAX | |
| Input Capacitance | $C_{IN}^{(1)}$ | $V_{IN}=0V^{(2)}$ | | | 6 | pF |
| Output Capacitance | $C_{OUT}^{(1)}$ | $V_{OUT}=0V^{(2)}$ | | | 8 | pF |
| Input Leakage | ILI | | | | ± 2 | μA |
| I/O Leakage | ILO | | | | ± 2 | μA |
| Standby Current | ICC1 | $\overline{CS}=V_{CC}$ $V_{IN}=GND$ or V_{CC} | | 10 | 50 | μA |
| Power Down Current | ICC2 | $\overline{CS}=V_{CC}$ $V_{IN}=GND$ or V_{CC} | | 2 | 20 | μA |
| Current Read Data/ Dual/Quad 1MHz ⁽²⁾ | ICC3 | $C=0.1 V_{CC} / 0.9V_{CC}$ | | | 7 | mA |

| | | | | | | |
|---|------|---------------------|----------|----|----------|----|
| Current Read Data/ Dual/Quad 50MHz ⁽²⁾ | ICC3 | C=0.1 VCC / 0.9VCC | | | 15 | mA |
| Current Read Data/ Dual/Quad 80MHz ⁽²⁾ | ICC3 | C=0.1 VCC / 0.9VCC | | | 18 | mA |
| Current Read Data/ Dual/Quad 104MHz ⁽²⁾ | ICC3 | C=0.1 VCC / 0.9VCC | | | 20 | mA |
| Current Write Status Register | ICC4 | $\overline{CS}=VCC$ | | 10 | 20 | mA |
| Current page Program | ICC5 | $\overline{CS}=VCC$ | | 15 | 25 | mA |
| Current Block Erase | ICC6 | $\overline{CS}=VCC$ | | 15 | 25 | mA |
| Current Chip Erase | ICC7 | $\overline{CS}=VCC$ | | 15 | 25 | mA |
| Input Low Voltages | VIL | | -0.5 | | VCC x0.2 | V |
| Input High Voltages | VIH | | VCC x0.8 | | VCC +0.4 | V |
| Output Low Voltages | VOL | IOL= 100 μ A | | | 0.2 | V |
| Output High Voltages | VOH | IOH=-100 μ A | VCC -0.2 | | | V |

Notes:

1. Tested on sample basis and specified through design and characterization data, TA = 25°C, VCC = 1.8V.
2. Checked Board Pattern.

8.7 AC Measurement Conditions

| PARAMETER | SYMBOL | SPEC | | UNIT |
|----------------------------------|---------------------------------|--------------------|-----|------|
| | | MIN | MAX | |
| Load Capacitance | C _L | | 30 | pF |
| Input Rise and Fall Times | T _R , T _F | | 5 | ns |
| Input Pulse Voltages | V _{IN} | 0.2 VCC to 0.8 VCC | | V |
| Input Timing Reference Voltages | IN | 0.3 VCC to 0.7 VCC | | V |
| Output Timing Reference Voltages | OUT | 0.5 VCC to 0.5 VCC | | V |

Note:

1. Output Hi-Z is defined as the point where data out is no longer driven

Figure 8-3. AC Measurement I/O Waveform

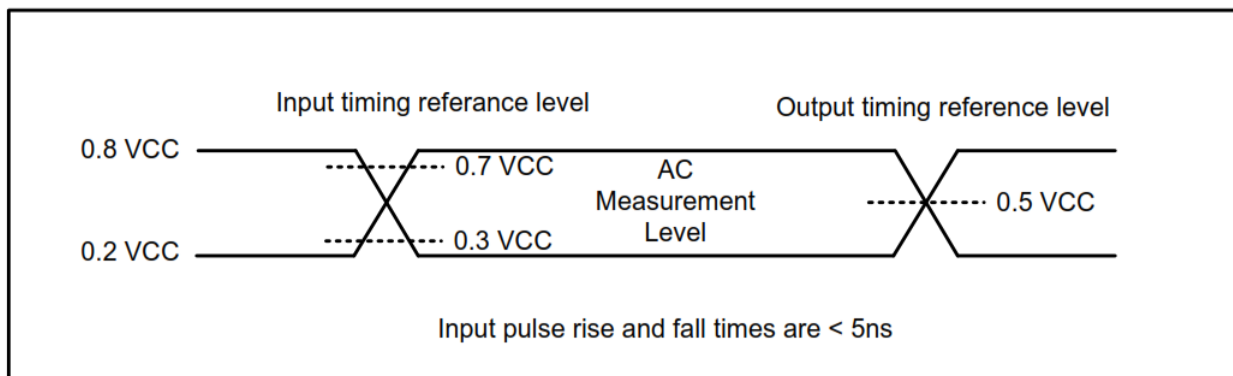

8.8 AC Electrical Characteristics

| DESCRIPTION | SYMBOL | ALT | SPEC | | | UNIT |
|--|----------------------------------|-----------|------|-----|--------------------|------|
| | | | MIN | TYP | MAX | |
| Clock frequency | | | | | | |
| For all instructions, except Read Data (03h) | f_R | f_c | D.C. | | 104 ⁽⁶⁾ | MHz |
| Clock freq. Read Data instruction (03h) | f_R | | D.C. | | 50 | MHz |
| Clock High, Low Time except Read Data (03h) | t_{CLH} , $t_{CLL}^{(1)}$ | | 4.5 | | | ns |
| Clock High, Low Time for Read Data (03h) | t_{CRLH} , $t_{CRLL}^{(1)}$ | | 8 | | | ns |
| Clock Rise Time peak to peak | $t_{CLCH}^{(2)}$ | | 0.1 | | | V/ns |
| Clock Fall Time peak to peak | $t_{CHCL}^{(2)}$ | | 0.1 | | | V/ns |
| \overline{CS} Active Setup Time relative to Clock | t_{SLCH} | t_{CSS} | 5 | | | ns |
| \overline{CS} Not Active Hold Time relative to Clock | t_{CHSL} | | 5 | | | ns |
| Data In Setup Time | t_{DVCH} | t_{DSU} | 2 | | | ns |
| Data In Hold Time | t_{CHDX} | t_{DH} | 5 | | | ns |
| \overline{CS} Active Hold Time relative to Clock | t_{CHSH} | | 5 | | | ns |
| \overline{CS} Not Active Setup Time relative to Clock | t_{SHCH} | | 5 | | | ns |
| \overline{CS} Deselect Time (for Read instructions/ Write, Erase and Program instructions) | t_{SHSL} | t_{CSH} | 100 | | | ns |
| Output Disable Time | $t_{SHQZ}^{(2)}$ | t_{DIS} | | | 7 | ns |
| Clock Low to Output Valid | t_{CLQV} | t_{V1} | | | 7 | ns |
| Clock Low to Output Valid (Except Main Read) ⁽³⁾ | t_{CLQV} | t_{V2} | | | 8 | ns |

| | | | | | | |
|---|----------------------|-----|-----|------|-----|---------------|
| Output Hold Time | tCLQX | tHO | 1.5 | | | ns |
| $\overline{\text{HOLD}}$ Active Setup Time relative to Clock | tHLCH | | 5 | | | ns |
| $\overline{\text{HOLD}}$ Active Hold Time relative to Clock | tCHHH | | 5 | | | ns |
| $\overline{\text{HOLD}}$ Not Active Setup Time relative to Clock | tHHCH | | 5 | | | ns |
| $\overline{\text{HOLD}}$ Not Active Hold Time relative to Clock | tCHHL | | 5 | | | ns |
| $\overline{\text{HOLD}}$ to Output Low-Z | tHHQX ⁽²⁾ | tLZ | | | 7 | ns |
| $\overline{\text{HOLD}}$ to Output High-Z | tHLQZ ⁽²⁾ | tHZ | | | 12 | ns |
| Write Protect Setup Time Before $\overline{\text{CS}}$ Low | tWHSL ⁽⁴⁾ | | 20 | | | ns |
| Write Protect Setup Time After $\overline{\text{CS}}$ High | tSHWL ⁽⁴⁾ | | 100 | | | ns |
| $\overline{\text{CS}}$ High to Power Down Mode | tDP ⁽²⁾ | | | | 3 | μs |
| $\overline{\text{CS}}$ High to Standby Mode without Electronic Signature Read | tRES1 ⁽²⁾ | | | | 3 | μs |
| $\overline{\text{CS}}$ High to Standby Mode with Electronic Signature Read | tRES2 ⁽²⁾ | | | | 1.8 | μs |
| $\overline{\text{CS}}$ High to next Instruction after Suspend | tSUS ⁽²⁾ | | | | 30 | μs |
| $\overline{\text{CS}}$ High to next Instruction after Reset | tRST ⁽²⁾ | | | | 30 | μs |
| Write Status Register Time | tw | | | 10 | 15 | ms |
| Byte Program Time | tBP | | | 10 | 150 | μs |
| Page Program Time | tPP | | | 0.6 | 5 | ms |
| Page Program Time (ACC = 9V) | tEP | | | 0.3 | 3 | ms |
| Block Erase Time(4KB) | tSE | | | 0.06 | 0.4 | s |
| Block Erase Time(32KB) | tBE1 | | | 0.20 | 1.5 | s |
| Block Erase Time(64KB) | tBE2 | | | 0.35 | 2 | s |
| Chip Erase Time | tCE | | | 20 | 80 | s |

Notes:

1. Clock high + Clock low must be less than or equal to 1/fc.
2. Value guaranteed by design and/or characterization, not 100% tested in production.
3. Contains: Read Status Register-1,2/ Read Manufacturer/Device ID, Dual, Quad/ Read JEDEC ID/ Read Security Register/ Read Serial Flash Discovery Parameter.
4. Only applicable as a constraint for a Write Status Register instruction when Sector Protect Bit is set to 1.
5. Commercial temperature only applies to Fast Read (FR). Industrial temperature applies to all other parameters.

8.9 Input Timing

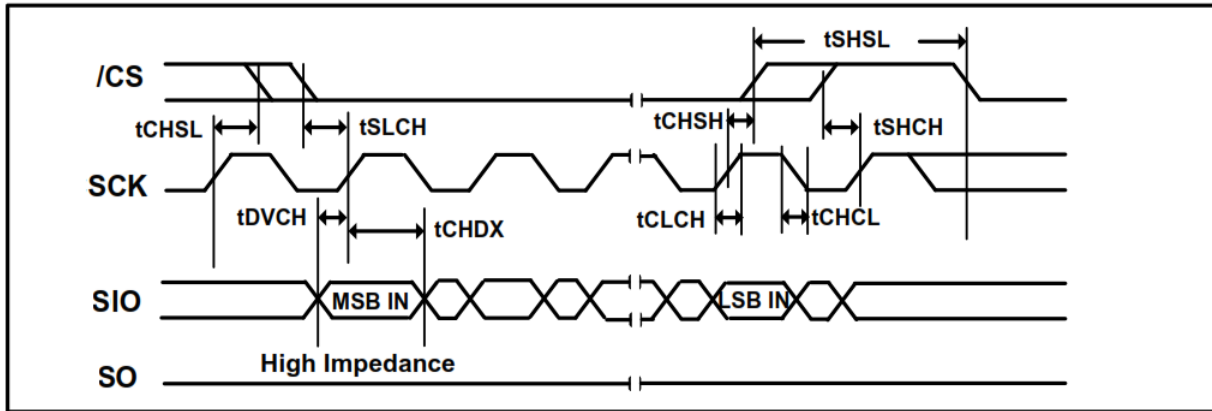

8.10 Output Timing

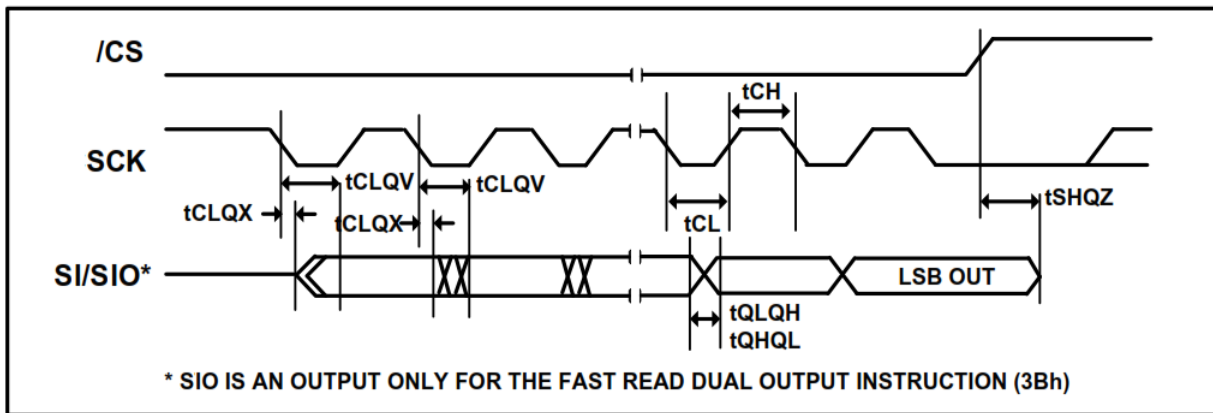

8.11 Hold Timing

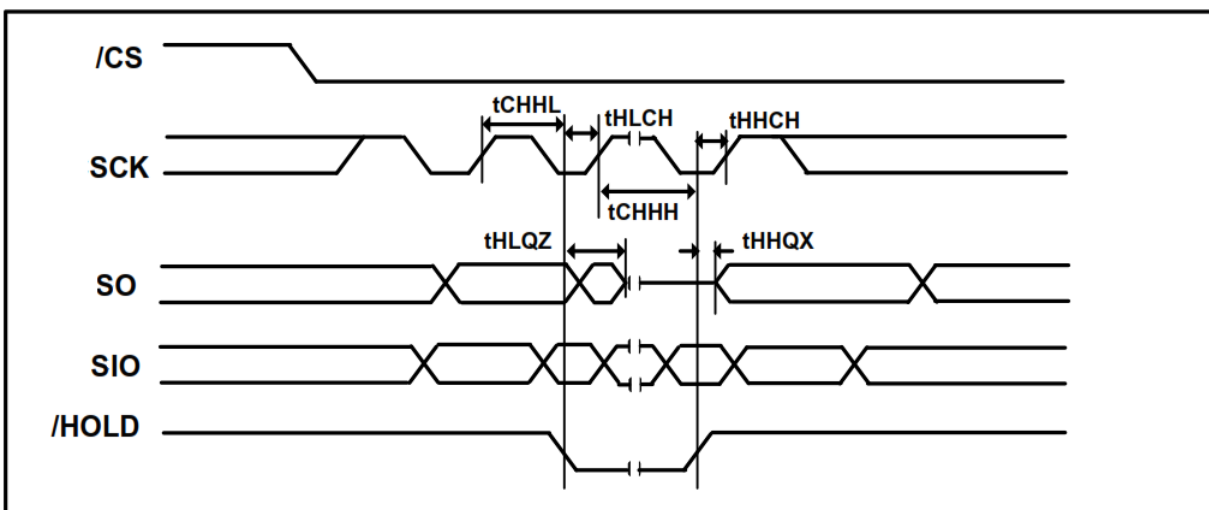

9. Ordering Information

9.1 Ordering Code Detail

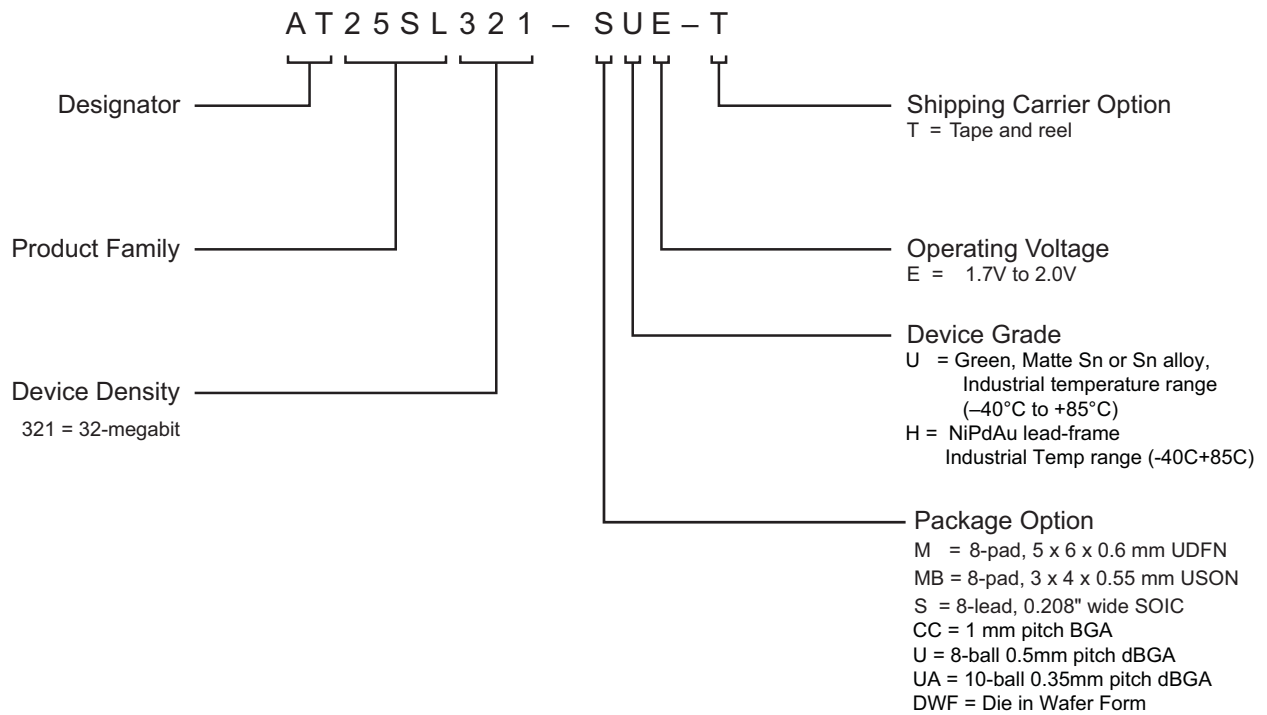

| Ordering Code ⁽¹⁾ | Package | Lead Finish | Operating Voltage | Max. Freq. (MHz) | Operation Range |
|---------------------------------|----------|-------------|-------------------|------------------------|---|
| AT25SL321-MHE-T | 8MA1 | NiPdAu | 1.7V-2.0V | 104 MHz ⁽²⁾ | -40°C to 85°C (Industrial Temperature Range) |
| AT25SL321-MBUE-T | 8MA2 | | | | |
| AT25SL321-SUE-T | 8S4 | SnAgCu | | | |
| AT25SL321-CCUE-T | 24CC | | | | |
| AT25SL321-UUE-T ⁽³⁾ | 8-WLCSP | | | | |
| AT25SL321-UAUE-T ⁽³⁾ | 10-WLCSP | | | | |
| AT25SL321-DWF ⁽³⁾ | DWF | | | | |

- The shipping carrier option code is not marked on the devices.
- Contact Adesto for availability of 133MHz operating frequency.
- Contact Adesto for mechanical drawing or sales information.

| Package Type | |
|--------------|--|
| 8S4 | 8-lead, 0.208" Wide, Plastic Gull Wing Small Outline Package (EIAJ SOIC) |
| 8MA1 | 8-pad (5 x 6 x 0.6 mm body), Thermally Enhanced Plastic Ultra-Thin Dual Flat No-lead (UDFN) |
| 8MA2 | 8-pad (3 x 4 x 0.55 mm body), Thermally Enhanced Plastic Ultra-Thin Small Outline No-lead (USON) |

| Package Type | |
|-----------------|---|
| 24CC | 24-ball, 1 mm pitch, Ball Grid Array (BGA) |
| 8-WLCSP | 8-ball, 0.5mm pitch, die Ball Grid Array (dBGA) |
| 10-WLCSP | 10-ball, 0.35mm pitch, die Ball Grid Array (dBGA) |
| DWF | Die in Wafer Form |

10. Packaging Information–

10.1 8S4 – 8-lead, .208" EIAJ SOIC

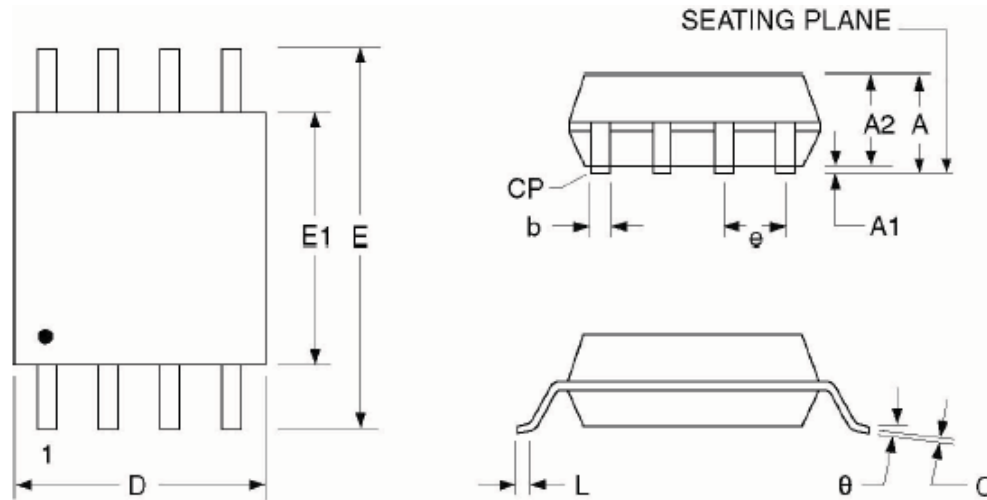

| SYMBOL | MILLIMETERS | | | INCHES | | |
|--------|-------------|------|------|-----------|-------|-------|
| | MIN | NOM | MAX | MIN | NOM | MAX |
| A | 1.75 | 1.95 | 2.16 | 0.069 | 0.077 | 0.085 |
| A1 | 0.05 | 0.15 | 0.25 | 0.002 | 0.006 | 0.010 |
| A2 | 1.70 | 1.80 | 1.91 | 0.067 | 0.071 | 0.075 |
| B | 0.35 | 0.42 | 0.48 | 0.014 | 0.017 | 0.019 |
| C | 0.19 | 0.20 | 0.25 | 0.007 | 0.008 | 0.010 |
| D | 5.18 | 5.28 | 5.38 | 0.204 | 0.208 | 0.212 |
| E | 7.70 | 7.90 | 8.10 | 0.303 | 0.311 | 0.319 |
| E1 | 5.18 | 5.28 | 5.38 | 0.204 | 0.208 | 0.212 |
| e | 1.27 BSC | | | 0.050 BSC | | |
| L | 0.50 | 0.65 | 0.80 | 0.020 | 0.026 | 0.031 |
| θ | 0° | - | 8° | 0° | - | 8° |
| Y | - | - | 0.10 | - | - | 0.004 |

6/13/17

| | | | | |
|---|--|-----|-------------|------|
|  Package Drawing Contact: contact@adestotech.com | TITLE 8S4, 8-lead, 0.208" Body, Plastic Small Outline Package (EIAJ) | GPC | DRAWING NO. | REV. |
| | | STN | 8S4 | B |

10.2 8MA1 – UDFN

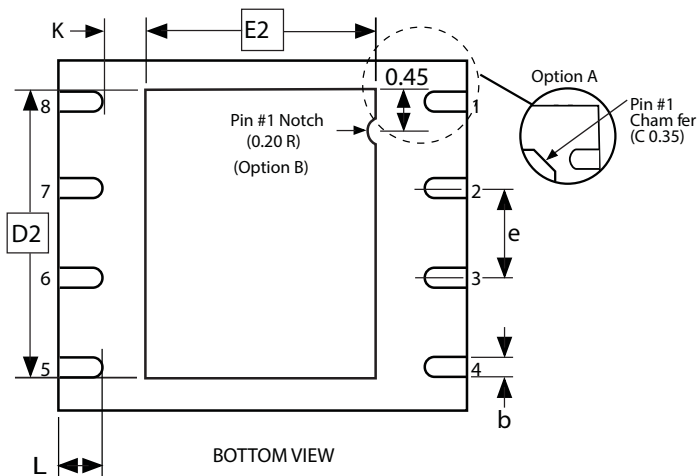
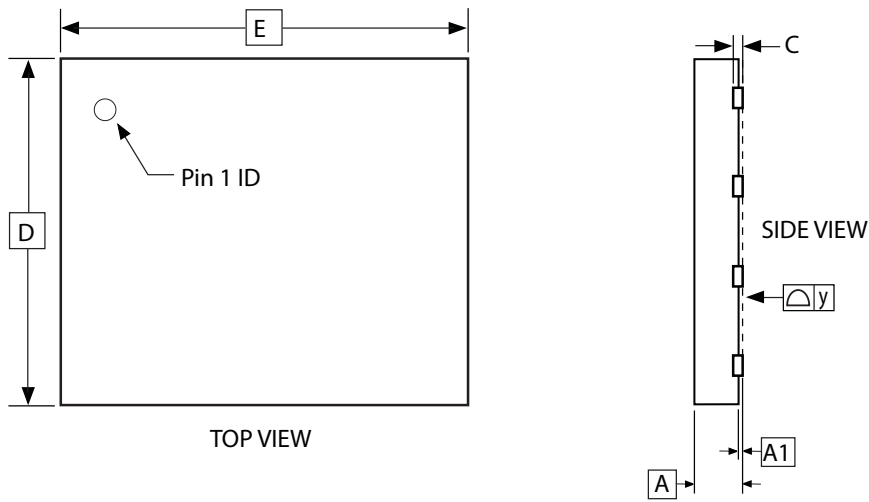

COMMON DIMENSIONS
(Unit of Measure = mm)

| SYMBOL | MIN | NOM | MAX | NOTE |
|--------|-----------|------|------|------|
| A | 0.45 | 0.55 | 0.60 | |
| A1 | 0.00 | 0.02 | 0.05 | |
| b | 0.35 | 0.40 | 0.48 | |
| C | 0.152 REF | | | |
| D | 4.90 | 5.00 | 5.10 | |
| D2 | 3.80 | 4.00 | 4.20 | |
| E | 5.90 | 6.00 | 6.10 | |
| E2 | 3.20 | 3.40 | 3.60 | |
| e | 1.27 | | | |
| L | 0.50 | 0.60 | 0.75 | |
| y | 0.00 | - | 0.08 | |
| K | 0.20 | - | - | |

Notes: 1. This package conforms to JEDEC reference MO-229, Saw Singulation.
2. The terminal #1 ID is a Laser-marked Feature.

4/15/08

| | | | | |
|--|---|-----|-------------|------|
|  Package Drawing Contact: contact@adestotech.com | TITLE | GPC | DRAWING NO. | REV. |
| | 8MA1, 8-pad (5 x 6 x 0.6 mm Body), Thermally Enhanced Plastic Ultra Thin Dual Flat No Lead Package (UDFN) | YFG | 8MA1 | D |

10.3 8MA2 – USON

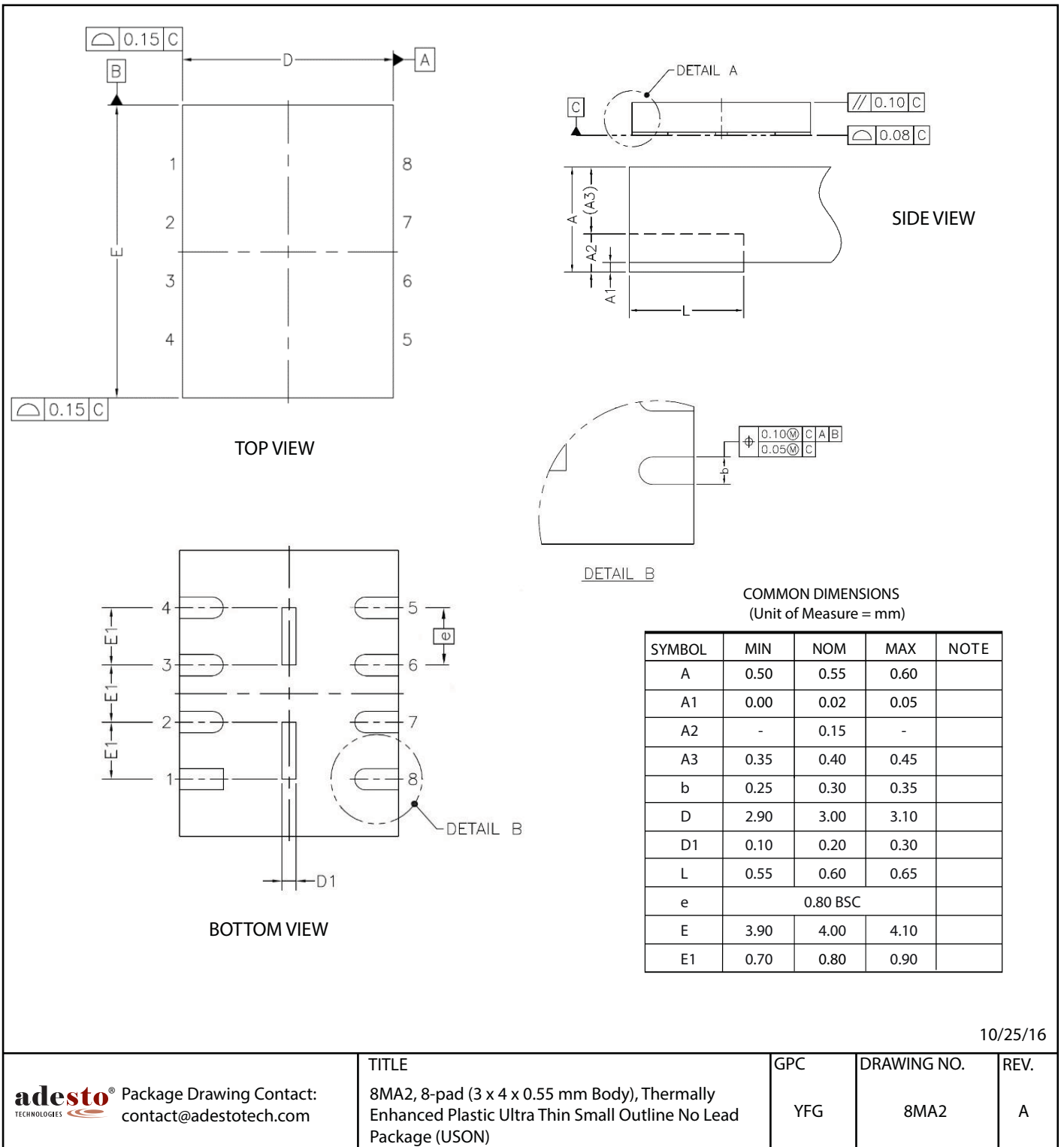

10.4 24CC — 24-ball BGA

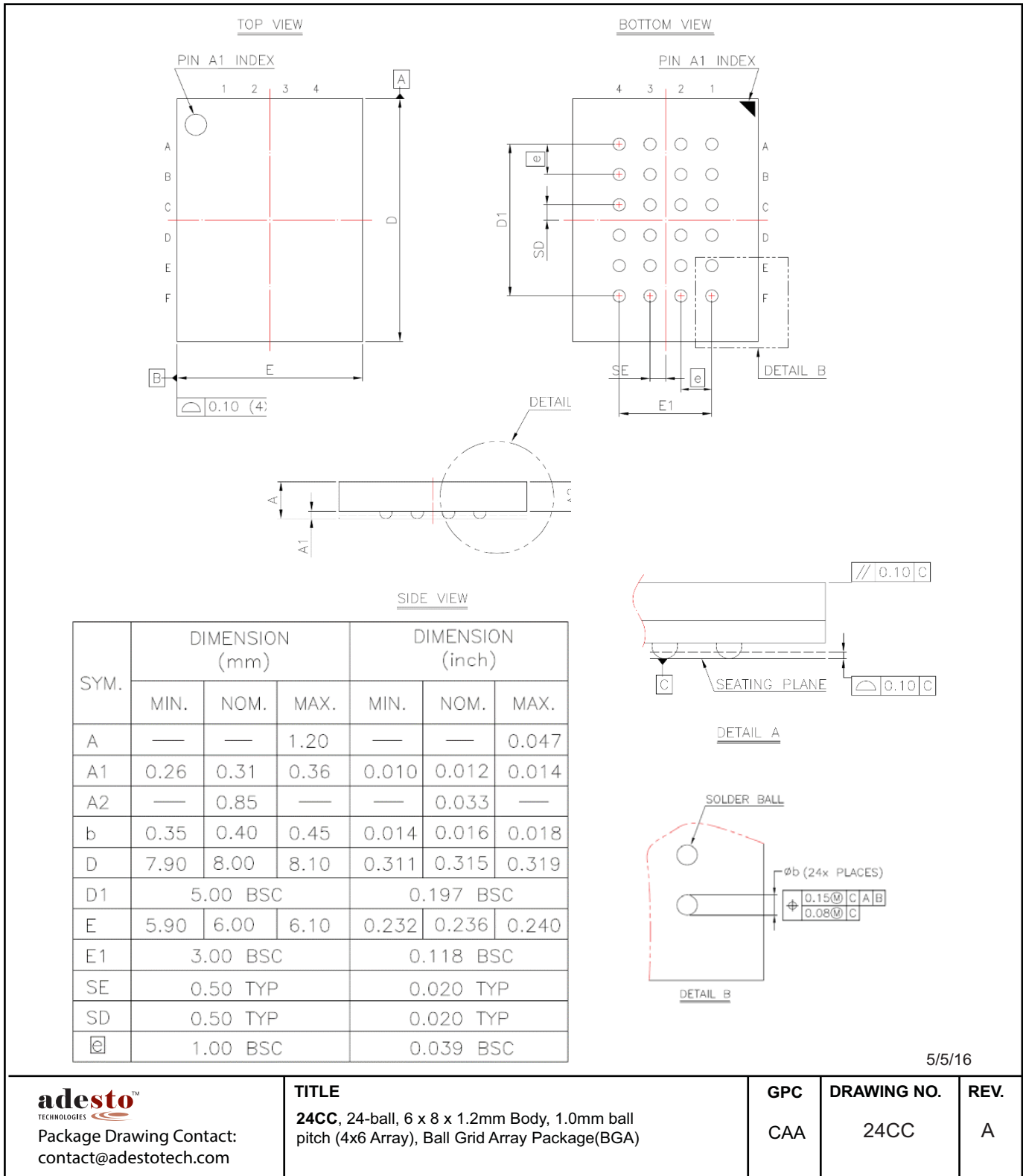

10.5 8-WLCSP — die Ball Grid Array

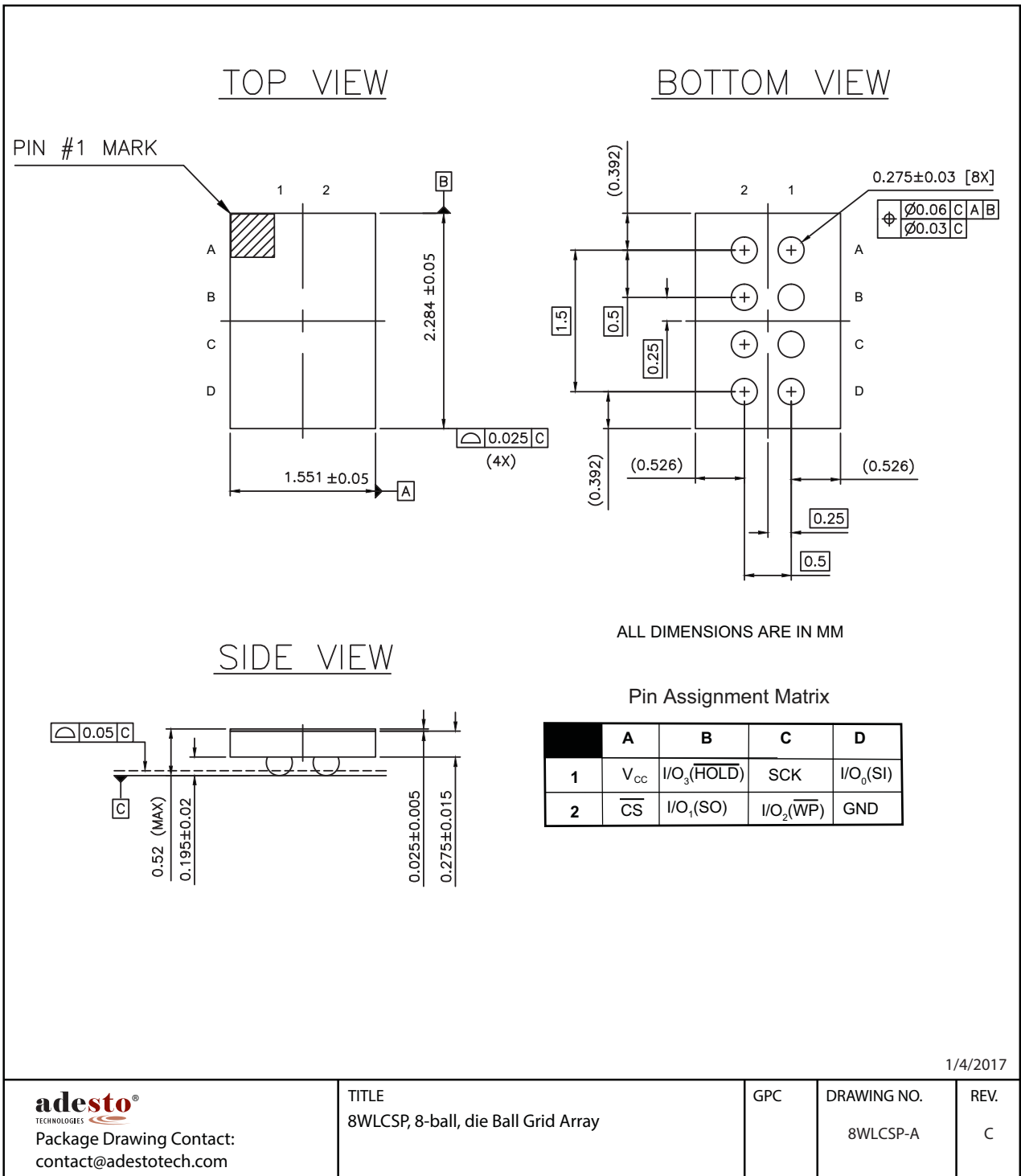

10.6 10-WLCSP — die Ball Grid Array

Package Drawing TBC (To Be Confirmed - Contact Adesto for more information)

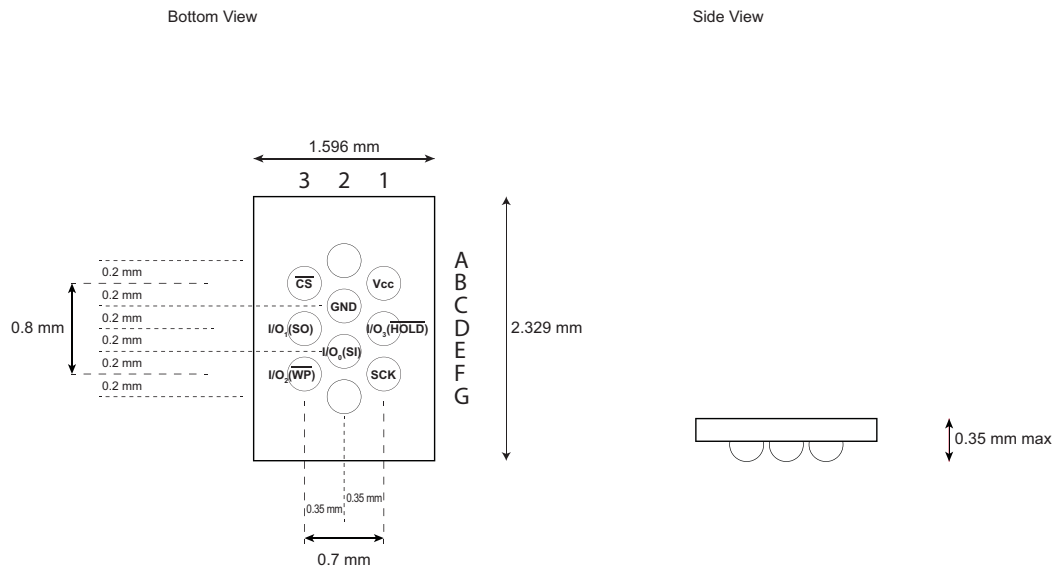

Unmarked balls are NC
Final package outline drawing to be confirmed

11. Revision History

| Revision Level – Release Date | History |
|-------------------------------|--|
| A – June 2016 | Initial release of AT25SL321A datasheet. |
| B – August 2016 | Updated 8-WLCSP package outline drawing. Added 10-WLCSP package. Updated voltage range. Removed Sector and Block Protect descriptions. Removed Status Register Memory Protection tables. Updated tCSH specification. |
| C – October 2016 | Updated UDFN package drawing and dimensions. Added USON package drawing and dimensions. Updated command description for 50h. Updated SFDP tables. |
| D – November 2016 | Updated SFDP tables (to version 1.6). |
| E – February 2017 | Updated Note 1 on Table 8.1. |
| F – March 2017 | Updated document status from Advanced to Complete. |



Corporate Office

California | USA

Adesto Headquarters

3600 Peterson Way

Santa Clara, CA 95054

Phone: (+1) 408.400.0578

Email: contact@adestotech.com

© 2017 Adesto Technologies. All rights reserved. / Rev.: DS-25SL321-112F-3/2017

Disclaimer: Adesto Technologies Corporation makes no warranty for the use of its products, other than those expressly contained in the Company's standard warranty which is detailed in Adesto's Terms and Conditions located on the Company's web site. The Company assumes no responsibility for any errors which may appear in this document, reserves the right to change devices or specifications detailed herein at any time without notice, and does not make any commitment to update the information contained herein. No licenses to patents or other intellectual property of Adesto are granted by the Company in connection with the sale of Adesto products, expressly or by implication. Adesto's products are not authorized for use as critical components in life support devices or systems.

Mouser Electronics

Authorized Distributor

Click to View Pricing, Inventory, Delivery & Lifecycle Information:

[Dialog Semiconductor:](#)

[AT25SL321-MBUE-T](#) [AT25SL321-MHE-T](#) [AT25SL321-SUE-T](#) [AT25SL321-UUE-T](#)