

MCU discovery board for SPC5 Chorus 1M automotive microcontroller

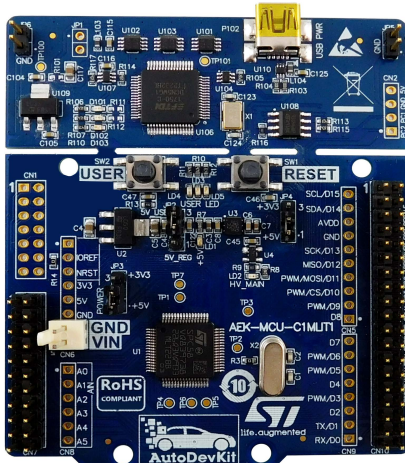

Features

- [SPC582B60E1](#) microcontroller: 32-bit z2 core at 80 Mhz CPU, 32-bit Power Architecture® technology CPU, 1 MB Code Flash in eQFP64 package
- On-board USB-JTAG PLS debugger and dedicated optional connector to plug a standalone JTAG debugger
- Extension headers for all the device pins for fast prototyping
- Mini-B USB port
- One user push button and one RESET button
- 3 LEDs for user purposes
- 3 integrated programmers/debuggers
- 1 Reset and 1 Power LED (+5 V)
- 40 MHz Crystal
- RoHS and WEEE compliant
- Part of the AutoDevKit™ initiative

Description

The [AEK-MCU-C1MLIT1](#) board exploits the functionality of [SPC582B60E1](#) Power Architecture® microcontrollers with full access to CPUs, I/O signals and peripherals.

The [SPC58 2B Line](#) MCUs are designed to address automotive vehicle body, gateway and industrial oriented applications.

Free ready-to-run application firmware examples are available in [SPC5-STUDIO](#) software with [AutoDevKit](#) plug-in ([STSW-AUTODEVKIT](#)) to support quick evaluation and development.

Product summary	
MCU discovery board for SPC5 Chorus 1M automotive microcontroller	AEK-MCU-C1MLIT1
32-bit power architecture MCU for automotive general purpose applications - Chorus family	SPC582B60E1
Code generator, quick resource configurator and Eclipse development environment for SPC5 MCUs	SPC5-STUDIO
Applications	Automotive Gateway Body Control Module

1 System requirements, HW and SW resources

- Hardware requirements:
 - Windows PC
 - USB cable: Type A to mini-B
- Software requirements:
 - [SPC5-STUDIO](#) for low-level drivers, code generation, system and peripherals configuration, pin configuration and firmware development
 - PLS UDE for MCU programming and debugging
 - [AutoDevKit](#) plug-in for cross-platform functional board components

Figure 2. AEK-MCU-C1MLIT1 circuit schematic (2 of 4)

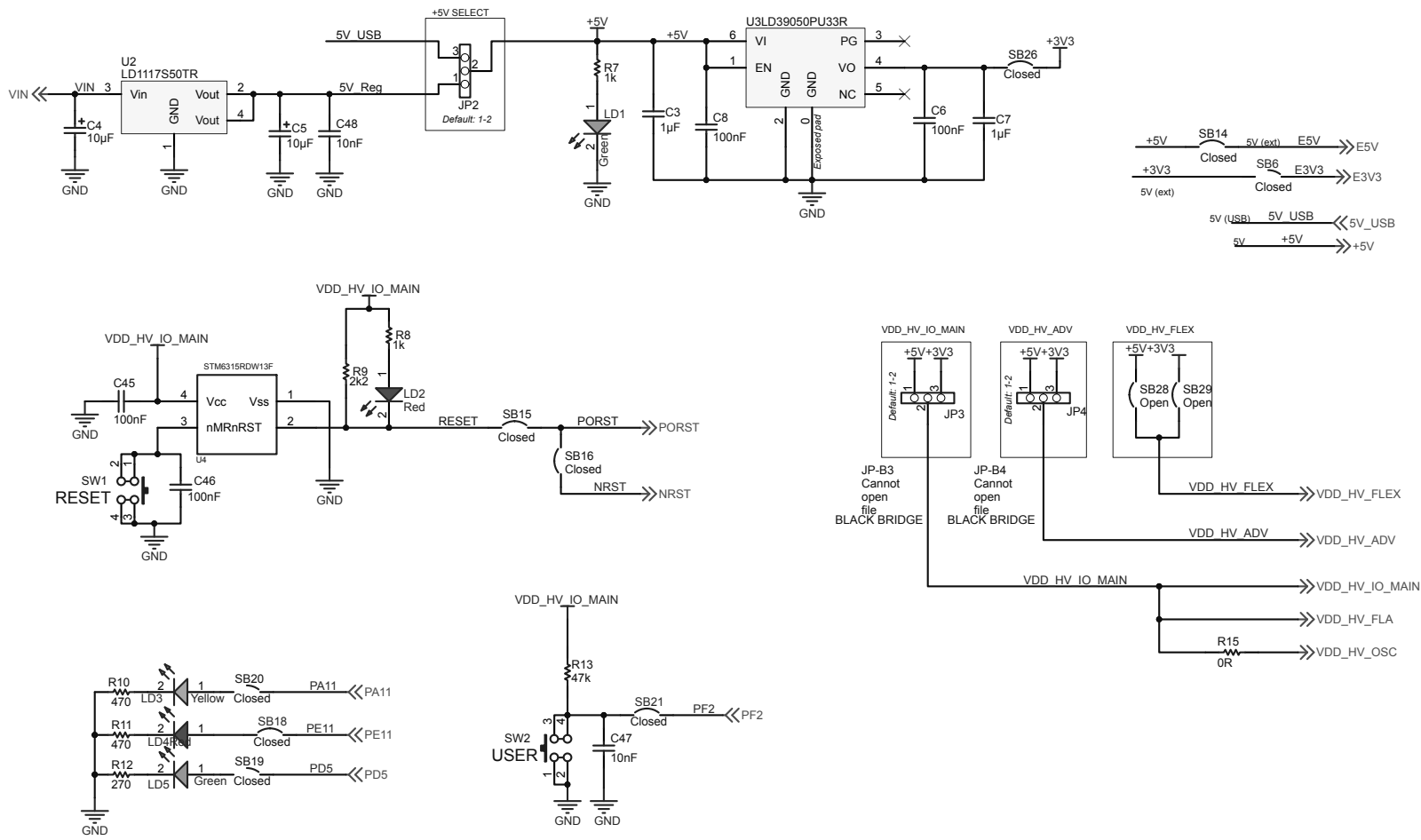

Figure 3. AEK-MCU-C1MLIT1 circuit schematic (3 of 4)

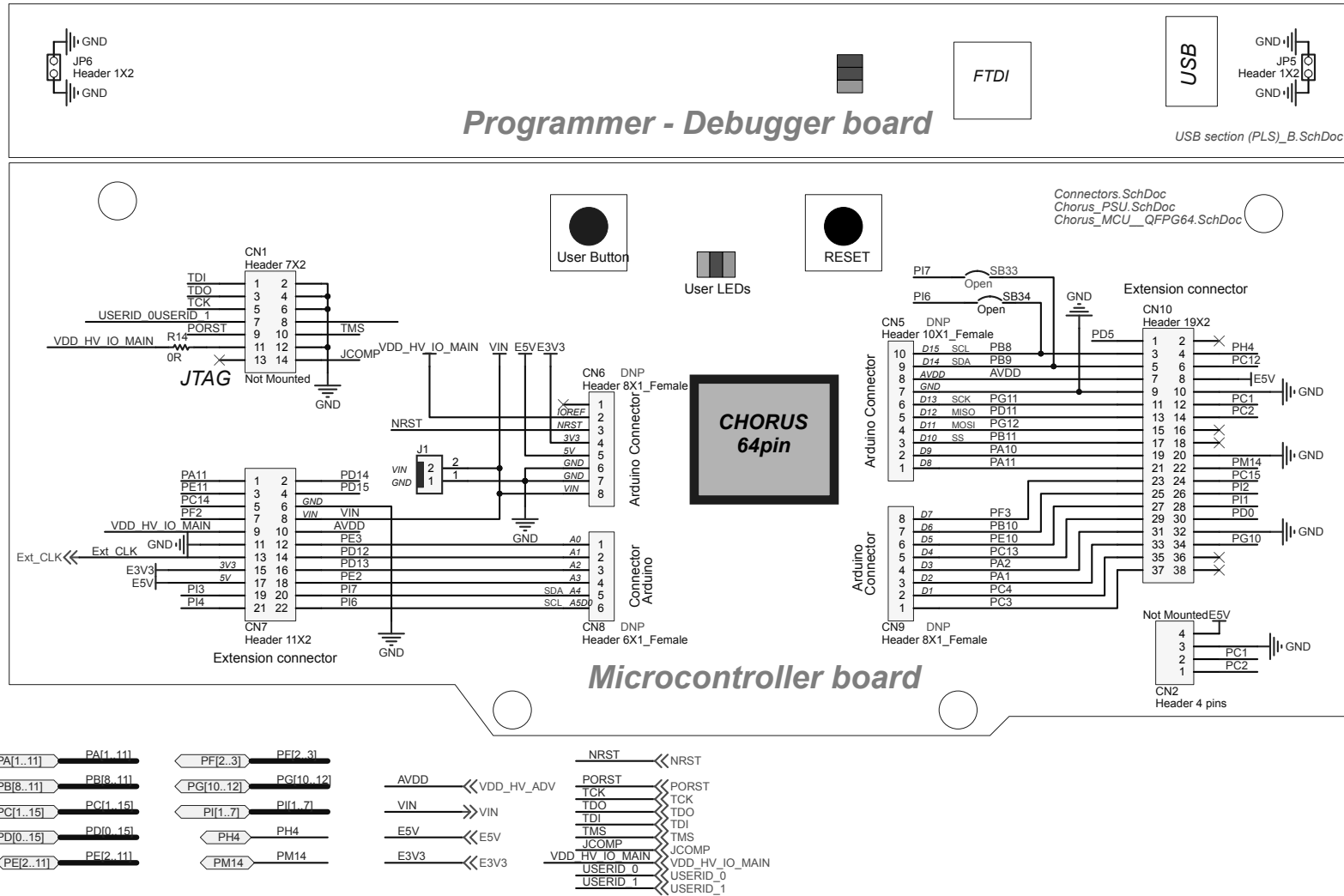
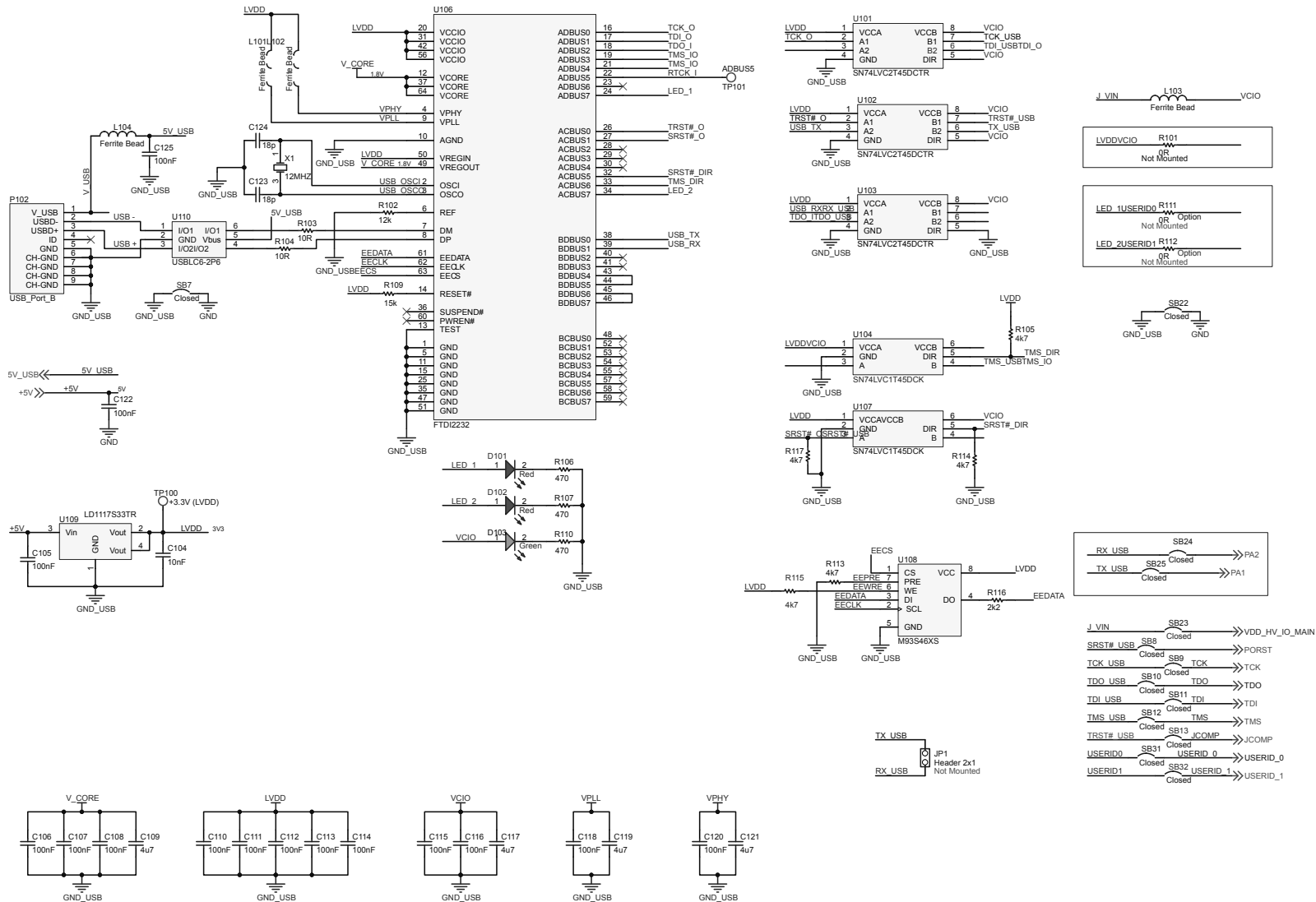

Figure 4. AEK-MCU-C1MLIT1 circuit schematic (4 of 4)



Revision history

Table 1. Document revision history

Date	Version	Changes
12-Feb-2020	1	Initial release.

IMPORTANT NOTICE – PLEASE READ CAREFULLY

STMicroelectronics NV and its subsidiaries (“ST”) reserve the right to make changes, corrections, enhancements, modifications, and improvements to ST products and/or to this document at any time without notice. Purchasers should obtain the latest relevant information on ST products before placing orders. ST products are sold pursuant to ST’s terms and conditions of sale in place at the time of order acknowledgement.

Purchasers are solely responsible for the choice, selection, and use of ST products and ST assumes no liability for application assistance or the design of Purchasers’ products.

No license, express or implied, to any intellectual property right is granted by ST herein.

Resale of ST products with provisions different from the information set forth herein shall void any warranty granted by ST for such product.

ST and the ST logo are trademarks of ST. For additional information about ST trademarks, please refer to www.st.com/trademarks. All other product or service names are the property of their respective owners.

Information in this document supersedes and replaces information previously supplied in any prior versions of this document.

© 2020 STMicroelectronics – All rights reserved

Mouser Electronics

Authorized Distributor

Click to View Pricing, Inventory, Delivery & Lifecycle Information:

[STMicroelectronics:](#)

[AEK-MCU-C1MLIT1](#)