

88W8977_SDS

2.4 GHz/5 GHz Dual-band 1x1 Wi-Fi 4 and Bluetooth 5.2 Combo SoC

Rev. 3 — 13 May 2021

Product short data sheet

1 Product overview

The 88W8977 System-on-Chip (SoC) is a highly integrated single-chip solution that incorporates both Wi-Fi® (2.4/5 GHz) and Bluetooth® technology. The System-on-Chip (SoC) provides both simultaneous and independent operation of the following:

- IEEE 802.11n compliant, 1x1 spatial stream with data rates up to MCS7 (150 Mbps)
- Bluetooth 5.2 (includes Bluetooth Low Energy (LE))

The SoC also provides 3-way coexistence for Wi-Fi, Bluetooth, and ZigBee operation, and indoor location and navigation (802.11mc).

The internal coexistence arbitration and a Mobile Wireless Systems (MWS) serial transport interface provide the functionality for connecting an external Long Term Evolution (LTE) or ZigBee device. The device also supports a coexistence interface for co-located Bluetooth/Wi-Fi device arbitration.

For security, the device supports high performance 802.11i security standards through the implementation of the Advanced Encryption Standard (AES)/Counter Mode CBC-MAC Protocol (CCMP), Wired Equivalent Privacy (WEP) with Temporal Key Integrity Protocol (TKIP), AES/Cipher-Based Message Authentication Code (CMAC), WPA (AES), and Wi-Fi Authentication and Privacy Infrastructure (WAPI) security mechanisms.

For video, voice, and multimedia applications, 802.11e Quality of Service (QoS) is supported. The device also features 802.11h Dynamic Frequency Selection (DFS) for detecting radar pulses when operating in the 5 GHz range.

Host interfaces include SDIO 3.0 and high-speed UART interfaces for connecting Wi-Fi and Bluetooth technologies to the host processor.

The device is available in QFN and eWLP package options.

[Figure 1](#) shows the functional block diagram of the device.



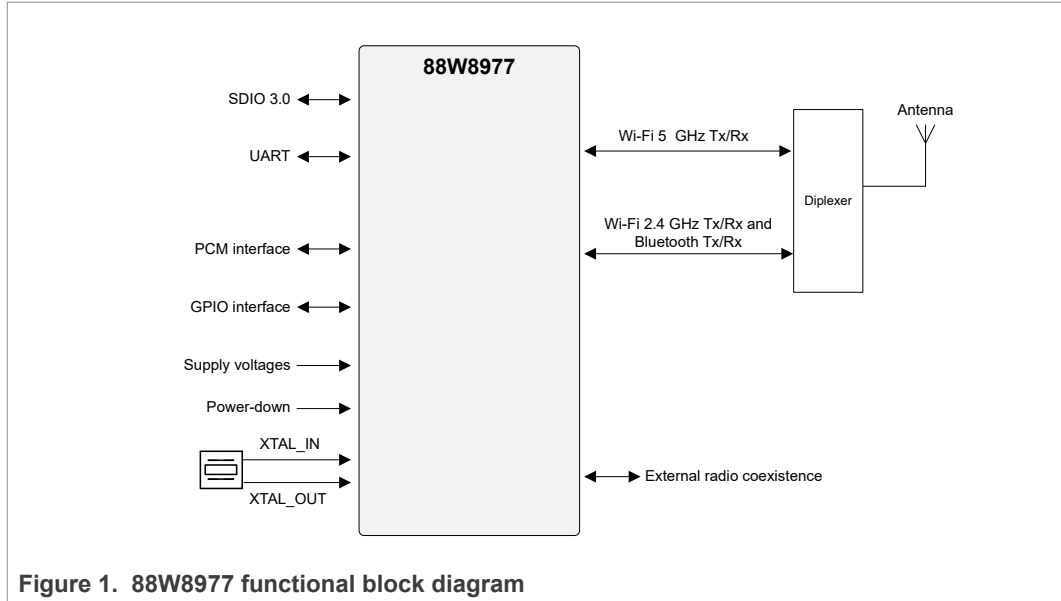

1.1 Applications

Smart home applications:

- Wireless home audio and video entertainment systems
- Wearables
- Internet of Things (IoT) gateways
- Mobile routers

Mobile applications:

- Wi-Fi and Bluetooth enabled smart phones and tablets
- Personal computing systems including notebooks and ultrabooks

1.2 Wi-Fi key features

- Support 802.11 a/b/g/n
- Dual band: 2.4 GHz and 5 GHz
- Single stream 802.11n with 20 MHz and 40 MHz channels
- Up to MCS7 data rates (150 Mbps)
- Support 802.11mc for location
- Security: support WPA/WPA2 mixed mode, WPA2 and WPA3 security standards

1.3 Bluetooth key features

- Bluetooth 5.2 support
- Direction Finding—Connection-oriented Angle of Arrival (AoA)
- PCM audio interface
- Security: AES

1.4 Host interfaces

Wi-Fi and Bluetooth host interface options

Wi-Fi	Bluetooth
SDIO 3.0	UART
SDIO 3.0	SDIO 3.0

1.5 Operating characteristics

- Supply voltage: 2.2V, 1.8V, and 1.05V
- Operating temperature
 - Extended: -30 to 85°C
 - Industrial: -40 to 85°C

1.6 General features

- Package options
 - 68-pin QFN (8 mm x 8 mm)
 - 74-bump eWLP (4.674 mm x 3.46 mm)
- Simultaneous Wi-Fi and Bluetooth operation, including Bluetooth Low Energy (LE)
- Dynamic Rapid Channel Switching (DRCS) for simultaneous operation in 2.4 GHz and 5 GHz bands
- Power saving features
 - Efficient power management system
 - On-chip LDO for 1.05V generation from 1.8V supply
 - Sleep and standby modes
 - Deep-sleep mode
- Independent ARM-based Wi-Fi and Bluetooth CPUs
- Independent two-channel Direct Memory Access (DMA)
- Memory:
 - Internal SRAM
 - Boot ROM
 - OTP memory to store the MAC address and calibration data
- Peripheral Interface
 - General-Purpose I/O (GPIO) interface

1.7 Internal block diagram

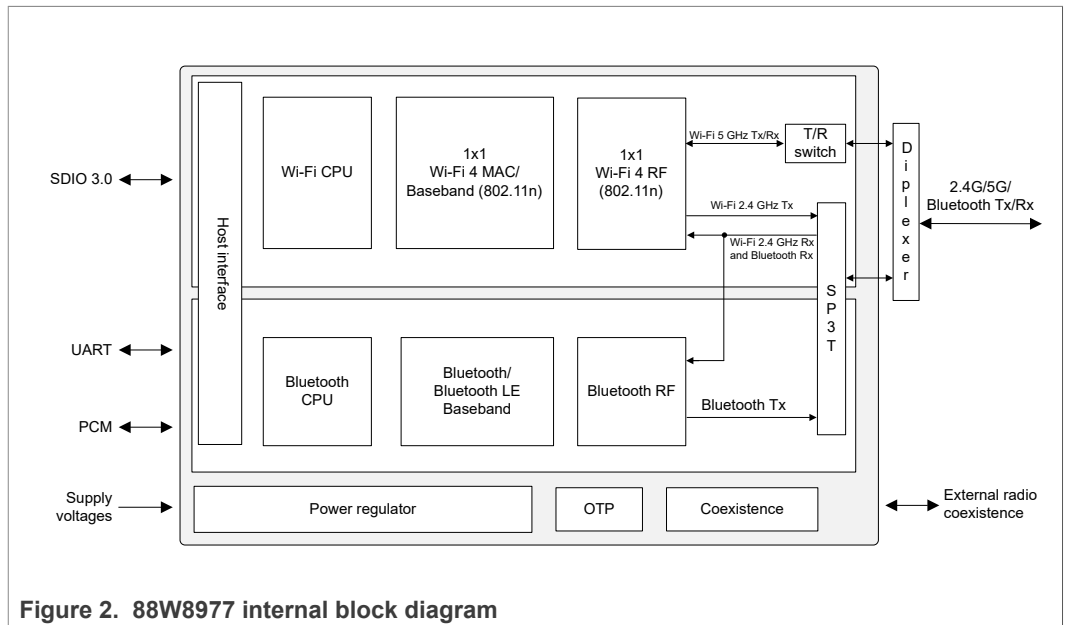

Figure 2. 88W8977 internal block diagram

2 Ordering information

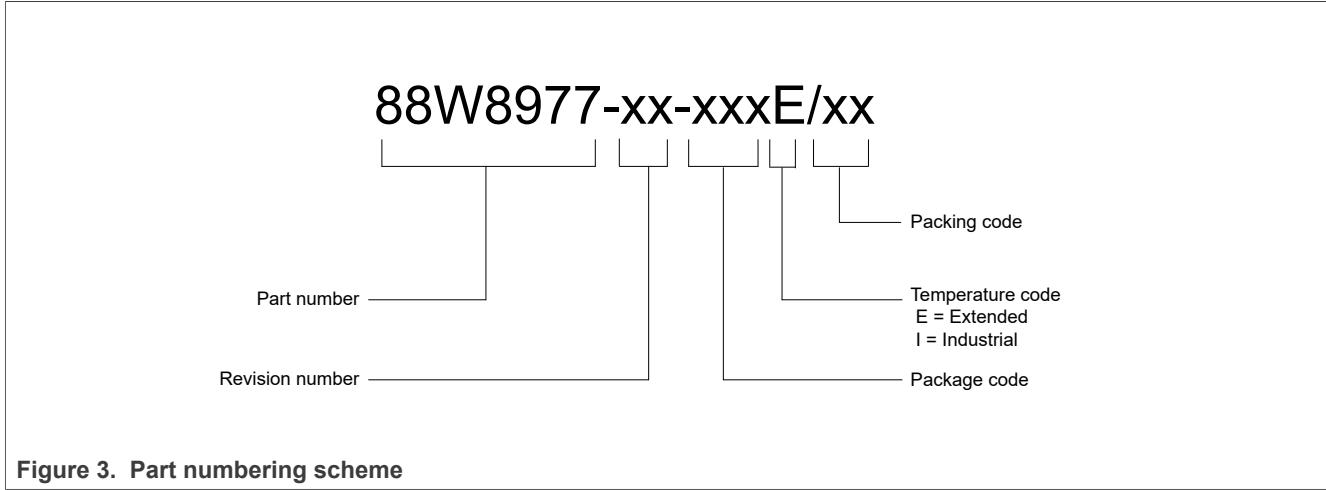

Table 1. Part Order Codes

Part Order Code	Package Type	Packing
88W8977-A1-NMVE/AK	68-pin MQFN - 8 x 8 x 0.85 mm, with 0.4 mm pitch	Tray
88W8977-A1-NMVE/AZ	68-pin MQFN - 8 x 8 x 0.85 mm, with 0.4 mm pitch	Tape and Reel
88W8977-A1-NMVI/AK	68-pin MQFN - 8 x 8 x 0.85 mm, with 0.4 mm pitch	Tray
88W8977-A1-NMVI/AZ	68-pin MQFN - 8 x 8 x 0.85 mm, with 0.4 mm pitch	Tape and Reel
88W8977-A1-EADE/AZ	74-bump eWLP - 4.674 x 3.46 x 0.76 mm, with 0.4 mm pitch	Tape and Reel

3 Wi-Fi subsystem

3.1 IEEE 802.11 standards

- 802.11b data rates of 1 and 2 Mbps
- 802.11b data rates of 5.5 and 11 Mbps
- 802.11a/g data rates 6, 9, 12, 18, 24, 36, 48, and 54 Mbps for multimedia content transmission
- 802.11g/b performance enhancements
- 802.11n with maximum data rates up to 72 Mbps (20 MHz channel), 150 Mbps (40 MHz channel)
- 802.11d international roaming
- 802.11e quality of service
- 802.11h transmit power control
- 802.11h DFS radar pulse detection
- 802.11i enhanced security
- 802.11k radio resource measurement
- 802.11mc precise indoor location and navigation
- 802.11n block acknowledgement extension
- 802.11r fast hand-off for AP roaming
- 802.11u Hotspot 2.0 (STA mode only)
- 802.11v TIM frame transmission/reception
- 802.11w protected management frames
- Fully supports clients (stations) implementing IEEE Power Save mode

3.2 Wi-Fi MAC

- Simultaneous peer-to-peer and Infrastructure Modes
- RTS/CTS for operation under DCF
- Hardware filtering of 32 multicast addresses and duplicate frame detection for up to 32 unicast addresses
- On-chip transmit and receive FIFO for maximum throughput
- Open System and Shared Key Authentication services
- A-MPDU Rx (de-aggregation) and transmit (aggregation)
- 20/40 MHz coexistence
- Reduced Inter-Frame Spacing (RIFS) receive
- Management information base counters
- Radio resource measurement counters
- Quality of service queues
- Block acknowledgement extension
- Dynamic frequency selection
- TIM frame transmission/reception
- Multiple-BSS/Station
- Transmit rate adaptation
- Transmit power control
- Long and short preamble generation on a frame-by-frame basis for 802.11b frames
- Mobile hotspot

3.3 Wi-Fi baseband

- 802.11n 1x1 SISO
- Backward compatibility with legacy 802.11a/g/b technology
- 2.4 GHz Wi-Fi and Bluetooth share LNA for receive operation
- PHY data rates up to 150 Mbps
- 20 MHz bandwidth/channel, 40 MHz bandwidth/channel, upper/lower 20 MHz packets in 40 MHz channel, 20 MHz duplicate legacy packets in 40 MHz channel mode operation
- Modulation and Coding Scheme (MCS)—MCS0~7
- Dynamic frequency selection (radar detection)
 - Enhanced radar detection for long and short pulse radar
 - Enhanced AGC scheme for DFS channel
 - Compliance with Japan DFS requirements for W53 and W56
- Radio resource measurement
- Optional 802.11n SISO features:
 - 20/40 MHz coexistence
 - One spatial stream STBC reception
 - Short guard interval
 - RIFS on receive path for 802.11n packets
 - 802.11n greenfield Tx/Rx
- Wi-Fi indoor locationing (802.11mc)
- Power save features

3.4 Wi-Fi radio

- Integrated direct-conversion radio
- 20 and 40 MHz channel bandwidths
- Shared Wi-Fi/Bluetooth receive input scheme for 2.4 GHz band

Wi-Fi receive path

- Direct conversion architecture eliminates need for external SAW filter
- On-chip gain selectable LNA with optimized noise figure and power consumption
- High dynamic range AGC function in receive mode

Wi-Fi transmit path

- Internal PA with power control
- Optimized transmit gain distribution for linearity and noise performance

Wi-Fi local oscillator

- Fine channel step

3.5 Wi-Fi encryption

- WEP 64- and 128-bit encryption with hardware TKIP processing (WPA)
- AES/CCMP hardware implementation as part of the 802.11i security standard (WPA2)
- Enhanced AES engine performance
- AES/Cipher-based Message Authentication Code (CMAC) as part of the 802.11w security standard
- Simultaneous Authentication of Equals (SAE) WPA3
- WLAN Authentication and Privacy Infrastructure (WAPI)

3.6 Wi-Fi host interfaces

- SDIO 3.0

4 Bluetooth subsystem

4.1 Bluetooth

- Bluetooth 5.2
- Bluetooth Class 2
- Bluetooth Class 1
- Single-ended, shared Tx/Rx path for Wi-Fi/Bluetooth
- Shared LNA for Wi-Fi/Bluetooth
- PCM interface for voice applications
- Baseband and radio BDR and EDR packet types—1 Mbps (GFSK), 2 Mbps ($\pi/4$ -DQPSK), and 3 Mbps (8DPSK)
- Fully functional Bluetooth baseband—AFH, forward error correction, header error control, access code correlation, CRC, encryption bit stream generation, and whitening
- Adaptive Frequency Hopping (AFH) using Packet Error Rate (PER)
- Interlaced scan for faster connection setup
- Simultaneous active ACL connection support
- Automatic ACL packet type selection
- Full master and slave piconet support
- Scatternet support
- Standard SDIO and UART HCI transport layer
- HCI layer to integrate with profile stack
- SCO/eSCO links with hardware accelerated audio signal processing and hardware supported PPEC algorithm for speech quality improvement
- All standard SCO/eSCO voice coding
- All standard pairing, authentication, link key, and encryption operations
- Standard Bluetooth power saving mechanisms (i.e., hold, sniff modes, and sniff-subrating)
- Enhanced Power Control (EPC)
- Channel Quality Driven Data Rate (CQDDR)
- Wideband Speech (WBS) support (1 WBS link)
- Encryption (AES) support
- LTE/MWS coexistence

4.2 Bluetooth Low Energy (LE)

- Broadcaster, observer, central, and peripheral roles
- Supports link layer topology to be master and slave (connects up to 16 links)
- Wi-Fi/Bluetooth Coexistence Arbiter (BCA) capability
- Shared RF with Bluetooth BDR/EDR
- Encryption (AES) support
- Intelligent Adaptive Frequency Hopping (AFH)
- Bluetooth LE Privacy 1.2
- Bluetooth LE Secure Connection
- Bluetooth LE Data Length Extension
- Bluetooth LE Advertising Extension
- Direction Finding—Connection-oriented Angle of Arrival (AoA)

4.3 Bluetooth host interfaces

- SDIO 3.0
- High-speed UART

4.4 PCM interface

- Master or slave mode
- PCM bit width size of 8 bits or 16 bits
- Up to 4 slots with configurable bit width and start positions
- Short frame and long frame synchronization
- Tri-state PCM interface capability

5 Pin information

5.1 Signal diagram

Note: Signals may be muxed. See [Linktext-Section_number-page](#) (*BRF_ANT* signal is muxed with *RF_TR_2* pin; Bluetooth external coexistence signals are muxed with both *GPIO[11:8]* and *SD_DAT[3:0]* pins).

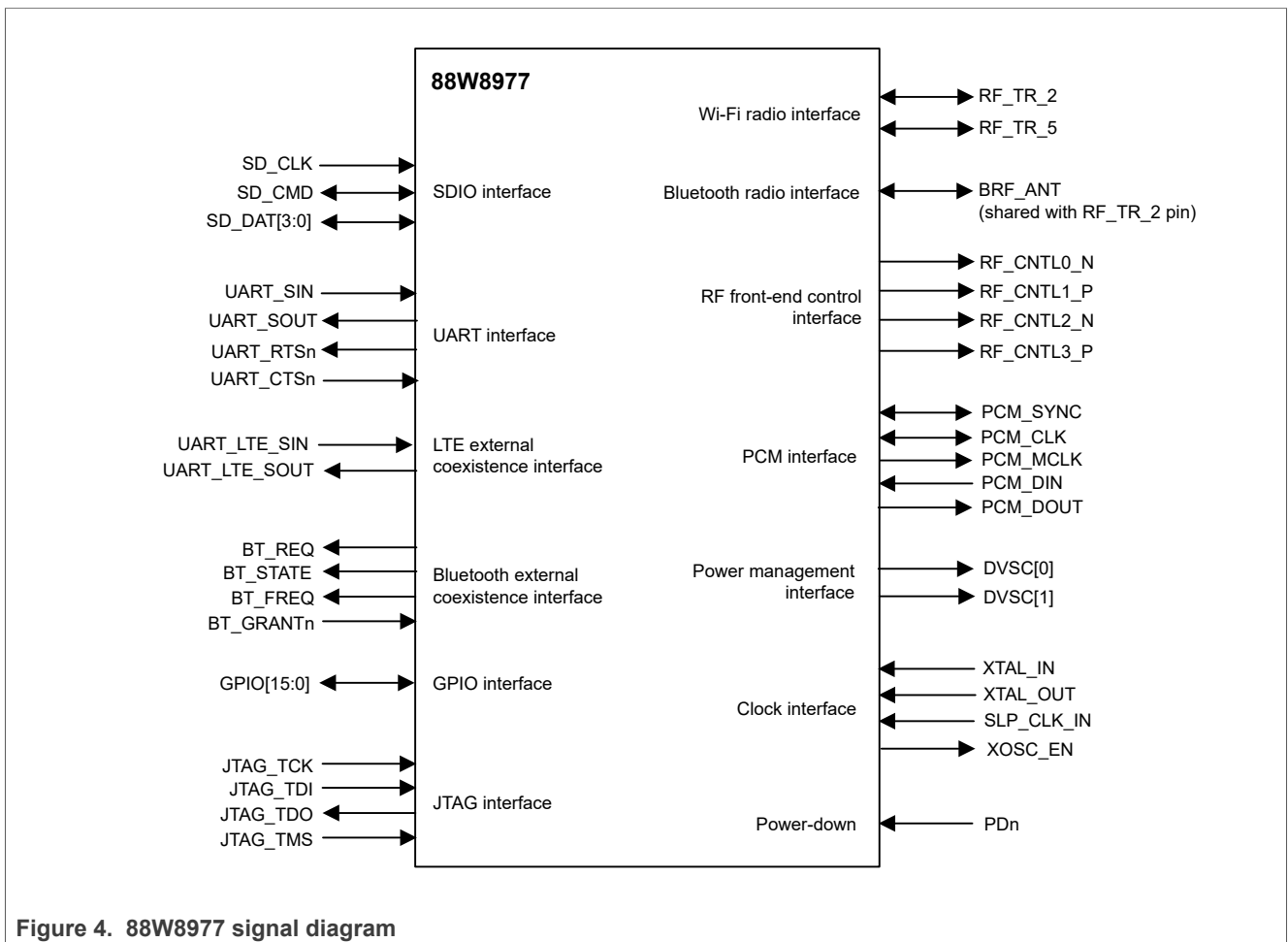
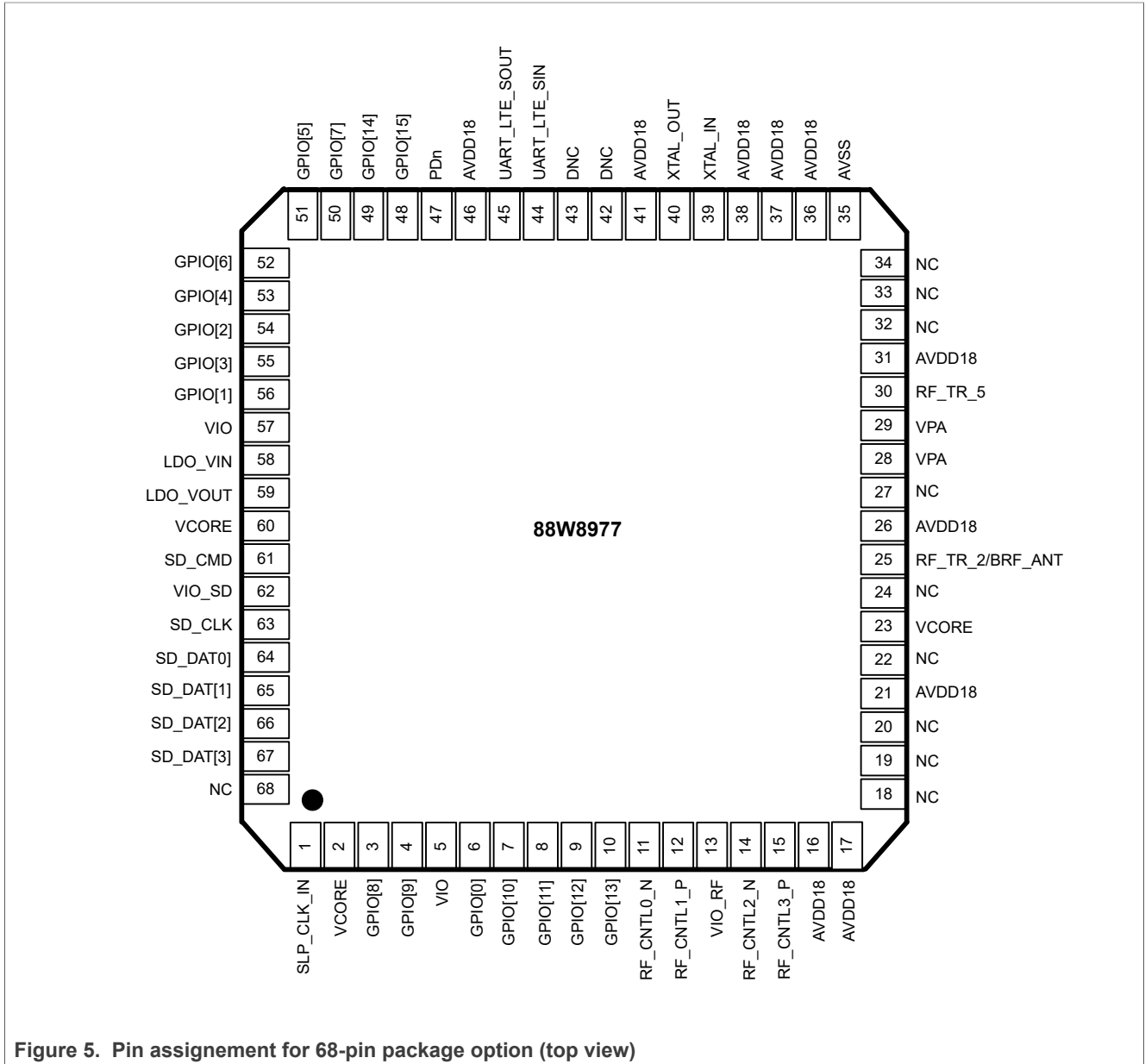

Figure 4. 88W8977 signal diagram

5.2 Pin assignment - 68-pin QFN package option

Note: Pins may have muxed signals. See Section 5.4 "Pin description".



5.3 Pad locations - 74-bump eWLP

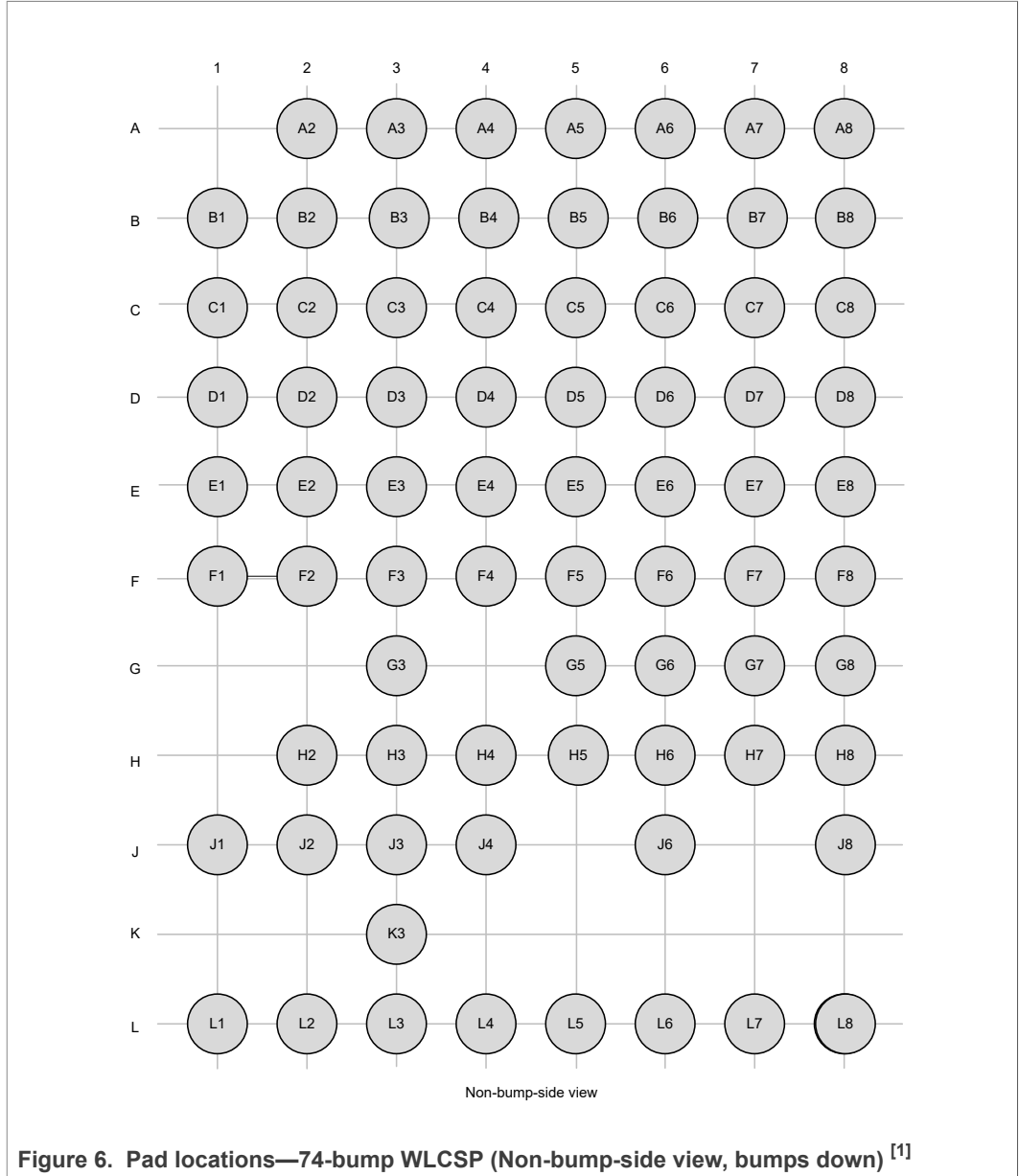

[1] Alphanumeric designations are approximations to the grid.

Table 2. Pad locations—74-bump eWLP^[1]

Pin Name	Alpha-Numeric Designation	Flip Chip Pad Location Relative to Die Center (non-bump-side view)	
		X	Y
VIO	A2	-1000.0	2000.0
VSS	A3	-600.0	2000.0
LDO_VIN	A4	-200.0	2000.0

Table 2. Pad locations—74-bump eWLP^[1]...continued

Pin Name	Alpha-Numeric Designation	Flip Chip Pad Location Relative to Die Center (non-bump-side view)	
		X	Y
VIO_SD	A5	200.0	2000.0
SD_DAT[0]	A6	600.0	2000.0
SD_DAT[1]	A7	1000.0	2000.0
VSS	A8	1400.00	2000.0
GPIO[5]	B1	-1400.0	1600.0
GPIO[6]	B2	-1000.0	1600.0
GPIO[3]	B3	-600.0	1600.0
LDO_VOUT	B4	-200.0	1600.0
VCORE	B5	200.0	1600.0
SD_CLK	B6	600.0	1600.0
SD_DAT[2]	B7	1000.0	1600.0
SD_DAT[3]	B8	1400.00	1600.0
AVDD18	C1	-1400.0	1200.0
GPIO[7]	C2	-1000.0	1200.0
GPIO[4]	C3	-600.0	1200.0
GPIO[2]	C4	-200.0	1200.0
GPIO[1]	C5	200.0	1200.0
SD_CMD	C6	600.0	1200.0
SLP_CLK_IN	C7	1000.0	1200.0
VSS	C8	1400.00	1200.0
AVDD18	D1	-1400.0	800.0
AVSS	D2	-1000.0	800.0
PDn	D3	-600.0	800.0
GPIO[14]	D4	-200.0	800.0
GPIO[15]	D5	200.0	800.0
GPIO[8]	D6	600.0	800.0
GPIO[0]	D7	1000.0	800.0
VIO	D8	1400.00	800.0
XTAL_IN	E1	-1400.0	400.0
XTAL_OUT	E2	-1000.0	400.0
DNC	E3	-600.0	400.0
DNC	E4	-200.0	400.0
UART_LTE_SOUT	E5	200.0	400.0
GPIO[9]	E6	600.0	400.0

Table 2. Pad locations—74-bump eWLP^[1]...continued

Pin Name	Alpha-Numeric Designation	Flip Chip Pad Location Relative to Die Center (non-bump-side view)	
		X	Y
GPIO[10]	E7	1000.0	400.0
GPIO[13]	E8	1400.00	400.0
AVDD18	F1	-1400.0	0.0
AVSS	F2	-1000.0	0.0
AVDD18	F3	-600.0	0.0
AVSS	F4	-200.0	0.0
UART_LTE_SIN	F5	200.0	0.0
GPIO[11]	F6	600.0	0.0
GPIO[12]	F7	1000.0	0.0
VIO_RF	F8	1400.00	0.0
AVSS	G3	-600.0	-400.0
RF_CNTL0_N	G5	200.0	-400.0
RF_CNTL1_P	G6	600.0	-400.0
RF_CNTL2_N	G7	1000.0	-400.0
RF_CNTL3_P	G8	1400.00	-400.0
AVDD18	H2	-1000.0	-800.0
AVSS	H3	-600.0	-800.0
VCORE	H4	-200.0	-800.0
AVSS	H5	200.0	-800.0
AVSS	H6	600.0	-800.0
AVSS	H7	1000.0	-800.0
AVDD18	H8	1400.0	-800.0
AVSS	J1	-1400.0	-1200.0
AVSS	J2	-1000.0	-1200.0
AVSS	J3	-600.0	-1200.0
AVSS	J4	-200.0	-1200.0
AVSS	J6	600.0	-1200.0
AVDD18	J8	1400.0	-1200.0
VPA	K3	-600.00	-1600.0
NC	L1	-1400.0	-2000.0
RF_TR_5	L2	-1000.0	-2000.0
DNC	L3	-600.0	-2000.0
RF_TR_2	L4	-200.0	-2000.0
AVDD18	L5	200.0	-2000.0

Table 2. Pad locations—74-bump eWLP^[1]...continued

Pin Name	Alpha-Numeric Designation	Flip Chip Pad Location Relative to Die Center (non-bump-side view)	
		X	Y
AVDD18	L6	600.0	-2000.0
AVSS	L7	1000.0	-2000.0
NC	L8	1400.0	-2000.0

[1] Alphanumeric designations are approximations to the grid shown in [Figure 6](#).

5.4 Pin description

5.4.1 Pin types

Table 3. Pin types

Pin type	Description
I/O	Digital input/output
I	Digital input
O	Digital output
A, I	Analog input
A,O	Analog output
NC	No connect
DNC	Do not connect
Power	Power
Ground	Ground

5.4.2 Pin states

The pin state information provided in this section is defined as follows:

- After firmware is downloaded, pads like GPIO and RF control are programmed in functional mode per the functionality of the pins
- The Hardware State (HW State) at power-on may differ based on the pin muxing/strap setting. The HW State is the pin state at power-on after boot code finishes and before firmware download begins (firmware may change the pin state). For example, for UART_RTSn and UART_SOUT, the boot code will enable the UART interface, making the HW states output high and output low, respectively.
- PD State denotes the power-down state in default configuration. Many pads have programmable power-down values, which can be set by firmware.
- PD Prog denotes whether the power-down state is programmable or not
- PU denotes whether the pull-up is programmable or not
- PD denotes whether the pull-down is programmable or not
- Pull-up and pull-down are only effective when the pad is in input mode.
- For SDIO, once the command is received from the host, the pads are configured accordingly

5.4.3 General Purpose I/O (GPIO)/LED interface

Table 4. General purpose I/O/LED interface

Pin Name	Supply	No Pad Power State	Reset State	HW State	PD State	PD Prog	Internal PU/PD	PU	PD
GPIO[15]	VIO	tristate	input	input	tristate	yes	nominal PU	yes	yes
GPIO Mode: GPIO[15] (input/output) JTAG Mode: JTAG_TMS, JTAG controller select (input)									
GPIO[14]	VIO	tristate	input	input	tristate	yes	nominal PU	yes	yes
GPIO Mode: GPIO[14] (input/output) JTAG Mode: JTAG_TCK, JTAG test clock (input)									
GPIO[13]	VIO	tristate	input	input	tristate	yes	nominal PU	yes	yes
GPIO Mode: GPIO[13] (input/output)									
GPIO[12]	VIO	tristate	input	input	tristate	yes	nominal PU	yes	yes
GPIO Mode: GPIO[12] (input/output)									
GPIO[11]	VIO	tristate	input	input	tristate	yes	weak PU	no	no
GPIO Mode: GPIO[11] (input/output) UART Mode: UART_RTSn (output) (active low) Bluetooth External Coexistence Mode: BT_REQ. See Section 5.4.6 "Bluetooth external coexistence interface" .									
GPIO[10]	VIO	tristate	input	input	tristate	yes	nominal PU	yes	yes
GPIO Mode: GPIO[10] (input/output) UART Mode: UART_CTSn (input) (active low) Bluetooth External Coexistence Mode: BT_GRANTn. See Section 5.4.6 "Bluetooth external coexistence interface" .									
GPIO[9]	VIO	tristate	input	input	tristate	yes	nominal PU	no	no
GPIO Mode: GPIO[9] (input/output) UART Mode: UART_SIN (input) Bluetooth External Coexistence Mode: BT_STATE. See Section 5.4.6 "Bluetooth external coexistence interface" .									
GPIO[8]	VIO	tristate	input	input	tristate	yes	weak PU	no	no
GPIO Mode: GPIO[8] (input/output) UART Mode: UART_SOUT (output) Bluetooth External Coexistence Mode: BT_FREQ. See Section 5.4.6 "Bluetooth external coexistence interface" .									
GPIO[7]	VIO	tristate	input	input	tristate	yes	nominal PU	no	no
GPIO Mode: GPIO[7] (input/output) PCM Mode: PCM_SYNC (input/output) <ul style="list-style-type: none"> • Output if master • Input if slave 									
GPIO[6]	VIO	tristate	input	input	tristate	yes	nominal PU	yes	yes
GPIO Mode: GPIO[6] (input/output) PCM Mode: PCM_CLK (input/output) <ul style="list-style-type: none"> • Output if master • Input if slave 									
GPIO[5]	VIO	tristate	input	input	tristate	yes	weak PU	yes	yes

Table 4. General purpose I/O/LED interface...continued

Pin Name	Supply	No Pad Power State	Reset State	HW State	PD State	PD Prog	Internal PU/PD	PU	PD
GPIO Mode: GPIO[5] (input/output) PCM Mode: PCM_DOUT (output)									
GPIO[4]	VIO	tristate	input	input	tristate	yes	nominal PU	no	no
GPIO Mode: GPIO[4] (input/output) PCM Mode: PCM_DIN (input)									
GPIO[3]	VIO	tristate	input	input	tristate	yes	weak PU	yes	yes
GPIO Mode: GPIO[3] (input/output) Power Management Mode: DVSC[1] Digital voltage scaling control (output) JTAG Mode: JTAG_TDO, JTAG test data (output)									
GPIO[2]	VIO	tristate	input	input	tristate	yes	weak PU	yes	yes
GPIO Mode: GPIO[2] (input/output) Power Management Mode: DVSC[0] Digital voltage scaling control (output) JTAG Mode: JTAG_TDI, JTAG test data (input)									
GPIO[1]	VIO	tristate	input	input	tristate	yes	weak PU	no	no
GPIO Mode: GPIO[1] (input/output)									
GPIO[0]	VIO	tristate	output	output	drive low	yes	weak PU	yes	no
GPIO Mode: GPIO[0] (input/output) Oscillator Mode: XOSC_EN/CLK_REQ (output) (active high) 0 = disable external oscillator 1 = enable external oscillator									

5.4.4 RF front-end control interface

Table 5. RF front-end control interface

Pin Name	Supply	No Pad Power State	Reset State	HW State	PD State	PD Prog	Internal PU/PD	PU	PD
RF_CNTL0_N	VIO_RF	tristate	input	output	drive low	yes	weak PU	no	no
RF Control 0—RF Control Output Low (output) This pin is used as a configuration pin: CON[0] (input) See Section 5.5 "Configuration pins" .									
RF_CNTL1_P	VIO_RF	tristate	input	output	drive high	yes	weak PU	no	no
RF Control 1—RF Control Output High (output)									
RF_CNTL2_N	VIO_RF	tristate	input	output	drive low	yes	weak PU	no	no
RF Control 2—RF Control Output Low (output) This pin is used as a configuration pin: CON[1] (input) See Section 5.5 "Configuration pins" .									
RF_CNTL3_P	VIO_RF	tristate	input	output	drive high	yes	weak PU	no	no
RF Control 3—RF Control Output High (output)									

5.4.5 Wi-Fi/Bluetooth radio interface

Table 6. Wi-Fi/Bluetooth radio interface

Pin Name	Type	Supply	Description
RF_TR_2 / BRF_ANT	A, I/O	AVDD18	Wi-Fi: Wi-Fi Transmit/Receive (2.4 GHz) Bluetooth: Bluetooth Transmit/Receive
RF_TR_5	A, I/O	AVDD18	Wi-Fi Transmit/Receive (5 GHz)

5.4.6 Bluetooth external coexistence interface

Table 7. Bluetooth external coexistence interface

Pin Name	Supply	No Pad Power State	Reset State	HW State	PD State	PD Prog	Internal PU/PD	PU	PD
BT_GRANTn	VIO	tristate	input	input	tristate	yes	nominal PU	yes	yes
Coexistence Mode: BT_GRANTn input (active low) SDIO Mode: SD_DAT[0]. See Section 5.4.7 "SDIO host interface" . GPIO Mode: GPIO[10]. See Section 5.4.3 "General Purpose I/O (GPIO)/LED interface" .									
BT_STATE	VIO	tristate	output	output	tristate	yes	nominal PU	yes	yes
Coexistence Mode: BT_STATE output SDIO Mode: SD_DAT[2]. See Section 5.4.7 "SDIO host interface" . GPIO Mode: GPIO[9]. See Section 5.4.3 "General Purpose I/O (GPIO)/LED interface" .									
BT_REQ	VIO	tristate	output	output	tristate	yes	nominal PU	yes	yes
Coexistence Mode: BT_REQ output SDIO Mode: SD_DAT[3]. See Section 5.4.7 "SDIO host interface" . GPIO Mode: GPIO[11]. See Section 5.4.3 "General Purpose I/O (GPIO)/LED interface" .									
BT_FREQ	VIO	tristate	output	output	tristate	yes	nominal PU	yes	yes
Coexistence Mode: BT_FREQ output SDIO Mode: SD_DAT[1]. See Section 5.4.7 "SDIO host interface" . GPIO Mode: GPIO[8]. See Section 5.4.3 "General Purpose I/O (GPIO)/LED interface" .									
NOTE: Bluetooth external coexistence pin functions are unavailable when the SDIO interface signals are used.									

5.4.7 SDIO host interface

Table 8. SDIO host interface

Pin Name	Supply	No Pad Power State	Reset State	HW State	PD State	PD Prog	Internal PU/PD	PU	PD
SD_CLK	VIO_SD	tristate	input	input	tristate	no	nominal PU	yes	yes
SDIO 4-bit Mode: Clock input SDIO 1-bit Mode: Clock input									
SD_CMD	VIO_SD	tristate	input	input	tristate	no	nominal PU	yes	yes
SDIO 4-bit Mode: Command/response (input/output) SDIO 1-bit Mode: Command line									
SD_DAT[3]	VIO_SD	tristate	input	input	tristate	no	nominal PU	yes	yes
SDIO 4-bit Mode: Data line Bit[3] SDIO 1-bit Mode: Reserved Bluetooth External Coexistence Mode: BT_REQ. See Section 5.4.6 "Bluetooth external coexistence interface" .									
SD_DAT[2]	VIO_SD	tristate	input	input	tristate	no	nominal PU	yes	yes
SDIO 4-bit Mode: Data line Bit[2] or read wait (optional) SDIO 1-bit Mode: Read wait (optional) Bluetooth External Coexistence Mode: BT_STATE. See Section 5.4.6 "Bluetooth external coexistence interface" .									
SD_DAT[1]	VIO_SD	tristate	input	input	tristate	no	nominal PU	yes	yes
SDIO 4-bit Mode: Data line Bit[1] SDIO 1-bit Mode: Interrupt Bluetooth External Coexistence Mode: BT_FREQ. See Section 5.4.6 "Bluetooth external coexistence interface" .									
SD_DAT[0]	VIO_SD	tristate	input	input	tristate	no	nominal PU	yes	yes
SDIO 4-bit Mode: Data line Bit[0] SDIO 1-bit Mode: Data line Bluetooth External Coexistence Mode: BT_GRANT. See Section 5.4.6 "Bluetooth external coexistence interface" .									
NOTE: SDIO pin functions are unavailable when the Bluetooth external coexistence interface signals are used.									

5.4.8 UART host interface

Table 9. UART host interface (MFP)

NOTE: Pins may be Multi-Functional Pins (MFP). See pin descriptions for functional modes.

Pin Name	Type	Supply	Description
UART_SIN	I	VIO	UART serial input signal - GPIO[9] input/output
UART_SOUT	O	VIO	UART serial output signal - GPIO[8] input/output
UART_RTSn	O	VIO	UART request-to-send output signal . Active low - GPIO[11] input/output
UART_CTSn	I	VIO	UART clear-to-send input signal - Active low - GPIO[10] input/output

5.4.9 LTE external coexistence interface

Table 10. LTE interface

Pin Name	Supply	No Pad Power State	Reset State	HW State	PD State	PD Prog	Internal PU	PU	PD
UART_LTE_SIN	VIO	tristate	input	input	tristate	yes	weak PU	yes	yes
UART_LTE_SIN (input)									
UART_LTE_SOUT	VIO	tristate	input	input	tristate	yes	weak PU	yes	yes
UART_LTE_SOUT (output)									

5.4.10 PCM interface

Table 11. PCM interface pins (MFP)

NOTE: Pins may be Multi-Functional Pins (MFP). See pin descriptions for functional modes.

Pin Name	Type	Supply	Description
PCM_DIN	I	VIO	Receive PCM input. GPIO[4] input/output
PCM_DOUT	O	VIO	Transmit PCM output. GPIO[5] input/output
PCM_SYNC	I/O	VIO	PCM frame sync. GPIO[7] input/output <ul style="list-style-type: none"> Output if master Input if slave
PCM_CLK	I/O	VIO	PCM data clock. GPIO[6] input/output <ul style="list-style-type: none"> Output if master Input if slave

5.4.11 Power management interface

Table 12. Power management interface pins (MFP)

NOTE: Pins may be Multi-Functional Pins (MFP). See pin descriptions for functional modes.

Pin Name	Type	Supply	Description
DVSC[1]	O	VIO	Digital voltage scaling control output signal. GPIO[3] input/output
DVSC[0]	O	VIO	Digital voltage scaling control output signal. GPIO[2] input/output

5.4.12 Power supply and ground pins

Table 13. Power supply and ground pins

Pin Name	Type	Description
VCORE	Power	1.05V Core Power Supply
VIO	Power	1.8V/2.5V/3.3V Digital I/O Power Supply
VIO_SD	Power	1.8V/3.3V Digital I/O SDIO Power Supply
VIO_RF	Power	1.8V/3.3V Analog I/O RF Power Supply
AVDD18	Power	1.8V Analog Power Supply
VPA	Power	2.2V Analog Power Supply
LDO_VIN	Power	LDO Voltage Input (1.8V)
LDO_VOUT	Power	LDO Voltage Output
AVSS	Ground	Ground
VSS	Ground	Ground
NC	NC	No Connected
DNC	DNC	Do Not Connect Do not connect these pins. Leave these pins floating.

5.4.13 Clock interface

Table 14. Clock interface

Pin Name	Supply	No Pad Power State	Reset State	HW State	PD	PD Prog	Internal PU/PD	PU	PD
XTAL_IN	AVDD18	--	--	--	--	--	--	--	--
Crystal / Crystal Oscillator / System Clock Input Accepts 26 MHz reference clock signal. See Section 9.10 "Clock specifications" .									
XTAL_OUT	AVDD18	--	--	--	--	--	--	--	--
Crystal / Crystal Oscillator Output Connect this pin to ground when an external oscillator is used.									
SLP_CLK_IN	VIO	tristate	input	input	tristate	no	nominal PU	yes	yes
Sleep Clock Input (optional) Used for Wi-Fi and Bluetooth low-power modes. <ul style="list-style-type: none"> An external sleep clock is recommended for minimal current consumption. If no sleep clock input is provided, an internal sleep clock (derived from reference clock) will be used. This will cause an approximate ~50 uA current increase on the 3.3V rail, since the reference clock cannot be shut down during device sleep. If SLP_CLK_IN is not connected, the internal circuit will detect no signal, and firmware will initialize the sleep clock based on the reference clock. To reduce further leakage, do not ground the SLP_CLK_IN pin / keep it floating (DNC) for cases where a sleep clock derived from the reference clock will be used. 									
XOSC_EN	VIO	--	--	--	--	--	--	--	--
XOSC_EN/CLK_REQ (output) NOTE: Muxed with GPIO[0].									

5.4.14 Power-down pin

Table 15. Power-down pin

Pin Name	Supply	No Pad Power State	Reset State	HW State	PD State	PD Prog	Internal PU/PD	PU	PD
PDn	AVDD18	--	--	--	--	--	--	--	--

Full Power-Down (input) (active low)
 0 = full power-down mode
 1 = normal mode

- PDn can accept an input of 1.8V to 4.5V
- PDn may be driven by the host
- PDn must be high for normal operation

No internal pull-up on this pin.

5.4.15 JTAG interface

Table 16. JTAG interface pins (MFP)

NOTE: Pins may be Multi-Functional Pins (MFP). See pin descriptions for functional modes.

Pin Name	Type	Supply	Description
JTAG_TDO	O	VIO	JTAG test data output signal. GPIO[3] input/output
JTAG_TDI	I	VIO	JTAG test data input signal. GPIO[2] input/output
JTAG_TMS	I	VIO	JTAG test mode select input signal. GPIO[15] input/output
JTAG_TCK	I	VIO	JTAG test clock input signal. GPIO[14] input/output

5.5 Configuration pins

[Table 17](#) shows the pins used as configuration inputs to set the parameters following a reset. The definition of these pins changes immediately after reset to their usual function. To set a configuration bit to 0, attach a 100 kΩ resistor from the pin to ground. No external circuitry is required to set a configuration bit to 1.

Table 17. Configuration pins

Configuration Bits	Pin Name	Configuration Function
CON[1]	RF_CNTL2_N	Firmware Boot Options
CON[0]	RF_CNTL0_N	No hardware impact. Software reads and boots accordingly. See Table 18 Note: Boot code needs to use this host boot strap status to decide the correct boot sequence.

Table 18. Firmware boot options

Strap value	Wi-Fi	Bluetooth/ Bluetooth LE	Firmware download	Firmware download mode	Number of SDIO functions
00	--	--	--	--	--
01	--	--	--	--	--
10	SDIO	UART	SDIO + UART	Parallel/Serial	1 (Wi-Fi)
11	SDIO	SDIO	SDIO + SDIO	Parallel/Serial	2 (Wi-Fi, Bluetooth)

6 Power information

The table in [Section 5.4.12 "Power supply and ground pins"](#) shows the required voltage levels for each rail and PDn input signal.

6.1 Leakage optimization

For applications not using Wi-Fi and Bluetooth, the device can be put into a low-leakage mode of operation. Methods include:

- Using the power-down (PDn) pin
The power-down state provides the lowest leakage mode of operation. Assert PDn low to enter power-down. If the firmware is not downloaded, the device must be kept in power-down mode to reduce leakage.
- All rails powered off

Alternatively, all power rails can be powered off. In this case, the state of PDn pin is irrelevant.

6.2 Power-up

The 88W8977 VCORE is supplied through either an external PMIC or the internal LDO. In both cases, the PDn pin of the 88W8977 is tied to 1.8V.

The power configurations include:

- [Section 6.2.1 "Configuration—PMIC supplies VCORE"](#)
- [Section 6.2.2 "Configuration—Internal LDO supplies VCORE"](#)

In either configuration, the ramp-up is controlled by the Host using the PMIC_EN pin.

- PMIC_EN represents the input enable pin (EN) of the power regulator.
- PMIC_EN ramps up from Host 3.3V
- PMIC_EN ramps up from Host GPIO pin

[Section 6.2.3 "Power-up sequence"](#) shows the power-up sequence for both configurations.

6.2.1 Configuration—PMIC supplies V_{CORE}

- PMIC supplies V_{CORE}
- PMIC_EN ramps up from the host 3.3V or the host GPIO pin
- AVDD18 supplies PDn (follow AVDD18; PDn is connected to 1.8V supply)
- PMIC supplies the external VPA and AVDD18 power supply pins
- The host (1.8V/3.3V) supplies the external VIO/VIO_REF power supply pins

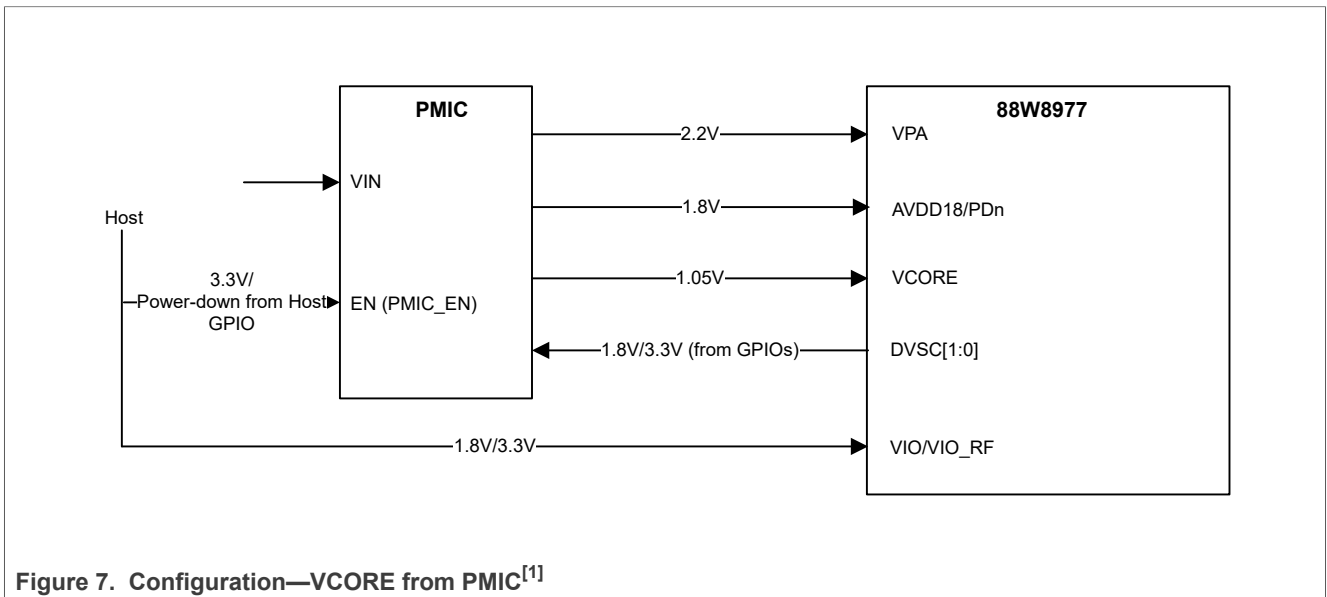

Figure 7. Configuration—V_{CORE} from PMIC^[1]

[1] A minimum time of 100 ms is required after PMIC_EN is deasserted (=0) and before it is asserted (=1).

6.2.2 Configuration—Internal LDO supplies V_{CORE}

- LDO_VOUT supplies V_{CORE}
- PMIC_EN ramps up from Host 3.3V or Host GPIO pin
- AVDD18 supplies PDn (follow AVDD18; PDn connected to 1.8V supply)
- PMIC supplies the external VPA and AVDD18/LDO_VIN power supply pins
- The host (1.8V/3.3V) supplies the external VIO/VIO_REF power supply pins

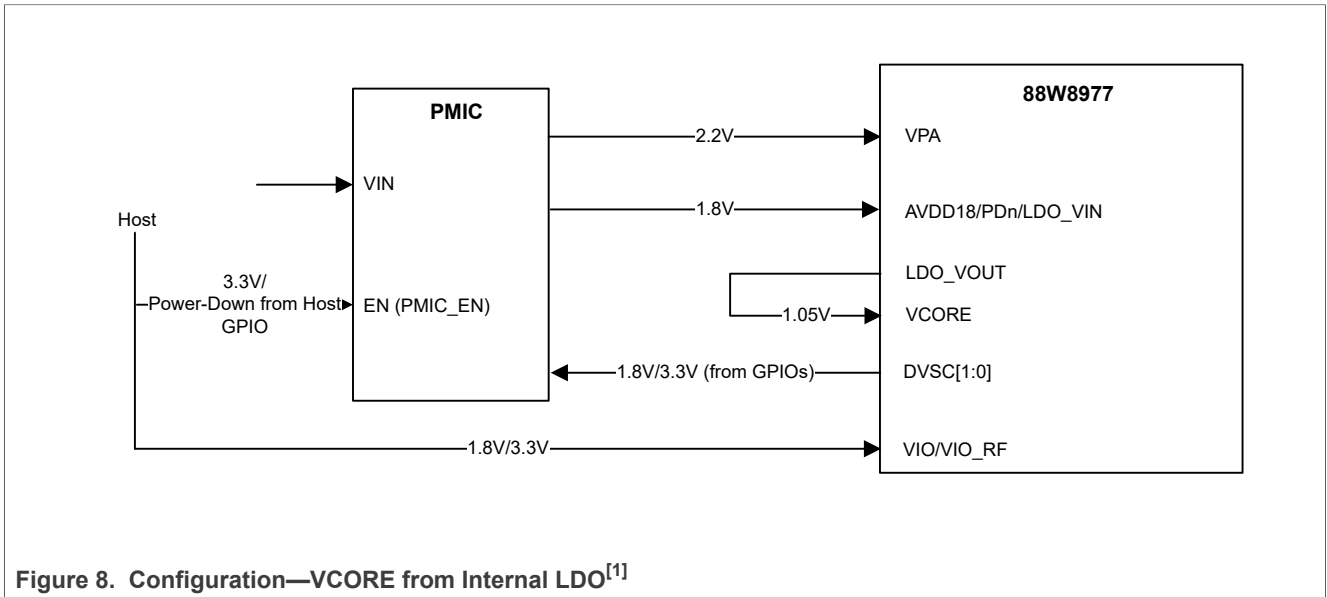

Figure 8. Configuration—V_{CORE} from Internal LDO^[1]

[1] A minimum time of 100 ms is required after PMIC_EN is deasserted (=0) and before it is asserted (=1).

6.2.3 Power-up sequence

- VPA must be good (90%) before AVDD18 starts ramping up.
- AVDD18 must be good (90%) before VCORE starts ramping up.

Figure 9 shows the power-up sequence.

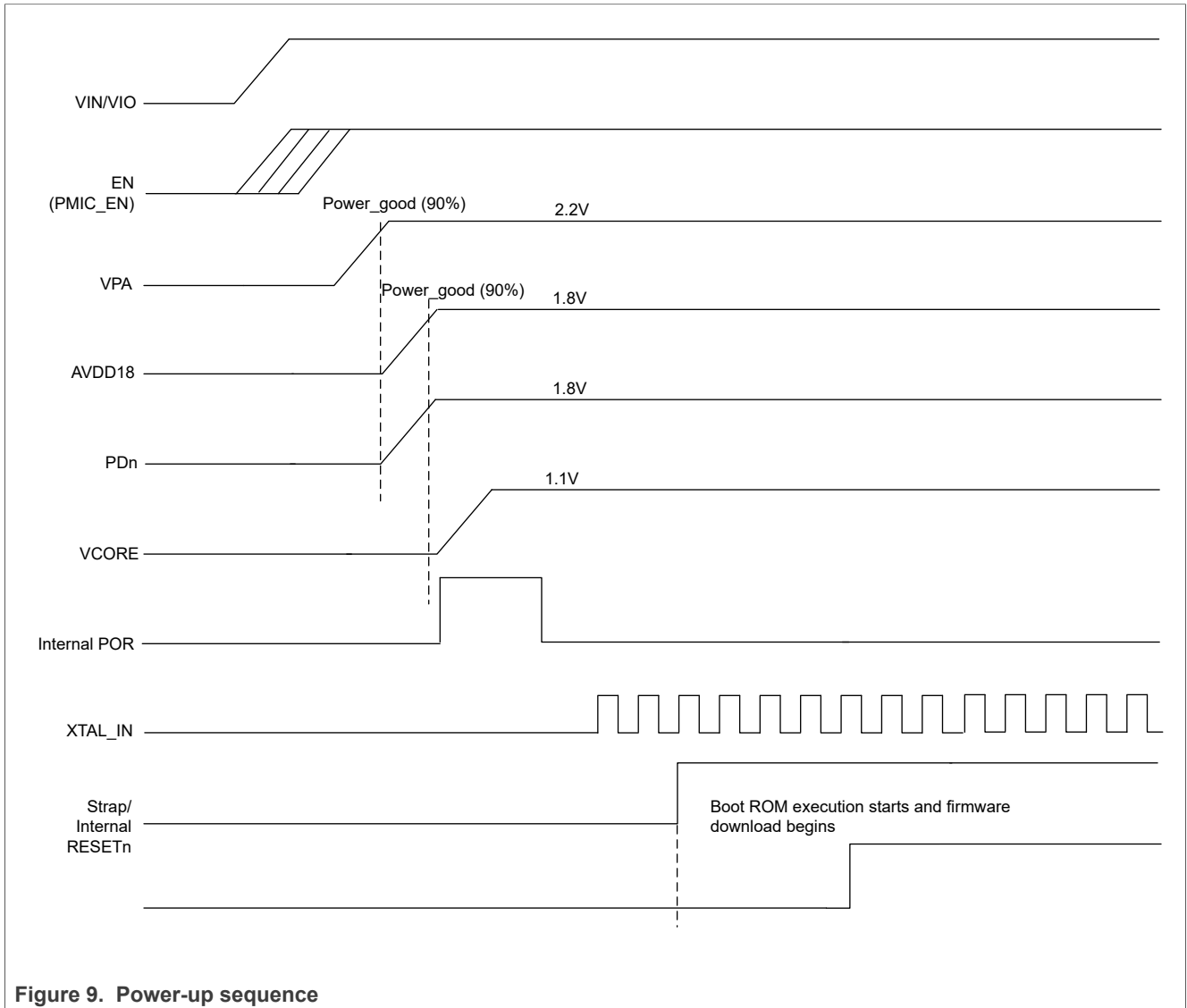

6.3 Power-down

6.3.1 Recommended power-down sequence

In the recommended power-down sequence, VPA ramps down before AVDD18 in order for the RF PA to turn the logic off (depends on the control logic generated from AVDD18). Also, when the PMIC VBAT is removed, the PMIC cannot guarantee a ramp-down requirement.

[Figure 10](#) shows the recommended (but not required) power-down sequence.

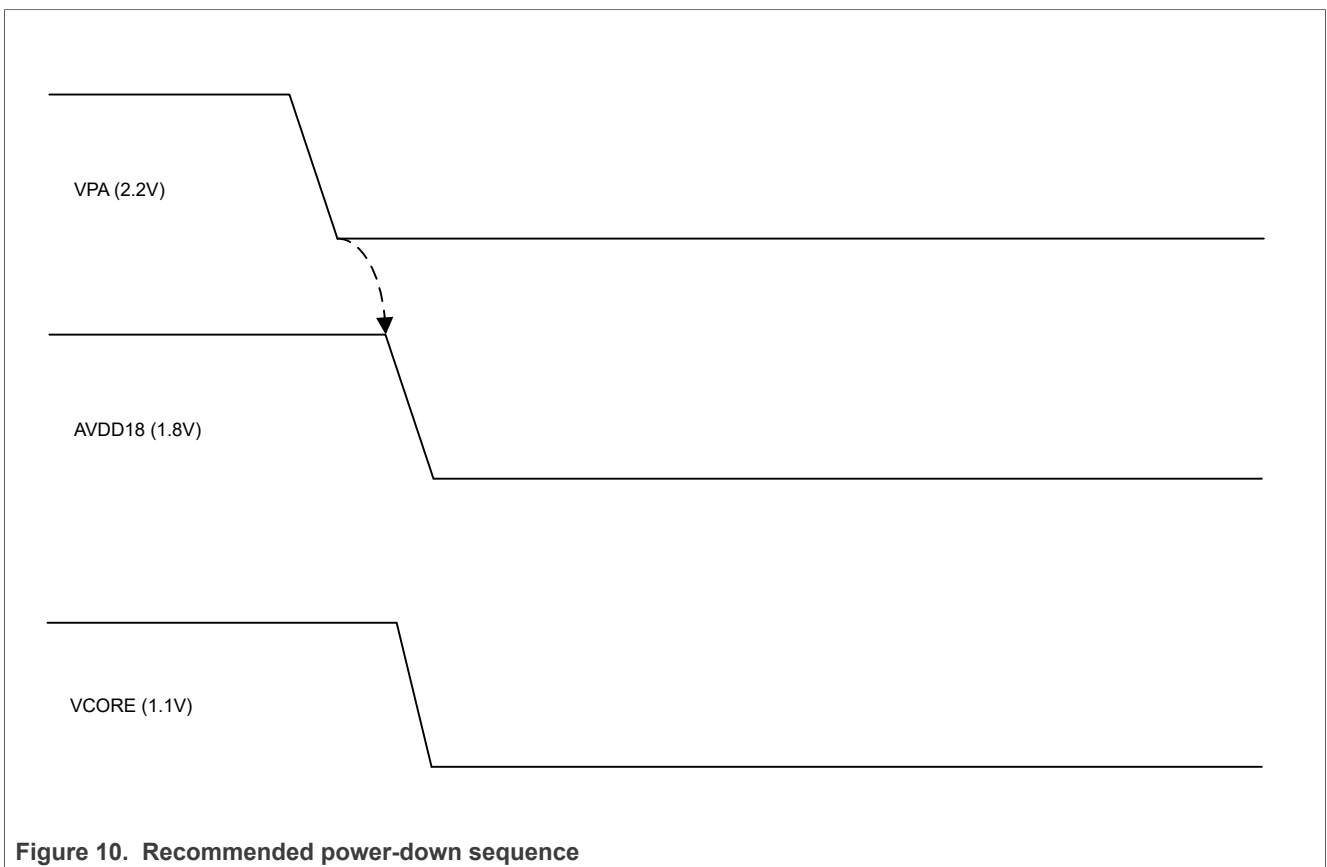

Figure 10. Recommended power-down sequence

6.3.2 Power-down using PMIC_EN host pin

The maximum ramp-down time for V_{CORE} from PMIC_EN assertion is 10 ms. PMIC_EN must be asserted a minimum of 100 ms to guarantee that V_{CORE} and AVDD18 are discharged to less than 0.2V for the POR to generate properly after PMIC_EN is deasserted.

Figure 11 shows the sequence.

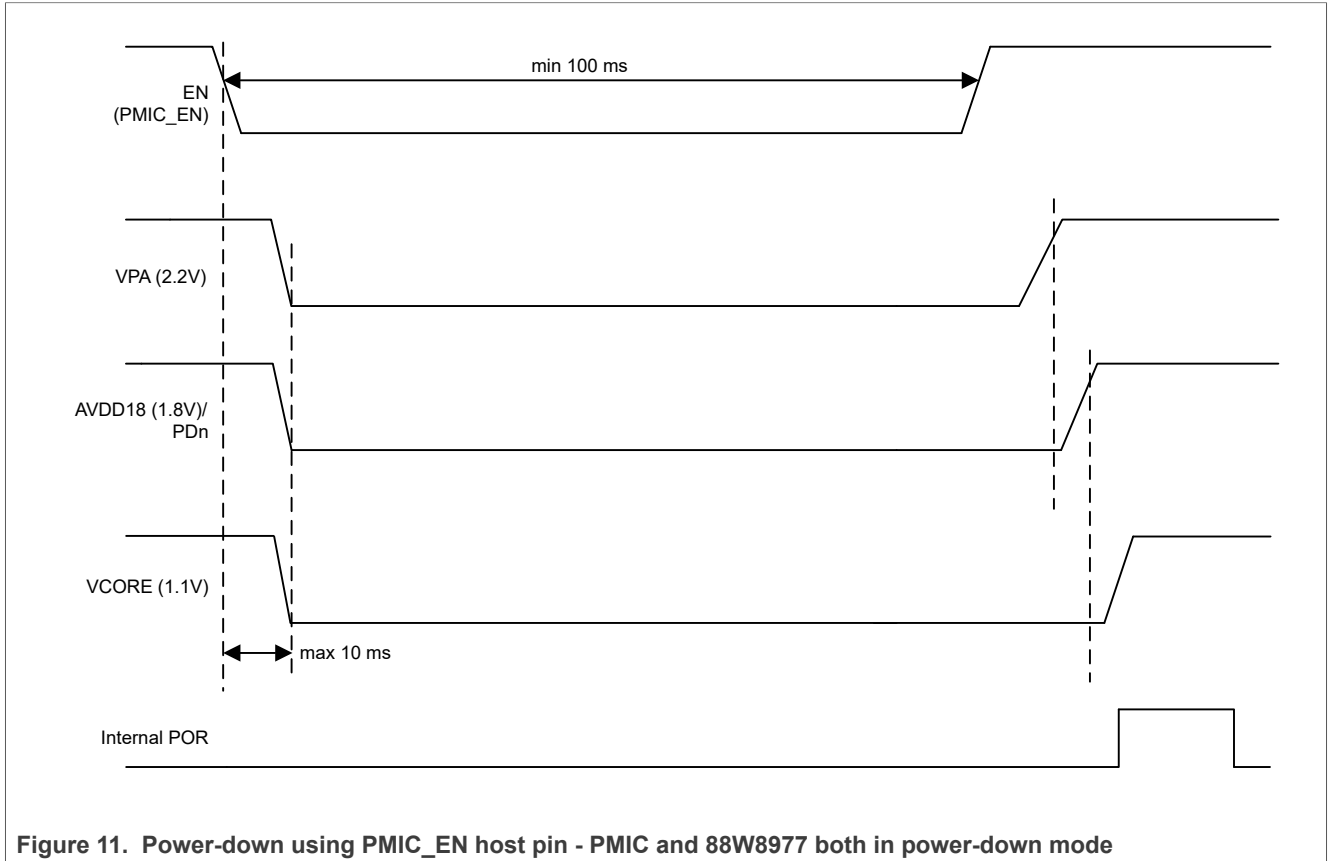

Figure 11. Power-down using PMIC_EN host pin - PMIC and 88W8977 both in power-down mode

6.4 Deep sleep

When a programmable power regulator is used to supply V_{CORE}, 88W8977 may use the power management interface to reduce V_{CORE} to approximately 0.8V to reduce the power consumption in deep sleep mode.

7 Absolute maximum ratings

Note: The absolute maximum ratings table defines the limitations for electrical and thermal stresses. These limits prevent permanent damage to the device. Exposure to conditions at or beyond these ratings is not guaranteed and can damage the device.

Table 19. Absolute Maximum Ratings

Symbol	Parameter	Conditions	Min	Typ	Max	Unit
V _{CORE}	Power supply voltage with respect to V _{SS}	--	--	1.05	1.21	V
V _{IO}	Power supply voltage with respect to V _{SS}	--	--	1.8	2.2	V
		--	--	2.5	3.0	V
		--	--	3.3	4.0	V
V _{IO_SD}	Power supply voltage with respect to V _{SS}	--	--	1.8	2.2	V
		--	--	3.3	4.0	V
V _{IO_RF}	Power supply voltage with respect to V _{SS}	--	--	1.8	2.2	V
		--	--	3.3	4.0	V
AVDD18	Power supply voltage with respect to V _{SS}	--	--	1.8	1.98	V
V _{PA}	Power supply voltage with respect to V _{SS}	--	--	2.2	2.3	V
LDO_V _{IN}	Power supply voltage with respect to V _{SS}	--	--	1.8	2.0	V
T _{STORAGE}	Storage temperature	--	-55	--	+125	°C
V _{ESD}	Electrostatic discharge voltage	human body model (HBM) ^[1]	-1	--	+1	kV
		charged device model (CDM) ^[2]	-500	--	+500	V

[1] According to JESD22-A114F

[2] According to JESD22-C101E

8 Recommended operating conditions

Note: Operation beyond the recommended operating conditions is neither recommended nor guaranteed.

Table 20. Recommended Operating Conditions

Symbol	Parameter	Condition	Min	Typ	Max	Unit
V _{CORE}	1.05V core power supply	--	1.00	1.05	1.15	V
V _{IO}	1.8V/2.5V/3.3V digital I/O power supply	--	1.62	1.8	1.98	V
		--	2.25	2.5	2.75	V
		--	2.97	3.3	3.47	V
V _{IO_SD}	1.8V/3.3V digital I/O SDIO power supply	--	1.62	1.8	1.98	V
		--	2.97	3.3	3.47	V
V _{IO_RF}	1.8V/3.3V I/O power supply	--	1.62	1.8	1.98	V
		--	2.97	3.3	3.47	V
AVDD18	1.8V analog power supply	--	1.71	1.8	1.89	V
VPA	2.2V analog power supply	--	2.09	2.2	2.26	V
LDO_VIN	LDO input voltage supply	--	1.71	1.8	1.89	V
T _A	Ambient operating temperature	Extended	-30	--	85	°C
		Industrial	-40	--	85	°C
T _J	Maximum junction temperature	--	--	--	125	°C

9 Electrical specifications

9.1 GPIO/LED interface specifications

The GPIO pins are powered by the VIO voltage supply.

9.1.1 VIO DC characteristics

9.1.1.1 1.8V operation

Table 21. DC electricals—1.8V operation (VIO)

Symbol	Parameter	Condition	Min	Typ	Max	Unit
V _{IH}	Input high voltage	--	0.7*VIO	--	VIO+0.4	V
V _{IL}	Input low voltage	--	-0.4	--	0.3*VIO	V
V _{HYS}	Input hysteresis	--	100	--	--	mV
V _{OH}	Output high voltage	--	VIO-0.4	--	--	V
V _{OL}	Output low voltage	--	--	--	0.4	V

9.1.1.2 2.5V operation

Table 22. DC electricals—2.5V operation (VIO)

Symbol	Parameter	Condition	Min	Typ	Max	Unit
V _{IH}	Input high voltage	--	0.7*VIO	--	VIO+0.4	V
V _{IL}	Input low voltage	--	-0.4	--	0.3*VIO	V
V _{HYS}	Input hysteresis	--	100	--	--	mV
V _{OH}	Output high voltage	--	VIO-0.4	--	--	V
V _{OL}	Output low voltage	--	--	--	0.4	V

9.1.1.3 3.3V operation

Table 23. DC electricals—3.3V operation (VIO)

Symbol	Parameter	Condition	Min	Typ	Max	Unit
V _{IH}	Input high voltage	--	0.7*VIO	--	VIO+0.4	V
V _{IL}	Input low voltage	--	-0.4	--	0.3*VIO	V
V _{HYS}	Input hysteresis	--	100	--	--	mV
V _{OH}	Output high voltage	--	VIO-0.4	--	--	V
V _{OL}	Output low voltage	--	--	--	0.4	V

9.1.2 LED mode

Table 24. LED mode data

Over the full range of values specified in the Recommended Operating Conditions unless otherwise specified.

Symbol	Parameter	Condition	Typ	Unit
I_{OH}	Switching current high	Tristate on pad (requires pull-up on board)	Tristate when driving high	mA
I_{OL}	Switching current low	at 0.4V	10	mA

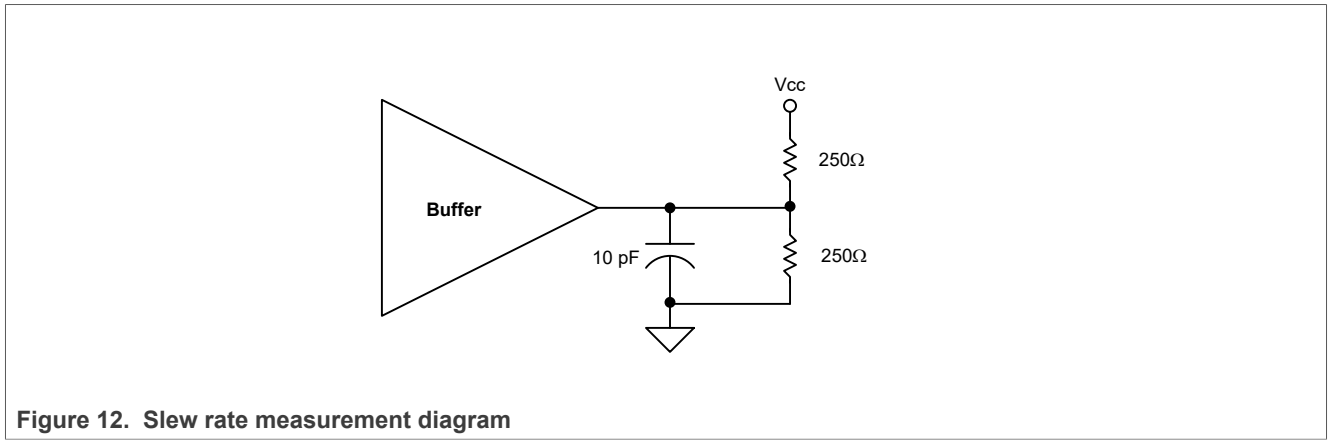

Figure 12. Slew rate measurement diagram

9.2 RF front-end control interface specifications

The RF front-end control pins are supplied by VIO_RF.

9.2.1 VIO_RF DC characteristics

9.2.1.1 1.8V operation

Table 25. DC electricals—1.8V operation (VIO_RF)

Symbol	Parameter	Condition	Min	Typ	Max	Unit
V _{IH}	Input high voltage	--	0.7*VIO_RF	--	VIO_RF+0.4	V
V _{IL}	Input low voltage	--	-0.4	--	0.3*VIO_RF	V
V _{HYS}	Input hysteresis	--	100	--	--	mV
V _{OH}	Output high voltage	--	VIO_RF-0.4	--	--	V
V _{OL}	Output low voltage	--	--	--	0.4	V

9.2.1.2 3.3V operation

Table 26. DC electricals—3.3V operation (VIO_RF)

Symbol	Parameter	Condition	Min	Typ	Max	Unit
V _{IH}	Input high voltage	--	0.7*VIO_RF	--	VIO_RF+0.4	V
V _{IL}	Input low voltage	--	-0.4	--	0.3*VIO_RF	V
V _{HYS}	Input hysteresis	--	100	--	--	mV
V _{OH}	Output high voltage	--	VIO_RF-0.4	--	--	V
V _{OL}	Output low voltage	--	--	--	0.4	V

9.3 Wi-Fi radio specifications

9.3.1 Wi-Fi radio performance measurement

The Wi-Fi transmit/receive performance is measured either at the antenna port or at the chip output port.

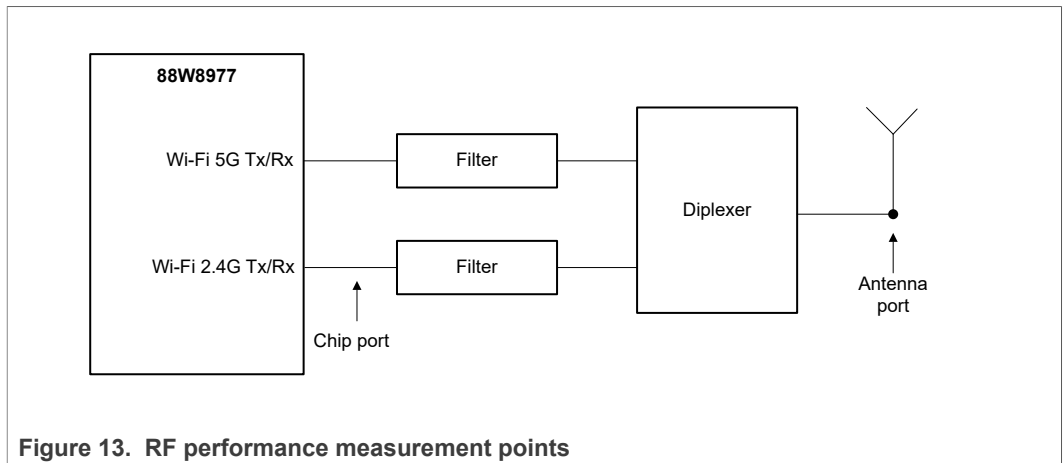

Figure 13. RF performance measurement points

9.3.2 2.4 GHz Wi-Fi receiver performance

Note: Unless otherwise stated, all specifications are at 25°C, nominal voltage, and at the chip port.

Table 27. 2.4 GHz Wi-Fi receiver performance

Parameter	Conditions	Min	Typ	Max	Unit
RF frequency range	2.4 GHz—IEEE 802.11n/g/b	2400	--	2500	MHz
Receiver input IP3 at RF high gain (in-band)	Receiver input IP3 when LNA in high gain mode (24 dB) at chip input	--	-20	--	dBm
Receiver sensitivity 802.11b	1 Mbit/s	--	-100	--	dBm
	2 Mbit/s	--	-96	--	dBm
	5.5 Mbit/s	--	-95	--	dBm
	11 Mbit/s	--	-91	--	dBm
Receiver sensitivity 802.11g	6 Mbit/s	--	-92	--	dBm
	9 Mbit/s	--	-92	--	dBm
	12 Mbit/s	--	-91	--	dBm
	18 Mbit/s	--	-89	--	dBm
	24 Mbit/s	--	-86	--	dBm
	36 Mbit/s	--	-83	--	dBm
	48 Mbit/s	--	-79	--	dBm
	54 Mbit/s	--	-77	--	dBm
Receiver sensitivity 802.11n, HT20 (with BCC)	MCS0	--	-92	--	dBm
	MCS1	--	-90	--	dBm
	MCS2	--	-88	--	dBm
	MCS3	--	-85	--	dBm
	MCS4	--	-82	--	dBm
	MCS5	--	-77	--	dBm
	MCS6	--	-76	--	dBm
	MCS7	--	-74	--	dBm
Receiver sensitivity 802.11n, HT40 (with BCC)	MCS0	--	-89	--	dBm
	MCS1	--	-88	--	dBm
	MCS2	--	-85	--	dBm
	MCS3	--	-83	--	dBm
	MCS4	--	-79	--	dBm
	MCS5	--	-75	--	dBm
	MCS6	--	-73	--	dBm
	MCS7	--	-72	--	dBm

Table 27. 2.4 GHz Wi-Fi receiver performance...continued

Parameter	Conditions	Min	Typ	Max	Unit
Receiver maximum input level 802.11	802.11b	--	-1	--	dBm
	802.11g	--	-1	--	dBm
	MCS0-7	--	-1	--	dBm
Receiver adjacent channel interference rejection (ACI) 802.11b	1 Mbit/s	--	38	--	dB
	2 Mbit/s	--	39	--	dB
	5.5 Mbit/s	--	43	--	dB
	11 Mbit/s	--	47	--	dB
Receiver adjacent channel interference rejection (ACI) 802.11g	6 Mbit/s	--	33	--	dB
	9 Mbit/s	--	33	--	dB
	12 Mbit/s	--	32	--	dB
	18 Mbit/s	--	30	--	dB
	24 Mbit/s	--	29	--	dB
	36 Mbit/s	--	27	--	dB
	48 Mbit/s	--	22	--	dB
	54 Mbit/s	--	19	--	dB
Receiver adjacent channel interference rejection (ACI) 802.11n, HT20	MCS0	--	33	--	dB
	MCS1	--	32	--	dB
	MCS2	--	30	--	dB
	MCS3	--	27	--	dB
	MCS4	--	24	--	dB
	MCS5	--	19	--	dB
	MCS6	--	18	--	dB
	MCS7	--	17	--	dB

9.3.3 5 GHz Wi-Fi receiver performance

Note: Unless otherwise stated, all specifications are at 25°C, nominal voltage, averaged over one channel per sub-band, averaged over the antenna path, and at the chip port.

Table 28. 5 GHz Wi-Fi receiver performance

Parameter	Conditions	Min	Typ	Max	Unit
RF frequency range	5 GHz—IEEE 802.11n/a	4900	--	5925	MHz
Receiver input IP3 at RF high gain (in-band) ^[1]	Receiver Input IP3 when LNA in high gain mode (24 dB) at chip input	--	-20	--	dBm
Receiver sensitivity 802.11a	6 Mbit/s	--	-92	--	dBm
	9 Mbit/s	--	-92	--	dBm
	12 Mbit/s	--	-91	--	dBm
	18 Mbit/s	--	-89	--	dBm
	24 Mbit/s	--	-86	--	dBm
	36 Mbit/s	--	-83	--	dBm
	48 Mbit/s	--	-79	--	dBm
	54 Mbit/s	--	-77	--	dBm
Receiver sensitivity 802.11n HT20 (with BCC)	MCS0	--	-92	--	dBm
	MCS1	--	-90	--	dBm
	MCS2	--	-88	--	dBm
	MCS3	--	-85	--	dBm
	MCS4	--	-82	--	dBm
	MCS5	--	-77	--	dBm
	MCS6	--	-76	--	dBm
	MCS7	--	-74	--	dBm
Receiver sensitivity 802.11n HT40 (with BCC)	MCS0	--	-89	--	dBm
	MCS1	--	-87	--	dBm
	MCS2	--	-86	--	dBm
	MCS3	--	-83	--	dBm
	MCS4	--	-79	--	dBm
	MCS5	--	-75	--	dBm
	MCS6	--	-73	--	dBm
	MCS7	--	-72	--	dBm
Receiver maximum input level 802.11	802.11a	--	-3	--	dBm
	MCS0-7	--	-3	--	dBm
Receiver adjacent channel interference rejection (ACI) 802.11a	6 Mbit/s	--	30	--	dB
	9 Mbit/s	--	29	--	dB
	12 Mbit/s	--	29	--	dB
	18 Mbit/s	--	26	--	dB

Table 28. 5 GHz Wi-Fi receiver performance...continued

Parameter	Conditions	Min	Typ	Max	Unit
Receiver adjacent channel interference rejection (ACI) 802.11a (continued)	24 Mbit/s	--	26	--	dB
	36 Mbit/s	--	19	--	dB
	48 Mbit/s	--	16	--	dB
	54 Mbit/s	--	13	--	dB
Receiver adjacent channel interference rejection (ACI) 802.11n HT20	MCS0	--	30	--	dB
	MCS1	--	28	--	dB
	MCS2	--	26	--	dB
	MCS3	--	24	--	dB
	MCS4	--	18	--	dB
	MCS5	--	14	--	dB
	MCS6	--	13	--	dB
	MCS7	--	9	--	dB

[1] Excludes an external LNA nominal gain of 16 dB. Gain can be extended if external LNA is not used.

9.3.4 2.4 GHz Wi-Fi transmitter performance

Note: Unless otherwise stated, all specifications are at 25°C, nominal voltage, and at the chip port.

Table 29. 2.4 GHz Wi-Fi transmitter performance

Parameter	Conditions	Min	Typ	Max	Unit
RF frequency range	2.4 GHz—IEEE 802.11n/g/b	2400	--	2500	MHz
Transmit output saturation	Saturation power at chip output port	--	27	--	dBm
Transmit carrier suppression (CW)	Carrier suppression at chip output port	--	-36	--	dB
Transmit I/Q suppression with IQ calibration	I/Q suppression at chip output port	--	-45	--	dBc
Transmit power (EVM and mask compliant) 20 MHz per chain	802.11b	--	20	--	dBm
	OFDM BPSK	--	20	--	dBm
	OFDM QPSK	--	20	--	dBm
	OFDM 16-QAM	--	20	--	dBm
	OFDM 64-QAM (MCS7)	--	19	--	dBm
Transmit power (EVM and mask compliant) 40 MHz per chain	OFDM 64-QAM (MCS7)	--	18	--	dBm
Transmit output power level control range	--	--	20 ^[1]	--	dB
Transmit output power control step	--	--	1 ^[2]	--	dB
Transmit Carrier suppression	802.11b, 11 Mbit/s at 19 dBm, bandwidth = 20 MHz	--	37	--	dB

[1] 0-20 dB

[2] Hardware capability = 0.5 dB, software capability = 1 dB

9.3.5 5 GHz Wi-Fi transmitter performance

Note: Unless otherwise stated, all specifications are at 25°C, nominal voltage, and at the chip port.

Table 30. 5 GHz Wi-Fi transmitter performance

Parameter	Conditions	Min	Typ	Max	Unit
RF frequency range	5 GHz—IEEE 802.11n/a	4900	--	5925	MHz
Transmit output saturation	Saturation power at chip output	--	27	--	dBm
Transmit carrier suppression (CW)	Carrier suppression at chip output	--	-36	--	dB
Transmit I/Q suppression with IQ calibration	I/Q suppression at chip output	--	-45	--	dBc
Transmit power (EVM and mask compliant) 20 MHz per chain	OFDM BPSK	--	19	--	dBm
	OFDM QPSK	--	19	--	dBm
	OFDM 16-QAM	--	19	--	dBm
	OFDM 64-QAM (MCS7)	--	18	--	dBm
Transmit power (EVM and mask compliant) 40 MHz per chain	OFDM 64-QAM (MCS7)	--	17	--	dBm
Transmit output power level control range	--	--	20 ^[1]	--	dB
Transmit output power control step	--	--	1 ^[2]	--	dB
Transmit carrier suppression	802.11n MCS7 HT40, at 15 dBm	--	46	--	dBc

[1] 0-20 dBm

[2] Hardware capability = 0.5 dB, software capability = 1 dB

9.3.6 Local oscillator

Table 31. Local oscillator

Parameter	Condition	Min	Typ	Max	Unit
Phase noise	Measured at 2.438 GHz at 100 kHz offset	--	-103	--	dBc/Hz
	Measured at 5.501 GHz at 100 kHz offset	--	-100	--	dBc/Hz
Integrated RMS phase noise at RF output (from 10 kHz–10 MHz)	Reference clock frequency = 26 MHz (2.4 GHz)	--	0.35	--	degrees
	Reference clock frequency = 26 MHz (5 GHz)	--	0.65	--	degrees
Frequency resolution	--	0.02	--	--	kHz

9.4 Bluetooth radio specifications

The Bluetooth radio interface pin is powered by AVDD18 voltage supply.

9.4.1 Bluetooth/Bluetooth LE receiver performance

Note: Unless otherwise stated, all specifications are at 25°C, nominal voltage, and at chip port.

Table 32. Bluetooth/Bluetooth LE receiver performance

Parameter	Conditions	Min	Typ	Max	Unit
RF frequency range	--	2.4	--	2.5	GHz
IF frequency	--	--	1.5	--	MHz
Input IP3 (at maximum gain of 72 dB)	--	--	-19	--	dBm
In-band blocking	GFSK C/I (Co-channel)	--	10	--	dB
	C/I (1 MHz)	--	-4	--	dB
	C/I (2 MHz)	--	-45	--	dB
	C/I (3 MHz)	--	-49	--	dB
	C/I (Image)	--	-21	--	dB
	C/I (Image ±1 MHz)	--	-32	--	dB
	Pi/4-DQPSK C/I (Co-channel)	--	10	--	dB
	C/I (1 MHz)	--	-9	--	dB
	C/I (2 MHz)	--	-47	--	dB
	C/I (3 MHz)	--	-51	--	dB
	C/I (Image)	--	-19	--	dB
	C/I (Image ±1 MHz)	--	-35	--	dB
	8-DPSK C/I (Co-channel)	--	16	--	dB
	C/I (1 MHz)	--	-6	--	dB
	C/I (2 MHz)	--	-42	--	dB
	C/I (3 MHz)	--	-48	--	dB
	C/I (Image)	--	-12	--	dB
	C/I (Image ±1 MHz)	--	-33	--	dB
	Out-of-band blocking	30–2000 MHz	--	-12.5	--
2–2.399 GHz		--	-12.4	--	dBm
2.484–3 GHz		--	-18	--	dBm
3–12.75 GHz		--	-2.6	--	dBm
RSSI Range	Resolution = 1 dB	--	-90	0	dBm

Table 32. Bluetooth/Bluetooth LE receiver performance...continued

Parameter	Conditions	Min	Typ	Max	Unit
Sensitivity (RCV/CA/01/C, RCV/CA/02/C, and RCV/CA/07/C)	DH5	--	-96	--	dBm
	2DH5	--	-96	--	dBm
	3DH5	--	-89	--	dBm
Sensitivity (RCV-LE/CA/02/C)	LE 1 Mbit/s	--	-99	--	dBm

9.4.2 Bluetooth/Bluetooth LE transmitter performance

Note: Unless otherwise stated, all specifications are at 25°C, nominal voltage, and across frequency.

Table 33. Bluetooth/Bluetooth LE transmitter performance

Parameter	Conditions	Min	Typ	Max	Unit
RF frequency range	--	2.4	--	2.5	GHz
Output power @pin	Class 1 without external PA—BDR	--	+13	--	dBm
	Class 1 without external PA—EDR	--	+10	--	dBm
Gain range	Class 1 without external PA	--	30	--	dB
Gain resolution	--	--	0.5	--	dB
Spurious emission (BDR) (in-band)	±500 kHz	--	--	-20	dBc
	±2 MHz	--	-33	-20	dBm
	±3 MHz	--	-45	-40	dBm
Spurious emission (EDR) (in-band)	±1 MHz	--	--	-26	dBc
	±1.5 MHz	--	--	-20	dBm
	±2.5 MHz	--	--	-40	dBm
Spurious emission (out-of-band)	30–88 MHz	--	-65	-41.25	dBm
	88–960 MHz	--	-65	-41.25	
	0.96–20 GHz All frequencies in this range < -41.25 dBm, except at 2x Bluetooth channel frequency. Measured at pin without external filter.	--	-35	-25	
	Restricted—2.38–2.39 GHz	--	-55	-41.25	
	Restricted—2.4835–2.6 GHz	--	-50	-41.25	
Out-of-band/ Cellular band noise	GSM850 (869–894 MHz)	--	-140	--	dBm/Hz
	GSM900 (925–960 MHz)	--	-140	--	
	GSM DCS (1805–1880 MHz)	--	-135	--	
	GSM PCS (1930–1990 MHz)	--	-135	--	
	GPS (1575.42 ±1.023 MHz)	--	-140	--	
	WCDMA Band I (2110–2170 MHz)	--	-130	--	
	WCDMA Band V (869–894 MHz)	--	-140	--	
Transmit output power (TRM/CA/01/C)	DH5	--	13	--	dBm
Power control (TRM/CA/03/C)	--	--	4	--	dB
Frequency range (TRM/CA/04/C)	Freq Low	--	2400.9	--	MHz
	Freq High	--	2481.1	--	MHz
-20 dB bandwidth (TRM/CA/05/C)	DH5	--	955	--	MHz

Table 33. Bluetooth/Bluetooth LE transmitter performance...continued

Parameter	Conditions	Min	Typ	Max	Unit
Modulation characteristics (TRM/CA/07/C)	Delta F1 avg	--	165	--	kHz
	Delta F2 max Threshold	--	100	--	%
	Delta F2/Delta F1	--	0.9	--	--
	Delta F2 avg	--	145	--	kHz
ICFT (TRM/CA/08/C)	DH1	--	2	--	kHz
Carrier frequency drift (TRM/CA/09/C)	Max Drift - DH1	--	-3.5	--	kHz
	Drift Rate - DH1	--	1	--	kHz
	Max Drift - DH3	--	-4.5	--	kHz
	Drift Rate - DH3	--	1.5	--	kHz
	Max Drift - DH5	--	-5	--	kHz
	Drift Rate - DH5	--	1.5	--	kHz
EDR relative power (TRM/CA/10/C)	2DH5 (DPSK/GFSK)	--	-0.1	--	dB
	3DH5 (DPSK/GFSK)	--	-0.1	--	dB
EDR carrier frequency stability and modulation accuracy (TRM/CA/11/C)	2DH5 Peak DEVM	--	13	--	%
	2DH5 RMS DEVM	--	5	--	%
	3DH5 Peak DEVM	--	15	--	%
	3DH5 RMS DEVM	--	6	--	%
Diff. phase encoding (TRM/CA/12/C)	2DH5	--	100	--	%
	3DH5	--	100	--	%
Bluetooth LE output power (TRM/-LE/CA/01/C)	Bluetooth LE 1 Mbit/s	--	5	--	dBm
Bluetooth LE modulation characteristics (TRM-LE/CA/05/C)	Delta F1 avg - Bluetooth LE 1 Mbit/s	--	244	--	kHz
	Delta F2/Delta F1 Bluetooth LE 1 Mbit/s	--	0.9	--	kHz
	Delta F2 avg - Bluetooth LE 1 Mbit/s	--	222	--	kHz
Bluetooth LE carrier frequency drift (TRM-LE/CA/06/C)	Max Drift - Bluetooth LE 1 Mbit/s	--	1.5	--	kHz
	Drift Rate - Bluetooth LE 1 Mbit/s	--	1	--	kHz
Frequency accuracy (TRM-LE/CA/BV-06-C)	Bluetooth LE 1 Mbit/s	--	-3.5	--	kHz

9.5 Current consumption

Note: Unless otherwise stated, all specifications are at 25°C, nominal voltage, across frequency, and at chip output port for transmit data is collected from SDIO-SDIO host interface configuration.

Table 34. Current consumption

Mode	Conditions	2.2V	1.8V	1.1V	Unit
Sleep mode	Power down	0	0.002	0.001	mA
	Wi-Fi and Bluetooth in deep sleep mode	0.001	0.01	0.291	mA
	Bluetooth only in deep sleep mode	0.001	0.01	0.195	mA
	Bluetooth LE only in deep sleep mode	0.001	0.01	0.153	mA
Bluetooth LE (Wi-Fi in deep sleep mode)	Bluetooth LE link (master mode, interval=1.28s)	0.001	0.064	0.232	mA
	Bluetooth LE peak transmit (at 0 dBm), 1 Mbit/s	0.001	16	30	mA
	Bluetooth LE peak receive, 1 Mbit/s	0.001	18	15	mA
	Bluetooth LE advertise(interval=1.28s)	0.001	0.047	0.197	mA
	Bluetooth LE scan (interval = 1.28s, window = 11.25 ms)	0.001	0.154	0.28	mA
Bluetooth (Wi-Fi in deep sleep mode)	Bluetooth page scan	0.001	0.203	0.495	mA
	Bluetooth page and inquiry scan	0.001	0.353	0.622	mA
	Bluetooth ACL link, master sniff mode, (interval = 1.28s)	0.001	0.078	0.427	mA
	Bluetooth ACL link, master sniff mode, (interval=500ms)	0.001	0.193	0.604	mA
	Bluetooth ACL (data pump) DH1	0.001	10	17	mA
	Bluetooth ACL (data pump) 3-DH5	0.001	23	14	mA
	Bluetooth SCO HV3 peak transmit (at device maximum power)	0.001	88	14	mA
	Bluetooth SCO HV3 peak Rx	0.001	18	15	mA
	Bluetooth SCO HV3 Peak transmit (at 4 dBm)	0.001	17	37	mA
IEEE power save (Beacon interval: 100 msec)	IEEE-PS_2GHz-Legacy (DTIM-1)	0.001	0.916	0.886	mA
	IEEE-PS_2GHz-Legacy (DTIM-3)	0.001	0.42	0.502	mA
	IEEE-PS_2GHz-Legacy (DTIM-5)	0.001	0.274	0.439	mA
2.4 GHz Wi-Fi receive (Bluetooth in deep sleep mode)	802.11b, 11 Mbit/s, 1x1	0.005	36	24	mA
	802.11g, 54 Mbit/s, 1x1	0.005	37	32	mA
	802.11n, HT20 MCS7, 1x1	0.005	35	40	mA
5 GHz Wi-Fi receive (Bluetooth in deep sleep mode)	802.11a, 54 Mbit/s, 1x1	0.005	53	32	mA
	802.11n, HT20 MCS7, 1x1	0.005	52	40	mA
	802.11n, HT40 MCS7, 1x1	0.005	60	53	mA

Table 34. Current consumption...continued

Mode	Conditions	2.2V	1.8V	1.1V	Unit
2.4 GHz Wi-Fi transmit	802.11b, 11 Mbit/s at 16 dBm, 1x1	225	93	83	mA
	802.11g, 54 Mbit/s at 15 dBm, 1x1	185	91	95	mA
	802.11n, HT20 MCS7 at 14 dBm, 1x1	164	90	97	mA
5 GHz Wi-Fi transmit	802.11a, 54 Mbit/s at 15 dBm, 1x1	186	147	98	mA
	802.11n, HT20 MCS7 at 15 dBm, 1x1	185	148	105	mA
	802.11n, HT40 MCS7 at 14 dBm, 1x1	168	148	114	mA
Current consumption during device initialization	Max current consumption during device initialization	950	254	150	mA

9.6 Coexistence specifications

The 88W8977 MWS coexistence interface pins are powered by VIO voltage supply. Refer to the MWS standard for additional interface specifications.

See [Section 9.1.1 "VIO DC characteristics"](#) for specifications.

9.7 SDIO host interface specifications

The SDIO host interface pins are powered by VIO_SD voltage supply.

The SDIO electrical specifications are identical for 4-bit SDIO and 1-bit SDIO transfer modes.

9.7.1 VIO_SD DC characteristics

9.7.1.1 1.8V operation

Table 35. DC electricals—1.8V operation (VIO_SD)

Symbol	Parameter	Condition	Min	Typ	Max	Unit
V _{IH}	Input high voltage	--	0.7*VIO_SD	--	VIO_SD+0.4	V
V _{IL}	Input low voltage	--	-0.4	--	0.3*VIO_SD	V
V _{HYS}	Input hysteresis	--	100	--	--	mV
V _{OH}	Output high voltage	--	VIO_SD-0.4	--	--	V
V _{OL}	Output low voltage	--	--	--	0.4	V

9.7.1.2 3.3V operation

Table 36. DC electricals—3.3V operation (VIO_SD)

Symbol	Parameter	Condition	Min	Typ	Max	Unit
V _{IH}	Input high voltage	--	0.7*VIO_SD	--	VIO_SD+0.4	V
V _{IL}	Input low voltage	--	-0.4	--	0.3*VIO_SD	V
V _{HYS}	Input hysteresis	--	100	--	--	mV
V _{OH}	Output high voltage	--	VIO_SD-0.4	--	--	V
V _{OL}	Output low voltage	--	--	--	0.4	V

9.7.2 Default speed mode and high-speed mode

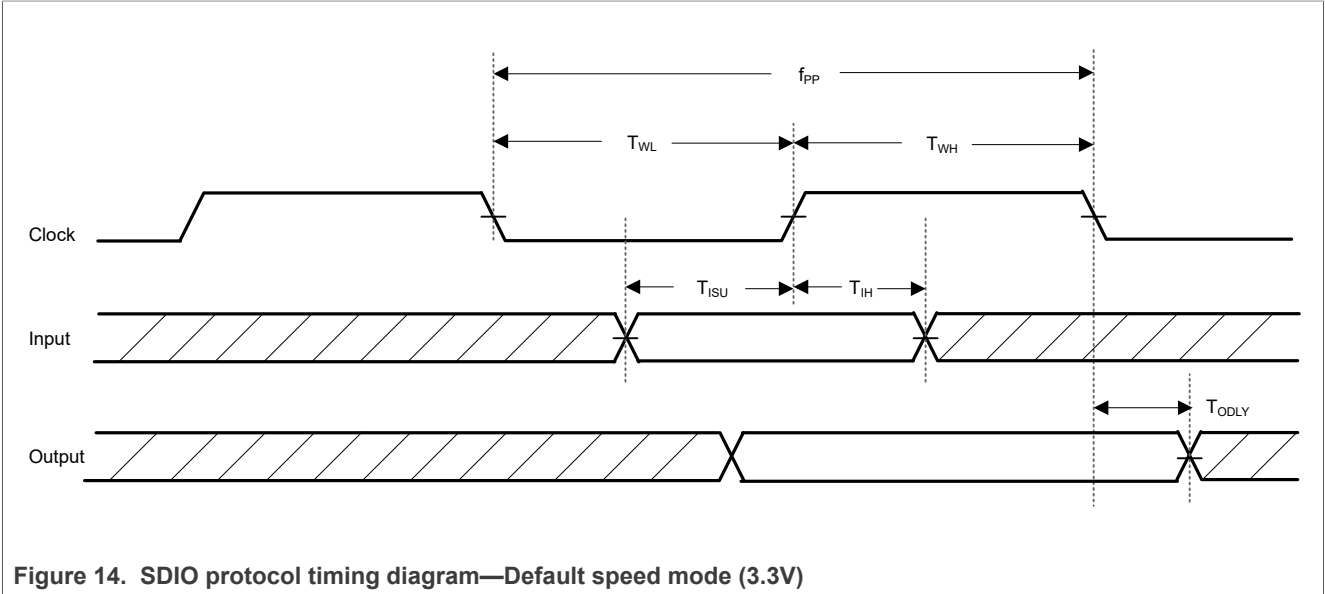

Figure 14. SDIO protocol timing diagram—Default speed mode (3.3V)

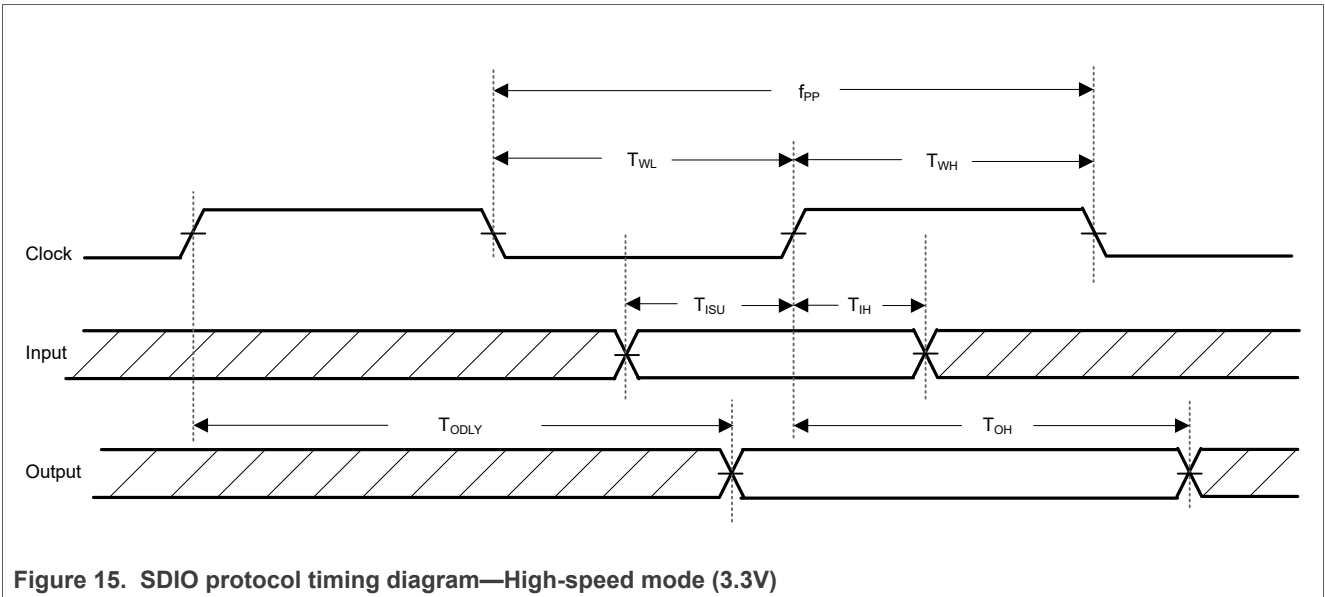

Figure 15. SDIO protocol timing diagram—High-speed mode (3.3V)

Table 37. SDIO timing data—Default speed mode and high-speed modes (3.3V)^{[1], [2]}

Over full range of values specified in the Recommended Operating Conditions unless otherwise specified.

Symbol	Parameter	Condition	Min	Typ	Max	Unit
f _{PP}	Clock frequency	Normal	0	--	25	MHz
		High-speed	0	--	50	MHz
T _{WL}	Clock low time	Normal	10	--	--	ns
		High-speed	7	--	--	ns
T _{WH}	Clock high time	Normal	10	--	--	ns
		High-speed	7	--	--	ns
T _{ISU}	Input setup time	Normal	5	--	--	ns
		High-speed	6	--	--	ns
T _{IH}	Input hold time	Normal	5	--	--	ns
		High-speed	2	--	--	ns
T _{ODLY}	Output delay time	Normal	--	--	14	ns
	CL ≤ 40 pF (1 card)	High-speed	--	--	14	ns
T _{OH}	Output hold time	High-speed	2.5	--	--	ns

[1] For SDIO 2.0 running at 50 MHz clock frequency, only 1.8V is supported.

[2] For SDIO 2.0 running at 25 MHz clock frequency, 1.8V or 3.3V is supported.

9.7.3 SDR12, SDR25, SDR50 modes (up to 100 MHz) (1.8V)

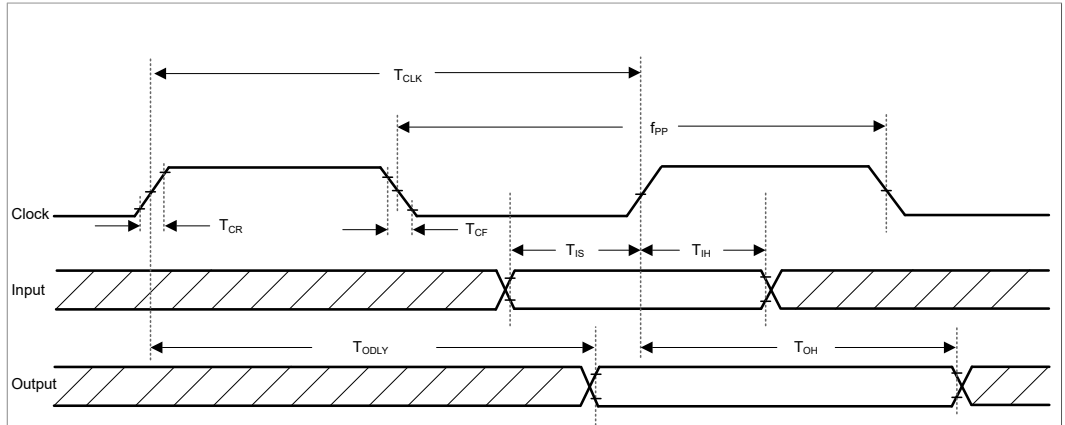

Figure 16. SDIO protocol timing diagram—SDR12, SDR25, SDR50 modes (up to 100 MHz) (1.8V)

Table 38. SDIO timing data—SDR12, SDR25, SDR50 modes (up to 100 MHz) (1.8V)

Over full range of values specified in the Recommended Operating Conditions unless otherwise specified.

Symbol	Parameter	Condition	Min	Typ	Max	Unit
f_{PP}	Clock frequency	SDR12/25/50	25	--	100	MHz
T_{IS}	Input setup time	SDR12/25/50	3	--	--	ns
T_{IH}	Input hold time	SDR12/25/50	0.8	--	--	ns
T_{CLK}	Clock time	SDR12/25/50	10	--	40	ns
T_{CR}, T_{CF}	Rise time, fall time $T_{CR}, T_{CF} < 2$ ns (max) at 100 MHz $C_{CARD} = 10$ pF	SDR12/25/50	--	--	$0.2 \cdot T_{CLK}$	ns
T_{ODLY}	Output delay time $C_L \leq 30$ pF	SDR12/25/50	--	--	7.5	ns
T_{OH}	Output hold time $C_L = 15$ pF	SDR12/25/50	1.5	--	--	ns

9.7.4 DDR50 Mode (50 MHz) (1.8V)

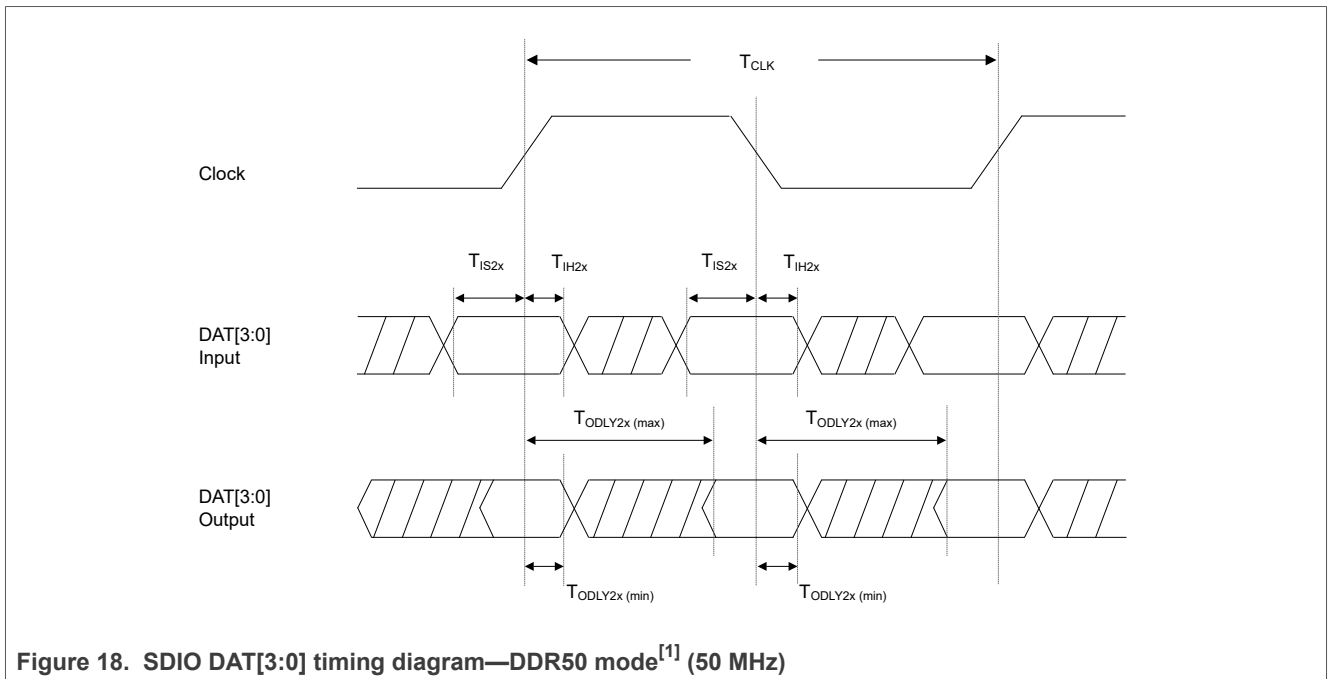
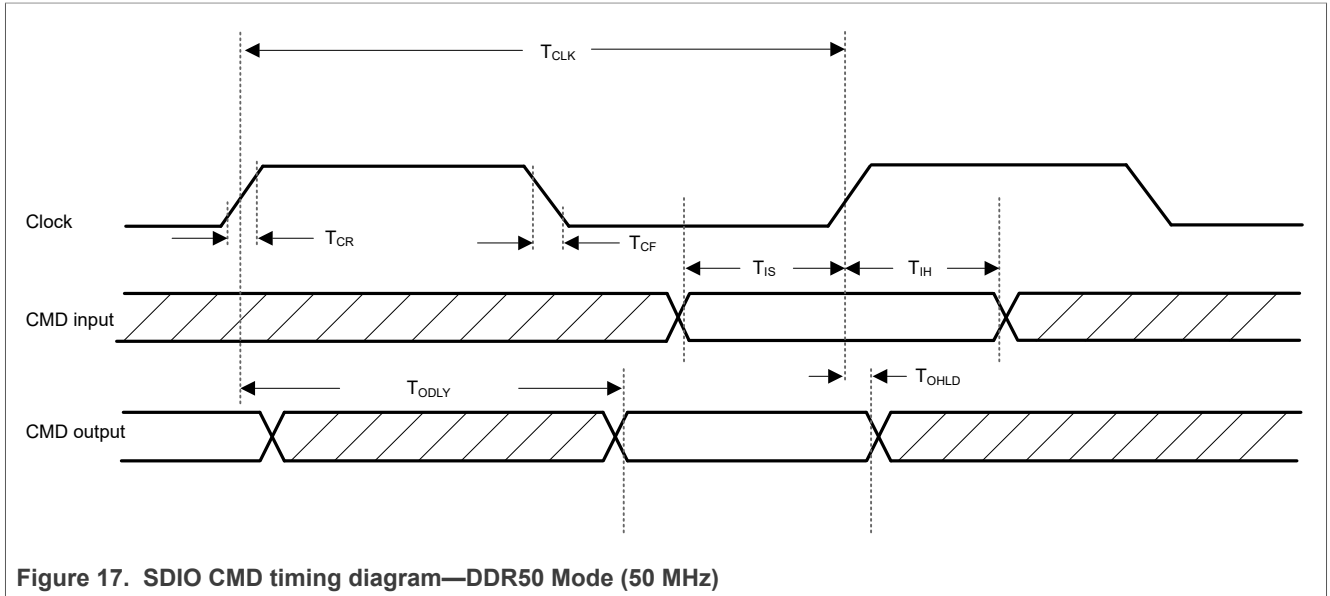

[1] In DDR50 mode, DAT[3:0] lines are sampled on both edges of the clock (not applicable for CMD line).

Table 39. SDIO timing data—DDR50 mode (50 MHz)

Over full range of values specified in the Recommended Operating Conditions unless otherwise specified.

Symbol	Parameter	Condition	Min	Typ	Max	Unit
Clock						
T _{CLK}	Clock time 50 MHz (max) between rising edges	DDR50	20	--	--	ns
T _{CR} , T _{CF}	Rise time, fall time T _{CR} , T _{CF} < 4.00 ns (max) at 50 MHz C _{CARD} = 10 pF	DDR50	--	--	0.2*T _{CLK}	ns
Clock Duty	--	DDR50	45	--	55	%
CMD Input (referenced to clock rising edge)						
T _{IS}	Input setup time C _{CARD} ≤ 10 pF (1 card)	DDR50	6	--	--	ns
T _{IH}	Input hold time C _{CARD} ≤ 10 pF (1 card)	DDR50	0.8	--	--	ns
CMD Output (referenced to clock rising edge)						
T _{ODLY}	Output delay time during data transfer mode C _L ≤ 30 pF (1 card)	DDR50	--	--	13.7	ns
T _{OHLd}	Output hold time C _L ≥ 15 pF (1 card)	DDR50	1.5	--	--	ns
DAT[3:0] Input (referenced to clock rising and falling edges)						
T _{IS2x}	Input setup time C _{CARD} ≤ 10 pF (1 card)	DDR50	3	--	--	ns
T _{IH2x}	Input hold time C _{CARD} ≤ 10 pF (1 card)	DDR50	0.8	--	--	ns
DAT[3:0] Output (referenced to clock rising and falling edges)						
T _{ODLY2x} (max)	Output delay time during data transfer mode C _L ≤ 25 pF (1 card)	DDR50	--	--	7.0	ns
T _{ODLY2x} (min)	Output hold time C _L ≥ 15 pF (1 card)	DDR50	1.5	--	--	ns

9.8 UART interface specifications

The UART transmit and receive pins are powered by VIO voltage supply.

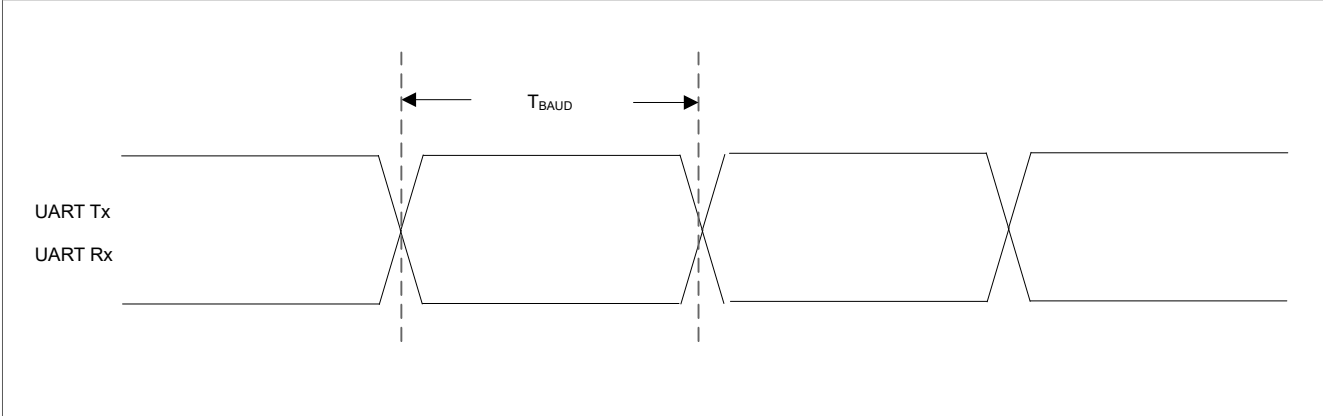

Figure 19. Figure Caption

Table 40. UART timing data^[1]

Over full range of values specified in the Recommended Operating Conditions unless otherwise specified.

Symbol	Parameter	Condition	Min	Typ	Max	Unit
T _{BAUD}	Baud rate	26 MHz input clock	250	--	--	ns

[1] The acceptable deviation from the UART Rx target baud rate is ±3%.

9.9 PCM interface specifications

The PCM pins are powered by VIO voltage supply.

See [Section 9.1.1 "VIO DC characteristics"](#) for specifications.

Table 41. PCM timing specification diagram for data signals—Master mode

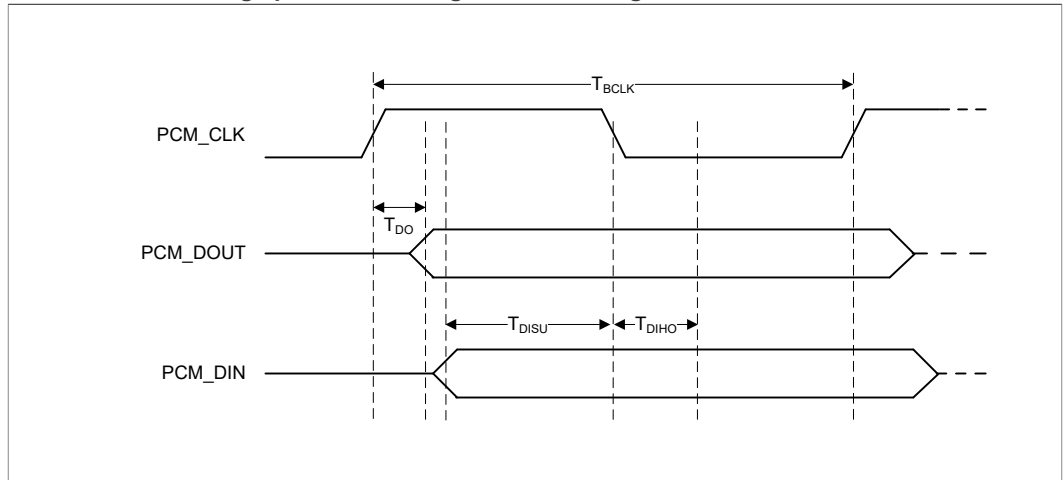

Table 42. PCM timing specification diagram for sync signal—Master mode

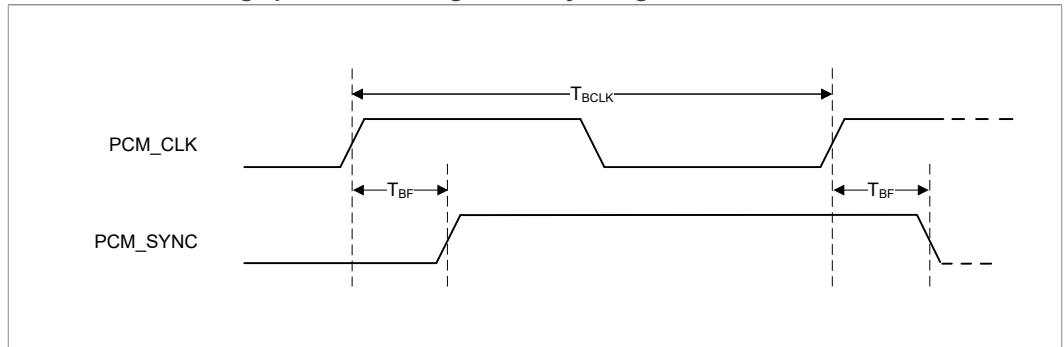

Table 43. PCM timing specification data—Master mode

Symbol	Parameter	Condition	Min	Typ	Max	Unit
F_{BCLK}	Bit clock frequency	--	--	2/2.048	--	MHz
Duty Cycle $_{BCLK}$	Bit clock duty cycle	--	0.4	0.5	0.6	--
$T_{BCLK\ rise/fall}$	PCM_CLK rise/fall time	--	--	3	--	ns
T_{DO}	Delay from PCM_CLK rising edge to PCM_DOUT rising edge	--	--	--	15	ns
T_{DISU}	Setup time for PCM_DIN before PCM_CLK falling edge	--	20	--	--	ns
T_{DIHO}	Hold time for PCM_DIN after PCM_CLK falling edge	--	15	--	--	ns
T_{BF}	Delay from PCM_CLK rising edge to PCM_SYNC rising edge	--	--	--	15	ns

Table 44. PCM timing specification diagram for data signals—Slave mode

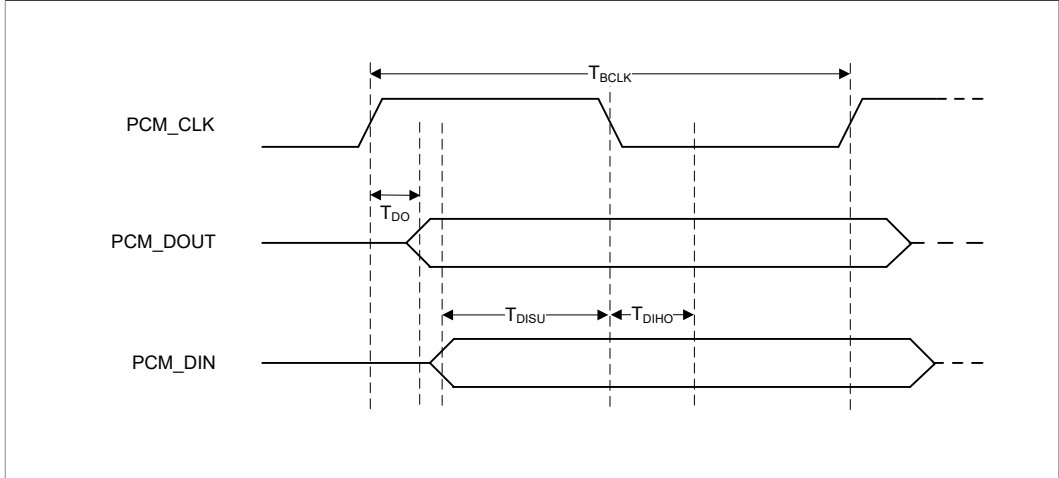

Table 45. PCM timing specification diagram for sync signal—Slave mode

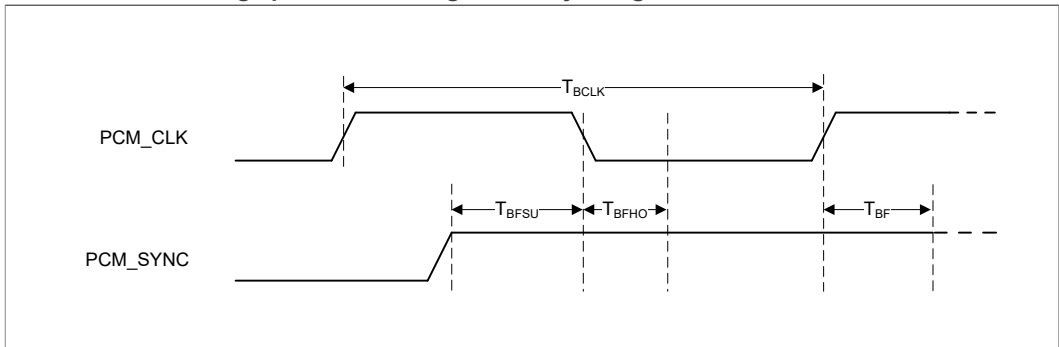

Table 46. PCM timing specification data—Slave mode

Symbol	Parameter	Condition	Min	Typ	Max	Unit
F_{BCLK}	Bit clock frequency	--	--	2/2.048	--	MHz
Duty Cycle $_{BCLK}$	Bit clock duty cycle	--	0.4	0.5	0.6	--
$T_{BCLK\ rise/fall}$	PCM_CLK rise/fall time	--	--	3	--	ns
T_{DO}	Delay from PCM_CLK rising edge to PCM_DOUT rising edge	--	--	--	30	ns
T_{DISU}	Setup time for PCM_DIN before PCM_CLK falling edge	--	15	--	--	ns
T_{DIHO}	Hold time for PCM_DIN after PCM_CLK falling edge	--	10	--	--	ns
T_{BFSU}	Setup time for PCM_SYNC before PCM_CLK falling edge	--	15	--	--	ns
T_{BFHO}	Hold time for PCM_SYNC after PCM_CLK falling edge	--	10	--	--	ns

9.10 Clock specifications

9.10.1 Single-ended clock input modes

9.10.1.1 2.4 GHz mode

Table 47. CMOS mode^[1]

Symbol	Parameter	Condition	Min	Typ	Max	Unit
V _{IH}	Input high voltage	--	AVDD18 - 0.5	AVDD18	1.98	V
V _{IL}	Input low voltage	--	0	0	0.4	V

[1] Typical input capacitance is approximately 2 pF and input resistance is >20 kΩ.

Table 48. Low-Swing Mode^[1]

Symbol	Parameter	Condition	Min	Typ	Max	Unit
VLS_IH	Single-ended high-level voltage	--	--	--	1.8	V
VLS_IL	Single-ended low-level voltage	--	0	--	--	V
VLS_Amp	Low-swing clock amplitude (pk-pk)	--	0.5	--	--	V
VLS_Slope	Low-swing mid-point slope	--	100	--	--	MV/s
Duty	Duty cycle	--	45	50	55	%

[1] AC-coupling capacitor is integrated into the SoC.

Table 49. Phase Noise—2.4 GHz operation

Parameter	Condition	Min	Typ	Max	Unit
F _{ref} = 26 MHz	Offset = 1 kHz	--	--	-126	dBc/Hz
	Offset = 10 kHz	--	--	-137	dBc/Hz
	Offset = 100 kHz	--	--	-145	dBc/Hz
	Offset > 1 MHz	--	--	-145	dBc/Hz

9.10.1.2 2.4 GHz and 5 GHz dual-band mode

Table 50. Phase noise—Dual-band operation

Parameter	Test Conditions	Min	Typ	Max	Unit
F _{ref} = 26 MHz	Offset = 1 kHz	--	--	-130	dBc/Hz
	Offset = 10 kHz	--	--	-150	dBc/Hz
	Offset = 100 kHz	--	--	-156	dBc/Hz
	Offset > 1 MHz	--	--	-156	dBc/Hz

9.10.2 Crystal

Table 51. Crystal specifications

Parameter	Condition	Typical	Unit
Fundamental frequencies	--	26	MHz
Frequency tolerance	Over operating temperature	< ±10	ppm
	Over process at 25°C	< ±10	ppm
SMD and AT cut height	--	<1.2	mm
Load Capacitance	--	5	pF
Maximum series resistance	--	45	Ω
Resonance mode	--	A1, Fundamental	--

9.10.3 Sleep clock

Table 52. External sleep clock timing

Limited to within 10°C variance.

Symbol	Parameter	Min	Typ	Max	Unit
CLK	Clock frequency range/accuracy • CMOS input clock signal type • ±250 ppm (initial, aging, temperature)	--	32.768	--	kHz
V _{IH}	Input levels, where V _{IO} = 1.8, 2.5, 3.3V	0.7*V _{IO}	--	V _{IO} +0.4	V
V _{IL}	For V _{IH} , V _{IL} , see Section Section 9.1.1 "VIO DC characteristics" .	-0.4	--	0.3*V _{IO}	V
PN	Phase noise requirement (at 100 kHz)	--	-125	--	dBc/ Hz
J _c	Cycle jitter	--	1.5	--	ns (RMS)
SR	Slew rate limit (10-90%)	--	--	100	ns
DC	Duty cycle tolerance	20	--	80	%

9.11 JTAG interface specifications

The JTAG interface pins are powered by VIO voltage supply.

See [Section 9.1.1 "VIO DC characteristics"](#) for specifications.

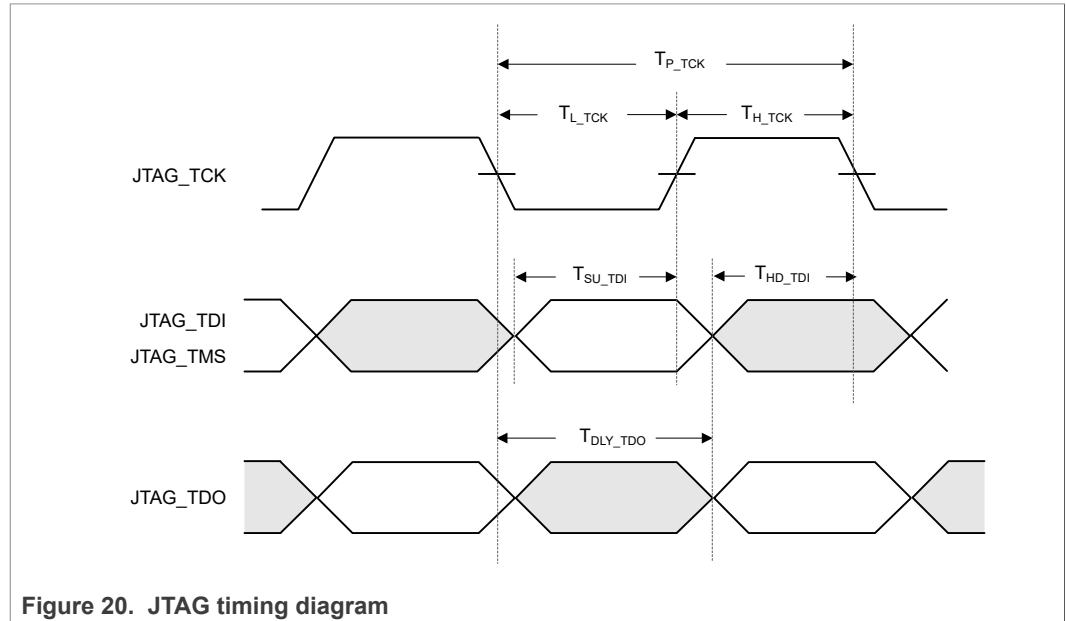

Table 53. JTAG timing data^[1]

Over full range of values specified in the Recommended Operating Conditions unless otherwise specified.

Symbol	Parameter	Condition	Min	Typ	Max	Unit
T_{P_TCK}	TCK period	--	40	--	--	ns
T_{H_TCK}	TCK high	--	12	--	--	ns
T_{L_TCK}	TCK low	--	12	--	--	ns
T_{SU_TDI}	TDI, TMS to TCK setup time	--	10	--	--	ns
T_{HD_TDI}	TDI, TMS to TCK hold time	--	10	--	--	ns
T_{DLY_TDO}	TCK to TDO delay	--	0	--	15	ns

[1] Does not apply to JTAG enabled by the JTAG_TMS pin.

10 Package information

10.1 Package thermal conditions

10.1.1 QFN package thermal conditions

Table 54. Thermal conditions of QFN package

Symbol	Parameter	Condition	Typ	Unit
θ_{JA}	Thermal resistance Junction to ambient of package. $\theta_{JA} = (T_J - T_A) / P$ P = total power dissipation	JEDEC 3 in. x 4.5 in. 4-layer PCB no air flow	28.4	°C/W
		JEDEC 3 in. x 4.5 in. 4-layer PCB 1 meter/sec air flow	27.6	°C/W
		JEDEC 3 in. x 4.5 in. 4-layer PCB 2 meter/sec air flow	26.1	°C/W
		JEDEC 3 in. x 4.5 in. 4-layer PCB 3 meter/sec air flow	25.3	°C/W
ψ_{JT}	Thermal characteristic parameter Junction to top-center of package. $\psi_{JT} = (T_J - T_{TOP}) / P$ T_{TOP} = temperature on top-center of package	JEDEC 3 in. x 4.5 in. 4-layer PCB no air flow	0.44	°C/W
ψ_{JB}	Thermal characteristic parameter Junction to bottom surface, center of PCB. $\psi_{JB} = (T_J - T_B) / P$ T_B = surface temperature of PCB	JEDEC 3 in. x 4.5 in. 4-layer PCB no air flow	15.4	°C/W
θ_{JC}	Thermal resistance Junction to case of the package. $\theta_{JC} = (T_J - T_C) / P_{TOP}$ T_C = temperature on top-center of package P_{TOP} = power dissipation from top of package	JEDEC 3 in. x 4.5 in. 4-layer PCB no air flow	13.0	°C/W
θ_{JB}	Thermal resistance Junction to board of package. $\theta_{JB} = (T_J - T_B) / P_{BOTTOM}$ P_{BOTTOM} = power dissipation from bottom of package to PCB surface	JEDEC 3 in. x 4.5 in. 4-layer PCB no air flow	15.6	°C/W

10.1.2 eWLP package thermal conditions

Table 55. Thermal conditions of eWLP package

Symbol	Parameter	Condition	Typ	Unit
θ_{JA}	Thermal resistance Junction to ambient of package. $\theta_{JA} = (T_J - T_A)/P$ P = total power dissipation	JEDEC 4 in. x 4.5 in. 4-layer PCB no air flow	44.22	°C/W
ψ_{JT}	Thermal characteristic parameter Junction to top-center of package. $\psi_{JT} = (T_J - T_{TOP})/P$ T_{TOP} = temperature on top-center of package	JEDEC 4 in. x 4.5 in. 4-layer PCB no air flow	0.56	°C/W
ψ_{JB}	Thermal characteristic parameter Junction to bottom-center of PCB. $\psi_{JB} = (T_J - T_{BOTTOM})/P$ T_B = temperature on bottom-center of package	JEDEC 4 in. x 4.5 in. 4-layer PCB no air flow	13.93	°C/W

10.2 Package mechanical data

10.2.1 68-pin QFN package mechanical drawing

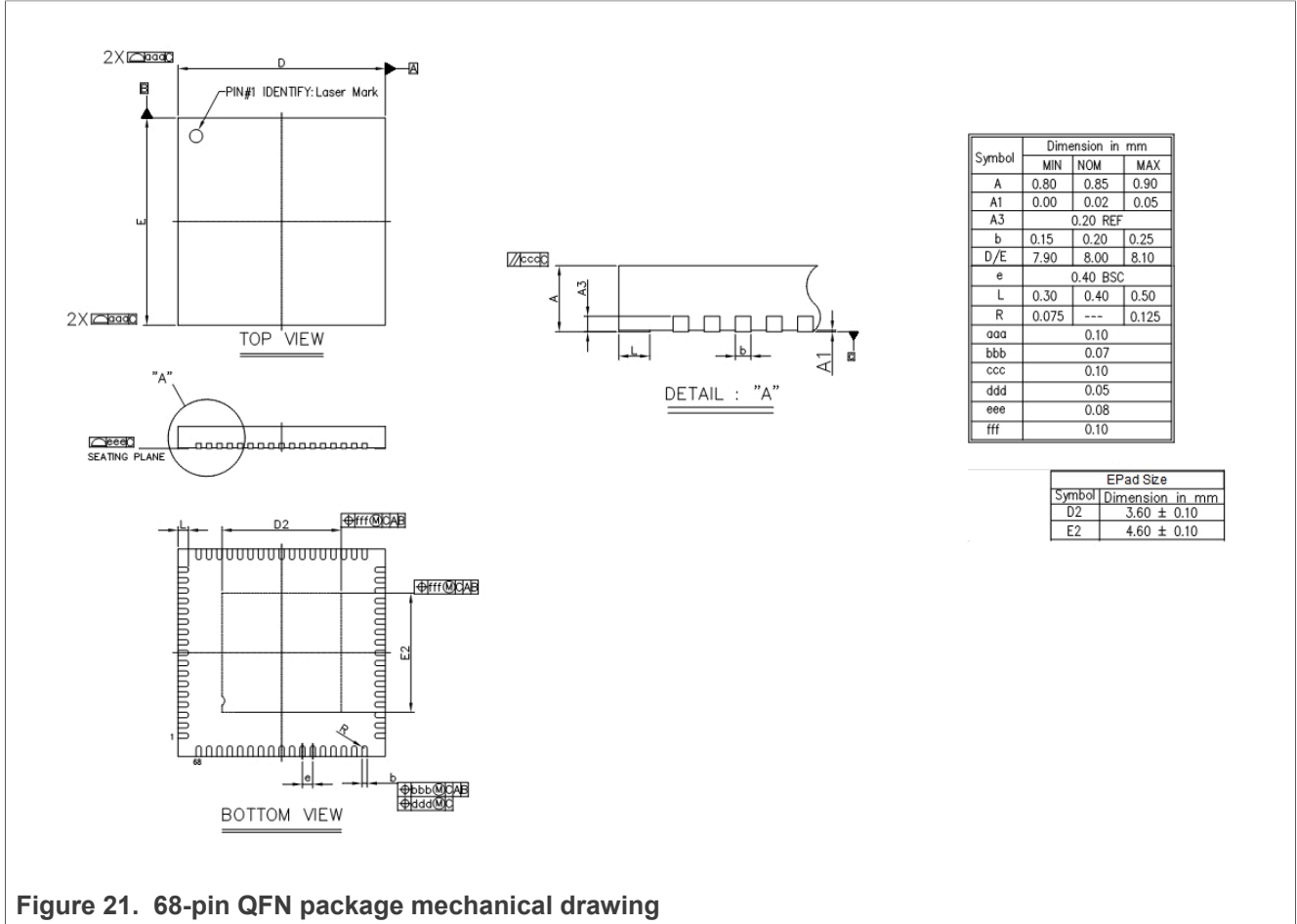

Figure 21. 68-pin QFN package mechanical drawing

10.2.2 74-bump eWLP package mechanical drawing

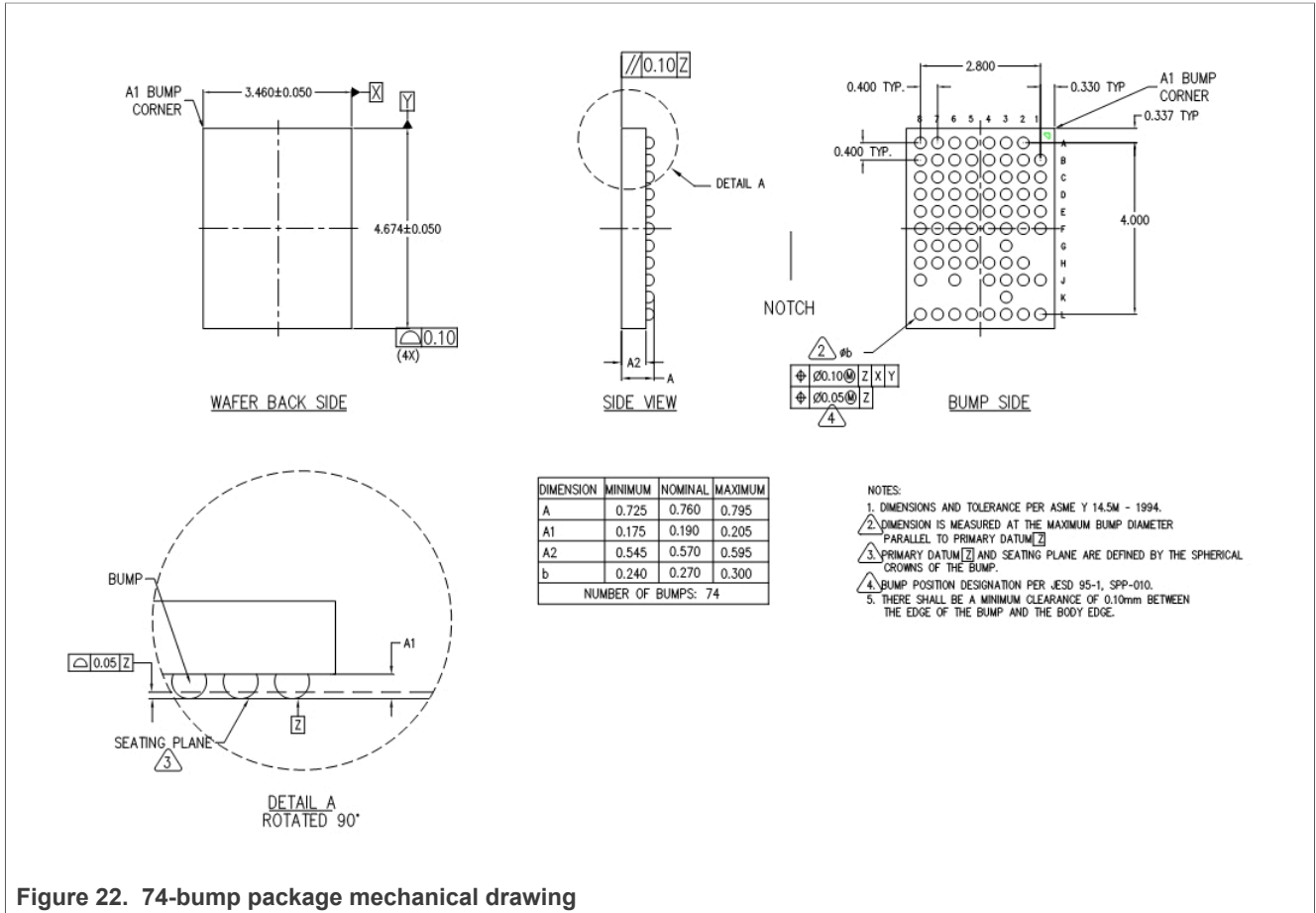
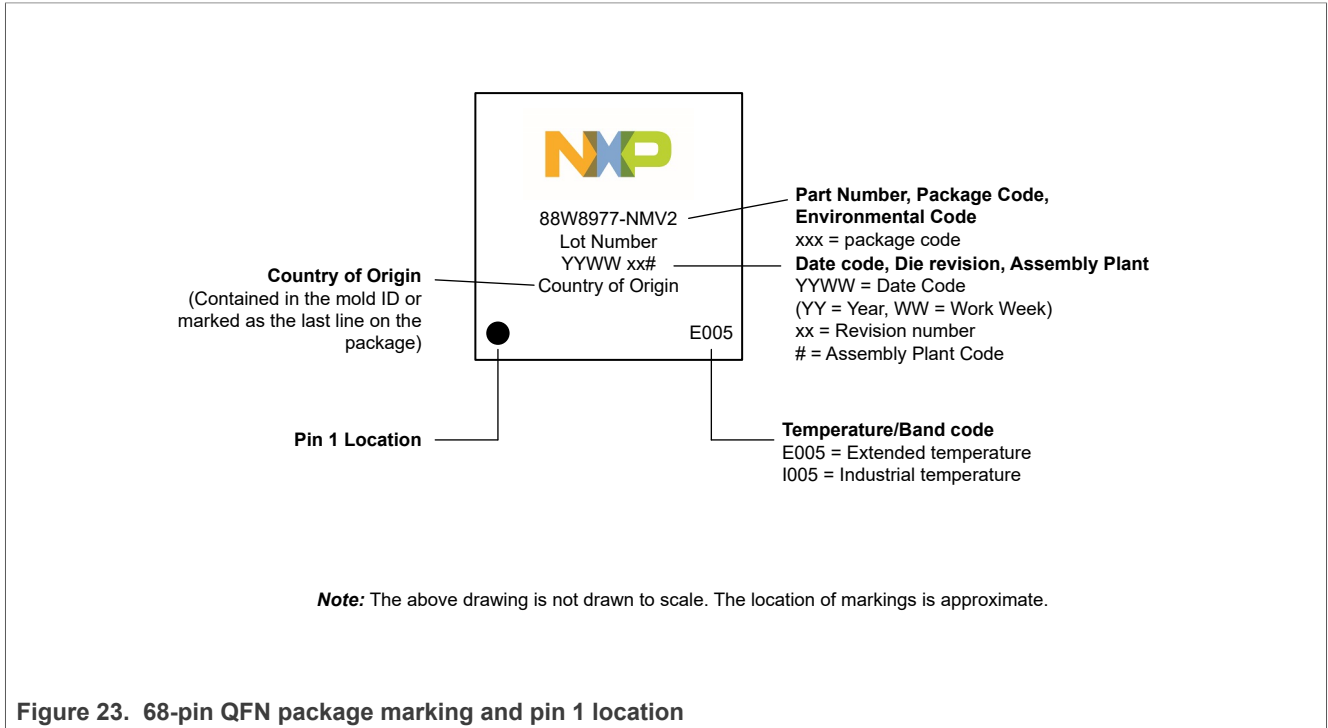

Figure 22. 74-bump package mechanical drawing

10.3 Package marking

10.3.1 68-pin QFN package marking



10.3.2 74-bump eWLP package marking

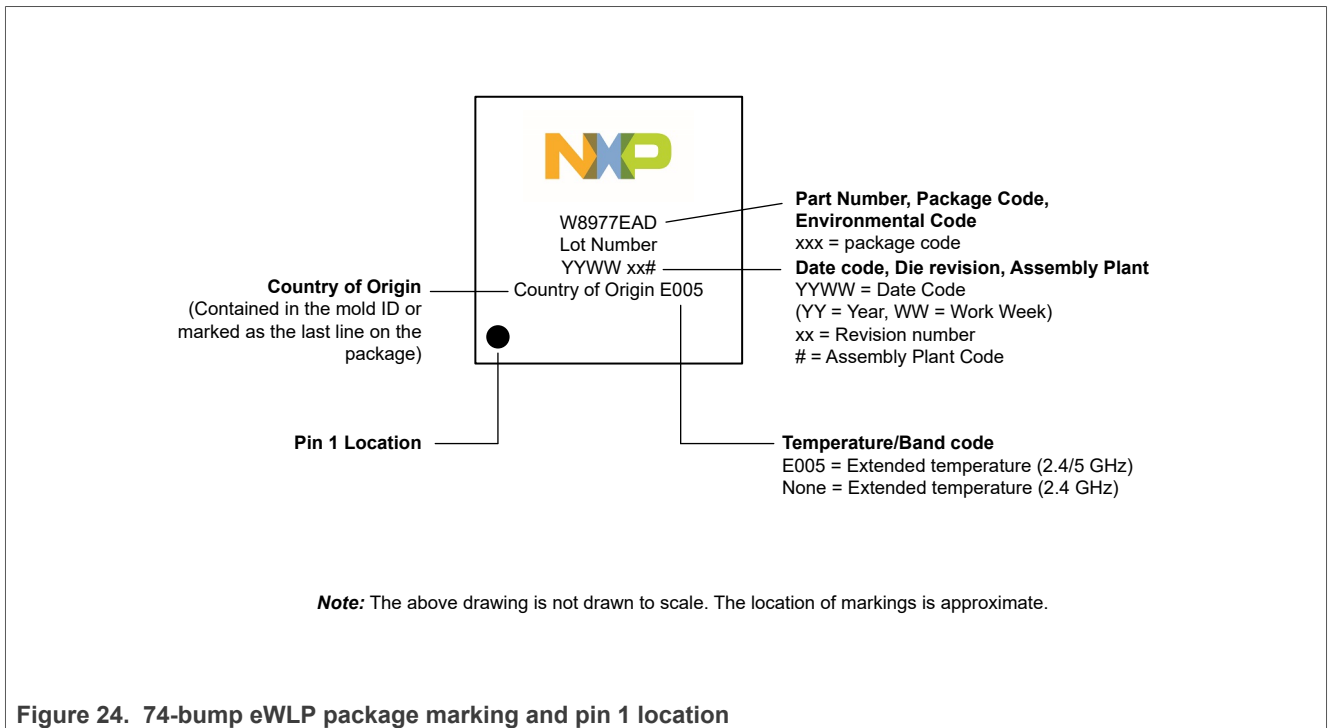

11 Acronyms and abbreviations

Table 56. Acronyms and abbreviations

Acronym	Definition
A2DP	Advanced Audio Distribution Profiles
ABR	Automatic Baud Rate
ACK	Acknowledgment
ADAS	Advanced Driver Assistance Systems
ADC	Analog-to-Digital Converter
AES	Advanced Encryption Standard
AFC	Automatic Frequency Correction
AFH	Adaptive Frequency Hopping
AGC	Automatic Gain Control
AIFS	Arbitration Interframe Space
AoA	Angle of Arrival
AoD	Angle of Departure
AP	Access Point
APB	Advanced Peripheral Bus
API	Application Program Interface
aQFN	Advanced Quad Flat Non-leaded Package
ARM	Advanced RISC Machine
ATIM	Announcement Traffic Indication Message
BAMR	Base Address Mask Register
BAR	Base Address Register
BBU	Baseband Processor Unit
BCB	Benzocyclobutene (flip chip bump process)
BDR	Basic Data Rate
BER	Bit Error Rate
BOM	Bill of Materials
BR	Baud Rate
BSS	Basic Service Set
BSSID	Basic Service Set Identifier
BTU	Bluetooth Baseband Unit
BRF	Bluetooth RF Unit
BWQ	Bandwidth Queue
CBC	Cipher Block Chaining
CBP	Contention-Based Period
CCA	Clear Channel Assessment

Table 56. Acronyms and abbreviations...continued

Acronym	Definition
CCK	Complementary Code Keying
CCMP	Counter Mode CBC-MAC Protocol
CDE	Close Descriptor Enable
CFP	Contention-Free Period
CFQ	Contention-Free Queue
CID	Connection Identifier
CIS	Card Information Structure
CIU	CPU Interface Unit
CMD	Command
CMQ	Control Management Queue
CRC	Cyclic Redundancy Check
CS	Card Select
CSMA/CA	Carrier Sense Multiple Access / Collision Avoidance
CSMA/CD	Carrier Sense Multiple Access / Collision Detection
CSU	Clocked Serial Unit
CTS	Clear to Send
DAC	Digital-to-Analog Converter
DBPSK	Differential Binary Phase Shift Keying
DCD	Device Controller Driver
DCE	Data Communication Equipment
DCF	Distributed Coordination Function
DCLA	Direct Current Level Adjustment
DCLB	Digital Contactless Bridge
DCU	DMA Controller Unit
DFS	Dynamic Frequency Selection
DIFS	Distributed Interframe Space
DMA	Direct Memory Access
dQH	Device Queue Head
DQPSK	Differential Quadrature Phase Shift Keying
DSM	Distribution System Medium
DSP	Digital Signal Processor
DSRC	Dedicated Short Range Communications
dTD	Linked List Transfer Descriptors
DTIM	Delivery Traffic Indication Message
DVSC	Digital Voltage Scaling Control
EAP	Extensible Authentication Protocol

Table 56. Acronyms and abbreviations...continued

Acronym	Definition
EBRAM	Extended Block Random Access Memory
ED	Energy Detect
EDCA	Enhanced Distributed Channel Access
EEPROM	Electrically Erasable Programmable Read Only Memory
EIFS	Extended Interframe Space
EMC	Electromagnetic Compatibility
ERP-OFDM	Extended Rate PHY-Orthogonal Frequency Division Multiplexing
ETSI	European Telecommunications Standards Institute
eWLP	Embedded Wafer Level Package
FAE	Field Application Engineer
FCC	Federal Communications Commission
FIFO	First In First Out
FIPS	Federal Information Processing Standards
FIQ	Fast Interrupt Request
FW	Firmware
GATT	Generic Attribute Profile
GCMP	Galois/Counter Mode Protocol
GI	Guard Interval
GPIO	General Purpose Input/Output
GPL	General Public License
GPU	General Purpose Input/Output Unit
HID	Human Interface Device
HIU	Host Interface Unit
HOGP	HID Over GATT Profile
HSP	Hands-Free Profile
HT	High Throughput
HW	Hardware
I/Q	Inphase/Quadrature
IB	InBand
IBSS	Independent Basic Service Set
ICE	In-Circuit Emulator (or Emulation)
ICR	Interrupt Cause Register
ICU	Interrupt Controller Unit
ICV	Integrity Check Value
IE	Information Element
IEEE	Institute of Electrical and Electronics Engineers

Table 56. Acronyms and abbreviations...continued

Acronym	Definition
IEMR	Interrupt Event Mask Register
I/F	Interface
IFS	Interframe Space
IMR	Interrupt Mask Register
IPG	Inter-Packet Gap
IPsec	Internet Protocol Security
IR	Infrared
IRQ	Interrupt Request
ISA	Instruction Set Architecture
ISDN	Integrated Services Digital Network
ISM	Industrial, Scientific, and Medical
ISMR	Interrupt Status Mask Register
ISR	Interrupt Status Register
JEDEC	Joint Electronic Device Engineering Council
JTAG	Joint Test Action Group
LDPC	Low Density Parity Check
LE	Low Energy
LED	Light Emitting Diode
LME	Layer Management Entity
LNA	Low Noise Amplifier
LPM	Low Power Management
LQFN	Low Quad Flat Non-leaded
LSb	Least Significant bit
LSB	Least Significant Byte
LSP	Low-Speed Peripheral
LTE	Long Term Evolution
MAC	Media/Medium Access Controller
MC	Memory Controller
MCS	Modulation and Coding Scheme
MCU	MAC Control Unit
MDI	Modem Data Interface
MIB	Management Information Base
MIC	Message Integrity Code
MII	Media Independent Interface
MIMO	Multiple Input Multiple Output
MIPS	Million Instructions Per Second

Table 56. Acronyms and abbreviations...continued

Acronym	Definition
MLME	MAC Sublayer Management Entity
MMI	Modem Management Interface
MMPDU	MAC Management Protocol Data Unit
MMU	Memory Management Unit
MPDU	MAC Protocol Data Unit
MSb	Most Significant bit
MSB	Most Significant Byte
MSDU	MAC Service Data Unit
MU-MIMO	Multi-User MIMO
MU-PPDU	Multi-User PPDU
MWS	Mobile Wireless System Multimedia Wireless System
NAV	Network Allocation Vector
NDP	Null Data Packet
NL	No Load
NPTR	Next Descriptor Pointer
OCB	Outside the Context of a BSS
OFDM	Orthogonal Frequency Division Multiplexing
OID	Object Identifier
OOB	Out of Band
OTP	One Time Programmable
P2P	Peer-to-Peer
PA	Power Amplifier
PAD	Packet Assembler/Disassembler
PBU	Peripheral Bus Unit
PC	Point Coordinator
PCB	Printed Circuit Board
PCF	Point Coordination Function
PCI	Peripheral Component Interconnect
PCIe	PCI Express
PCM	Pulse Code Modulation
PDn	Power Down
PDU	Protocol Data Unit
PEAP	Protected EAP
PHY	Physical Layer
PIFS	Priority Interframe Space

Table 56. Acronyms and abbreviations...continued

Acronym	Definition
PLL	Phase-Locked Loop
PLME	Physical Layer Management Entity
PMU	Power Management Unit
POST	Power-On Self Test
PPDU	PHY Protocol Data Unit
PPK	Per-Packet Key
PPM	Pulse Position Modulation
PSK	Pre-Shared Keys
PTA	Packet Traffic Arbitration
PWK	Pairwise Key
QAM	Quadrature Amplitude Modulation
QFN	Quad Flat Non-leaded Package
QoS	Quality of Service
RA	Receiver Address
RBDS	Radio Broadcast Data System
RDS	Radio Data System
RF	Radio Frequency
RFID	Radio Frequency Identification
RIFS	Reduced Interframe Space
RISC	Reduced Instruction Set Computer
ROM	Read Only Memory
RSSI	Receiver Signal Strength Indication
RTS	Request to Send
RTU	General Purpose Timer Unit
RU	Resource Unit
SA	Source Address
SAP	Service Access Point
SCLK	Serial Interface Clock
SDA	Serial Interface Data
SE	Secure Element
SFD	Start of Frame Delimiter
SIFS	Short Interframe Space
SISO	Single Input Single Output
SIU	Serial Interface Unit (UART)
SJU	System/Software JTAG Controller Unit
SM	Switch Module

Table 56. Acronyms and abbreviations...continued

Acronym	Definition
SMI	Serial Management Interface
SNR	Signal-to-Noise Ratio
SO	Serial Out
SoC	System-on-Chip
SPDT	Single Pole Double Throw
SPI	Serial Peripheral Interface
SQU	Internal SRAM Unit
SRWB	Serial Interface Read Write
SS	Service Set
SSID	Service Set Identifier
STA	Station
STBC	Space-Time Block Code
SWD	Serial Wire Debug
SWP	Single Wire Protocol
TA	Transmitter Address
TBG	Time Base Generator
TBTT	Target Beacon Transmission Time
TCM	Tightly Coupled Memory
TCP/IP	Transmission Control Protocol/Internet Protocol
TCQ	Traffic Category Queue
TIM	Traffic Indication Map
TKIP	Temporal Key Integrity Protocol
TPC	Transmit Power Control
TQFP	Thin Quad Flat Pack
TRPC	Transmit Rate-based Power Control
TSC	TKIP Sequence Counter
TSF	Timing Synchronization Function
TWT	Target Wait Time
UART	Universal Asynchronous Receiver/Transmitter
UBM	Under Bump Metal
UDP	User Datagram Protocol
UNII	Unlicensed National Information Infrastructure
VCO	Voltage Controlled Oscillator
VIF	Voice Interface
VHT	Very High Throughput
WAP	Wireless Application Protocol

Table 56. Acronyms and abbreviations...continued

Acronym	Definition
WAVE	Wireless Access in Vehicular Environments
WCI-2	Wireless Coexistence Interface 2
WEP	Wired Equivalent Privacy
WI	Wired Interface
Wi-Fi	Hardware implementation of IEEE 802.11 for wireless connectivity
WLAN	Wireless Local Area Network
WMM	Wi-Fi Multimedia
WPA	Wi-Fi Protected Access
WPA2	Wi-Fi Protected Access 2
WPA2-PSK	Wi-Fi Protected Access 2-Pre-Shared Key
WPA-PSK	Wi-Fi Protect Access-Pre-Shared Key
XFQFN	Extra-Fine Quad Flat Non-leaded
XOSC	Crystal Oscillator

12 Revision history

Table 57. Revision history

Document ID	Release date	Data sheet status	Change notice	Supersedes
88W8977_SDS v3.0	20210513	Product short data sheet	—	88W8977 v2.0
Modifications	<ul style="list-style-type: none"> Updated Bluetooth 5 to Bluetooth 5.2 			
88W8977_SDS v2.0	20201214	Product short data sheet	202007031F01 202007032F01	88W8977 v1.0
Modifications	<ul style="list-style-type: none"> Replaced 88W8977 document ID with 88W8977_SDS. Section 10.3 "Package marking": updated. Section 2 "Ordering information": moved to the beginning of the document (no other changes). 			
88W8977 v1.0	20200713	Product short data sheet	-	-

13 Legal information

13.1 Data sheet status

Document status ^{[1][2]}	Product status ^[3]	Definition
Objective [short] data sheet	Development	This document contains data from the objective specification for product development.
Preliminary [short] data sheet	Qualification	This document contains data from the preliminary specification.
Product [short] data sheet	Production	This document contains the product specification.

[1] Please consult the most recently issued document before initiating or completing a design.

[2] The term 'short data sheet' is explained in section "Definitions".

[3] The product status of device(s) described in this document may have changed since this document was published and may differ in case of multiple devices. The latest product status information is available on the Internet at URL <http://www.nxp.com>.

13.2 Definitions

Draft — A draft status on a document indicates that the content is still under internal review and subject to formal approval, which may result in modifications or additions. NXP Semiconductors does not give any representations or warranties as to the accuracy or completeness of information included in a draft version of a document and shall have no liability for the consequences of use of such information.

Short data sheet — A short data sheet is an extract from a full data sheet with the same product type number(s) and title. A short data sheet is intended for quick reference only and should not be relied upon to contain detailed and full information. For detailed and full information see the relevant full data sheet, which is available on request via the local NXP Semiconductors sales office. In case of any inconsistency or conflict with the short data sheet, the full data sheet shall prevail.

Product specification — The information and data provided in a Product data sheet shall define the specification of the product as agreed between NXP Semiconductors and its customer, unless NXP Semiconductors and customer have explicitly agreed otherwise in writing. In no event however, shall an agreement be valid in which the NXP Semiconductors product is deemed to offer functions and qualities beyond those described in the Product data sheet.

13.3 Disclaimers

Limited warranty and liability — Information in this document is believed to be accurate and reliable. However, NXP Semiconductors does not give any representations or warranties, expressed or implied, as to the accuracy or completeness of such information and shall have no liability for the consequences of use of such information. NXP Semiconductors takes no responsibility for the content in this document if provided by an information source outside of NXP Semiconductors. In no event shall NXP Semiconductors be liable for any indirect, incidental, punitive, special or consequential damages (including - without limitation - lost profits, lost savings, business interruption, costs related to the removal or replacement of any products or rework charges) whether or not such damages are based on tort (including negligence), warranty, breach of contract or any other legal theory. Notwithstanding any damages that customer might incur for any reason whatsoever, NXP Semiconductors' aggregate and cumulative liability towards customer for the products described herein shall be limited in accordance with the Terms and conditions of commercial sale of NXP Semiconductors.

Right to make changes — NXP Semiconductors reserves the right to make changes to information published in this document, including without limitation specifications and product descriptions, at any time and without

notice. This document supersedes and replaces all information supplied prior to the publication hereof.

Suitability for use — NXP Semiconductors products are not designed, authorized or warranted to be suitable for use in life support, life-critical or safety-critical systems or equipment, nor in applications where failure or malfunction of an NXP Semiconductors product can reasonably be expected to result in personal injury, death or severe property or environmental damage. NXP Semiconductors and its suppliers accept no liability for inclusion and/or use of NXP Semiconductors products in such equipment or applications and therefore such inclusion and/or use is at the customer's own risk.

Applications — Applications that are described herein for any of these products are for illustrative purposes only. NXP Semiconductors makes no representation or warranty that such applications will be suitable for the specified use without further testing or modification. Customers are responsible for the design and operation of their applications and products using NXP Semiconductors products, and NXP Semiconductors accepts no liability for any assistance with applications or customer product design. It is customer's sole responsibility to determine whether the NXP Semiconductors product is suitable and fit for the customer's applications and products planned, as well as for the planned application and use of customer's third party customer(s). Customers should provide appropriate design and operating safeguards to minimize the risks associated with their applications and products. NXP Semiconductors does not accept any liability related to any default, damage, costs or problem which is based on any weakness or default in the customer's applications or products, or the application or use by customer's third party customer(s). Customer is responsible for doing all necessary testing for the customer's applications and products using NXP Semiconductors products in order to avoid a default of the applications and the products or of the application or use by customer's third party customer(s). NXP does not accept any liability in this respect.

Limiting values — Stress above one or more limiting values (as defined in the Absolute Maximum Ratings System of IEC 60134) will cause permanent damage to the device. Limiting values are stress ratings only and (proper) operation of the device at these or any other conditions above those given in the Recommended operating conditions section (if present) or the Characteristics sections of this document is not warranted. Constant or repeated exposure to limiting values will permanently and irreversibly affect the quality and reliability of the device.

Terms and conditions of commercial sale — NXP Semiconductors products are sold subject to the general terms and conditions of commercial sale, as published at <http://www.nxp.com/profile/terms>, unless otherwise agreed in a valid written individual agreement. In case an individual agreement is concluded only the terms and conditions of the respective agreement shall apply. NXP Semiconductors hereby expressly objects to applying the customer's general terms and conditions with regard to the purchase of NXP Semiconductors products by customer.

No offer to sell or license — Nothing in this document may be interpreted or construed as an offer to sell products that is open for acceptance or the grant, conveyance or implication of any license under any copyrights, patents or other industrial or intellectual property rights.

Quick reference data — The Quick reference data is an extract of the product data given in the Limiting values and Characteristics sections of this document, and as such is not complete, exhaustive or legally binding.

Export control — This document as well as the item(s) described herein may be subject to export control regulations. Export might require a prior authorization from competent authorities.

Non-automotive qualified products — Unless this data sheet expressly states that this specific NXP Semiconductors product is automotive qualified, the product is not suitable for automotive use. It is neither qualified nor tested in accordance with automotive testing or application requirements. NXP Semiconductors accepts no liability for inclusion and/or use of non-automotive qualified products in automotive equipment or applications. In the event that customer uses the product for design-in and use in automotive applications to automotive specifications and standards, customer (a) shall use the product without NXP Semiconductors' warranty of the product for such automotive applications, use and specifications, and (b) whenever customer uses the product for automotive applications beyond NXP Semiconductors' specifications such use shall be solely at customer's own risk, and (c) customer fully indemnifies NXP Semiconductors for any liability, damages or failed product claims resulting from customer design and use of the product for automotive applications beyond NXP Semiconductors' standard warranty and NXP Semiconductors' product specifications.

Translations — A non-English (translated) version of a document is for reference only. The English version shall prevail in case of any discrepancy between the translated and English versions.

Security — Customer understands that all NXP products may be subject to unidentified or documented vulnerabilities. Customer is responsible for the design and operation of its applications and products throughout their lifecycles to reduce the effect of these vulnerabilities on customer's applications and products. Customer's responsibility also extends to other open and/or proprietary technologies supported by NXP products for use in customer's applications. NXP accepts no liability for any vulnerability. Customer should regularly check security updates from NXP and follow up appropriately. Customer shall select products with security features that best meet rules, regulations, and standards of the intended application and make the ultimate design decisions regarding its products and is solely responsible for compliance with all legal, regulatory, and security related requirements concerning its products, regardless of any information or support that may be provided by NXP. NXP has a Product Security Incident Response Team (PSIRT) (reachable at PSIRT@nxp.com) that manages the investigation, reporting, and solution release to security vulnerabilities of NXP products.

13.4 Trademarks

Notice: All referenced brands, product names, service names and trademarks are the property of their respective owners.

NXP — wordmark and logo are trademarks of NXP B.V.

Tables

Tab. 1.	Part Order Codes	5	Tab. 33.	Bluetooth/Bluetooth LE transmitter performance	47
Tab. 2.	Pad locations—74-bump eWLP	13	Tab. 34.	Current consumption	49
Tab. 3.	Pin types	17	Tab. 35.	DC electricals—1.8V operation (VIO_SD)	51
Tab. 4.	General purpose I/O/LED interface	18	Tab. 36.	DC electricals—3.3V operation (VIO_SD)	51
Tab. 5.	RF front-end control interface	20	Tab. 37.	SDIO timing data—Default speed mode and high-speed modes (3.3V)	53
Tab. 6.	Wi-Fi/Bluetooth radio interface	20	Tab. 38.	SDIO timing data—SDR12, SDR25, SDR50 modes (up to 100 MHz) (1.8V)	54
Tab. 7.	Bluetooth external coexistence interface	21	Tab. 39.	SDIO timing data—DDR50 mode (50 MHz)	56
Tab. 8.	SDIO host interface	22	Tab. 40.	UART timing data	57
Tab. 9.	UART host interface (MFP)	22	Tab. 41.	PCM timing specification diagram for data signals—Master mode	58
Tab. 10.	LTE interface	23	Tab. 42.	PCM timing specification diagram for sync signal—Master mode	58
Tab. 11.	PCM interface pins (MFP)	23	Tab. 43.	PCM timing specification data—Master mode	58
Tab. 12.	Power management interface pins (MFP)	23	Tab. 44.	PCM timing specification diagram for data signals—Slave mode	59
Tab. 13.	Power supply and ground pins	24	Tab. 45.	PCM timing specification diagram for sync signal—Slave mode	59
Tab. 14.	Clock interface	24	Tab. 46.	PCM timing specification data—Slave mode	59
Tab. 15.	Power-down pin	25	Tab. 47.	CMOS mode	60
Tab. 16.	JTAG interface pins (MFP)	25	Tab. 48.	Low-Swing Mode	60
Tab. 17.	Configuration pins	26	Tab. 49.	Phase Noise—2.4 GHz operation	60
Tab. 18.	Firmware boot options	26	Tab. 50.	Phase noise—Dual-band operation	60
Tab. 19.	Absolute Maximum Ratings	33	Tab. 51.	Crystal specifications	61
Tab. 20.	Recommended Operating Conditions	34	Tab. 52.	External sleep clock timing	61
Tab. 21.	DC electricals—1.8V operation (VIO)	35	Tab. 53.	JTAG timing data	62
Tab. 22.	DC electricals—2.5V operation (VIO)	35	Tab. 54.	Thermal conditions of QFN package	63
Tab. 23.	DC electricals—3.3V operation (VIO)	35	Tab. 55.	Thermal conditions of eWLP package	64
Tab. 24.	LED mode data	36	Tab. 56.	Acronyms and abbreviations	68
Tab. 25.	DC electricals—1.8V operation (VIO_RF)	37	Tab. 57.	Revision history	75
Tab. 26.	DC electricals—3.3V operation (VIO_RF)	37			
Tab. 27.	2.4 GHz Wi-Fi receiver performance	39			
Tab. 28.	5 GHz Wi-Fi receiver performance	41			
Tab. 29.	2.4 GHz Wi-Fi transmitter performance	43			
Tab. 30.	5 GHz Wi-Fi transmitter performance	44			
Tab. 31.	Local oscillator	44			
Tab. 32.	Bluetooth/Bluetooth LE receiver performance	45			

Figures

Fig. 1.	88W8977 functional block diagram	2	Fig. 14.	SDIO protocol timing diagram—Default speed mode (3.3V)	52
Fig. 2.	88W8977 internal block diagram	4	Fig. 15.	SDIO protocol timing diagram—High-speed mode (3.3V)	52
Fig. 3.	Part numbering scheme	5	Fig. 16.	SDIO protocol timing diagram—SDR12, SDR25, SDR50 modes (up to 100 MHz) (1.8V)	54
Fig. 4.	88W8977 signal diagram	11	Fig. 17.	SDIO CMD timing diagram—DDR50 Mode (50 MHz)	55
Fig. 5.	Pin assignment for 68-pin package option (top view)	12	Fig. 18.	SDIO DAT[3:0] timing diagram—DDR50 mode (50 MHz)	55
Fig. 6.	Pad locations—74-bump WLCSP (Non-bump-side view, bumps down)	13	Fig. 19.	Figure Caption	57
Fig. 7.	Configuration—VCORE from PMIC	28	Fig. 20.	JTAG timing diagram	62
Fig. 8.	Configuration—VCORE from Internal LDO	29	Fig. 21.	68-pin QFN package mechanical drawing	65
Fig. 9.	Power-up sequence	30	Fig. 22.	74-bump package mechanical drawing	66
Fig. 10.	Recommended power-down sequence	31	Fig. 23.	68-pin QFN package marking and pin 1 location	67
Fig. 11.	Power-down using PMIC_EN host pin - PMIC and 88W8977 both in power-down mode	32			
Fig. 12.	Slew rate measurement diagram	36			
Fig. 13.	RF performance measurement points	38			

Fig. 24. 74-bump eWLP package marking and pin 1 location 67

Contents

1	Product overview	1	9	Electrical specifications	35
1.1	Applications	2	9.1	GPIO/LED interface specifications	35
1.2	Wi-Fi key features	2	9.1.1	VIO DC characteristics	35
1.3	Bluetooth key features	2	9.1.1.1	1.8V operation	35
1.4	Host interfaces	3	9.1.1.2	2.5V operation	35
1.5	Operating characteristics	3	9.1.1.3	3.3V operation	35
1.6	General features	3	9.1.2	LED mode	36
1.7	Internal block diagram	4	9.2	RF front-end control interface specifications	37
2	Ordering information	5	9.2.1	VIO_RF DC characteristics	37
3	Wi-Fi subsystem	6	9.2.1.1	1.8V operation	37
3.1	IEEE 802.11 standards	6	9.2.1.2	3.3V operation	37
3.2	Wi-Fi MAC	6	9.3	Wi-Fi radio specifications	38
3.3	Wi-Fi baseband	7	9.3.1	Wi-Fi radio performance measurement	38
3.4	Wi-Fi radio	7	9.3.2	2.4 GHz Wi-Fi receiver performance	39
3.5	Wi-Fi encryption	8	9.3.3	5 GHz Wi-Fi receiver performance	41
3.6	Wi-Fi host interfaces	8	9.3.4	2.4 GHz Wi-Fi transmitter performance	43
4	Bluetooth subsystem	9	9.3.5	5 GHz Wi-Fi transmitter performance	44
4.1	Bluetooth	9	9.3.6	Local oscillator	44
4.2	Bluetooth Low Energy (LE)	9	9.4	Bluetooth radio specifications	45
4.3	Bluetooth host interfaces	10	9.4.1	Bluetooth/Bluetooth LE receiver performance	45
4.4	PCM interface	10	9.4.2	Bluetooth/Bluetooth LE transmitter performance	47
5	Pin information	11	9.5	Current consumption	49
5.1	Signal diagram	11	9.6	Coexistence specifications	50
5.2	Pin assignment - 68-pin QFN package option	12	9.7	SDIO host interface specifications	51
5.3	Pad locations - 74-bump eWLP	13	9.7.1	VIO_SD DC characteristics	51
5.4	Pin description	17	9.7.1.1	1.8V operation	51
5.4.1	Pin types	17	9.7.1.2	3.3V operation	51
5.4.2	Pin states	17	9.7.2	Default speed mode and high-speed mode	52
5.4.3	General Purpose I/O (GPIO)/LED interface	18	9.7.3	SDR12, SDR25, SDR50 modes (up to 100 MHz) (1.8V)	54
5.4.4	RF front-end control interface	20	9.7.4	DDR50 Mode (50 MHz) (1.8V)	55
5.4.5	Wi-Fi/Bluetooth radio interface	20	9.8	UART interface specifications	57
5.4.6	Bluetooth external coexistence interface	21	9.9	PCM interface specifications	58
5.4.7	SDIO host interface	22	9.10	Clock specifications	60
5.4.8	UART host interface	22	9.10.1	Single-ended clock input modes	60
5.4.9	LTE external coexistence interface	23	9.10.1.1	2.4 GHz mode	60
5.4.10	PCM interface	23	9.10.1.2	2.4 GHz and 5 GHz dual-band mode	60
5.4.11	Power management interface	23	9.10.2	Crystal	61
5.4.12	Power supply and ground pins	24	9.10.3	Sleep clock	61
5.4.13	Clock interface	24	9.11	JTAG interface specifications	62
5.4.14	Power-down pin	25	10	Package information	63
5.4.15	JTAG interface	25	10.1	Package thermal conditions	63
5.5	Configuration pins	26	10.1.1	QFN package thermal conditions	63
6	Power information	27	10.1.2	eWLP package thermal conditions	64
6.1	Leakage optimization	27	10.2	Package mechanical data	65
6.2	Power-up	27	10.2.1	68-pin QFN package mechanical drawing	65
6.2.1	Configuration—PMIC supplies VCORE	28	10.2.2	74-bump eWLP package mechanical drawing	66
6.2.2	Configuration—Internal LDO supplies VCORE	29	10.3	Package marking	67
6.2.3	Power-up sequence	30	10.3.1	68-pin QFN package marking	67
6.3	Power-down	31	10.3.2	74-bump eWLP package marking	67
6.3.1	Recommended power-down sequence	31	11	Acronyms and abbreviations	68
6.3.2	Power-down using PMIC_EN host pin	32	12	Revision history	75
6.4	Deep sleep	32	13	Legal information	76
7	Absolute maximum ratings	33			
8	Recommended operating conditions	34			

Please be aware that important notices concerning this document and the product(s) described herein, have been included in section 'Legal information'.

© NXP B.V. 2021.

All rights reserved.

For more information, please visit: <http://www.nxp.com>

For sales office addresses, please send an email to: salesaddresses@nxp.com

Date of release: 13 May 2021

Document identifier: 88W8977_SDS

Mouser Electronics

Authorized Distributor

Click to View Pricing, Inventory, Delivery & Lifecycle Information:

NXP:

[88W8977-A1-NMV2E005-P123](#) [88W8977-A1-EAD2E005-T](#)