

# NAND Flash Memory

(AX20NV2G8, AX20NV2G6)

## Features

- Interface
  - Open NAND Flash Interface (ONFI 1.0) compliant
  - x8, x16
- Technology
  - Single-level cell (SLC)
  - 3xnm NAND Process
- Operating Voltage Range
  - V<sub>CC</sub>: 2.70V – 3.60V
- Operating Temperature Range
  - Industrial: -40°C to 85°C
- Packages
  - 48-pin TSOP (12.0mm x 20mm)
  - 63-ball FBGA (9mm x 11mm)
- Device Signature
  - Manufacturer's ID
  - Device ID
  - Device Parameters
  - Unique ID
- One Time Programmable Area (OTP)
  - One Block (128K + 4K bytes)
- Quality and Reliability
  - Recommended Error Correction Code: 4-bit / 528 bytes of data
  - Data retention: 10 years
  - Endurance (P/E cycles): 100K (Typ.)
- Block zero (block address 00h) is a valid block when shipped from factory and will remain valid for at least 1K P/E cycles with ECC
- Memory Array Organization
  - x8
    - Page size: 2176 bytes (2048 + 128 bytes)
  - x16
    - Page size: 1088 words (1024 + 64 words)
  - Block size: 64 pages (128K + 8K bytes)
  - Device size: 2048 blocks (2 Planes)
- Data Protection
  - WP# signal: write protect entire device
- Device Status
  - Ready/Busy# (R/B#) signal: hardware method for detecting internal operation completion status
- Advanced Command Set
  - Program page cache mode
  - Read page cache mode
  - Page data move (copy back):
  - Internal data move
  - Multi-plane Commands

## Performance

Device Operation	Values	Units
Read page	30.0 (Maximum)	µs
Program Page	300.0 (Typical)	µs
Block Erase	3.5 (Typical)	ms
Standby	10.0 (Typical)	µA
Read page	15.0 (Typical)	mA

## Table of Contents

Features.....	1
Performance .....	1
Table of Contents.....	2
General Description.....	3
Ordering Options .....	4
Valid Combinations — Standard.....	4
Signal Description and Assignment .....	5
Package Options .....	6
48-Pin TSOP (Top View) .....	6
63-Ball FBGA (Balls Down, Top View) .....	7
Architecture.....	8
Status Register .....	11
Bus Interface .....	17
Standby.....	17
Busy.....	17
Device Protection (Write Protect WP#) .....	17
Command Input.....	18
Address Input.....	18
Data Input.....	19
Data Output.....	20
Command Set.....	21
Device Initialization .....	53
Device Power-Down .....	55
Electrical Specifications.....	56
Error Management .....	59
ECC Management.....	60
Product Use Limitations.....	61
Limited Warranty.....	61
Revision History .....	62

## General Description

Axia Memory Technology's AX20NV2Gx is a 3.0V 2Gbit NAND Flash organized as 2176 bytes × 64 pages × 2048 blocks. All read and program operations are performed using a 2176-byte register; allowing data to be transferred to and from the memory array in 2176-bytes increments. The erase operation is implemented in a single block unit (2176 bytes × 64 pages).

Axia's NAND Flash devices communicate through an asynchronous ONFI 1.0 compatible interface for high-performance I/O operations. It is a multiplexed 8-bit/16-bit bus (I/Ox) that transfers commands, address, and data. There are five control signals used to implement the asynchronous data interface: CE#, CLE, ALE, WE#, and RE#. Additional signals control hardware write protection (WP#) and monitor device status (R/B#). This hardware interface creates a low pin-count device with a standard pinout that remains the same in Axia's NAND device family, enabling future upgrades to higher densities with no board redesign.

Additionally, Axia's NAND Flash devices support a copy back function which optimizes management of defective blocks. When a page program operation fails, the data already loaded in the page buffer can be directly programmed to another page inside the same array section without the time-consuming serial data insertion phase.

Also present in Axia's NAND Flash devices is a cache read feature that increases the read throughput. During cache reading, the device loads the new data in a cache register while the previous data is transferred to the I/Os.

And finally, Axia's NAND Flash devices provide special features listed below in Table 1:

*Table 1: Special Features*

#	Feature Description	Details
1	One-Time Programmable Area	Size: 1 block (128K + 8K bytes)
2	Unique Identifier	Size: 16 bytes

## Ordering Options

The ordering part numbers are formed by a valid combination of the following options:

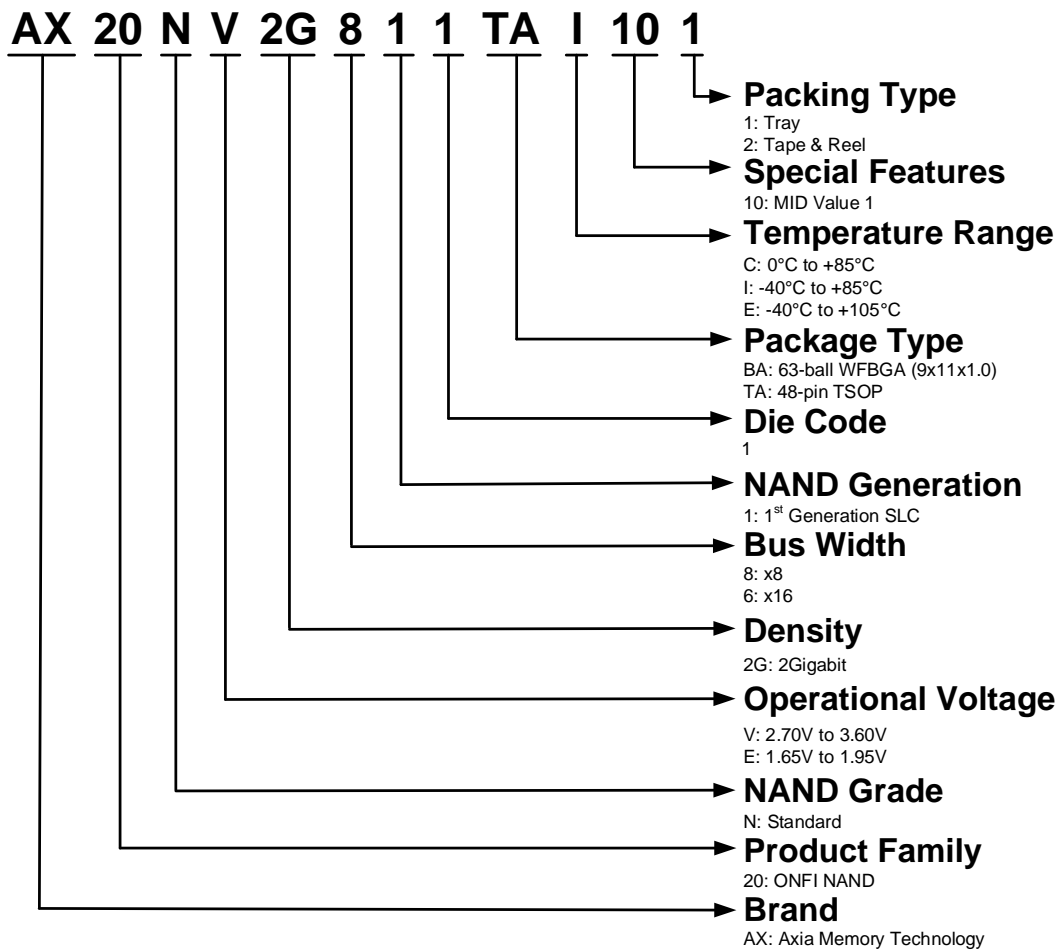

### Valid Combinations — Standard

Valid Combinations list includes device configurations currently available. Contact your local sales office to confirm availability of specific valid combinations and to check on newly released combinations.

Table 2: Valid Combinations List

Valid Combinations								
Base Part Number	Bus Width	Generation	Die Code	Package type	Temperature Range	Special Features	Packing Type	Part Number
AX20NV2G	x8	1	1	BA, TA	I	10	1, 2	AX20NV2G811BAI101
								AX20NV2G811TAI101
								AX20NV2G811BAI102

## Signal Description and Assignment

Figure 1: Device Pinout

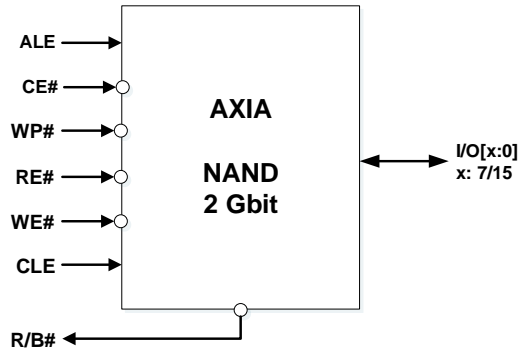
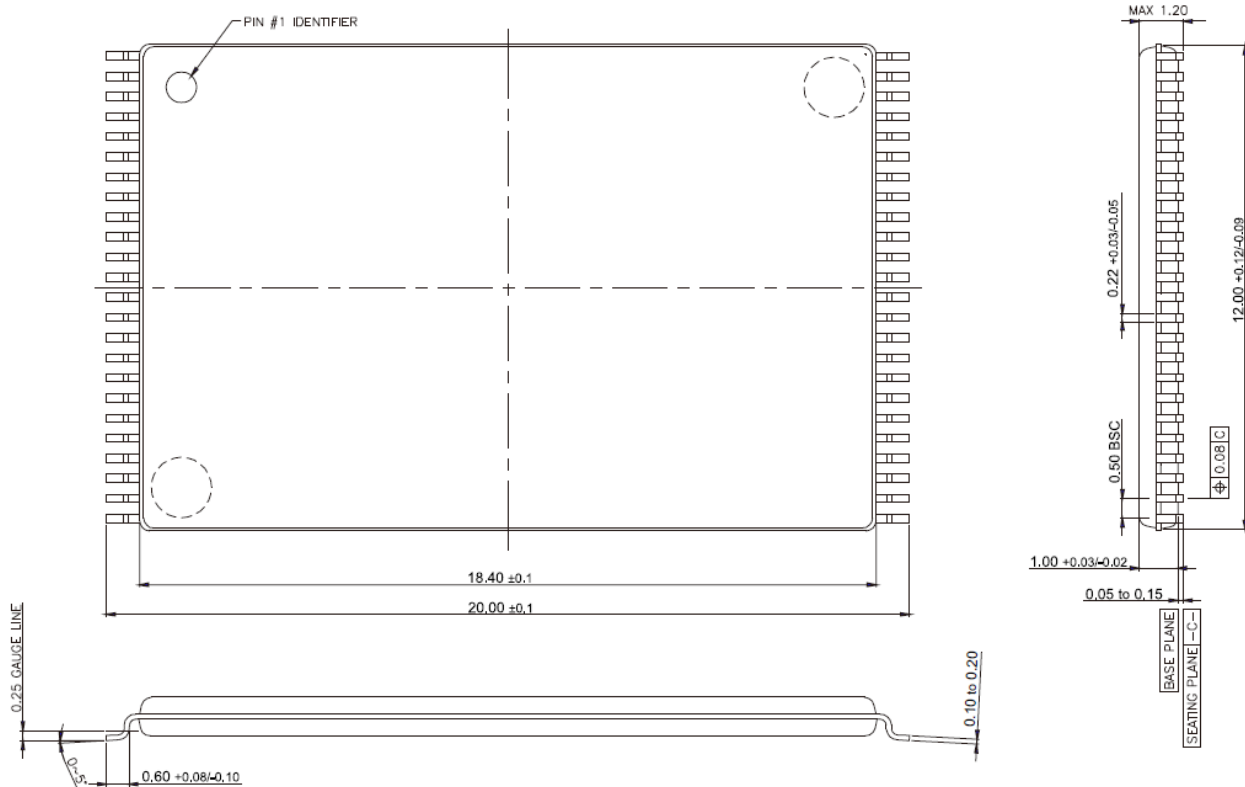
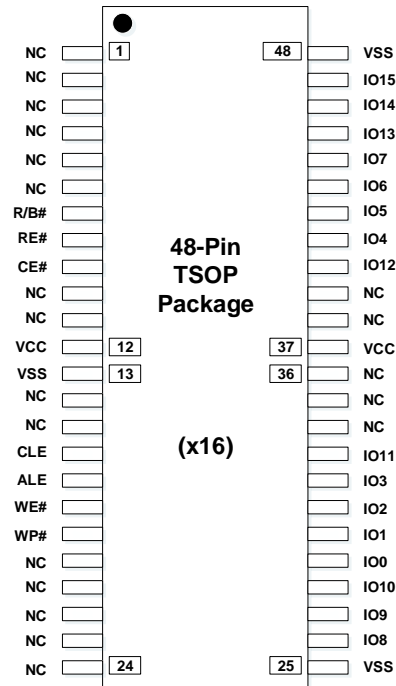
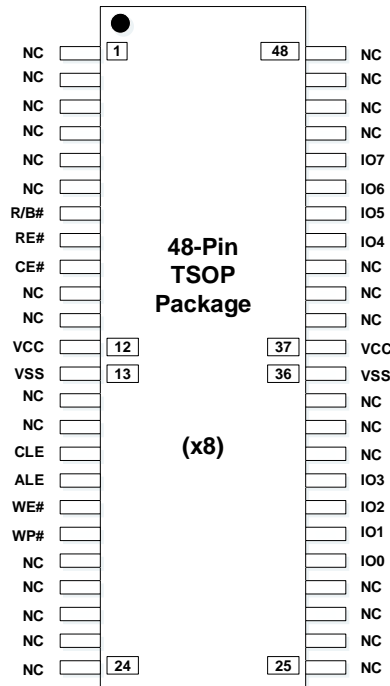

Table 3: Signal Description

Signal	Type	Description
<b>CE#</b>	Input	<b>Chip enable:</b> Enables or disables the NAND Flash.
<b>CLE</b>	Input	<b>Command latch enable:</b> Loads a command from x8 - I/O[7:0], x16 - I/O[15:0] into the command register.
<b>ALE</b>	Input	<b>Address latch enable:</b> Loads an address from x8 - I/O[7:0], x16 - I/O[15:0] into the address register.
<b>WE#</b>	Input	<b>Write enable:</b> Transfers commands, addresses, and serial data from the host system to the NAND Flash.
<b>RE#</b>	Input	<b>Read enable:</b> Transfers serial data from the NAND Flash to the host system.
<b>WP#</b>	Input	<b>Write protect:</b> Enables or disables array PROGRAM and ERASE operations.
<b>R/B#</b>	Output	<b>Ready/Busy:</b> An open-drain, active-low output that requires an external pull-up resistor. This signal indicates NAND Flash activity.
<b>I/O [7:0] - x8 I/O [15:0] - x16</b>	Input / Output	<b>Data inputs/outputs:</b> The bidirectional I/Os transfer address, data, and command information.
<b>V<sub>cc</sub></b>	Supply	<b>V<sub>cc</sub>:</b> Core and I/O power supply.
<b>V<sub>ss</sub></b>	Supply	<b>V<sub>ss</sub>:</b> Core and I/O ground supply.
<b>NC</b>		<b>No connect:</b> NCs are not internally connected. They can be driven (V <sub>CC</sub> / V <sub>SS</sub> ) or left unconnected.
<b>DNU</b>		<b>Do not use:</b> DNUs must be left unconnected.

# Package Options

## 48-Pin TSOP (Top View)



63-Ball FBGA (Balls Down, Top View)

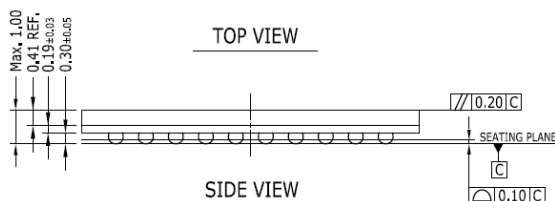
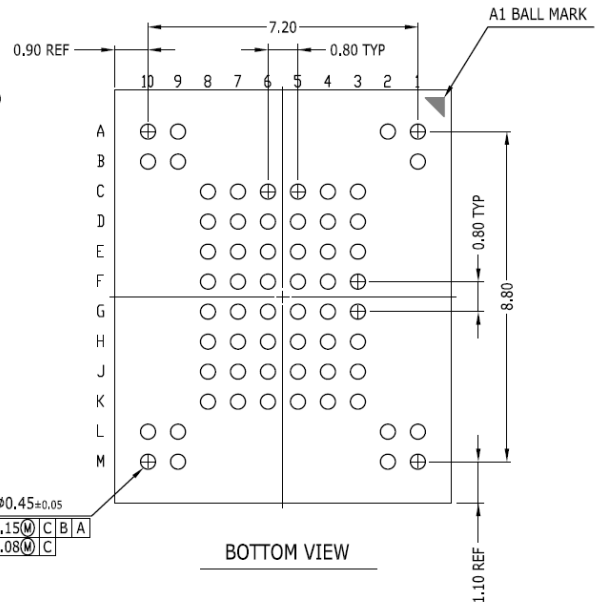
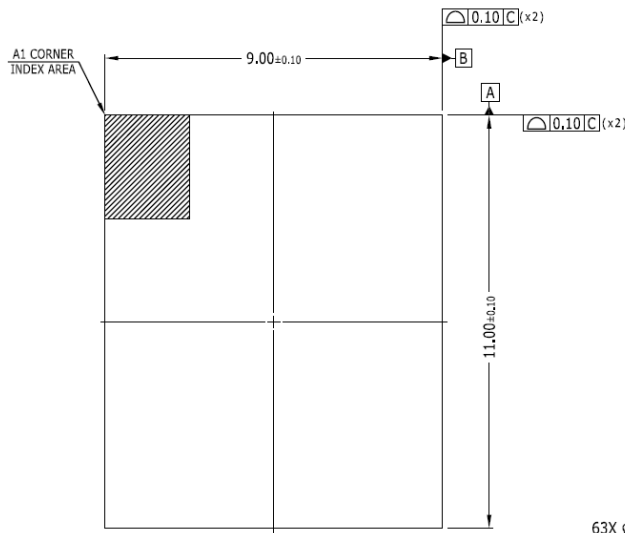
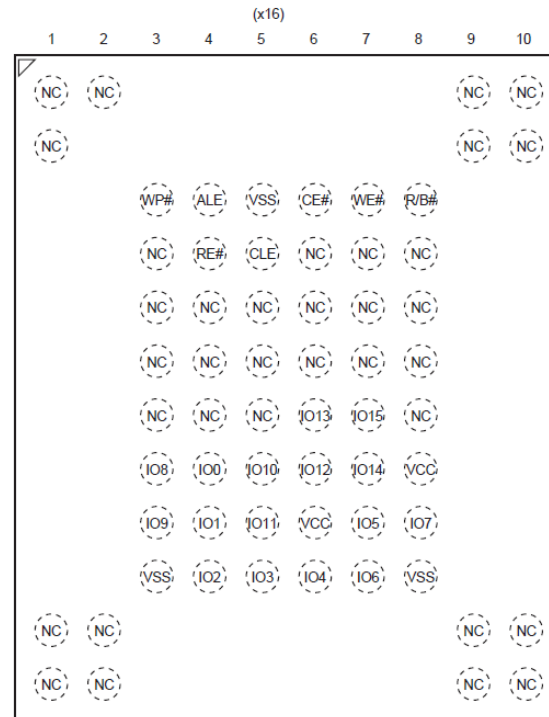
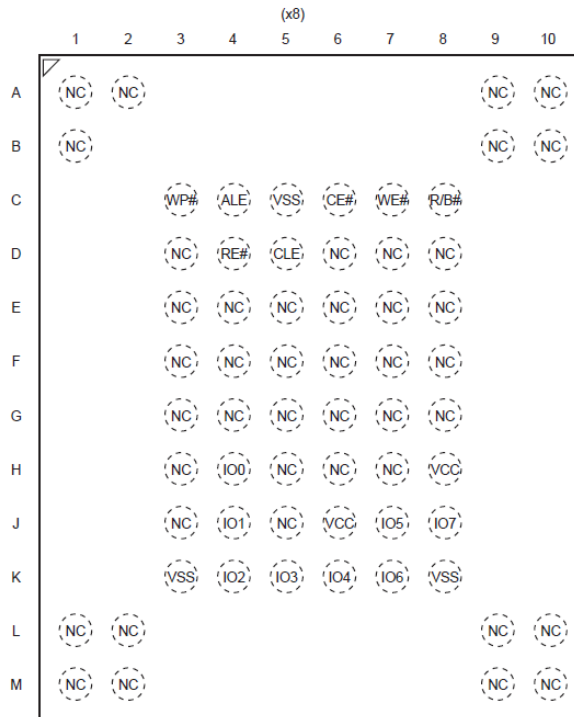

## Architecture

Axia's NAND Flash devices use ONFI 1.0 compatible interface for all operations. Data, commands, and addresses are multiplexed onto the I/O pins. The commands received at the I/Os are latched by a command register and are used to determine the operations the device must perform. The addresses are latched into an address register and sent either to a row decoder to select a row address, or to a column decoder to select a column address. Data is transferred to or from the NAND Flash memory array either in a byte format (x8) or in a word format (x16) through a page buffer which is a combination of a data register and a cache register. During normal page operations, the data and cache registers act as a single register. During cache operations, the data and cache registers operate independently to increase data throughput. The NAND Flash memory array is programmed and read using page-based operations and is erased using block-based operations. The status register reports the status of all operations.

Figure 2: Functional Block Diagram

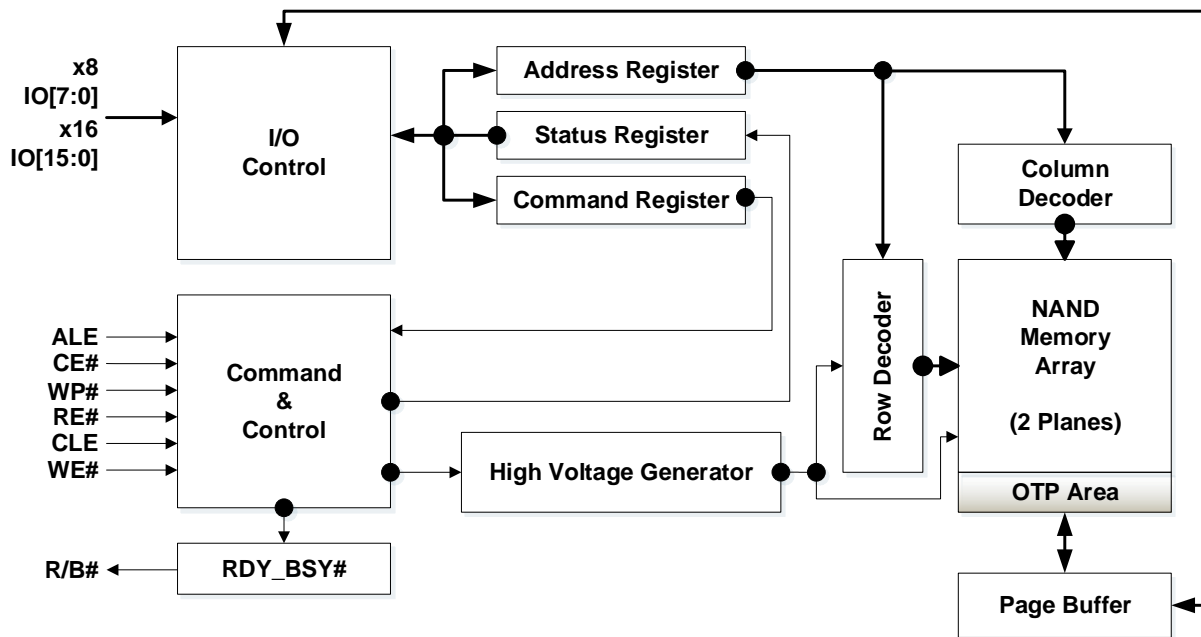



**Memory Array Architecture & Addressing**

Figure 3: Memory Array Architecture

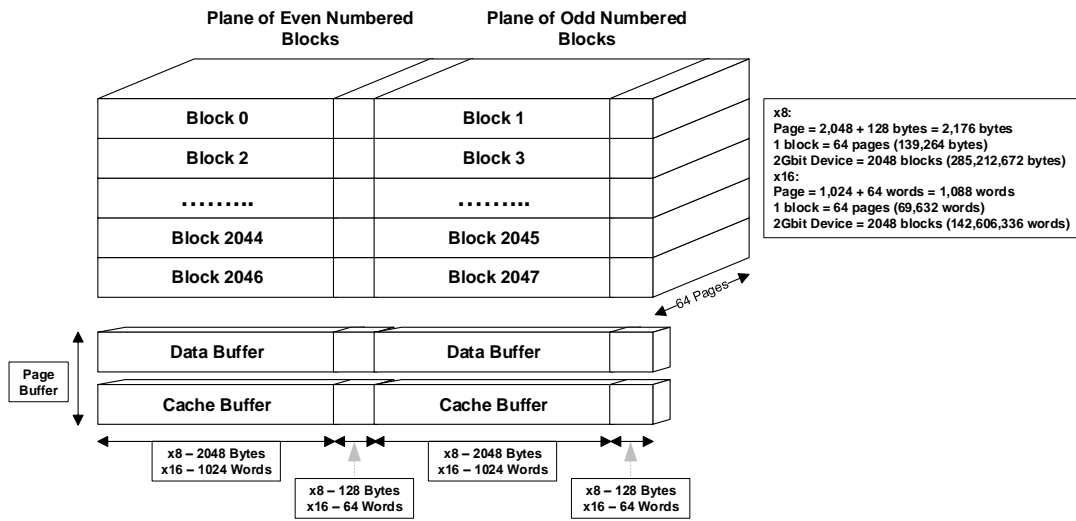

Table 4: Array Addressing Sequence – x8, x16

x8:									
Cycle	IO[7]	IO[6]	IO[5]	IO[4]	IO[3]	IO[2]	IO[1]	IO[0]	
First	BYTA7	BYTA6	BYTA5	BYTA4	BYTA3	BYTA2	BYTA1	BYTA0	
Second	Logic '0'	Logic '0'	Logic '0'	Logic '0'	BYTA11	BYTA10	BYTA9	BYTA8	
Third	BA7	BA6 / PLA	PA5	PA4	PA3	PA2	PA1	PA0	
Fourth	BA15	BA14	BA13	BA12	BA11	BA10	BA9	BA8	
Fifth	Logic '0'	Logic '0'	Logic '0'	Logic '0'	Logic '0'	Logic '0'	Logic '0'	Logic '0'	BA16
x16:									
Cycle	IO[15:8]	IO[7]	IO[6]	IO[5]	IO[4]	IO[3]	IO[2]	IO[1]	IO[0]
First	Logic '0'	WRDA7	WRDA6	WRDA5	WRDA4	WRDA3	WRDA2	WRDA1	WRDA0
Second	Logic '0'	Logic '0'	Logic '0'	Logic '0'	Logic '0'	Logic '0'	WRDA10	WRDA9	WRDA8
Third	Logic '0'	BA7	BA6 / PLA	PA5	PA4	PA3	PA2	PA1	PA0
Fourth	Logic '0'	BA15	BA14	BA13	BA12	BA11	BA10	BA9	BA8
Fifth	Logic '0'	Logic '0'	Logic '0'	Logic '0'	Logic '0'	Logic '0'	Logic '0'	Logic '0'	BA16

## Notes:

1. BYTAx: Byte based Column address, WRDAx: Word based Column address, PAX: Page address, BAx: Block address, PLA: Plane address
2. Block address concatenated with page address = actual page address
3. I/O[15:8] are not used during the addressing sequence and must be driven to Logic '0' (Low)
4. 1<sup>st</sup> and 2<sup>nd</sup> address cycles form the column Address, whereas 3<sup>rd</sup>, 4<sup>th</sup> and 5<sup>th</sup> address cycles form the row address



Table 5: Block Addressing

Block #	Row Address Range	Plane Number
Block 0	000000h ~ 00003Fh	0
Block 1	000040h ~ 00007Fh	1
Block 2	000080h ~ 0000BFh	0
.....		
Block 2045	01FF40h ~ 01FF7Fh	1
Block 2046	01FF80h ~ 01FFBFh	0
Block 2047	01FFC0h ~ 01FFFFh	1

## Status Register

Table 6: Status Register Definition

Status Register Bits	Name	Function	Default State	Description
SR[7]	WRPT	WP# based Device Protection	1	0 = Device is protected - WP# is Low 1 = Device Is not protected - WP# is High
SR[6]	RDY	Data Cache Register Ready Status Bit	1	0 = Data Cache is busy - not ready 1 = Data Cache is not busy - ready
SR[5]	ARDY	Memory Array Ready Status Bit	1	0 = Memory Array is busy - not ready 1 = Memory Array is not busy - ready
SR[4]	ECCS	Error Correction Code (ECC) Status	0	0 = On-die ECC Engine disabled / Error Count Normal 1 = Page Uncorrectable / Recommend Re-program
SR[3]	OTPS	One-Time Programmable (OTP) Area Protection Status	0	0 = OTP Area not protected 1 = OTP Area protected
SR[2]	RSVD	Reserved for Future Use	0	Reserved for Future Use
SR[1]	PS1	Program Status of the Previous Command	0	0 = Program was successful 1 = Program was not successful
SR[0]	PES	Program and Erase Status of the Current Command	0	0 = Program or Erase was successful 1 = Program or Erase was not successful

Notes:

- SR[7] – WRPT: If set to '1', the device is not write protected and can be programmed or erased. If cleared to '0', then the device is write protected and cannot be programmed or erased. This is always valid regardless of state of the R/B#.
- SR[6] - RDY: If set to '1', the device is ready for another command and all other status bits are valid. If cleared to '0', then the last command issued is not yet complete and all other status bits are not valid. When cache operations are in use, this bit indicates when the Cache buffer is ready to accept new data. R/B# follows RDY (SR[5] indicates if the last command was complete).
- SR[5] – ARDY: If set to '1', all array operations are complete. If cleared to zero, then there is a command being processed or an array operation in progress.
- SR[4] – ECCS: If the internal ECC is On, this bit indicates if the last read contained ECC errors. It is supported in two modes; selected using configuration register address 90h bit [4].
  - Mode 1: This mode indicates if a page has a high ECC error count and is recommended to rewrite the page. If set to '1', it is recommended to rewrite the entire page. If cleared to '0', it is in normal state (internal ECC enabled, error counts are in safe level), or internal ECC disabled.
  - Mode 2: This mode indicates if the page has more ECC errors than the internal engine can correct (UECC). If set to '1', it indicates that the ECC has failed and the page is uncorrectable. If cleared to '0', then it is in normal state (internal ECC enabled, safely working), or internal ECC disabled.
- SR[3] – OTPS: This bit indicates whether the OTP is in protected mode (locked down). This bit is set to '1' if the OTP is locked down and a program command is issued. It is cleared to '0' when either not in OTP mode, or power-up or when Reset command is issued.
- SR[1] – PS1: This bit is only valid for cache program operations and shows whether the previous operation was a success or a failure. This bit is not valid until after the second 15h command or the 10h command has been transferred in a Cache program sequence.
- SR[0] – PES: This bit is valid for program and erase operations and shows whether the operation was a success or a failure. During cache program operations, this bit is only valid when ARDY is set to '1'.



**Identification Definition (Address 00h)**

Table 7: Device Identification Definition (Address 00h)

Byte #		Options	Bit 7	Bit 6	Bit 5	Bit 4	Bit 3	Bit 2	Bit 1	Bit 0	Values	
0	Manufacturer's ID	MID	1	0	1	0	1	1	0	1	ADh	
1	Device ID	2Gbit, x8, 3.3V	1	1	1	1	0	0	0	1	DAh	
		2Gbit, x16, 3.3V	1	1	0	0	0	0	0	1	CAh	
2	Device Characteristics	Internal Device # 1							0	0	x8/x16 ↓ 90h/90h	
		Internal Device # 2							0	1		
		Internal Device # 4							1	0		
		Internal Device # 8							1	1		
		Cell Type - 2 LEVEL						0	0			
		Cell Type - 4 LEVEL						0	1			
		Cell Type - 8 LEVEL						1	0			
		Cell Type - 16 LEVEL						1	1			
		Simultaneous Programmed Pages - 1				0	0					
		Simultaneous Programmed Pages - 2				0	1					
		Simultaneous Programmed Pages - 4				1	0					
		Simultaneous Programmed Pages - 8				1	1					
		Interleaved Programming - Not Supported			0							
		Interleaved Programming - Supported			1							
		Cache Program - Not Supported		0								
		Cache Program - Supported		1								
3	Array Architecture	Page Size - 1KB							0	0	x8/x16 ↓ 95h/D5h	
		Page Size - 2KB							0	1		
		Page Size - 4KB							1	0		
		Page Size - 8KB							1	1		
		Spare Area Size - 8 bytes / 512 bytes							0			
		Spare Area Size - 16 bytes / 512 bytes							1			
		Block Size - 64KB				0	0					
		Block Size - 128KB				0	1					
		Block Size - 256KB				1	0					
		Block Size - 512KB				1	1					
	Interface Type	x8			0							
		x16			1							
	Access Time	45ns		0				0				
		25ns		1				0				



Byte #		Options	Bit 7	Bit 6	Bit 5	Bit 4	Bit 3	Bit 2	Bit 1	Bit 0	Values
		Reserved for Future Use	0				1				
		Reserved for Future Use	1				1				
4	ECC Level	1-bit per 512 Bytes							0	0	x8/x16 ↓ 46h/46h
		2-bits per 512 Bytes							0	1	
		4-bits per 512 Bytes							1	0	
		8-bits per 512 Bytes							1	1	
	Number of Planes	1 Plane					0	0			
		2 Planes					0	1			
		4 Planes					1	0			
		8 Planes					1	1			
	Size of Plane	Plane Size - 64Mb		0	0	0					
		Plane Size - 128Mb		0	0	1					
		Plane Size - 256Mb		0	1	0					
		Plane Size - 512Mb		0	1	1					
		Plane Size - 1Gb		1	0	0					
		Plane Size - 2Gb		1	0	1					
		Plane Size - 4Gb		1	1	0					
		Plane Size - 8Gb		1	1	1					
Reserved	Reserved for Future Use	0									

**Identification Definition (Address 20h)**

Table 8: Device Identification Definition (Address 20h)

Byte #	Option	Value
0	"O"	4Fh
1	"N"	4Eh
2	"F"	46h
3	"I"	49h

**Parameter Page Structure & Values**

Table 9: Parameter Page Structure &amp; Values

Byte #	O/M	Description	Values
<b>Revision Information &amp; Features Block</b>			
0 - 3	M	Signature "O" "N" "F" "I"	4Fh, 4Eh, 46h, 49h
4 - 5	M	Revision Number	02h, 00h
6 - 7	M	Features Supported Bit #      Value 0            1 = Supports 16-bit Data bus 1            1 = Supports multiple LUN operations 2            1 = Supports non-sequential page programming 3            1 = Supports interleaved operations 4            1 = Supports odd to even page Copyback 5 - 15      0 = Reserved	1Ch, 00h
8 - 9	M	Optional Commands Supported Bit #      Value 0            1 = Supports Page Cache Program 1            1 = Supports Read Cache 2            1 = Supports Get/Set features 3            1 = Supports Read Status Enhanced 4            1 = Supports Copyback 5            1 = Supports Read Unique ID 6 - 15      0 = Reserved	3Bh, 00h
10- 31		Reserved (0)	00h, 00h, 00h, 00h, 00h, 00h, 00h, 00h, 00h, 00h, 00h, 00h, 00h, 00h, 00h, 00h, 00h, 00h
<b>Manufacturer's Information Block</b>			
32 - 43	M	Manufacturer's ID (12 ASCII Characters)	53h, 4Bh, 20h, 48h, 59h, 4Eh, 49h, 58h, 20h, 20h, 20h, 20h
44 - 63	M	Device Model (20 ASCII Characters) H27U2G8F2DKA-BM H27U2G8F2DKA-BM	48h, 32h, 37h, 55h, 32h, 47h, 38h, 46h, 32h, 44h, 4Bh, 41h, 2Dh, 42h, 4Dh, 20h, 20h, 20h, 20h, 20h
64	M	JEDEC Manufacturer's ID	ADh
65 - 66	O	Date Code	00h, 00h
67 - 79		Reserved (0)	00h, 00h, 00h, 00h, 00h, 00h, 00h, 00h, 00h, 00h, 00h, 00h, 00h, 00h, 00h, 00h, 00h, 00h
<b>Memory Organization Block</b>			
80 - 83	M	Number of Data Bytes per Page (2048 Bytes)	00h, 08h, 00h, 00h
84 - 85	M	Number of Spare Bytes per Page (128 Bytes)	80h, 00h
86 - 89	M	Number of Data Bytes per Partial Page (512 Bytes)	00h, 00h, 00h, 00h
90 - 91	M	Number of Spare Bytes per Partial Page (16 Bytes)	00h, 00h
92 - 95	M	Number of Pages per Block (64 Pages)	40h, 00h, 00h, 00h



Byte #	O/M	Description	Values
96 - 99	M	Number of Blocks per Logical Unit (LUN) (2048)	00h, 08h, 00h, 00h
100	M	Number of Logical Units (LUNs)	01h
101	M	Number of address cycles Bit # Value 0 - 3 Row Address Cycles 4 - 7 Column Address Cycles	23h
102	M	Number of Bits per Cell	01h
103 - 104	M	Bad Blocks Number per LUN (40)	28h, 00h
105 - 106	M	Block Endurance (50K)	05h, 04h
107	M	Guaranteed Valid Blocks at Beginning of Target	01h
108 - 109	M	Block Endurance for Guaranteed Valid Blocks	05h, 04h
110	M	Number of Programs per Page	04h
111	M	Partial Programming Attributes Bit # Value 0 1 = Partial Page programming has Constraints 1 - 3 1 = Reserved (0) 4 1 = Partial Page Layout 5 - 7 0 = Reserved	00h
112	M	Number of Bits ECC Correctability	04h
113	M	Number of Interleaved Address Bits Bit # Value 0 - 3 Number of Interleaved Address Bits 4 - 7 Reserved (0)	01h
114	M	Interleaved Operation Attributes Bit # Value 0 Overlapped / concurrent Interleaving Support 1 1 = No Block Address Restrictions 2 1 = Program Cache Supported 3 Address Restrictions for Program Cache 4 - 7 0 = Reserved	04h
115 - 127		Reserved (0)	00h, 00h, 00h, 00h, 00h, 00h, 00h, 00h, 00h, 00h, 00h, 00h, 00h
<b>Electrical Parameter Block</b>			
128	M	I/O Pin Capacitance (10pF)	0Ah
129 - 130	M	Timing Mode Support Bit # Value 0 1 = Supports Timing mode 0 1 1 = Supports Timing mode 1 2 1 = Supports Timing mode 2 3 1 = Supports Timing mode 3 4 1 = Supports Timing mode 4 5 1 = Supports Timing mode 5 6 - 15 0 = Reserved	1Fh, 00h





## Bus Interface

As mentioned above, the I/O bus on the device is multiplexed. Commands, addresses and data input/output all share the same I/O pins. Commands and addresses are always supplied on I/O[7:0]. Data uses I/O [7:0] for x8 configuration and uses I/O[15:0] for x16 configuration.

The read, program or erase command sequences typically consist of a command input cycle, two or five address input cycles, and one or more data cycles, either input or output.

Table 10: Device Modes Selection

Mode	CE#	CLE	ALE	WE#	RE#	WP#	I/O[x]
Standby	V <sub>IH</sub>	V <sub>IH</sub> / V <sub>IL</sub>	V <sub>IH</sub> / V <sub>IL</sub>	V <sub>IH</sub> / V <sub>IL</sub>	V <sub>IH</sub> / V <sub>IL</sub>	V <sub>CC</sub> / V <sub>SS</sub>	V <sub>IH</sub> / V <sub>IL</sub>
Command Input	V <sub>IL</sub>	V <sub>IH</sub>	V <sub>IL</sub>	↑	V <sub>IH</sub>	V <sub>IH</sub>	Data
Address Input	V <sub>IL</sub>	V <sub>IL</sub>	V <sub>IH</sub>	↑	V <sub>IH</sub>	V <sub>IH</sub>	Data
Data Input	V <sub>IL</sub>	V <sub>IL</sub>	V <sub>IL</sub>	↑	V <sub>IH</sub>	V <sub>IH</sub>	Data
Data Output	V <sub>IL</sub>	V <sub>IL</sub>	V <sub>IL</sub>	V <sub>IH</sub>	↓	V <sub>IH</sub> / V <sub>IL</sub>	Data
Write Protect	V <sub>IH</sub> / V <sub>IL</sub>	V <sub>IH</sub> / V <sub>IL</sub>	V <sub>IH</sub> / V <sub>IL</sub>	V <sub>IH</sub> / V <sub>IL</sub>	V <sub>IH</sub> / V <sub>IL</sub>	V <sub>IL</sub>	V <sub>IH</sub> / V <sub>IL</sub>

Notes:

1. V<sub>IH</sub> = High (Logic '1'), V<sub>IL</sub> = Low (Logic '0')

### Standby

The device enters standby when CE# pin is driven V<sub>IH</sub> (High). This helps reduce power consumption. In standby mode, all I/Os are tri-stated (High-Z).

**Note:** The device enters standby if CE# goes High and the device is not busy (no program/erase operations in progress).

### Busy

The device enters busy when program, erase or read operations are initiated. The device returns to Standby after the completion of the operation. During busy state, only RESET (FFh) and READ STATUS REGISTER (70h) commands are accepted by the device.

Table 11: Recommended Signal Selections During Busy

Mode	CE#	CLE	ALE	WE#	RE#	WP#	I/O[x]
Busy Period (READ)	V <sub>IH</sub> / V <sub>IL</sub>	V <sub>IH</sub> / V <sub>IL</sub>	V <sub>IH</sub> / V <sub>IL</sub>	V <sub>IH</sub> / V <sub>IL</sub>	V <sub>IH</sub> / V <sub>IL</sub>	V <sub>IH</sub> / V <sub>IL</sub>	V <sub>IH</sub> / V <sub>IL</sub>
Busy Period (Program)	V <sub>IH</sub> / V <sub>IL</sub>	V <sub>IH</sub> / V <sub>IL</sub>	V <sub>IH</sub> / V <sub>IL</sub>	V <sub>IH</sub> / V <sub>IL</sub>	V <sub>IH</sub> / V <sub>IL</sub>	V <sub>IH</sub>	V <sub>IH</sub> / V <sub>IL</sub>
Busy Period (Erase)	V <sub>IH</sub> / V <sub>IL</sub>	V <sub>IH</sub> / V <sub>IL</sub>	V <sub>IH</sub> / V <sub>IL</sub>	V <sub>IH</sub> / V <sub>IL</sub>	V <sub>IH</sub> / V <sub>IL</sub>	V <sub>IH</sub>	V <sub>IH</sub> / V <sub>IL</sub>

Notes:

1. V<sub>IH</sub> = High (Logic '1'), V<sub>IL</sub> = Low (Logic '0')

### Device Protection (Write Protect WP#)

The write protect# (WP#) signal enables or disables PROGRAM and ERASE operations within the Flash device. When WP# is Low, PROGRAM and ERASE operations are disabled. When WP# is High, PROGRAM and ERASE operations are enabled.

It is recommended that the host drive WP# Low during power-on until VCC is stable to prevent inadvertent PROGRAM and ERASE operations.

WP# must be transitioned only when the device is in Standby and prior to beginning a command sequence. After a command sequence is complete and the device is ready, WP# can be transitioned. After WP# is transitioned, the host must wait  $t_{ww}$  before issuing a new command.

The WP# signal is always an active input, even when CE# is High. This signal should not be multiplexed with other signals.

### Command Input

A command is entered from I/O[7:0] to the command register on the rising edge of WE# when CE# is Low, ALE is Low, CLE is High, and RE# is High. Most commands are ignored if the device is busy (R/B# = 0); however, some commands, including READ STATUS (70h), are accepted. For devices with a x16 interface, I/O[15:8] must be written with zeros when a command is issued.

Figure 4: Command Latch Cycle

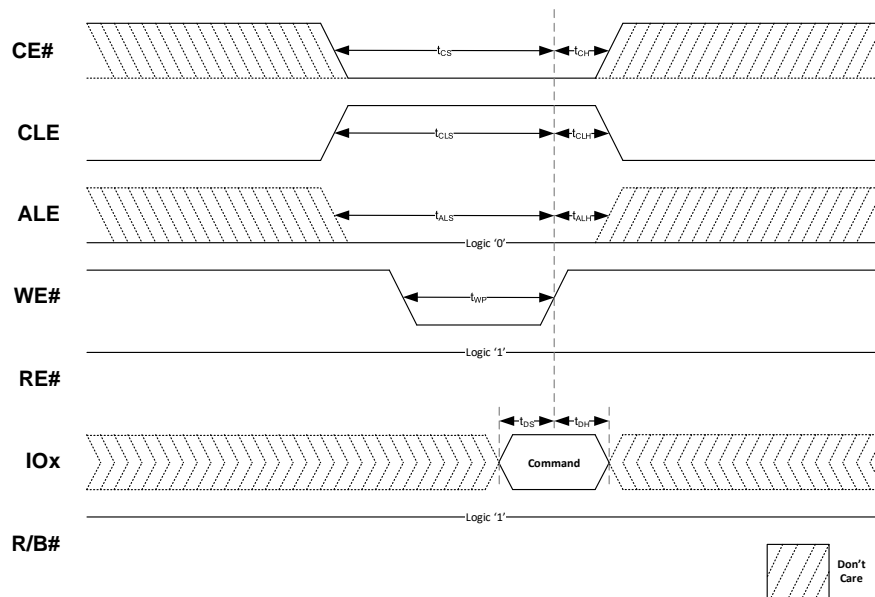

### Address Input

An address is entered to the address register on the rising edge of WE# when CE# is Low, ALE is High, CLE is Low, and RE# is High. Bits that are not part of the address space must be Low (see Array Addressing Sequences). The number of address cycles required depends on the command (refer to the command descriptions to determine addressing requirements). Addresses are input on I/O[7:0] on x8 devices and on I/O[15:0] on x16 devices. Moreover, for commands that start a modify operation (program/erase), WP# must be high.

Figure 5: Address Latch Cycle

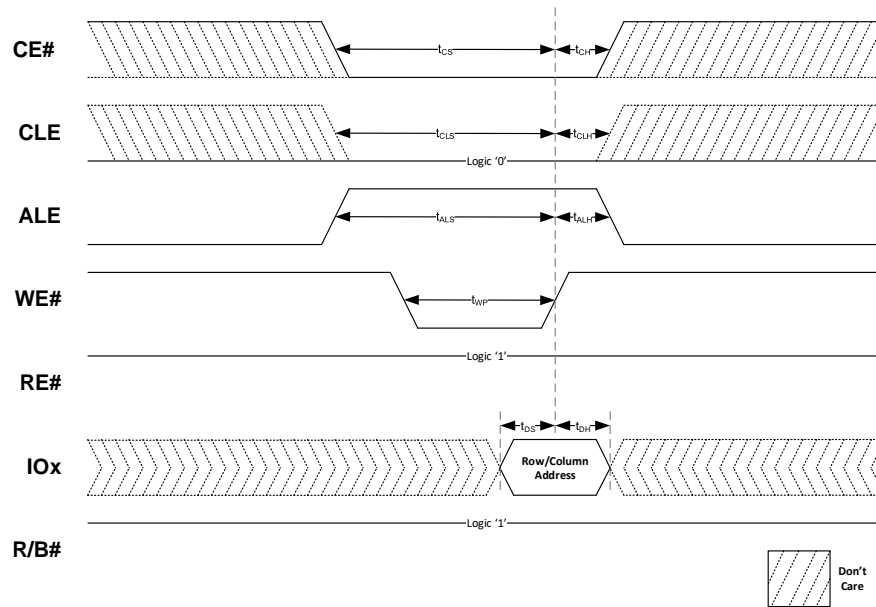

## Data Input

Data is entered to the page buffer (cache register and/or data register) on the rising edge of WE# when CE# is Low, ALE is Low, CLE is Low, and RE# is High. Data input is ignored if the device is busy (R/B# = 0). Data is input on I/O[7:0] on x8 devices and on I/O[15:0] on x16 devices.

Figure 6: Data Input Cycle

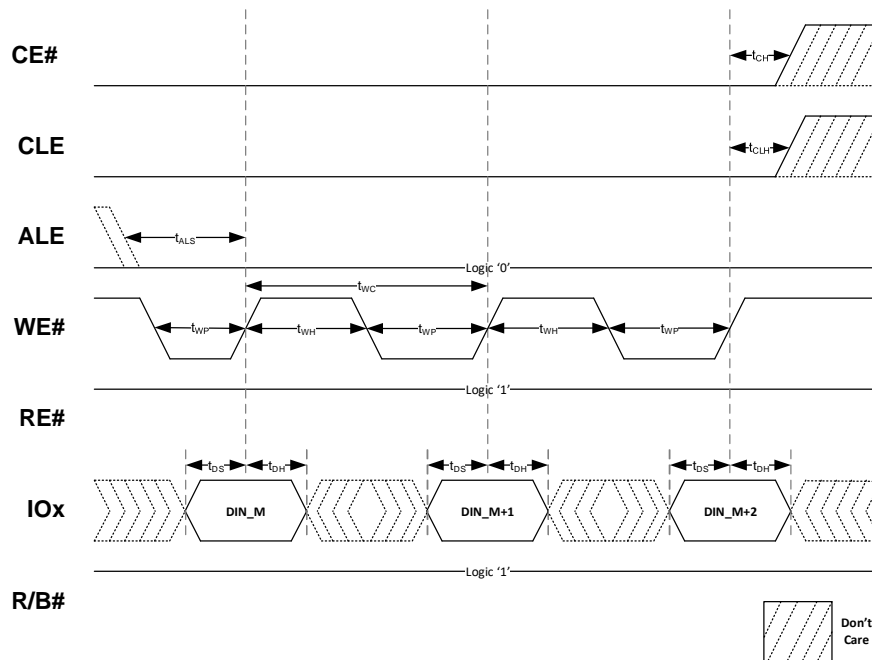

## Data Output

Data can only be output if the device is not busy and is in the READ state. Data output is supported following a READ operation from the NAND Flash array. Data is output from the cache register on the falling edge of RE# when CE# is Low, ALE is Low, and WE# is High. Data is output on I/O[7:0] on x8 devices and on I/O[15:0] on x16 devices.

Figure 7: Data Output Cycle

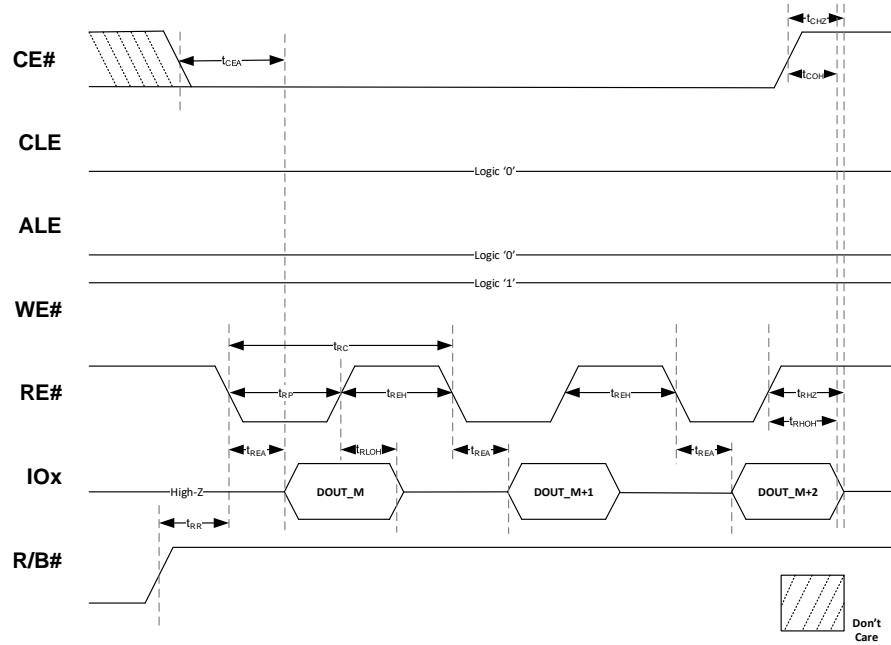

**Command Set**

## Single Plane Commands

Table 12: Single Plane Command Set

Operation	Command Cycle #1	Address Cycles	Data Input Cycles	Command Cycle # 2	Command Accepted Device Busy
<b>Reset Operation</b>					
RESET	FFh	0	0	N/A	Yes
<b>Identification Operations</b>					
READ ID	90h	1	0	N/A	No
READ UNIQUE ID	EDh	1	0	N/A	No
READ PARAMETER PAGE	ECh	1	0	N/A	No
<b>Status Register Operation</b>					
READ STATUS REGISTER	70h	0	0	N/A	Yes
<b>Read Operations</b>					
READ MODE	00h	0	0	N/A	No
READ PAGE	00h	5	0	30h	No
READ PAGE CACHE (Start)	31h	0	0	N/A	No
READ PAGE CACHE (End)	00h	5	0	31h	No
READ PAGE CACHE (Random)	3Fh	0	0	N/A	No
READ RANDOM DATA	05h	2	0	E0h	No
<b>Program Operations</b>					
PROGRAM PAGE	80h	4	Yes	10h	No
PROGRAM PAGE CACHE (End)	80h	4	Yes	10h	No
PROGRAM PAGE CACHE (Start)	80h	4	Yes	15h	No
RANDOM DATA INPUT	85h	2	Yes	N/A	No
<b>Re-Program Operations</b>					
PROGRAM PAGE 2 (RE-PROGRAM)	8Bh	5	Yes	10h	No
<b>Erase Operation</b>					
ERASE BLOCK	60h	3	No	D0h	No
<b>Data Move Operations (Internal)</b>					
READ FOR DATA MOVE	00h	5	No	35h	No
PROGRAM FOR DATA MOVE	85h	5	Optional	10h	No
<b>One-Time Programmable (OTP) Region Operations</b>					
OTP REGION ENTRY	29h-17h-04h-19h	0	0	N/A	No

## Multi-Plane (MP) / Multi-Device (MD) Commands

Table 13: Multi-Plane / Multi-Device Command Set

Operation	CMD Cycle #1	ADDR Cycles	CMD Cycle #2	ADDR Cycles	CMD Cycle #2	ADDR Cycles	CADB
<b>Program Operations</b>							
PROGRAM PAGE MP	80h 80h	5 5	11h - 81h 11h - 80h	5 5	10h 10h	-	No
PROGRAM PAGE CACHE MP (END)	80h 80h	5 5	11h - 81h 11h - 80h	5 5	10h 10h	-	No
PROGRAM PAGE CACHE MP	80h 80h	5 5	11h - 81h 11h - 80h	5 5	15h 15h	-	No
<b>Erase Operations</b>							
ERASE BLOCK MP	60h 60h	3 3	60h D1h - 60h	3 3	D0h D0h	-	No
<b>Data Move Operations (Internal)</b>							
PROGRAM FOR DATA MOVE MP	85h 85h	5 5	11h - 81h 11h - 85h	5 5	10h 10h	-	No
<b>Status Register Operation</b>							
READ STATUS REGISTER MP/MD	78h	3	-	-	-	-	Yes

### RESET Operation (FFh)

The RESET command (FFh) places the NAND Flash device into the standby mode and aborts any command sequence in progress. READ, PROGRAM, and ERASE commands can be aborted while the device is in the busy state using the RESET command. The contents of the memory location being programmed, or the block being erased are no longer valid - the data may be partially erased or programmed and is invalid. The command register is cleared and is ready for the next command. The data register and cache register contents are marked invalid. The status register contains the value E0h when WP# is High; otherwise it contains the value 60h. R/B# goes Low for  $t_{RST}$  during which the device completes the reset operation.

Figure 8: RESET Operation

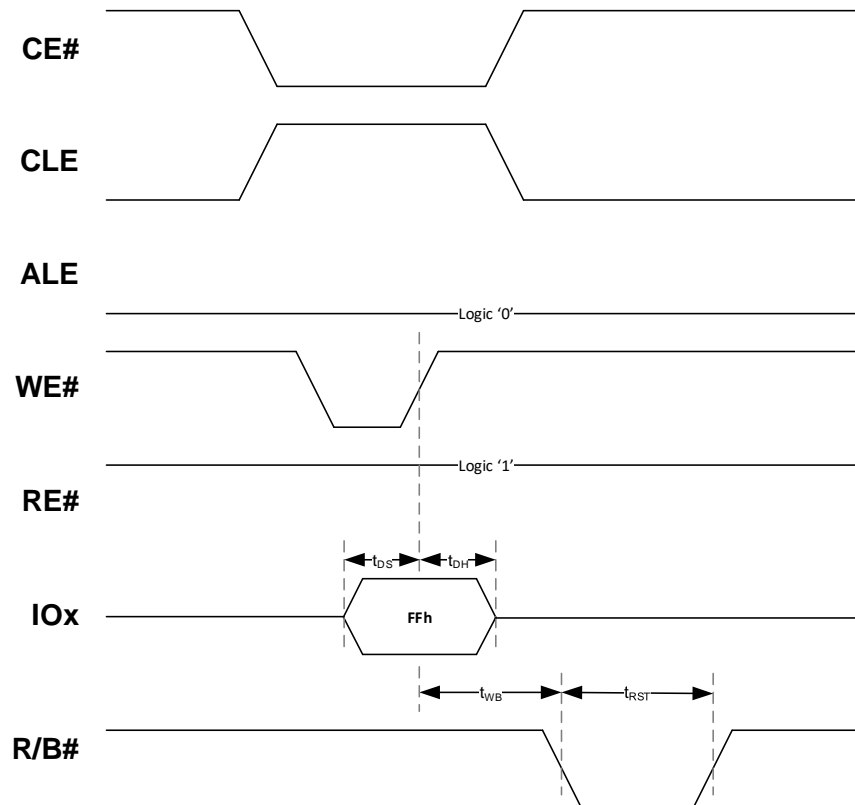

### READ ID Operation (90h)

The READ ID (90h) command is used to read the product identification information programmed into the NAND Flash device. This command is accepted when the device is in Standby mode. Writing 90h to the command register puts the device in read ID mode. The device stays in this mode until another valid command is issued.

When the 90h command is followed by an 00h address cycle, the device returns a 5-byte identifier code that includes the manufacturer ID, device configuration, and part-specific information. Reading beyond the five bytes yields indeterminate data.

When the 90h command is followed by a 20h address cycle, the device returns the 4-byte ONFI identifier code. Reading beyond the four bytes yields indeterminate data.

Note: Table 7 provides the ID values.

Figure 9: READ ID Operation

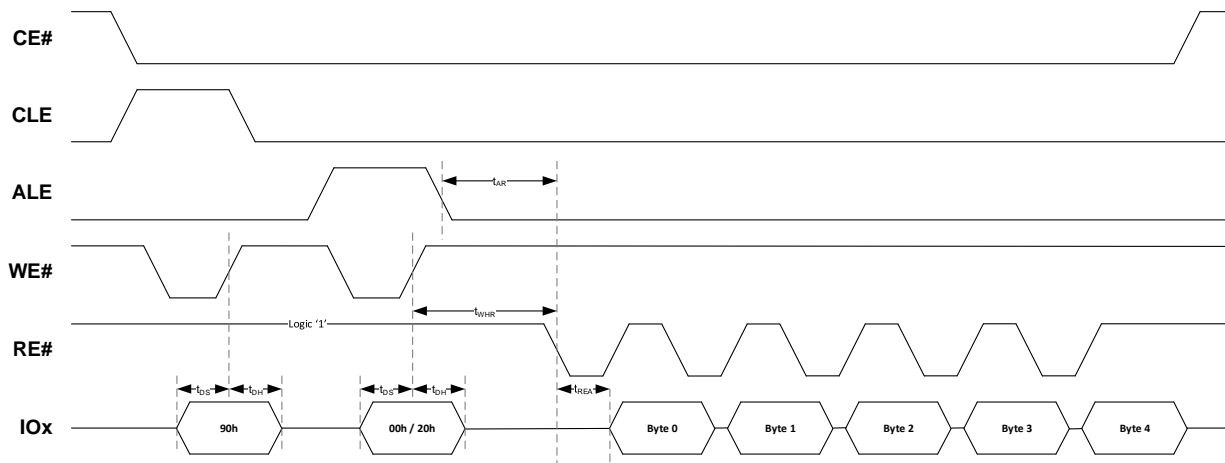

### READ UNIQUE ID Operation (EDh)

The READ UNIQUE ID (EDh) command is used to read the ONFI Unique identification information programmed into the NAND Flash device. This command is accepted when the device is in Standby mode. Writing EDh to the command register puts the device in read UNIQUE ID mode. The device stays in this mode until another valid command is issued.

When the EDh command is followed by a 00h address cycle, the device returns 16-bytes of a unique value. The next 16-bytes are the bit-wise complement of the unique value. The host can verify that the Unique ID was read correctly by performing an XOR of the two values; result should be all ones. The host must monitor the R/B# pin or wait for the maximum data transfer time ( $t_R$ ) before reading the Unique ID data.

Table 14: Unique ID Data Description

Bytes	Information
0-15	Unique ID
16-31	Unique ID Complement
32-47	Unique ID
48-63	Unique ID Complement
64-79	Unique ID
80-95	Unique ID Complement
96-111	Unique ID
112-127	Unique ID Complement
128-143	Unique ID
144-159	Unique ID Complement
160-175	Unique ID
176-191	Unique ID Complement
192-207	Unique ID
208-223	Unique ID Complement
224-239	Unique ID
240-255	Unique ID Complement
256-271	Unique ID



Bytes	Information
272-287	Unique ID Complement
288-303	Unique ID
304-319	Unique ID Complement
320-335	Unique ID
336-351	Unique ID Complement
352-367	Unique ID
368-383	Unique ID Complement
384-399	Unique ID
400-415	Unique ID Complement
416-431	Unique ID
432-447	Unique ID Complement
448-463	Unique ID
464-479	Unique ID Complement
480-495	Unique ID
496-511	Unique ID Complement

Figure 10: READ Unique ID Operation

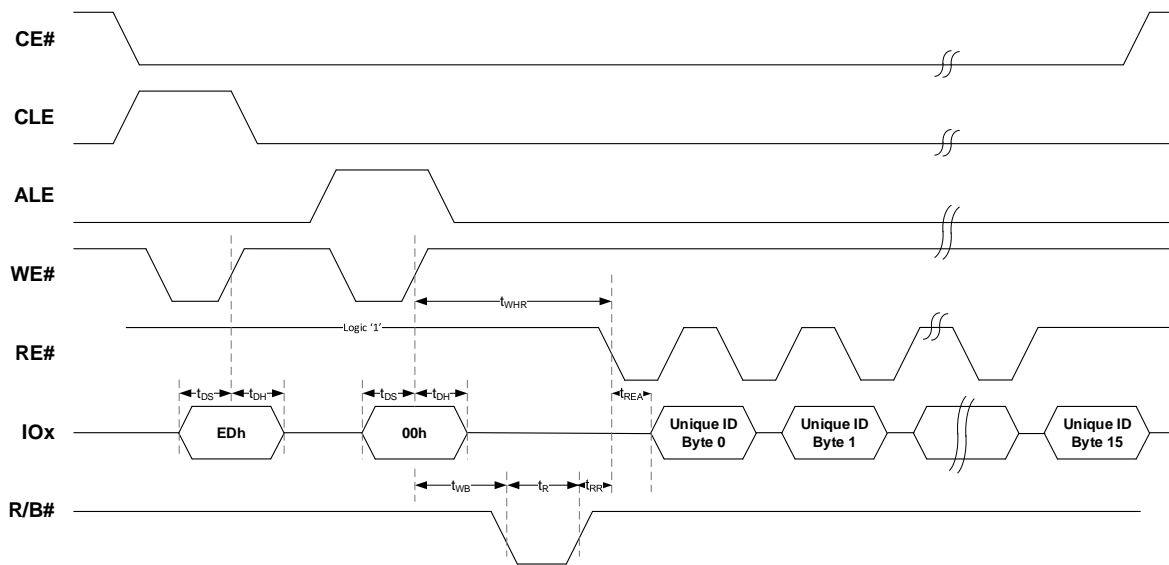

### READ PARAMETER PAGE Operation (ECh)

The READ PARAMETER PAGE (ECh) command is used to read the ONFI parameter page which describes the device's organization, features, timings and other behavioral parameters. These values are static and cannot be altered by the user. The READ PARAMETER PAGE command is accepted by the device when it is in Standby mode.

Writing ECh to the command register puts the device in read parameter page mode. It stays in this mode until another valid command is issued. When the ECh command is followed by an 00h address cycle, the device goes busy for  $t_R$ . If desired, the RANDOM DATA OUTPUT (05h-E0h) command can be used to change the location of data output. If the READ STATUS (70h) command is used to monitor for command completion, the READ MODE (00h) command must be used to re-enable data output mode.

Figure 11: Parameter Read Operation

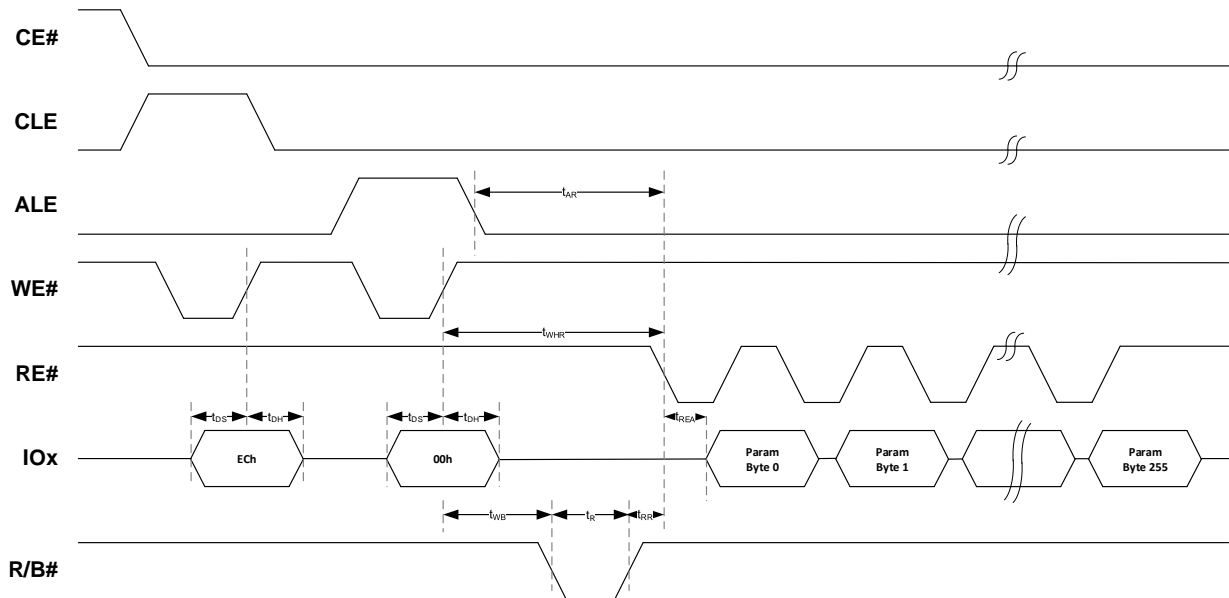

### READ STATUS REGISTER Operation (70h)

The device provides its status through its 8-bit status register. After the READ STATUS REGISTER (70h) command is issued, status register output is enabled. The contents of the status register are returned on I/O[7:0] for each data output request (toggle RE#).

When the status register output is enabled, changes in the status register are seen on I/O[7:0] as long as CE# and RE# are Low; it is not necessary to toggle RE# to see the status register update. The command register remains in Status Read mode until another valid command is issued to it.

Figure 12: Read Status Register Operation

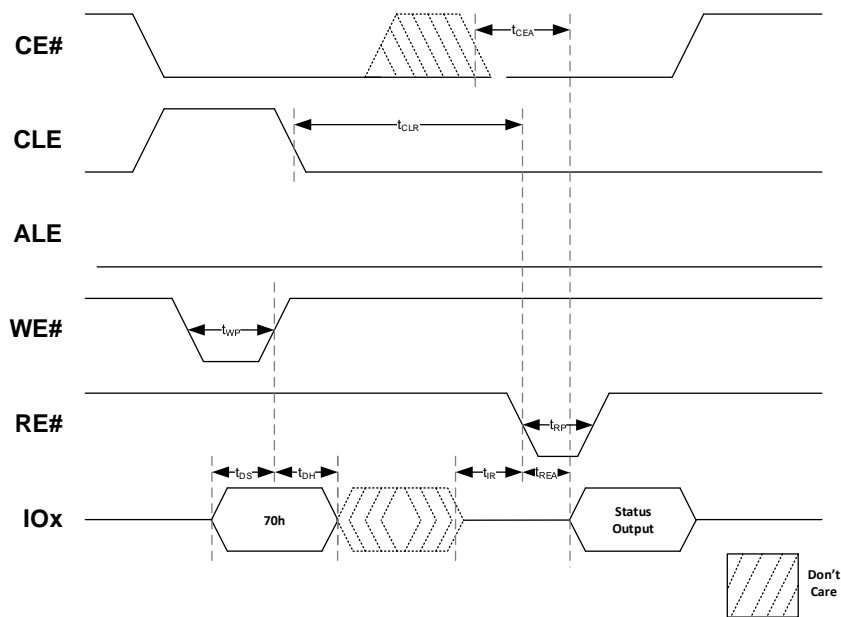

## READ MODE Operation (00h)

Upon initial device power up, the device defaults to Read mode. This operation is also initiated by writing 00h and 30h to the command register along with four address cycles. Two types of read operations are available: random read and serial page read. The random read mode is enabled when the page address is changed. The repetitive high to low transitions of the RE# clock make the device output the data starting from the selected column address up to the last column address. The device may output random data in a page instead of the consecutive sequential data by writing random data output command. Random data output can be operated multiple times regardless of how many times it is done in a page. Any operation other than read or random data output causes the device to exit read mode.

The READ MODE (00h) command enables data output and disables status output after a READ operation (00h-30h, 00-31h) has been modified with a status operation (70h). This command is accepted by the device when it is ready (RDY = 1, ARDY = 1). It is also accepted by the device during READ PAGE CACHE (31h, 00h-31h) operations (RDY = 1 and ARDY = 0).

## READ PAGE Operation (00h – 30h)

The READ PAGE (00h–30h) command copies a page (x8: 2176 bytes, x16: 1088 words) from the NAND Flash array to its cache register and enables data output. This command is accepted by the device when it is ready (RDY = 1, ARDY = 1).

To read a page from the NAND Flash array, the host must first write the 00h command to the command register, followed by writing 5 address cycles to the address registers, and conclude with writing the 30h command. The device will go busy (RDY = 0, ARDY = 0) for  $t_R$  as data is transferred. To determine the progress of the data transfer, the host can monitor the device's R/B# signal or use the READ STATUS REGISTER operation (70h). If the READ STATUS REGISTER operation is used to monitor the progress, the host must disable status output and enable data output by issuing the READ MODE (00h) command when the device gets ready (RDY = 1, ARDY = 1).

As mentioned above, two types of read operations are available: random read and serial page read. During data output the READ RANDOM DATA (05h-E0h) command can be issued if random data output from the page is desired. Otherwise, the data output is sequential.

Figure 13: Read Page Operation

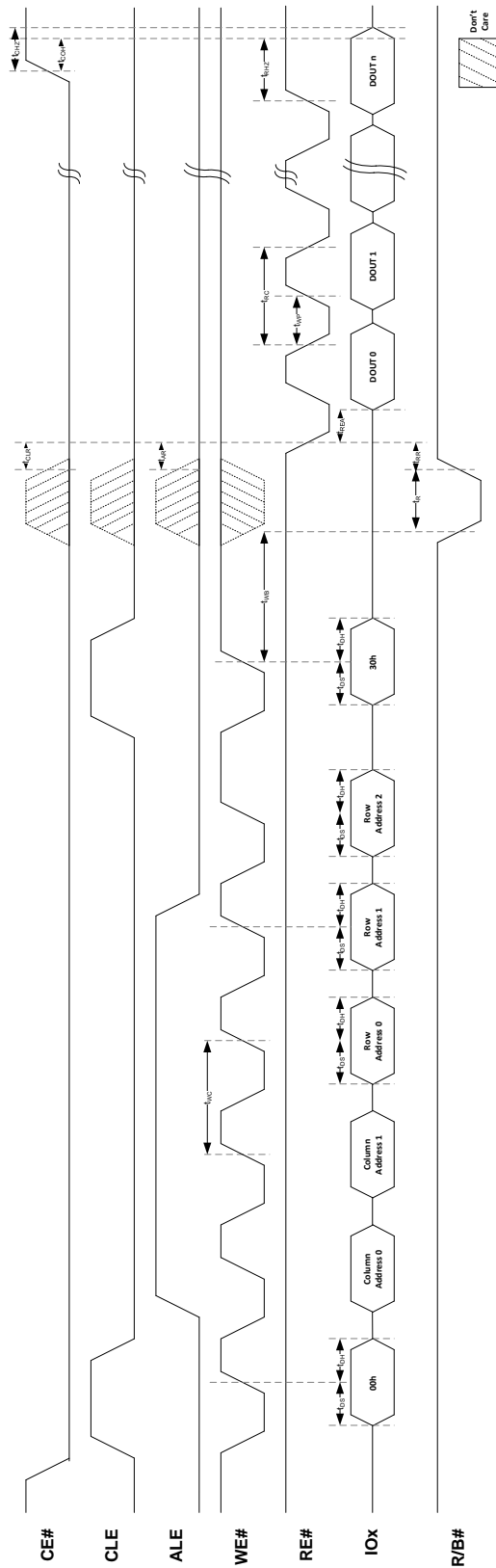
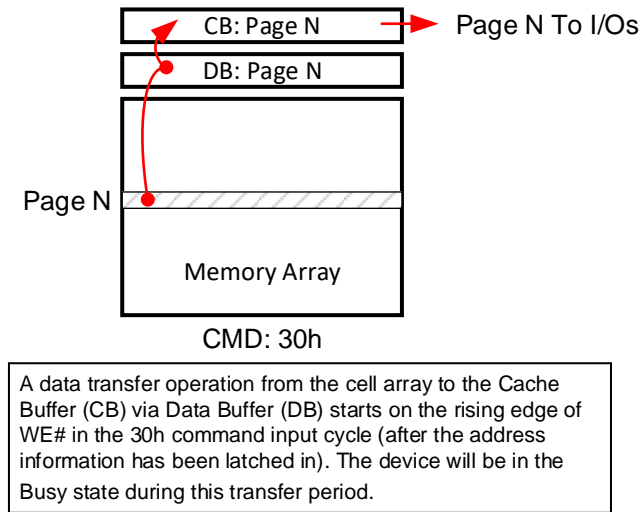

Figure 14: Read Page Operation Overview



### READ PAGE CACHE Start Operation (31h)

The READ PAGE CACHE Start (31h) command allows reading a page from the cache register while another page is simultaneously loaded from the Flash array into the data register. A READ PAGE (00h–30h) command must be issued prior to the READ PAGE CACHE Start command. Operationally, the READ PAGE CACHE Start (31h) command reads the next sequential page within a block into the data register (while the previous page is output from the cache register). This command is accepted by the device when it is ready (RDY = 1, ARDY = 1). It is also accepted during READ PAGE CACHE (31h, 00h-31h) operation (RDY = 1 and ARDY = 0).

To issue this command, write 31h to the command register. After this command is issued, R/B# goes Low and the device is busy (RDY = 0, ARDY = 0) for  $t_{RBSY}$ . After  $t_{RBSY}$ , R/B# goes High (RDY = 1, ARDY = 0), indicating that the cache register is available and that the specified page is being copied from the NAND Flash array to the data register. At this point, data can be output from the cache register beginning at column address 0. The READ RANDOM DATA (05h-E0h) command can be used to change the column address of the data being output from the cache register.

The READ PAGE CACHE Start (31h) command must not cross block boundaries. The host can enter the address of the next page to be read from the Flash array. If the host does not enter an address to retrieve, the next sequential page is read. When no more pages are to be read, the final page is copied into the page register by issuing the READ PAGE CACHE End (3Fh) command.

Figure 15: Read Page Cache Start Operation

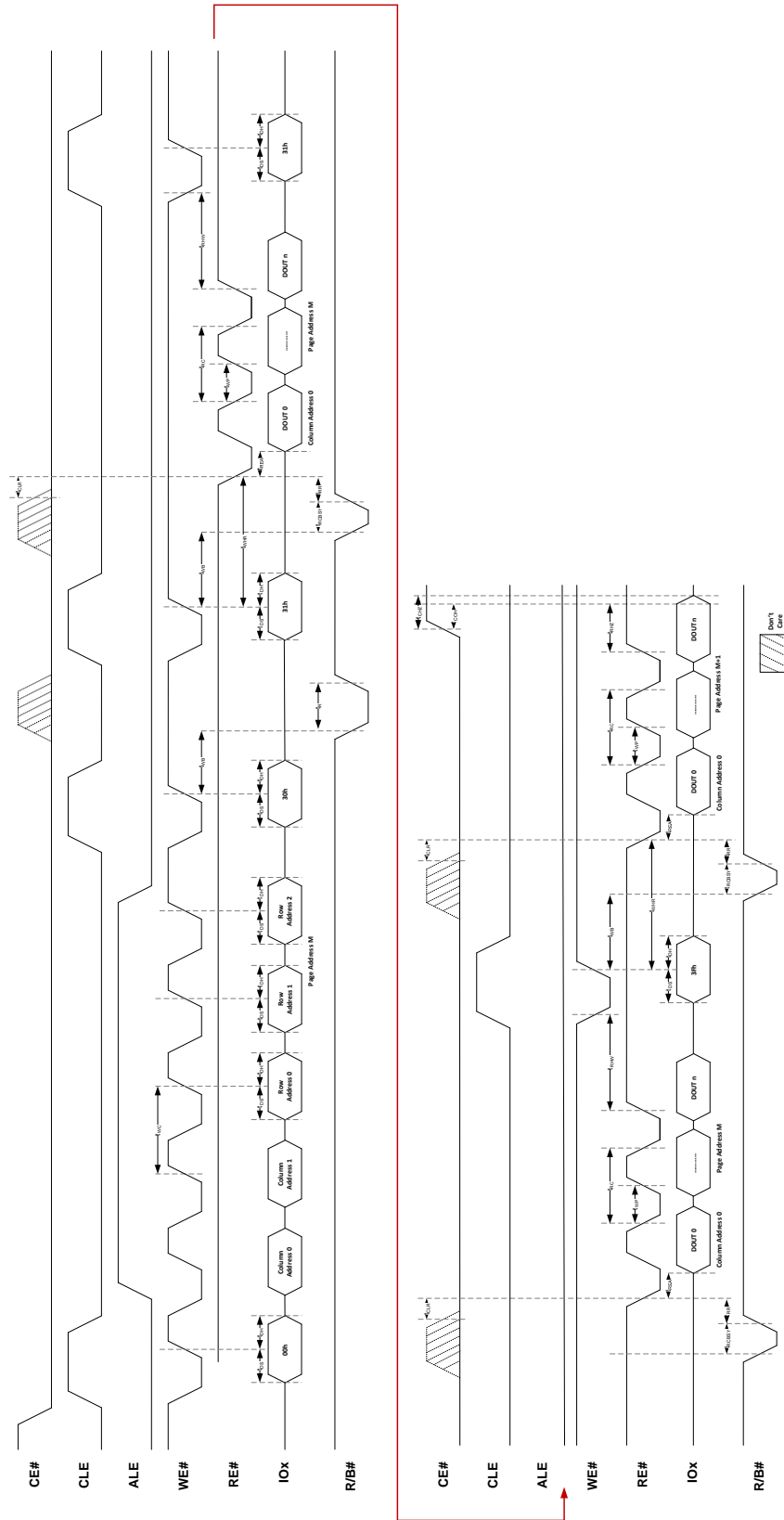
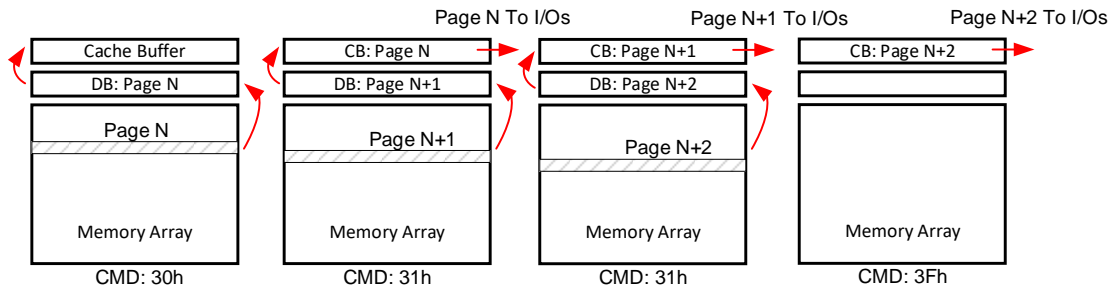

Figure 16: Read Page Cache Start Operation Overview



When 31h command is issued to the device, the data content of the next page is transferred to the Data Buffer (DB) during serial output of the Cache Buffer (CB).

- During Normal read, Data is transferred from Page N to CB through DB. During this time period, the device outputs Busy state for  $t_{R}$ .
- After the Ready/Busy returns to Ready, 31h command is issued and data is transferred from DB to CB again. This data transfer takes  $t_{RBSY}$ .
- Data of Page N+1 is transferred to DB while the data of Page N in CB can be read out by RE# clock simultaneously.
- The 31h command makes data of Page N+1 transfer to CB from DB after the completion of the transfer from cell to DB. The device outputs Busy state for  $t_{RBSY}$ .
- Data of Page N+2 is transferred to DB while the data of Page N+1 in CB can be read out by RE# clock simultaneously.
- The 3Fh command makes the data of Page N+2 transfer to the CB from the DB after the completion of the transfer to DB. The device outputs Busy state for  $t_{RBSY}$ .
- Data of Page N+2 in CB can be read out.

## READ PAGE CACHE Random Operation (00h - 31h)

The READ PAGE CACHE RANDOM (00h-31h) command allows reading a page from the cache register while another page is simultaneously loaded from the Flash array into the data register. However, the page address can be randomly selected (not sequential). A READ PAGE (00h – 30h) command must be issued prior to the READ PAGE CACHE RANDOM command. This command is accepted by the device when it is ready (RDY = 1, ARDY = 1). It is also accepted during READ PAGE CACHE (31h, 00h-31h) operation (RDY = 1 and ARDY = 0).

To issue this command, write 00h to the command register, followed by writing 5 address cycles to the address register and conclude by writing 31h to the command register. Note that the column address in the address specified is ignored. After this command is issued, R/B# goes Low and the device is busy (RDY = 0, ARDY = 0) for  $t_{RBSY}$ . After  $t_{RBSY}$ , R/B# goes High (RDY = 1, ARDY = 0) indicating that the cache register is available and that the specified page is being copied from the NAND Flash array to the data register.

The data in the cache register can be read beginning at column address 0. The READ RANDOM DATA (05h-E0h) command can be used to change the column address of the data being output from the cache register.

Figure 17: Read Page Cache Random Operation

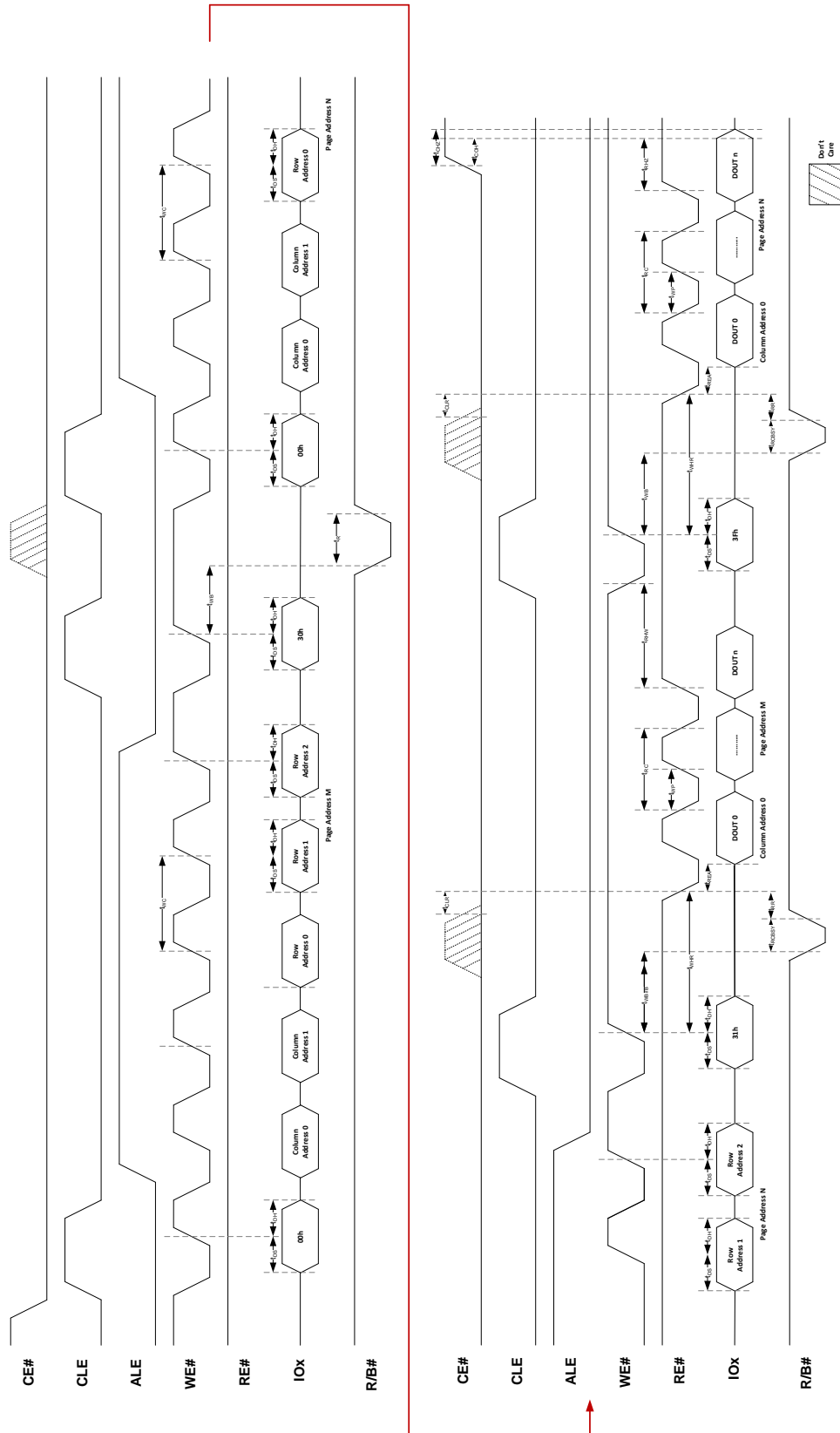



## READ PAGE CACHE End Operation (3Fh)

The READ PAGE CACHE End (3Fh) command ends the read page cache sequence and copies a page from the data register to the cache register. This command is accepted by the device when it is ready (RDY = 1, ARDY = 1). It is also accepted by the die (LUN) during READ PAGE CACHE (31h, 00h-31h) operations (RDY = 1 and ARDY = 0).

To issue the READ PAGE CACHE End (3Fh) command, write 3Fh to the command register. After this command is issued, R/B# goes LOW and device is busy (RDY = 0, ARDY = 0) for  $t_{RBSY}$ . After  $t_{RBSY}$ , R/B# goes HIGH and the device is ready (RDY = 1, ARDY = 1). At this point, data can be output from the cache register, beginning at column address 0. The READ RANDOM DATA (05h-E0h) command can be used to change the column address of the data being output from the cache register.

## READ RANDOM DATA Operation (05h – E0h)

The READ RANDOM DATA (05h-E0h) command changes the column address of the selected cache register and enables data output from the device. This command is accepted when the device is ready (RDY = 1; ARDY = 1) or during CACHE READ operations (RDY = 1; ARDY = 0).

Writing 05h to the command register, followed by two column address cycles containing the column address, followed by the E0h command, puts the device into data output mode. After the E0h command cycle is issued, the host must wait at least  $t_{WHR}$  before requesting data output. The device stays in data output mode until another valid command is issued.

Figure 18: Read Random Operation

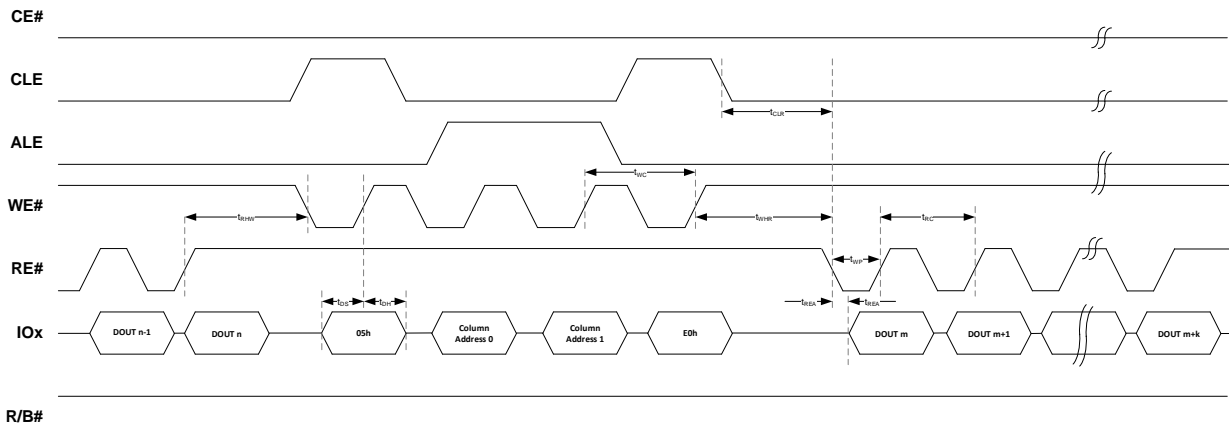

## PROGRAM PAGE / PROGRAM PAGE CACHE End Operation (80h – 10h)

As mentioned in the architecture section, programming is page based. Pages must be programmed sequentially within a block. However, the device also allows multiple partial page programming in a single page program cycle; Partial page programming of consecutive bytes (1 to 2176) or words (1 to 1088) in a single page program cycle. The number of consecutive partial page programming operation within the same page without an intervening erase operation must not exceed 4; for example, 2 times for main array (1time/512byte) and 2 times for spare array (1time/16byte).

The PROGRAM PAGE (80h-10h) command enables the host to input data to a cache register and program it to the addressed block and page in the Flash array. This command is accepted by the device when it is ready (RDY = 1, ARDY = 1). It is also accepted when the device is busy with a PROGRAM PAGE CACHE (80h-15h) operation (RDY = 1, ARDY = 0). Note that (80h-10h) command is also used to end the program page cache operation.



To program an addressed page in the Flash array, write 80h to the command register. Write 5 address cycles containing the column address and row address. Data input cycles follow. Serial data is input beginning at the column address specified. At any time during the data input cycle the RANDOM DATA INPUT command can be issued. When data entry is complete, write 10h to the command register. The device will go busy (RDY = 0, ARDY = 0) for  $t_{\text{PROG}}$  as data is programmed.

The internal program state controller automatically executes the algorithms and timings necessary to program and verify, thereby freeing the system controller for other tasks. To determine the progress of the data transfer, the host can either monitor the device's R/B# signal or, execute the status operation (70h). When the device is ready (RDY = 1, ARDY = 1), the host should check the status of the Program/Erase status (PS1/PES2) bit. The internal program verify detects only errors for "1"s that are not successfully programmed to "0"s.

Figure 19: Program Page Operation

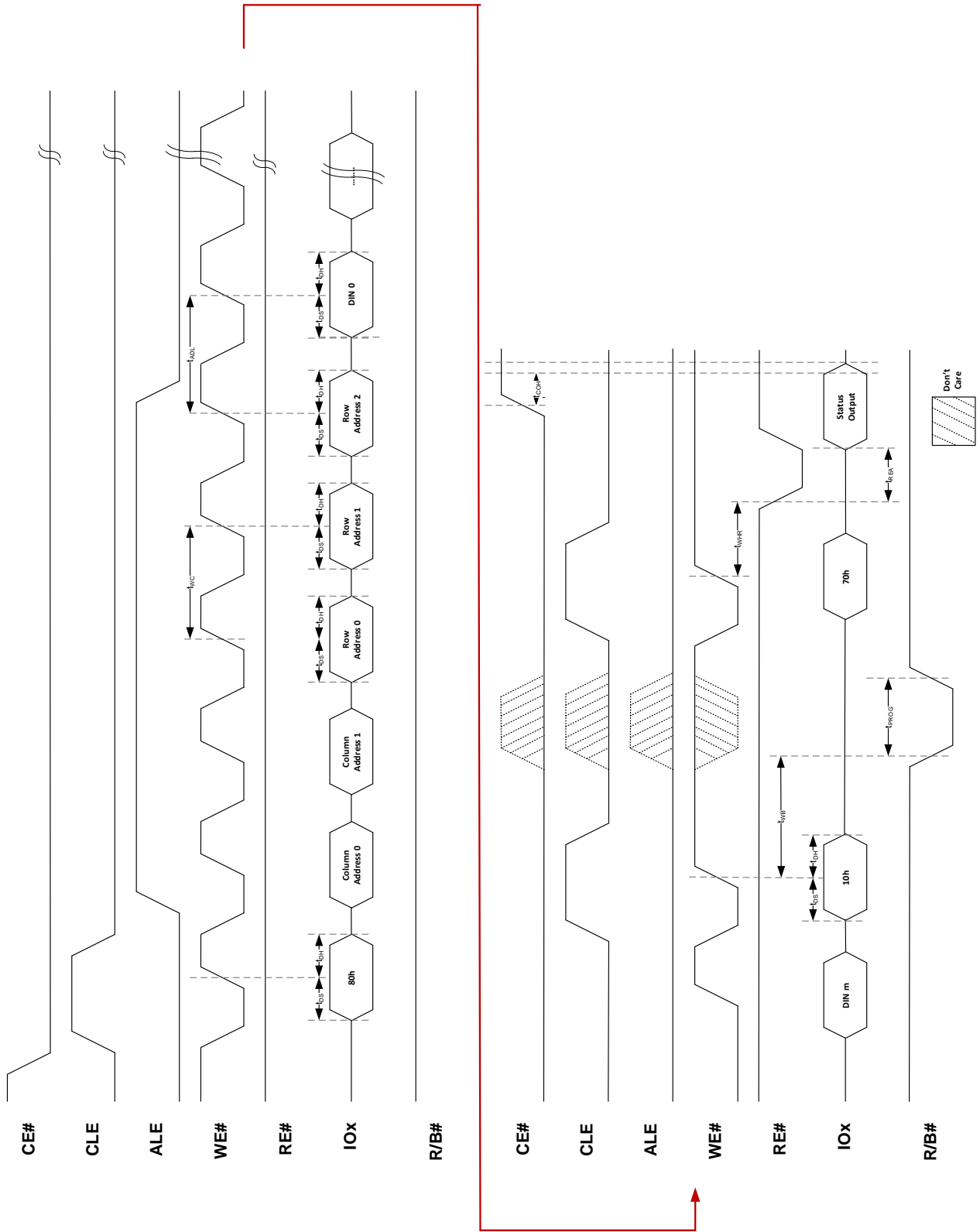
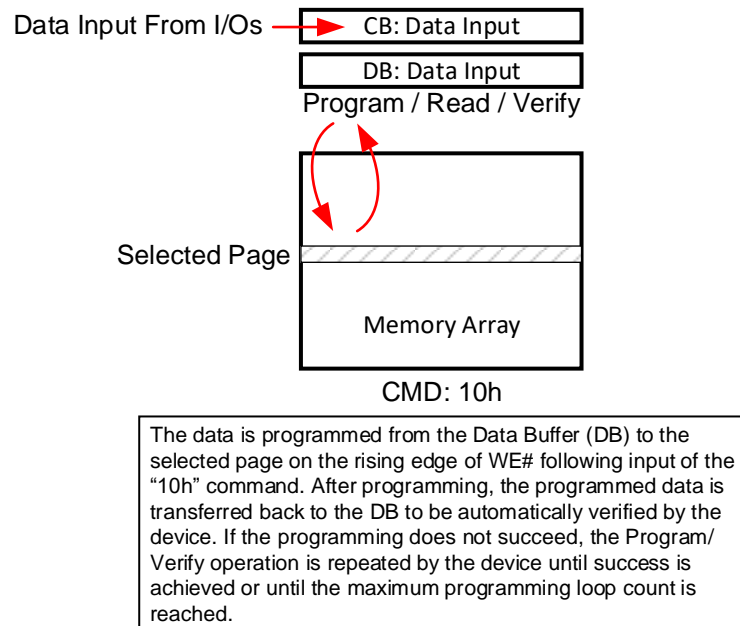

Figure 20: Program Page Operation Overview



### PROGRAM PAGE CACHE Operation (80h – 15h)

PROGRAM PAGE CACHE is used to improve the program throughput by programming data using the cache register. Cache program is available only within a block. The PROGRAM PAGE CACHE (80h-15h) command is an extension of the PROGRAM PAGE (80h-10h) command.

The PROGRAM PAGE CACHE (80h-15h) command enables the host to input data to the cache register while the data register contents are programmed to the memory array. The PROGRAM PAGE CACHE command is accepted by the device when it is ready (RDY = 1, ARDY = 1). It is also accepted by the device when it is busy with a PROGRAM PAGE CACHE operation (RDY = 1, ARDY = 0).

To input a page to the cache register, write 80h to the command register. Then write 5 address cycles containing the column address and row address. Data input cycles follow. Serial data is input beginning at the column address specified. At any time during the data input cycle the RANDOM DATA INPUT (85h) command can be issued. When data input is complete, write 15h to the command register. The device will go busy (RDY = 0, ARDY = 0) for  $t_{P_{BSY}}$  to copy data from the cache register to the data register, and then to begin the programming operation.

To determine the progress of the data transfer, the host can either monitor the device's R/B# signal or, execute the READ STATUS REGISTER (70h) command. When the device is busy with a PROGRAM PAGE CACHE operation (RDY = 1, ARDY = 0), the host must check the status of the PS1 bit to ensure cache operation was successful. If, after  $t_{P_{BSY}}$ , the host wants to wait for the program cache operation to complete without issuing PROGRAM PAGE (80h-10h) command, the host should monitor ARDY bit in the status register until it is 1. The host should then check the status of the PS1 and PES2 bits for program completion status.

Figure 21: Page Cache Program Operation

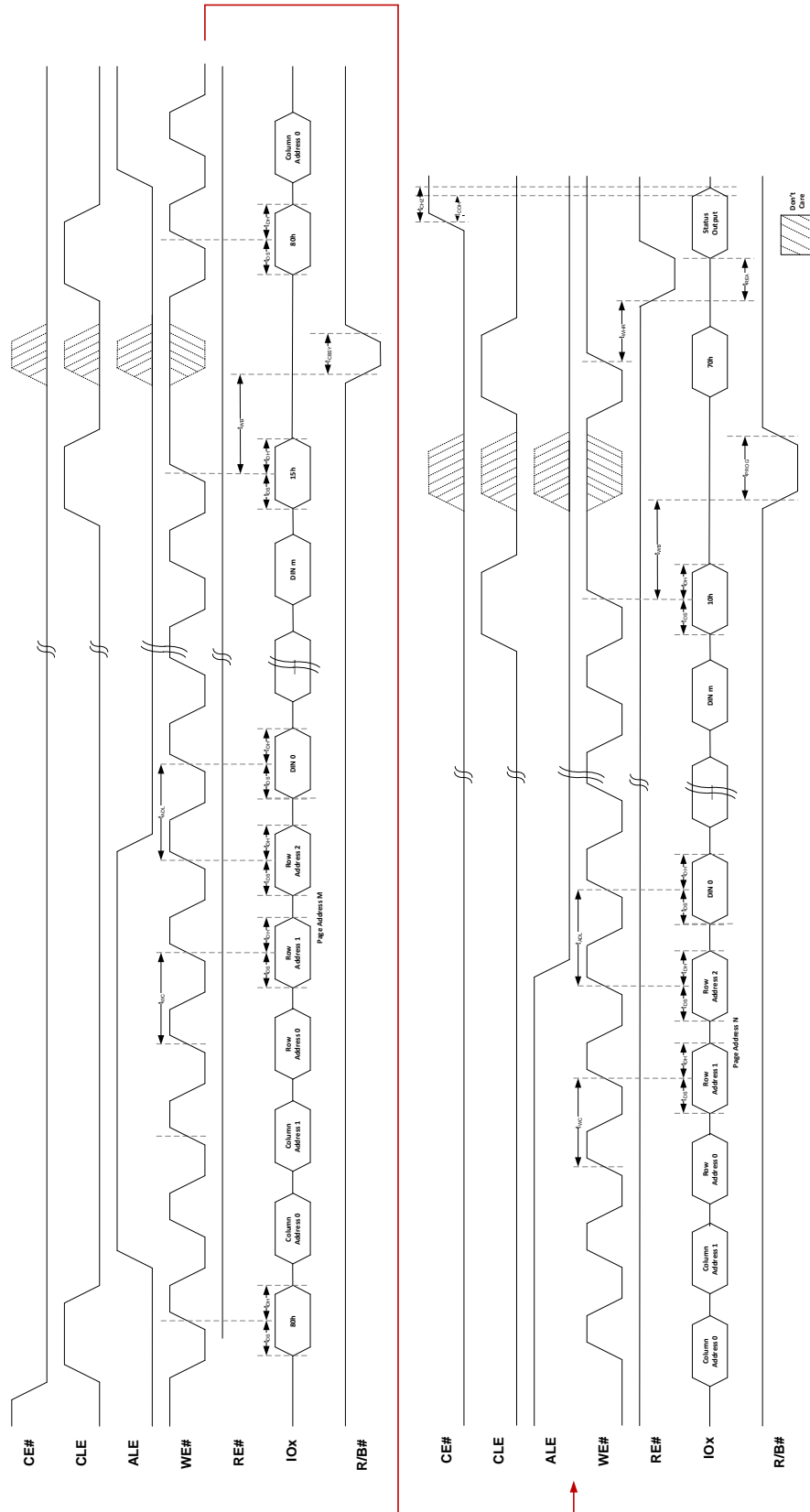
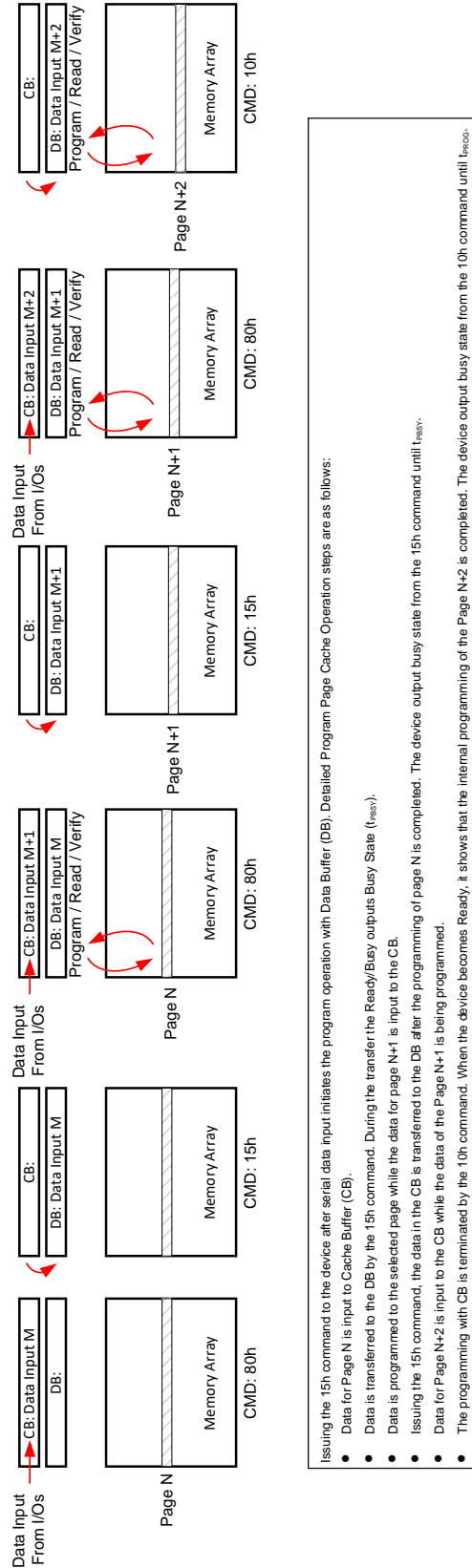

Figure 22: Page Cache Program Operation Overview



Issuing the 15h command to the device after serial data input initiates the program operation with Data Buffer (DB). Detailed Program Page Cache Operation steps are as follows:

- Data for Page N is input to Cache Buffer (CB).
- Data is transferred to the DB by the 15h command. During the transfer the Ready/Busy outputs Busy State ( $t_{RBSV}$ ).
- Data is programmed to the selected page while the data for page N+1 is input to the CB.
- Issuing the 15h command, the data in the CB is transferred to the DB after the programming of page N is completed. The device output busy state from the 15h command until  $t_{RBSV}$ .
- Data for Page N+2 is input to the CB while the data of the Page N+1 is being programmed.
- The programming with CB is terminated by the 10h command. When the device becomes Ready, it shows that the internal programming of the Page N+2 is completed. The device output busy state from the 10h command until  $t_{RBSV}$ .

## RANDOM DATA INPUT Operation (85h)

The RANDOM DATA INPUT (85h) command changes the column address and enables data input. This command is accepted by the device when it is ready ( $RDY = 1$ ;  $ARDY = 1$ ) or during PROGRAM PAGE CACHE operations ( $RDY = 1$ ;  $ARDY = 0$ ). The RANDOM DATA INPUT (85h) command is allowed after the required address cycles are specified, but prior to the final program command cycle (10h,15h) of the following commands while data input is permitted: PROGRAM PAGE (80h-10h), PROGRAM PAGE CACHE (80h-15h), and PROGRAM FOR DATA MOVE (85h-10h).

Writing 85h to the command register, followed by two column address cycles containing the column address, puts the device into data input mode. After the second address cycle is issued, the host must wait at least  $t_{ADL}$  before inputting data. The device stays in data input mode until another valid command is issued.

Figure 23: Random data Input Operation

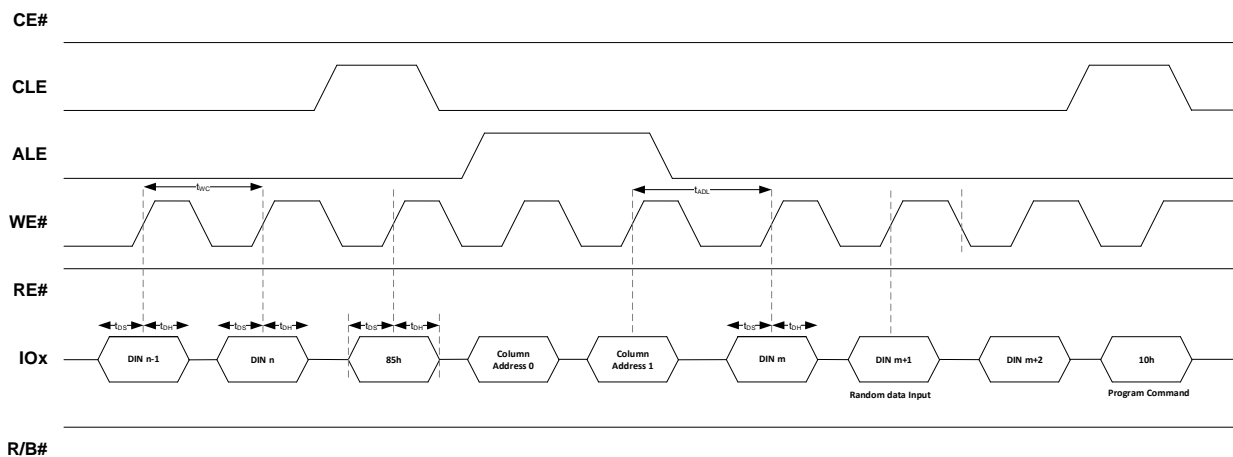

## PROGRAM PAGE 2 (RE-PROGRAM) Operation (8Bh – 10h)

The PROGRAM PAGE 2 (8Bh-10h) command allows re-programming of the same data into a new page if the last PAGE PROGRAM (80h-10h) operation failed. This command is most efficient if the data to be programmed is not changed. However, if the data needs to be altered, data in cycles can be initiated before issuing the program confirm “10h” command.

To re-program the loaded data into a new page address in the Flash array, write 8Bh to the command register. Write 5 address cycles containing the column address and row address of the new page. Data input cycles follow. Serial data is input beginning at the column address specified. At any time during the data input cycle the RANDOM DATA INPUT command can be issued. When data entry is complete, write 10h to the command register. The device will go busy ( $RDY = 0$ ,  $ARDY = 0$ ) for  $t_{PROG}$  as data is programmed.

To determine the progress of the data transfer, the host can either monitor the device's R/B# signal or, execute the status operation (70h). When the device is ready ( $RDY = 1$ ,  $ARDY = 1$ ), the host should check the status of the Program/Erase status (PS1/PES2) bits.

Figure 24: Program Page 2 (RE-PROGRAM) Operation

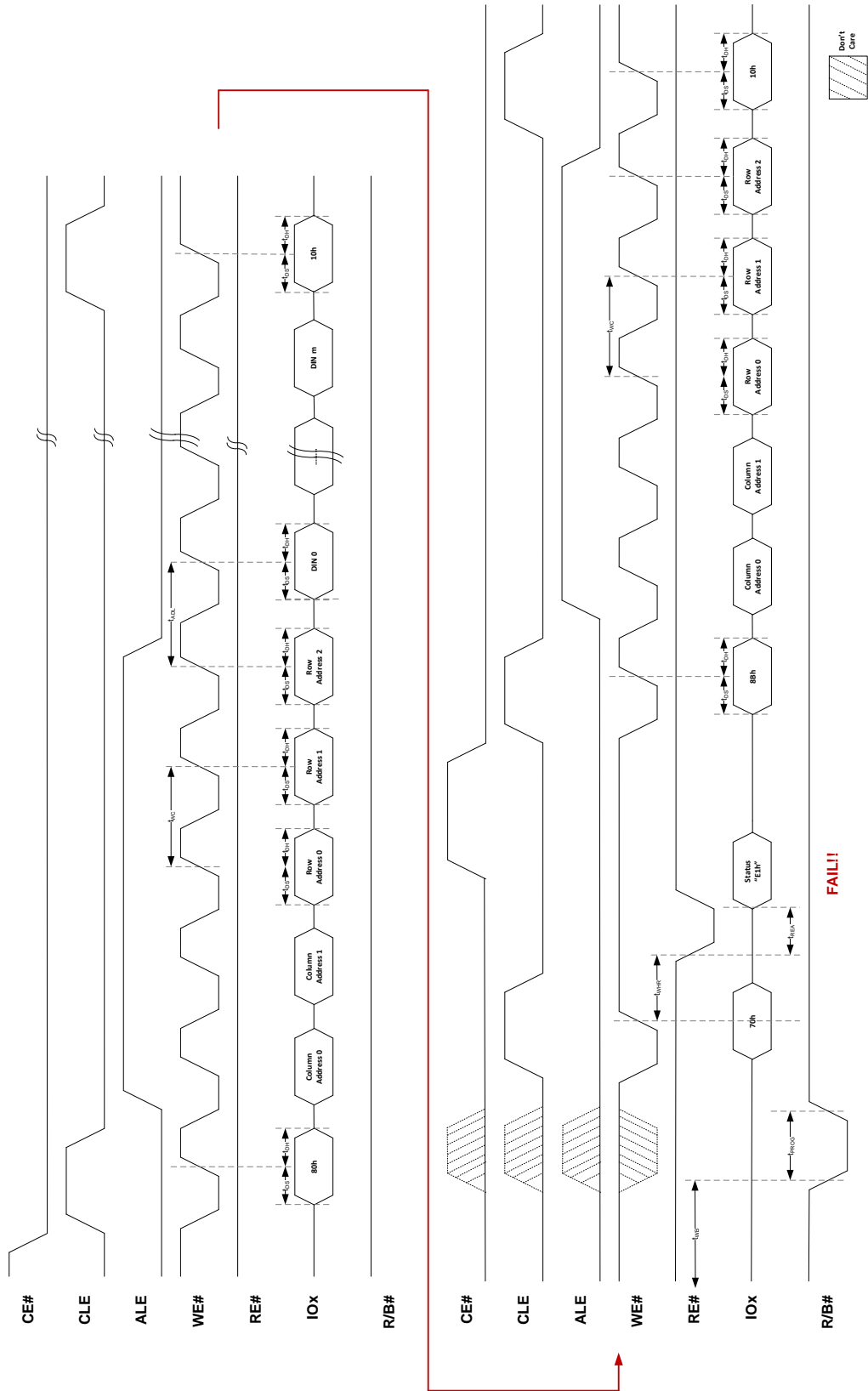



### ERASE BLOCK Operation (60h – D0h)

The erase operation in the device is done on a block basis. The ERASE BLOCK (60h-D0h) command erases the specified block in the NAND Flash array. This command is accepted by the device when it is ready (RDY = 1, ARDY = 1).

To erase a block, write 60h to the command register. Then write 3 address cycles containing the row address (the page address is not required). Conclude by writing D0h to the command register. The device will go busy (RDY = 0, ARDY = 0) for  $t_{BERS}$  while the block is erased.

To determine the progress of the data transfer, the host can either monitor the device's R/B# signal or, execute the READ STATUS REGISTER (70h) command. When the device completes an ERASE Block operation, the host must check the status of the PES2 bit for erase completion status.

Figure 25: Erase Block Operation

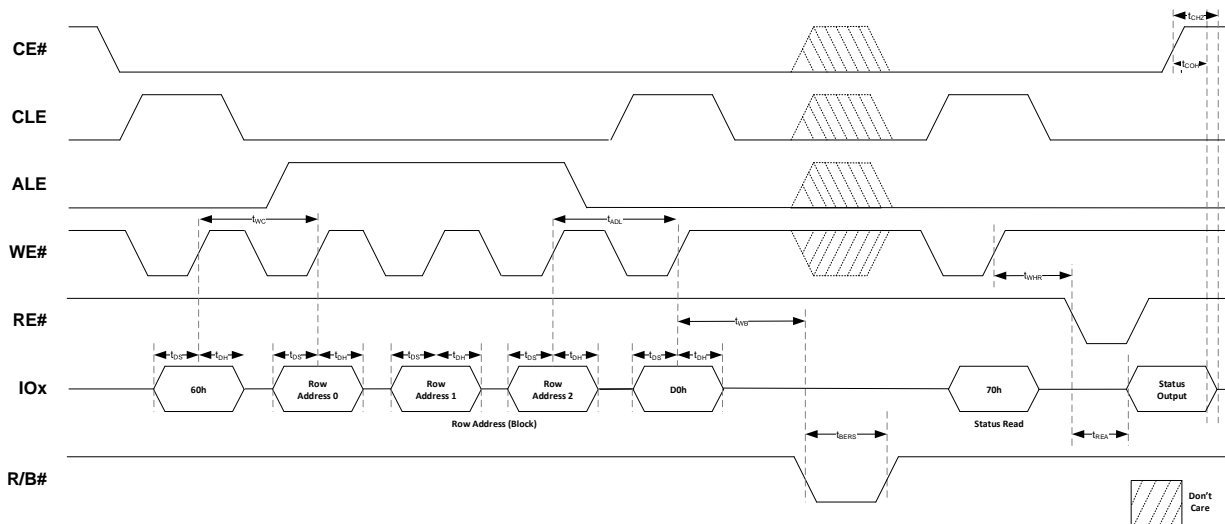

### READ FOR DATA MOVE Operation (00h – 35h)

The READ FOR DATA MOVE (00h-35h) operation working in conjunction with PROGRAM FOR DATA MOVE (85h-10h) operation provides a very efficient copy-back operation where data stored in one page can be written to another page without utilizing any of the host’s resources. It is much faster since loading of the data is not required (if data modifications are not needed).

The READ FOR DATA MOVE (00h-35h) command is functionally identical to the READ PAGE (00h-30h) command, except that 35h is written to the command register instead of 30h.

It is recommended that the host read the data out of the device to verify the data prior to issuing the PROGRAM FOR DATA MOVE (85h-10h) command to prevent the propagation of data errors.

### PROGRAM FOR DATA MOVE Operation (85h – 10h)

The PROGRAM FOR DATA MOVE (85h-10h) command is functionally identical to the PROGRAM PAGE (80h-10h) command, except that when 85h is written to the command register.

Figure 26: Read/Program For Move Operation

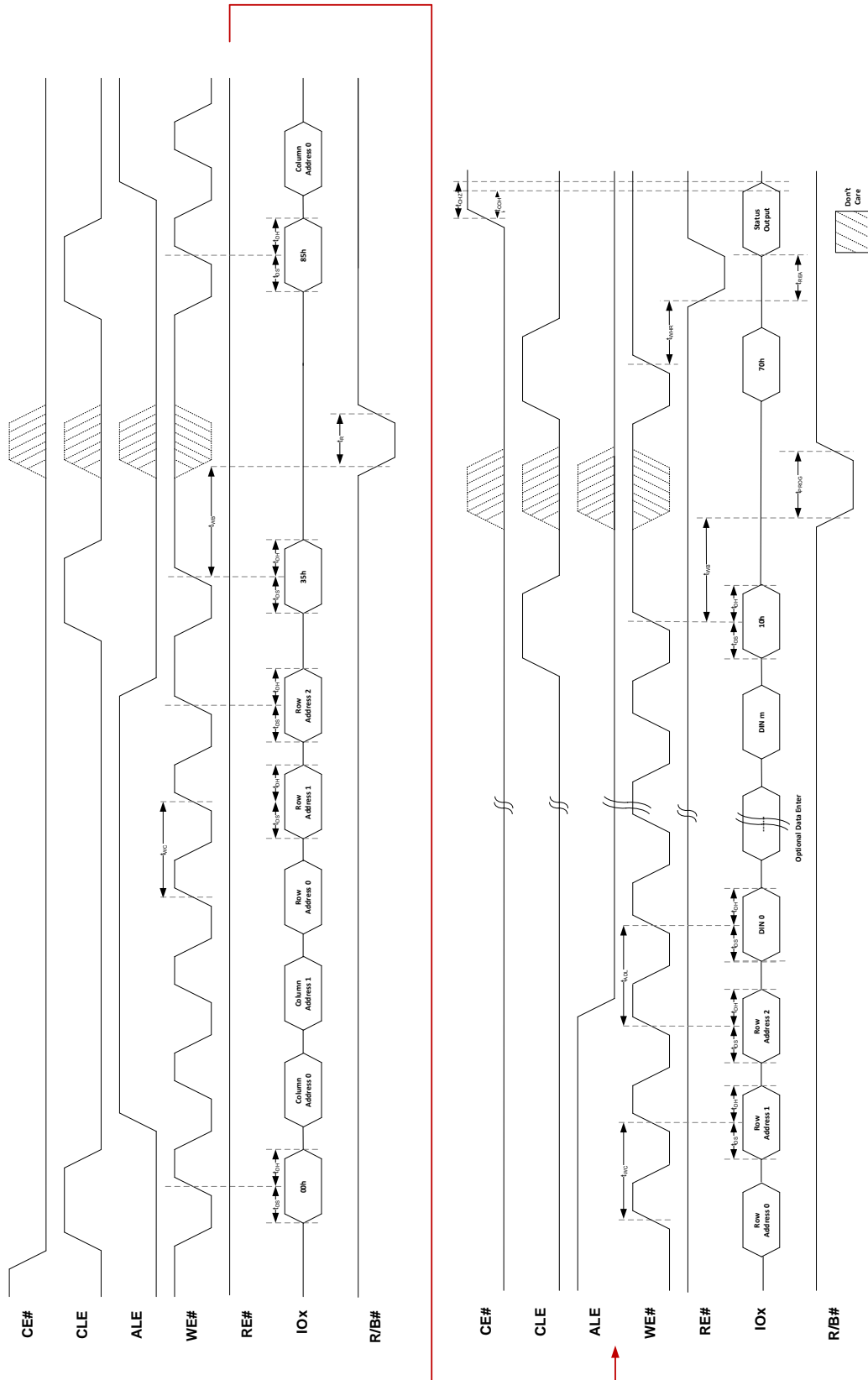
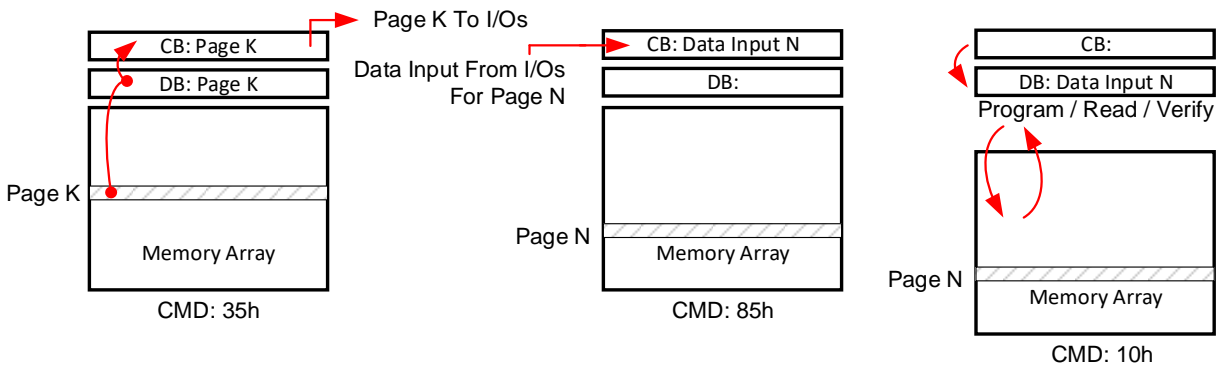

Figure 27: Read/Program For Data Move Operation Overview



Data Move operation from Page K to Page N is as following:

- 1 Data for Page K is transferred to the Cache Buffer (CB)- Read for Data Move.
- 2 Data for Page K is read out.
- 3 Data Move to Page address N is input and any data updates are implemented.
- 4 CB for Page N is transferred to the Data Buffer (DB).
- 5 By issuing the 10h command, the data in the DB is programmed to Page N– Program for Data Move

### ONE-TIME PROGRAMMABLE (OTP) ENTRY Operation (29h-17h-04h-19h)

The device contains a one-time programmable (OTP) area, which is accessed by writing 29h-17h-04h-19h to the command register. The device is then ready to accept READ PAGE (00h-30h) and PROGRAM PAGE (80h-10h) commands. The OTP area is of a single block size (64 pages), and hence only row addresses between 00h and 3Fh are allowed. The host must issue the Reset command to exit the OTP area and access the normal flash array. The ERASE BLOCK (60h-D0h) command is not allowed in the OTP area.

### MULTI-PLANE Operations

Axia's 2Gbit NAND Flash devices are divided into two physical planes. Each plane contains a cache register and a data register independent of the other plane. The planes are addressed via the lowest block address bit (BA[6]). Specific details are provided in array addressing sequence.

Two-plane operations must be of the same type across the planes; for example, it is not possible to perform a PROGRAM operation on one plane with an ERASE operation on another.

When issuing a two-plane program or erase operation, use the READ STATUS (70h) command and check the status of the previous operation(s); pass or fail. If the READ STATUS (70h) command indicates that an error occurred (PS1 = 1 and/or PES2 = 1), use the READ STATUS MULTI-PLANE (78h) command to determine which plane's operation failed.

### MULTI-PLANE Operations' Addressing Requirements

Multi-plane commands for 2Gbit devices require two, five-cycle addresses; one address per plane. For a given multi-plane operation, these addresses are subject to the following requirements:

- The plane select bit, BA[6], must be different for each issued address.
- The page address bits, PA[5:0], must be identical for each issued address.
- The READ STATUS REGISTER Multi-Plane / Multi-Device (78h) command can be used following multi-plane program page and erase block operations to check the status.

## PROGRAM PAGE MP Operation

### (80h – 11h – 81h – 10h) / (80h – 11h – 80h – 10h)

The PROGRAM PAGE MP (80h-11h-81h/80h-10h) command enables the host to program two pages in parallel (one in each plane). A multi-plane program cycle consists of a double serial data loading period in which up to 4352 bytes of data can be loaded into the data register, followed by a non-volatile programming period where the loaded data is programmed into the appropriate cells. Two command sequences are shown which realize the same operation.

To input a page to the cache register and queue it to be moved to the NAND Flash array at the specified address, write 80h to the command register followed by five address cycles containing the column address and row address. Data input cycles follow where serial data is input beginning at the specified address. At any time during the data input cycle, the RANDOM DATA INPUT (85h) command can be issued. When data input is complete, write 11h to the command register. The device will go busy (RDY = 0, ARDY = 0) for  $t_{\text{PBSY}}$ .

To determine the progress of  $t_{\text{PBSY}}$ , the host can monitor the device's R/B# signal or, issue the READ STATUS REGISTER operations (70h, 78h). When the device's status shows that it is ready (RDY = 1), additional PROGRAM PAGE MP (80h-11h) commands can be issued to queue additional planes for data transfer. Alternatively, the PROGRAM PAGE (80h-10h) or PROGRAM PAGE CACHE (80h-15h) commands can be issued.

When the PROGRAM PAGE (80h-10h) command is used as the final command of a multi-plane program operation, data is transferred from the cache registers to the NAND Flash array for all addressed planes during  $t_{\text{PROG}}$ . When the device is ready (RDY = 1, ARDY = 1), the host should check the status of the PS1/PES2 bits for each of the planes to verify that programming was successfully.

Note that all commands are prohibited between 11h and 81h/80h except for READ STATUS REGISTER / READ STATUS REGISTER MP/MD and RESET commands.

Note that the PROGRAM PAGE MP command is available only within two paired blocks in separate planes. This is accomplished in two ways:

1. (80h – 11h – 81h – 10h) - By setting the block address bits for the first plane to all zeros and the second address issued selects the block for both planes (plane address bit must be '1' in the second address issued).
2. (80h – 11h – 80h – 10h) - Both addresses are issued in this protocol, however, the block address bits must be the same except for the bit(s) that select the planes.

Figure 28: Program Page MP Operation

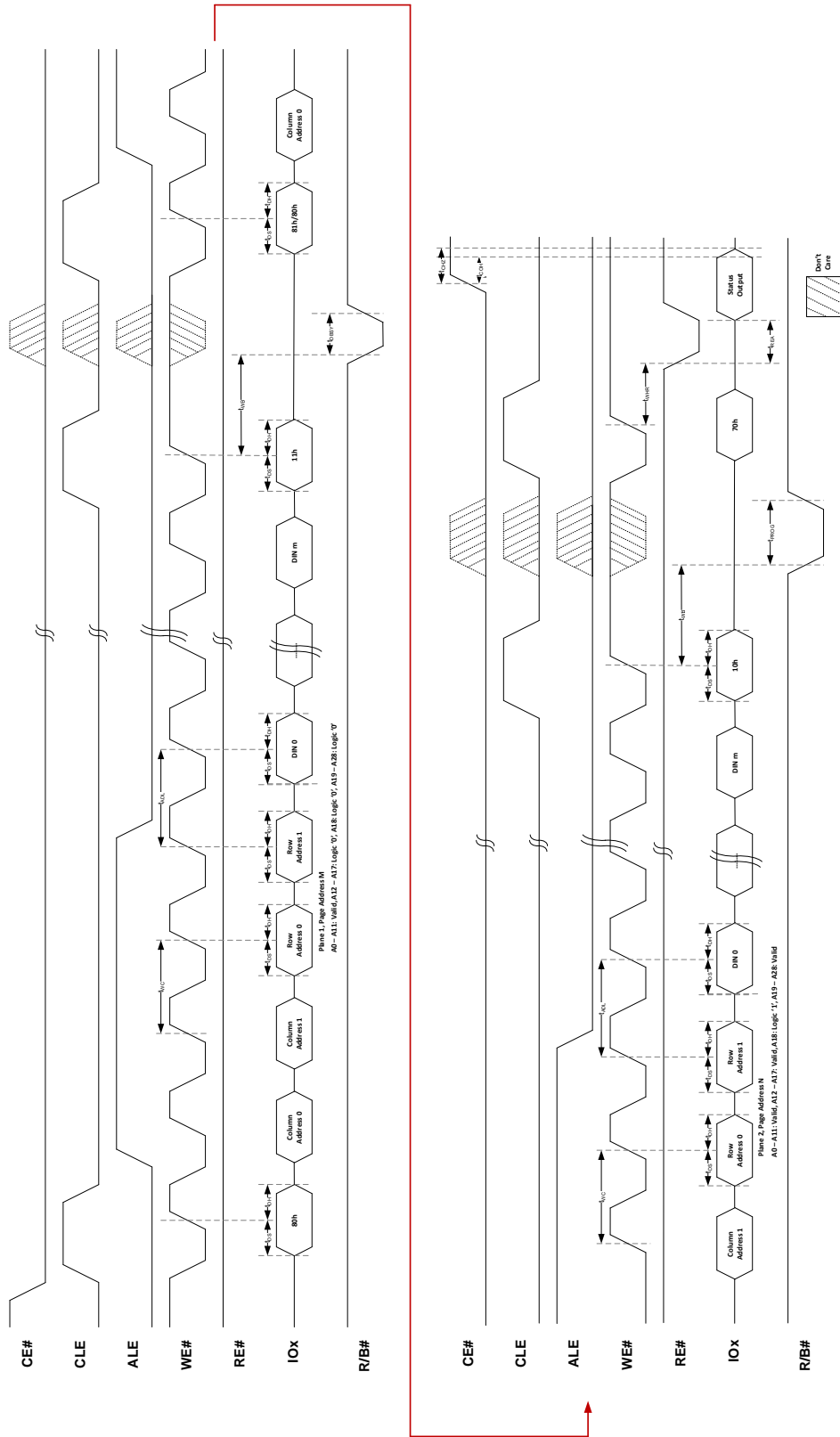
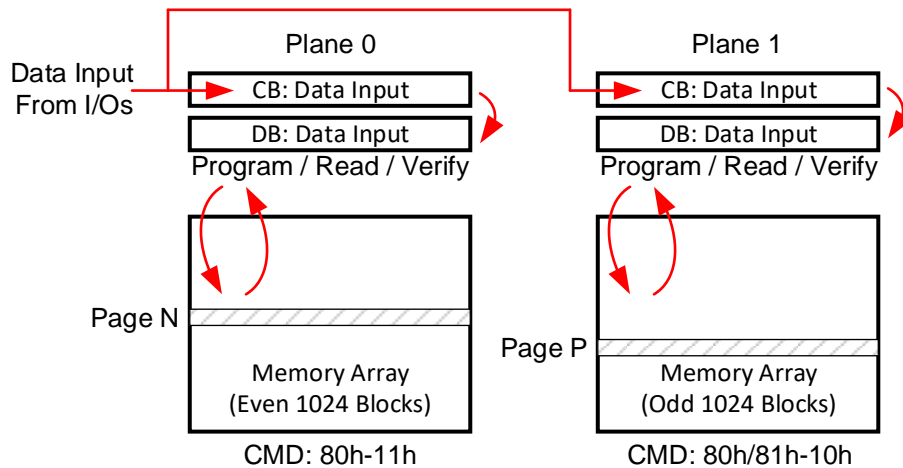

Figure 29: Program Page MP Operation Overview



The data is programmed from the DBs to the selected pages in the two planes on the rising edge of WE# following input of the "10h" command. After programming, the programmed data is transferred back to the DBs to be automatically verified by the device. If the programming does not succeed, the Program/Verify operation is repeated by the device until success is achieved or until the maximum programming loop count is reached.

## PROGRAM PAGE CACHE MP Operation

### (80h – 11h – 81h – 15h) / (80h – 11h – 80h – 15h)

The PROGRAM PAGE MP (80h-11h) command moves multiple pages from the cache registers to the data registers and on to different planes of the NAND Flash array. Once the programming data is moved from the cache registers, they are free to receive data input from the host. This is done by appending PROGRAM PAGE CACHE MP (81h/80h-15h) command to the PROGRAM PAGE MP (80h-11h) command.

When the PROGRAM PAGE CACHE MP (81h/80h-15h) command is used as the final command of a program cache multi-plane operation, data is transferred from the cache registers to the data registers. The data is then moved from the data registers to the NAND Flash array for all addressed planes. This occurs during  $t_{\text{PBSY}}$ . After  $t_{\text{PBSY}}$ , the host should check the status of the PS1 bit for each of the planes from the program cache operation to verify that programming completed successfully.

Note that all commands are prohibited between 11h and 81h/80h except for READ STATUS REGISTER / READ STATUS REGISTER MP/MD and RESET commands.

Note that the PROGRAM PAGE CACHE MP command is available only within two paired blocks in separate planes. This is accomplished in two ways:

1. (80h – 11h – 81h – 15h) - By setting the block address bits for the first plane to all zeros and the second address issued selects the block for both planes (plane address bit must be '1' in the second address issued).
2. (80h – 11h – 80h – 15h) - Both addresses are issued in this protocol, however, the block address bits must be the same except for the bit(s) that select the planes.

Figure 30: Program Page Cache MP Operation

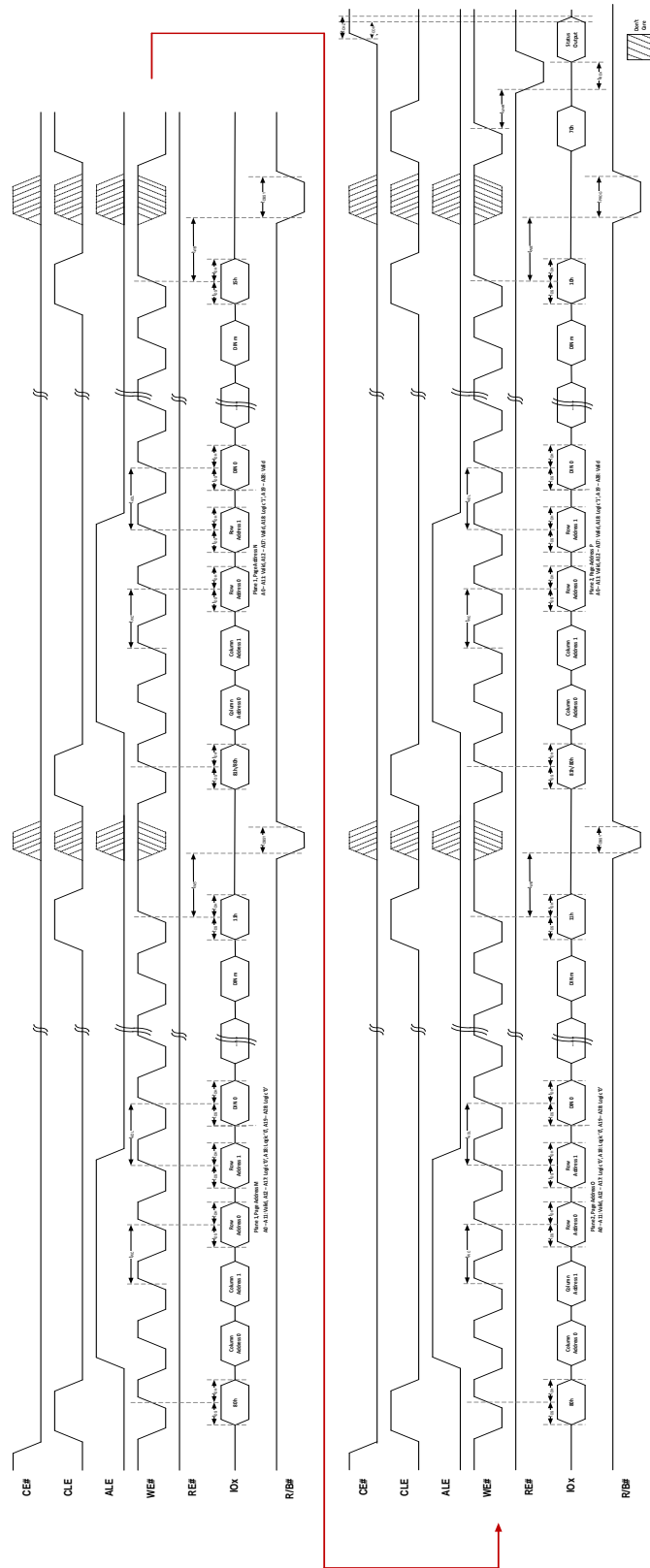

## ERASE BLOCK MP Operation

### (60h – 60h – D0h) / (60h – D1h – 60h – D0h)

The ERASE BLOCK MP (60h-D1h or 60h) command queues a plane addressed block to be erased in the NAND Flash array. This command can be issued one or more times. Each time a new plane address is specified, that block in the plane is queued to be erased. To specify the final block to be erased and to begin the ERASE operation for all previously queued planes, issue the ERASE BLOCK (60h-D0h) command. This command is accepted by the device when it is ready (RDY = 1, ARDY = 1).

To queue a block to be erased, write 60h to the command register, then write three address cycles containing the row address; the page address is ignored. Conclude by writing D1h to the command register. The device will go busy (RDY = 0, ARDY = 0) for  $t_{EBSY}$ . Note that if D1h is omitted, the device will not go busy for  $t_{EBSY}$ .

To determine the progress of  $t_{EBSY}$ , the host can monitor the device's R/B# signal, or alternatively, the READ STATUS REGISTER operations (70h, 78h) can be used. When the device's status shows that it is ready (RDY = 1, ARDY = 1), additional ERASE BLOCK MP (60h-D1h) commands can be issued to queue additional planes for erase. Alternatively, the ERASE BLOCK (60h-D0h) command can be issued to erase all queued blocks.

Note that all commands are prohibited between 11h and 81h/80h except for READ STATUS REGISTER / READ STATUS REGISTER MP/MD and RESET commands.

Note that the ERASE BLOCK MP command is available only within two paired blocks in separate planes. This is accomplished in two ways:

1. (60h – 60h – D0h) - By setting the block address bits for the first plane to all zeros and the second address issued selects the block for both planes (plane address bit must be '1' in the second address issued).
2. (60h – D1h – 60h – D0h) - Both addresses are issued in this protocol, however, the block address bits must be the same except for the bit(s) that select the planes.



Figure 31: Erase Block MP Operation

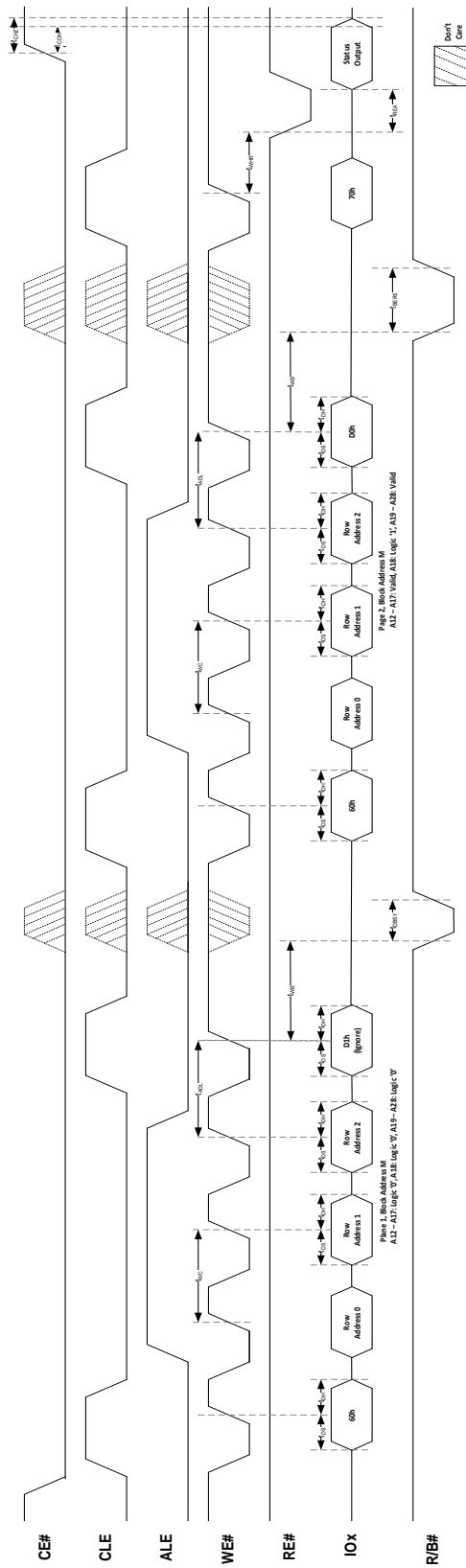

---

**PROGRAM FOR DATA MOVE MP Operation****(85h – 11h - 81h – 10h) / (85h – 11h – 85h – 10h)**

The PROGRAM FOR DATA MOVE MP (85h-11h) command is functionally identical to the PROGRAM PAGE MP(85h-11h) command. Program for multi-plane data move program must be preceded by 2 single READ FOR DATA MOVE (00h-35h) (1<sup>st</sup> page must be read from the 1<sup>st</sup> plane and 2<sup>nd</sup> page from the 2<sup>nd</sup> plane). Multi-plane copy back cannot cross plane boundaries: the contents of the source page of one plane can only be copied to a destination page in the same plane.

Note that all commands are prohibited between 11h and 81h/80h except for READ STATUS REGISTER / READ STATUS REGISTER MP/MD and RESET commands.

Note that the PROGRAM FOR DATA MOVE MP command is available only within two paired blocks in separate planes. This is accomplished in two ways:

1. (85h – 11h – 81h – 10h) - By setting the block address bits for the first plane to all zeros and the second address issued selects the block for both planes (plane address bit must be '1' in the second address issued).
2. (85h – 11h – 85h – 10h) - Both addresses are issued in this protocol, however, the block address bits must be the same except for the bit(s) that select the planes.

Figure 32: Program for Data Move MP Operation

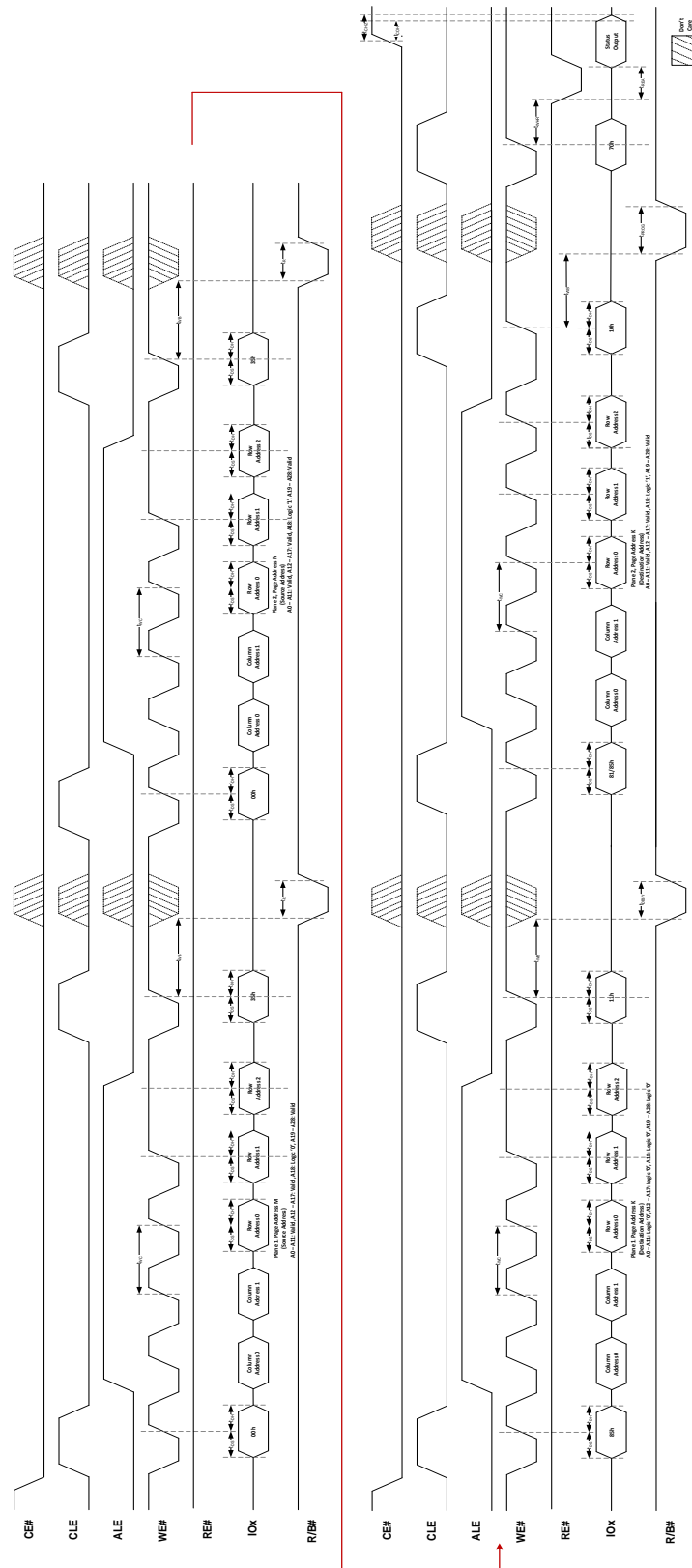

### READ STATUS REGISTER MP / MD Operation (78h)

The READ STATUS REGISTER MP/MD (78h) command returns the status value on a specific plane in case of multi-plane operation on the same die or the status value in a specific die in multi-die packages.

Writing 78h to the command register, followed by three row address cycles containing the page, block, and device addresses, puts the selected device into read status mode. The selected device stays in this mode until another valid command is issued. Devices that are not addressed are deselected to avoid bus contention.

Figure 33: Read Status Register MP / MD Operation

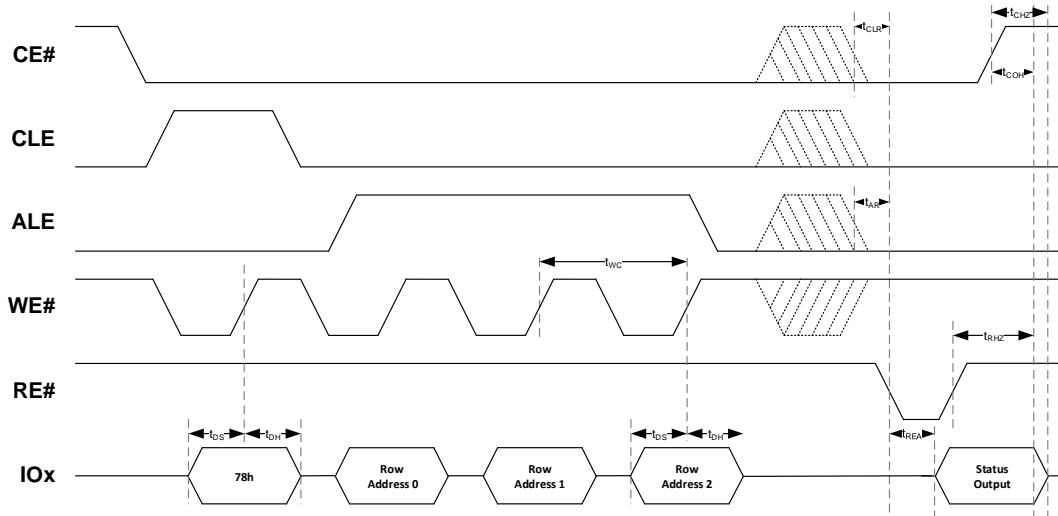

## Device Initialization

When powering up, the following procedure is required to initialize the device correctly:

- Ramp  $V_{CC}$ .
- Drive  $WP\#$  Low during power-up until  $V_{CC}$  is stable
- RESET operation is required after  $V_{CC}$  ramps up and must be the first command issued. The host must wait 5ms after  $V_{CC}$  reaches  $V_{CC}$  (minimum) before issuing RESET.
- The device is now initialized and ready for normal operation (after RESET busy time  $t_{RST}$  has elapsed - this can be monitored by polling  $R/B\#$  or issuing the READ STATUS (70h) command).

Figure 34: Power-On Behavior

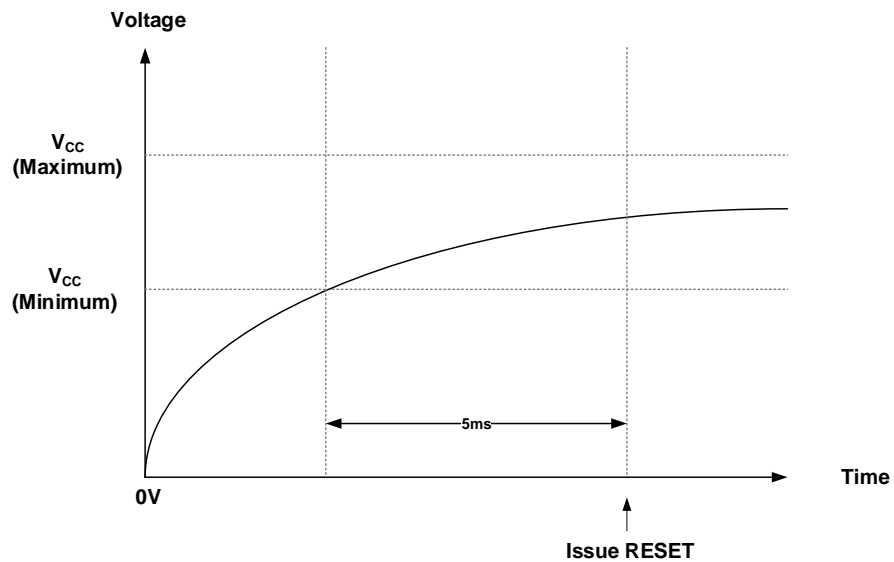
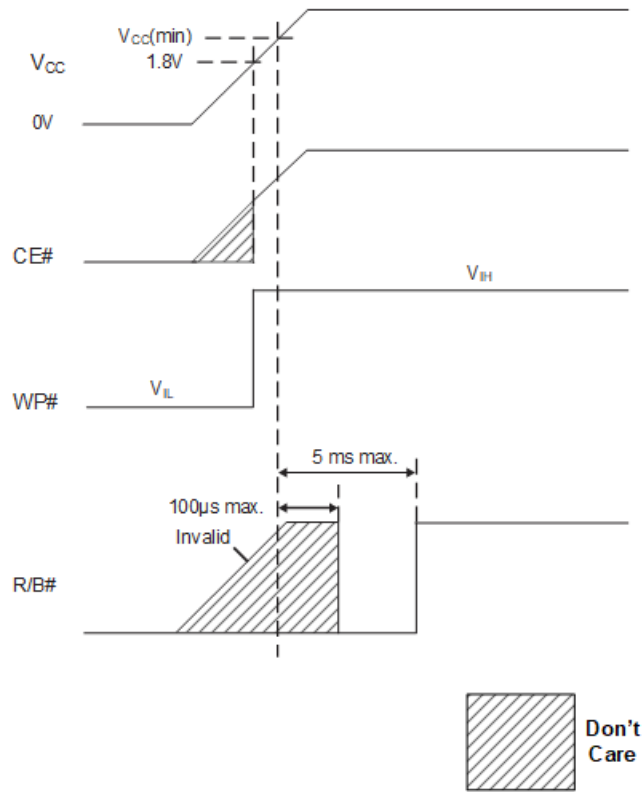

Figure 35: Power-On Behavior (Continued)



## Device Power-Down

When powering down, the following procedure is required to initialize the device correctly:

- Ramp down  $V_{CC}$ .
- Drive WP# Low during power-down before  $V_{CC}$  reaches  $V_{CC}$  (minimum) and goes below.

Figure 36: Power-Down Behavior

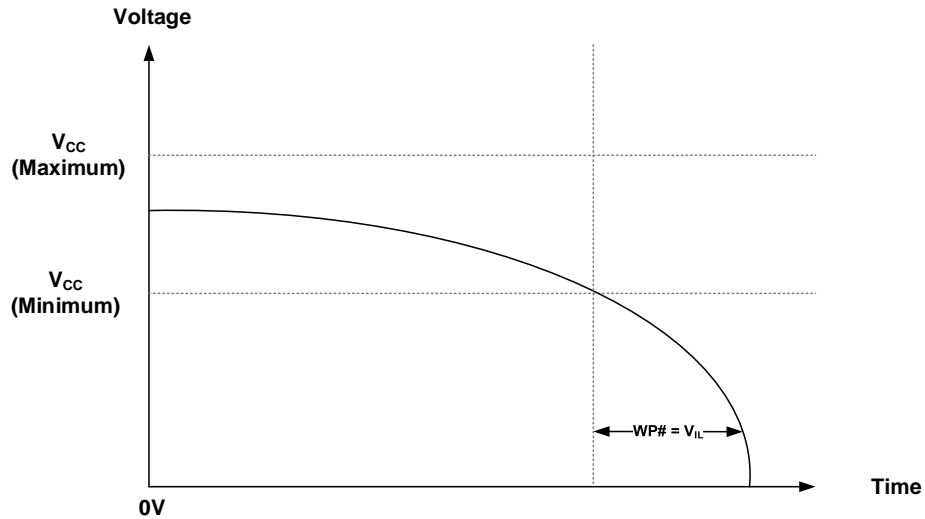
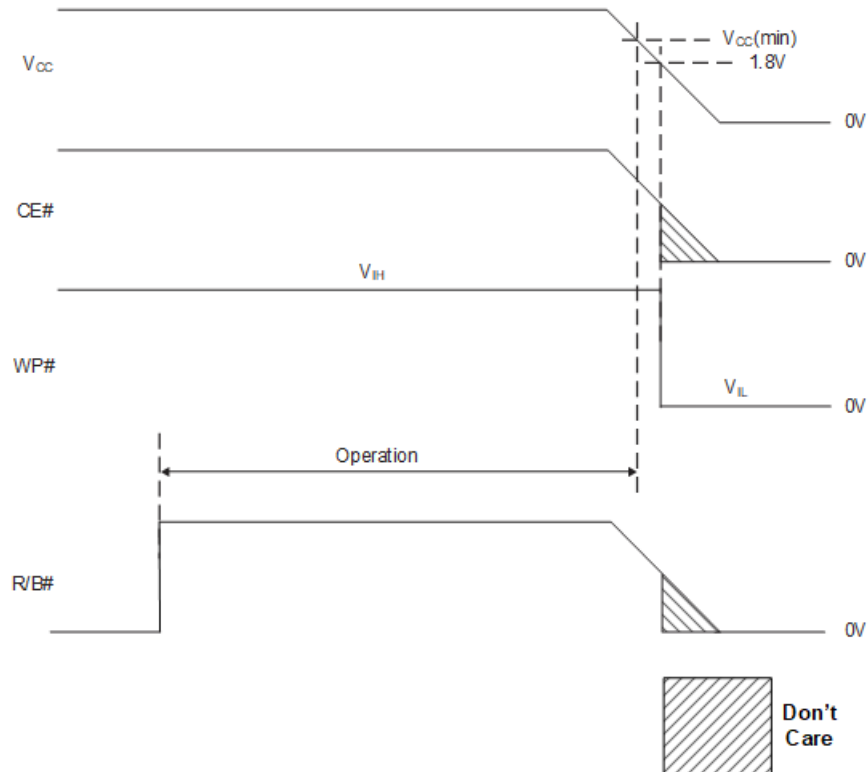

Figure 37: Power-Down Behavior (Continued)



## Electrical Specifications

Table 15: Absolute Maximum Ratings

Voltage on any pin with respect to V <sub>SS</sub>			
Parameter / Condition	Minimum	Maximum	Units
Voltage Input	-0.6	4.6	V
V <sub>CC</sub> Supply Voltage	-0.6	4.6	V
Storage Temperature	-65.0	150.0	°C
Short circuit output current, I/Os	-	5.0	mA

Table 16: Recommended Operating Conditions

Parameter / Condition	Minimum	Maximum	Units	
Operating Temperature	Industrial	-40.0	85.0	°C
V <sub>CC</sub> Supply Voltage	3.0V	2.7	3.6	V
V <sub>SS</sub> Supply Voltage	0V	0.0	0.0	V

Table 17: Pin Capacitance

Parameter	Test Conditions	Symbol	Maximum	Units
Input Pin Capacitance	TEMP = 25°C; f = 1 MHz; V <sub>IN</sub> = 0V	C <sub>IN</sub>	10.0	pF
Input / Output Pin Capacitance	TEMP = 25°C; f = 1 MHz; V <sub>IN</sub> = 0V	C <sub>INOUT</sub>	10.0	pF

Table 18: DC Characteristics

Parameter	Symbol	Test Conditions	3.0V Device (2.7V-3.6V)			Units
			Minimum	Typical	Maximum	
Read Current (Seq)	I <sub>CC1</sub>	t <sub>RC</sub> = 50ns, CE#=V <sub>IL</sub> , I <sub>OUT</sub> =0mA	-	15.0	30.0	mA
Program Current	I <sub>CC2</sub>		-	15.0	30.0	mA
Erase Current	I <sub>CC3</sub>		-	15.0	30.0	mA
Standby Current (TTL)	I <sub>CC4</sub>	CE#=V <sub>IH</sub> , WP#=0V/V <sub>CC</sub>	-	-	1.0	mA
Standby Current (CMOS)	I <sub>CC5</sub>	CE#=V <sub>CC</sub> -0.2, WP#=0V <sub>CC</sub>	-	10.0	50.0	µA
Input Leakage Current	I <sub>LI</sub>	V <sub>IN</sub> =0 to V <sub>CC</sub> (max)	-	-	±10.0	µA
Output Leakage Current	I <sub>LO</sub>	V <sub>OUT</sub> =0 to V <sub>CC</sub> (max)	-	-	±10.0	µA
Input High Voltage	V <sub>IH</sub>		0.8xV <sub>CC</sub>	-	V <sub>CC</sub> +0.3	V
Input Low Voltage	V <sub>IL</sub>		-0.3	-	0.2xV <sub>CC</sub>	V
Output High Voltage Level	V <sub>OH</sub>	I <sub>OH</sub> = -100µA	V <sub>CC</sub> -0.1	-	-	V
		I <sub>OH</sub> = -400µA	2.4	-	-	V
Output Low Voltage Level	V <sub>OL</sub>	I <sub>OL</sub> = 100mA	-	-	0.1	V
		I <sub>OL</sub> = 2.1mA	-	-	0.4	V
Output Low Current (R/B#)	I <sub>OL</sub> (R/B#)	V <sub>OL</sub> =0.1V	3.0	4.0	-	mA
		V <sub>OL</sub> =0.4V	8.0	10.0	-	mA



Table 19: Program / Erase Characteristics

Parameter	Symbol	3.0V Device (2.7V-3.6V)			Units
		Minimum	Typical	Maximum	
Program Time	t <sub>PROG</sub>	-	300.0	700.0	μs
Cache Program Time	t <sub>PBSY</sub>	-	3.0	t <sub>PROG</sub>	μs
Cache Erase Time	t <sub>EBSY</sub>	-	0.5	1.0	μs
Block Erase Time	t <sub>BERS</sub>	-	3.5	10.0	ms
Array Read Time	t <sub>R</sub>	-	-	30.0	μs
Cache Read Time	t <sub>RBSY</sub>	-	3.0	t <sub>R</sub>	μs
Number of Partial-Page Programs	NOP	-	-	4.0	cycles

Table 20: AC Test Conditions

Parameter	Value
Input pulse levels	0.0V to V <sub>CC</sub>
Input rise and fall times	5ns
Input and output measurement timing levels	V <sub>CC</sub> /2
Output Load	CL = 30pF

Table 21: AC Timing Characteristics

Parameter	Symbol	3.0V Device (2.7V-3.6V)		Units
		Minimum	Maximum	
CLE Setup time	t <sub>CLS</sub>	12.0	-	ns
CLE Hold time	t <sub>CLH</sub>	5.0	-	ns
CE# Setup time	t <sub>CS</sub>	20.0	-	ns
CE# Hold time	t <sub>CH</sub>	5.0	-	ns
WE# Pulse width	t <sub>WP</sub>	12.0	-	ns
ALE Setup time	t <sub>ALS</sub>	12.0	-	ns
ALE Hold time	t <sub>ALH</sub>	5.0	-	ns
Data Setup time	t <sub>DS</sub>	12.0	-	ns
Data Hold time	t <sub>DH</sub>	5.0	-	ns
Write Cycle time	t <sub>WC</sub>	25.0	-	ns
WE# High Hold time	t <sub>WH</sub>	10.0	-	ns
Address to Data Loading time	t <sub>ADL</sub>	70.0	-	ns
Data Transfer from Cell to Register	t <sub>R</sub>	-	30.0	μs
ALE to RE# Delay	t <sub>AR</sub>	10.0	-	ns
CLE to RE# Delay	t <sub>CLR</sub>	10.0	-	ns
Ready to RE# Low	t <sub>RR</sub>	20.0	-	ns
RE# Pulse Width	t <sub>RP</sub>	12.0	-	ns



2Gbit x8, x16: NAND Flash Memory

Parameter	Symbol	3.0V Device (2.7V-3.6V)		Units
		Minimum	Maximum	
WE# High to Busy	t <sub>WB</sub>	-	100.0	ns
Read Cycle Time	t <sub>RC</sub>	25.0	-	ns
RE# Access Time	t <sub>REA</sub>	-	20.0	ns
CE# Access Time	t <sub>CEA</sub>	-	25.0	ns
RE# High to Output Hi-Z	t <sub>RHZ</sub>	-	100.0	ns
CE# High to Output Hi-Z	t <sub>CHZ</sub>	-	30.0	ns
CE# High to ALE or CLE Don't care	t <sub>CSD</sub>	10.0	-	ns
RE# High to Output Hold	t <sub>RHOH</sub>	15.0	-	ns
RE# Low to Output Hold	t <sub>RLOH</sub>	5.0	-	ns
CE# High to Output Hold	t <sub>COH</sub>	15.0	-	ns
RE# High Hold Time	t <sub>REH</sub>	10.0	-	ns
Output Hi-Z to RE# Low	t <sub>IR</sub>	0.0	-	ns
RE# High to WE# Low	t <sub>RHW</sub>	100.0	-	ns
WE# High to RE# Low	t <sub>WHR</sub>	60.	-	ns
Device Resetting Time (Read/Program/Erase)	t <sub>RST</sub>	-	5.0/10.0/500.0	μs
Write protection time	t <sub>WW</sub>	100.0	-	ns

## Error Management

NAND Flash devices have bad blocks that are invalid when shipped from the factory. However, each NAND Flash device specifies a minimum number of valid blocks (NVB) of the total available blocks during the endurance life of the product. An invalid block is one that contains at least one page that has more bad bits than can be corrected by the minimum required ECC. Even though NAND Flash devices contain bad blocks, they can be used reliably in systems provided the systems have bad block management and error-correction algorithms.

Axia’s NAND Flash devices are shipped from the factory erased. The factory identifies invalid blocks before shipping by providing a bad block marker (00h to FEh) into the 1st byte in the spare area of the 1st or 2nd page (if the 1st page is Bad). This method is compliant with ONFI Factory Defect Mapping requirements.

System software should check the first spare area location on the first page of each block before performing any PROGRAM or ERASE operations on the NAND Flash device, thus creating a bad block table for the whole device.

The following recommendations should be followed to achieve maximum reliability performance:

- Always check the program/erase status bits (PS1, PES2) after a PROGRAM or ERASE operation
- Use bad block management and wear-leveling algorithms
- The first block (physical block address 00h) is guaranteed to be valid with ECC when shipped from the factory (1K program/erase cycles)

*Table 22: Error Management Details*

Description	Requirement
<b>Minimum number of valid blocks (NVM)</b>	2008
<b>Total number of available blocks</b>	2048
<b>First spare area location</b>	x8: byte 2048, x16: word 1024
<b>Bad block mark</b>	x8: 00h - FEh, x16: 0000h - FFFEh

## ECC Management

Digital data stored in SLC NAND Flash is prone to a certain number of errors which must be detected and corrected. Error correction codes (ECC) are widely implemented on the host side which encode data in such a way that a decoder can identify and correct errors in the data.

The most commonly used ECC codes in the industry are Hamming, Reed-Solomon and Bose-Chaudhuri-Hocquenghem (BCH).

Hamming codes are designed to detect 2-bit errors and correct 1-bit errors. As an example, according to the Hamming ECC principle, a 22-bit ECC syndrome is needed to perform a 1-bit correction per 256 bytes. Similarly, for 512 bytes, a Hamming ECC principle can be used that generates a 24-bit ECC syndrome per 528 bytes to perform a 2-bit detection and a 1-bit correction. Thus, for 2112-byte page NAND devices, the calculation is done per 512 bytes; a 24-bit ECC syndrome per 512 bytes (exactly 3 bytes per 512 bytes). 2112-byte pages are divided into 512-byte (main area page) + 32-byte (spare) chunks. Figure 38 shows how the main and spare page areas can be used to implement the Hamming codes.

Figure 38: Main Page divided into Chunks

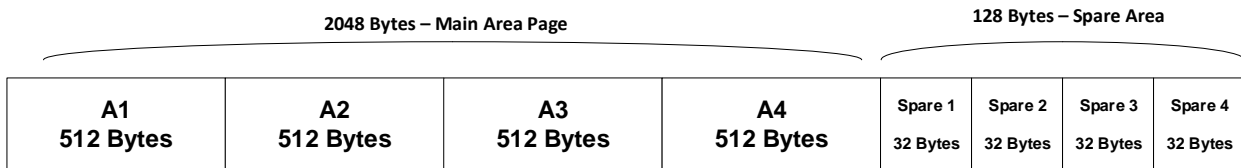

BCH codes are more popular than Reed-Solomon due to their improved efficiency. However, BCH can only correct 1-bit errors which are more typical in NAND Flash devices. Most new processor designs anticipate coupling with NAND Flash devices and include 4-bit and greater ECC engines within the hardware itself. Axia’s recommendation for BCH based ECC is shown in Table 23:

Table 23: Minimum ECC Requirements

Description	Requirement
<b>Minimum required ECC</b>	4-bit ECC per 528 bytes of data

## Product Use Limitations

Axia reserves the right to make changes to the information in this document, and related hardware, software and system (collectively referred to as “**Products**”) without notice. This document supersedes and replaces any and all prior or contemporaneous information or arrangement of any kind relating to the subject matter hereof. This document and any information set forth herein may not be reproduced without the prior written permission from Axia.

**Critical Applications.** Products are not authorized for use in applications in which failure of the Axia component could result, directly or indirectly in death, personal injury, or severe property or environmental damage (“**Critical Applications**”). Axia assumes no liability for Products if used for Critical Applications. Should customer or distributor purchase, use, or sell any Axia component for Critical Applications, customer and distributor shall indemnify and hold harmless Axia and its subsidiaries, subcontractors, and affiliates and the directors, officers, and employees of each against all claims, costs, damages, and expenses and reasonable attorneys' fees arising out of, directly or indirectly, any claim of product liability, personal injury, or death arising in any way out of such Critical Application, whether or not Axia or its subsidiaries, subcontractors, or affiliates were negligent in the design, manufacture, or warning of the Products.

**Automotive Applications.** Products are not authorized for use in automotive applications unless specified by Axia. Axia assumes no liability for Products if used for automotive applications. Distributor and customer shall assume the sole risk and liability for such use and shall indemnify and hold Axia harmless against all claims, costs, damages, and expenses and reasonable attorneys' fees arising out of, directly or indirectly, any claim of product liability, personal injury, death, or property damage resulting directly or indirectly from any use of Products in automotive applications.

**Military Applications.** Products are not authorized for use in military applications, including without limitation, for the design, development, use, stockpiling or manufacturing of nuclear, chemical, or biological weapons or missile technology products (mass destruction weapons).

**Customer Responsibility.** Customers are solely responsible for the design and operation of their systems using Products. It is customer’s sole responsibility to determine whether Products are suited for their system. Customers are required to incorporate good safety design measures and adequate safeguards to eliminate risks of personal injury, death, or severe property or environmental damages that could result from failure of Products. **AXIA ASSUMES NO LIABILITY FOR CUSTOMERS' PRODUCT DESIGN OR APPLICATIONS AND DAMAGES OR LOSSES OCCURRING AS A RESULT OF NONCOMPLIANCE WITH APPLICABLE LAWS AND REGULATIONS.**

The information contained herein is presented only as guidance for Product use. Axia assumes no responsibility for any infringement of patents or any other intellectual property rights of third parties that may result from the use of Products. No license to any intellectual property right is granted by this document, whether expressed or implied. You may not perform compositional, structural, functional or other analysis of Products, or undertake deconvolution or reverse engineering with respect to Products.

### **Limited Warranty**

In no event shall Axia and its representatives be liable for any indirect, incidental, punitive, special or consequential damages (including but not limited to loss of use, revenue or profit), whether or not such damages are based on tort, warranty, breach of contract or other legal theory.

In no event shall Axia’s aggregate liability for any breach, warranty, indemnity or other obligation or liability arising out of or in connection with the sale of Products or the use of any Products exceed the purchase price of the particular Product(s) or services with respect to which losses or damages are claimed.



## Revision History

Revision	Date	Change Summary
REV E	10/10/2018	Initial release
REV F	04/14/2019	Added Typ. to Endurance Updated Array Read Time ( $t_R$ ), Figure 35: Power-On Behavior (Continued), Figure 37: Power-Down Behavior (Continued)