

5.5V Miniaturized Low Resistance Capacitors

GREEN CAP 70°C

- Internal resistance was reduced to 85% to DX series and this size.
- 5mm tall. Max. thin profile (H-shaped).
- Miniaturized but can encase up to 0.47F in 11.5×5mm case, and 1.5F in $\phi 19.0 \times 20.5$ mm case.
- It excels in rapid charge.
(It can charge and discharge with 1.5 times as much current (mA) as rated capacitance.)

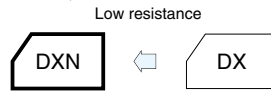

Marking color : White print on an indigo sleeve

Specifications

Item	Performance								
Category temperature range (°C)	-25 to +70								
Tolerance at rated capacitance (%)	-20 to +80								
Internal resistance at 1 kHz	Rated capacitance (F)	0.047	0.1	0.22	0.33	0.47	0.47	1	1.5
	Internal resistance (Ω Max.)	25	25	25	25	25 ($\phi 11.5$)	20 ($\phi 19.0$)	20	20
Characteristics at high and low temperature	Percentage of capacitance change	Within $\pm 30\%$ of the value at 20°C							
	Internal resistance	Less than five times of the value at 20°C							
Endurance (70°C)	Test time	1000 hours							
	Percentage of capacitance change	Within $\pm 30\%$ of the initial measured value							
	Internal resistance	Less than four times of the initial specified value							
Shelf life (70°C)	Test time : 1000 hours ; Same as endurance.								
Applicable standards	Conforms to JIS C5160-1 2009(IEC 62391-1 2006)								

Outline Drawing

Unit : mm

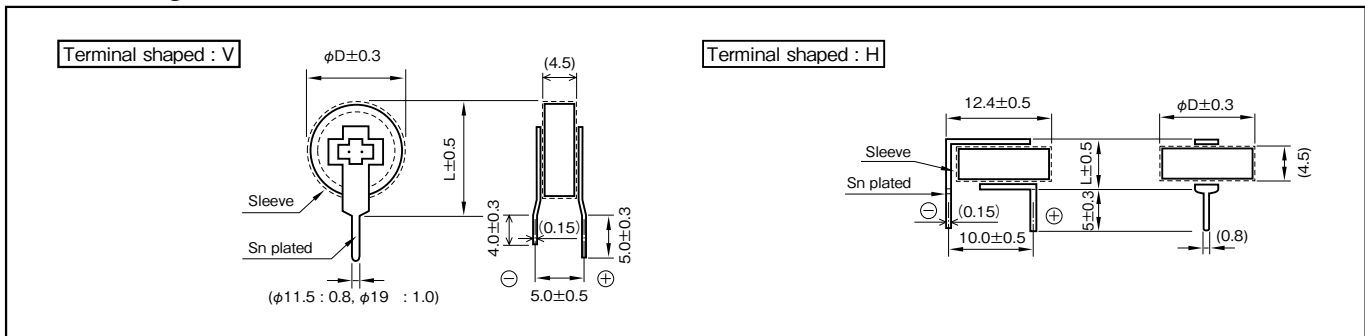

Part numbering system (example : 5.5V0.1F)

DXN	—	5R5	\square	104	\square	U
Series code		Max.operating voltage symbol	Terminal code	Rated Capacitance symbol	Additional symbol	

Part number is refer to following table.

Note

Do not apply external force to products or terminals as stress such as twisting, bending, pushing, or falling of such products or terminals may remove the terminals, resulting in an open/short circuit or liquid leakage. Avoid applying excessive heat to capacitors during heating of an adhesive curing oven. For details, refer to the precautions in use of DYNACAP.

Standard Ratings

Max. operating voltage (V)	Rated capacitance (F)	ELNA Parts No.	$\phi D \times L$ (mm)
5.5	0.047	DXN-5R5V473U	11.5×13.0
		DXN-5R5H473U	11.5× 5.0
5.5	0.1	DXN-5R5V104U	11.5×13.0
		DXN-5R5H104U	11.5× 5.0
5.5	0.22	DXN-5R5V224U	11.5×13.0
		DXN-5R5H224U	11.5× 5.0
5.5	0.33	DXN-5R5V334U	11.5×13.0
		DXN-5R5H334U	11.5× 5.0
5.5	0.47	DXN-5R5V474SU	11.5×13.0
		DXN-5R5H474SU	11.5× 5.0
		DXN-5R5V474U	19.0×20.5
5.5	1	DXN-5R5V105U	19.0×20.5
5.5	1.5	DXN-5R5V155U	19.0×20.5