



XM132 Entry Module

Datasheet v1.4



Abstract

The XM132 Entry Module is a module ready to be evaluated, integrated and used for SW development in commercial products where low power consumption and low system cost is key.

The XM132 Entry Module is built around the Arm® 32-bit Cortex®-M0+ MCU from STMicroelectronics (STM32G071CUB6) and can be used as a stand-alone module where customer can embed their application on top of the Acconeer RSS (Radar System Software). It can also be used with an external host controller where communication to the module is via a register command protocol.

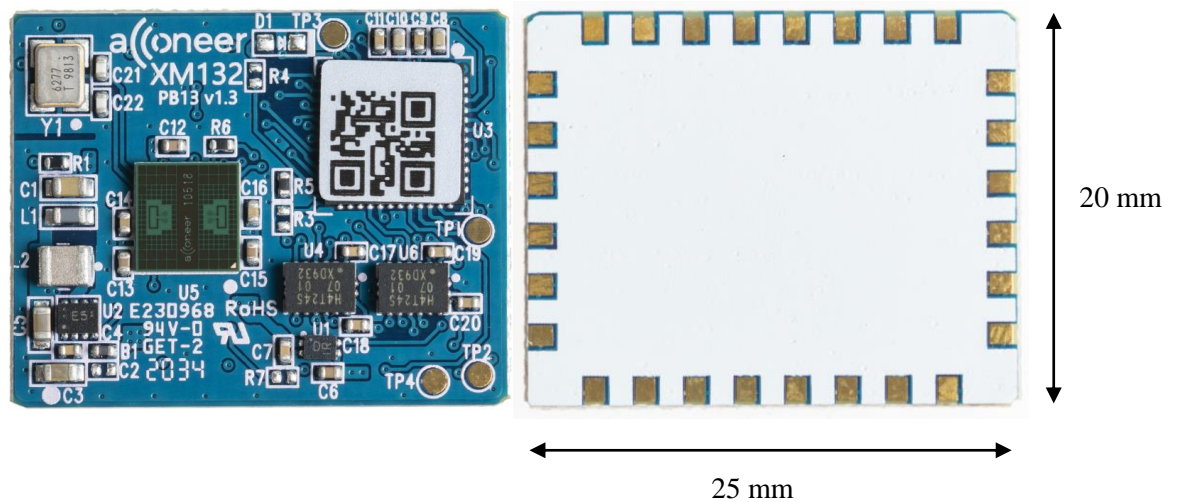

Figure 1. XM132 Top view (left) and XM132 bottom view (right).



Table of Content

1	Revision History	4
2	Functional description	5
2.1	Overview	5
2.2	Product features.....	5
2.3	Block diagram.....	6
2.4	Module board Land Grid Array description.....	7
2.5	Software options	9
3	Interfaces	10
3.1	Module supply input	10
3.2	System functions.....	10
3.3	Serial interfaces	10
3.4	I/O interfaces	10
3.5	Module reset.....	10
4	Electrical specifications	11
4.1	Absolute maximum ratings.....	11
4.2	Recommended operating conditions.....	11
4.3	Power consumption summary	12
4.4	RF specification.....	12
4.5	Typical characteristics, Radar Loop Gain pattern.....	13
5	Reference design description XM132.....	14
5.1	Schematics & BOM	14
5.2	Mechanical specifications and footprint	18
5.3	Moisture Sensitivity Level and Recommended Reflow Profile	19
5.4	RoHS and REACH Statement.....	19
6	Regulatory Approval.....	21
6.1	ETSI.....	21
6.2	FCC.....	22
7	Reference documents	23
8	Abbreviations	24
	Disclaimer	25



1 Revision History

Revision	Comment
v1.0	Released version
v1.1	Added chapter regarding Moisture Sensitivity Level and Recommended Reflow Profile
v1.2	Added chapter 7, Regulatory approval, CE marking
v1.3	Updated chapter 4.4 RF specification. Added chapter 4.5 Typical characteristics, Radar Loop Gain pattern. Added chapter 6.2 FCC.
V1.4	Chapter 5.3 updated.

This document applies to the following product:

Product name	Part number
XM132	XM132

XM132 marking:

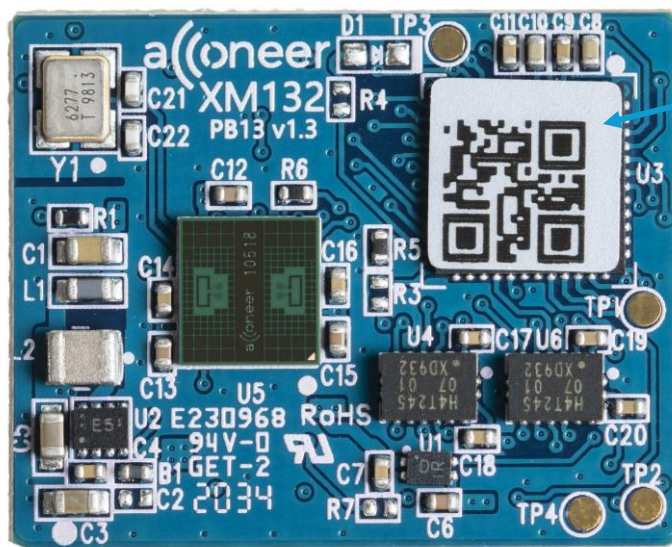

XM132 QR product code & version number



2 Functional description

2.1 Overview

The XM132 Entry Module comes with A111 60GHz PCR sensor with 32-bit ARM® Cortex® M0+ MCU.

Optimized for easy integration with LGA solder pads support, formfactor of 20x25mm and single supply operating voltage 1.8V to 3.6V.

The XM132 Entry Module is delivered with a bootloader enabling customer to download Acconeer RSS software including SDK (Software Development Kit) for stand-alone usage where customer can embed their own application on top of Acconeer RSS software. Acconeer RSS software provides API to set A111 sensor configuration and to retrieve supported radar services and detector data.

XM132 Entry Module offers support as well to act as controlled by external host through register command protocol on UART and I2C.

2.2 Product features

The XM132 Entry Module is based on Acconeer A111 pulsed coherent radar (PCR) and the STMicroelectronics M0+ MCU (STM32G071CUB6).

XM132 Entry Module features:

- A111 60 GHz Pulsed Coherent Radar (PCR) with integrated baseband, RF front-end and Antenna in Package (AiP)
- 32-bit ARM® Cortex® M0+ MCU (STM32G071CUB6) 64 MHz clk speed, 128 kB Flash; 36kB RAM
- Formfactor 25x20 mm
 - All components mounted on PCB top side and solder pads (LGA) on PCB bottom side
- Single supply operating voltage 1.8-3.6V
- Operating temperature -40° to 85°C
- Included on XE132 evaluation board with LH132 lens kit support for evaluation purpose
- External I/F support - UART, I2C, GPIO, Reset
- SWD/JTAG for SW flash and debug.

The XM132 Entry Module can be used for accurate distance measurement, tank level measurement, waste bin level measurement, parking space occupancy detection and smart presence detection:

- High precision distance measurements with configurable update frequency.
- Measures absolute range up to 7 m with an absolute accuracy in mm.
- Possible to recognize movement of multiple objects.

Easy integration:

- XM132 Entry Module can be integrated behind plastic or glass without any need for a physical aperture. See ref [6] *Hardware and physical integration guideline* for more information.
- LGA solder pads support for easy integration.



2.3 Block diagram

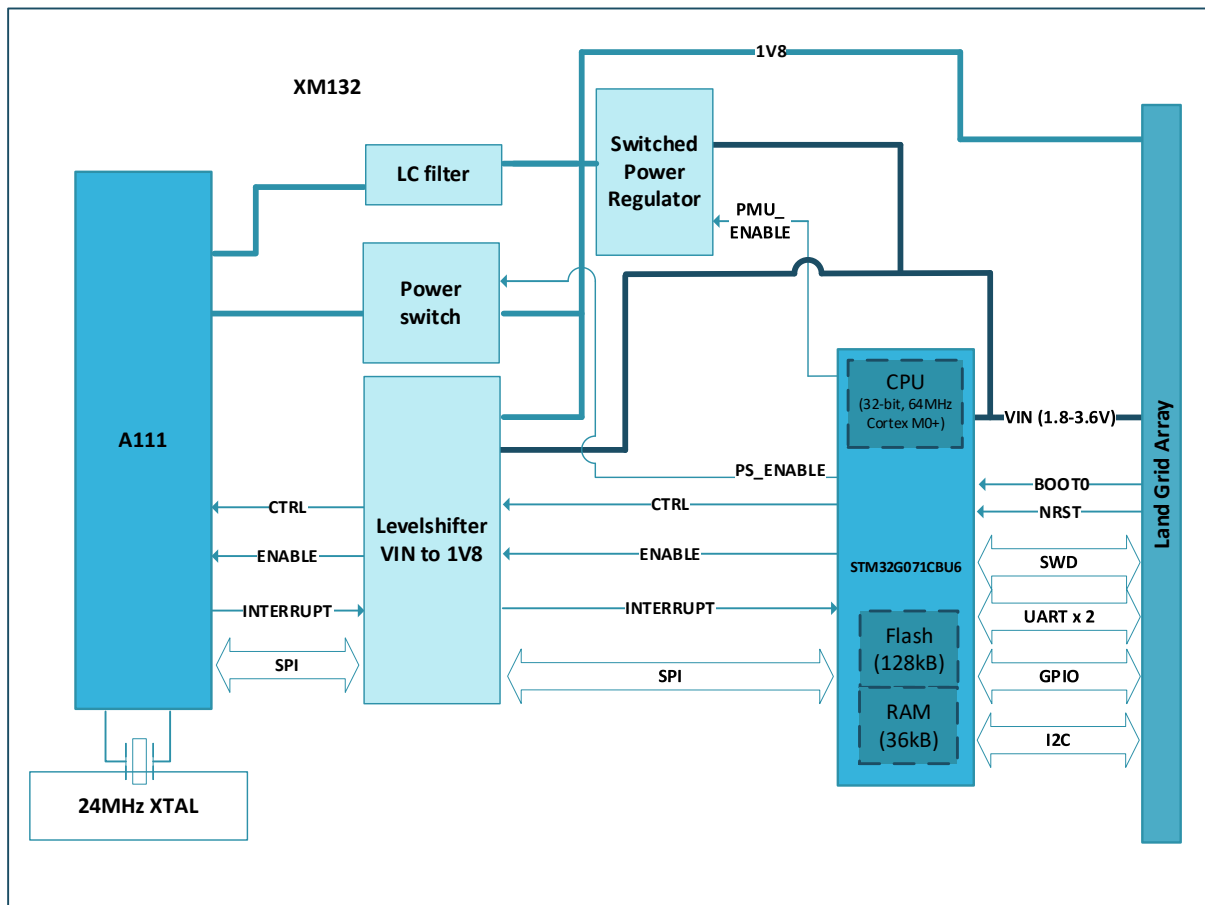

Figure 2.1. XM132 block diagram.

The XM132 block diagram shows the A111 60 GHz PCR radar connected to the M0+ microcontroller. The module provides Land Grid Arrays pads where the MCU external I/F are accessible including single voltage supply.



2.4 Module board Land Grid Array description

The LGA pads provides the external interface to the module. Figure 2.2 provides an overview of the XM132 LGA and Table 2.1 describes each signal.

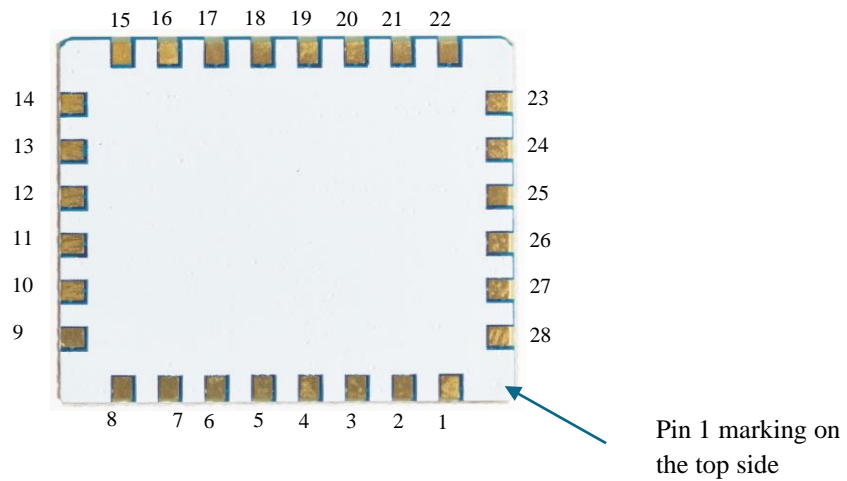

Figure 2.2. XM132 Land Grid Array.

Table 2.1. The pinning of the XM132 Land Grid Array.

Pin Number	Signal	Comment
1	VIN	1.8-3.6V, typical 3.3V
2	Ground	
3	MISC_GPIO1	
4	UART_TX	Connect to UART_RX on host side.
5	UART_RX	Connect to UART_TX on host side.
6	Ground	
7	UART_CTS	Connect to UART_RTS on host side.
8	UART_RTS	Connect to UART_CTS on host side.
9	SWD_IO	
10	Ground	
11	SWD_CLK_BOOT0	SWD_CLK and BOOT0 pin. Pulling BOOT0 high during boot of module will start the embedded boot loader.
12	WAKE_UP	Could be used by host to wake up XM132 MCU.
13	Ground	
14	I2C_SCL	
15	I2C_SDA	
16	NRESET	Reset of XM132 MCU.
17	Ground	
18	MISC_GPIO2	



19	MISC_GPIO0	
20	Ground	
21	DEBUG_UART_TX	Connect to UART_RX on host side.
22	DEBUG_UART_RX	Connect to UART_TX on host side.
23	MCU_INT	Could be used to send interrupt from XM132 MCU to host.
24	Ground	
25	I2C_ADDRESS	For configuration of I2C address.
26	Ground	
27	1V8	Output from XM132 switched power regulator.
28	Ground	



2.5 Software options

The XM132 Entry Module can be used in two regimes:

- **Stand-alone module:** The module operates as an independent system. The application is customized to a specific use case by the customer and runs on the embedded MCU. The customer's application is accessing the RSS API.
- **Controlled module:** The module is connected to an external host where the customer runs their application software. The customer is accessing the RSS API via a hardware interface through the module server, that provides register command protocol. The module output is either detector output data or service radar data through the XM132 external interfaces such as UART and I2C.

Using the XM132 Entry Module as stand-alone module Acconeer offers SDK that provides RSS, hardware abstraction layer, device drivers and build system. Based on SDK it is possible for the customer to develop their own application. Both RSS and applications run on the embedded MCU.

Using the XM132 Entry Module as Controlled module Acconeer provides SW image including RSS and module server application that provides hardware interface accessing the RSS API through a register command protocol, see ref [3].

For further software information, see XM132 Entry Module Evaluation Kit User guide, ref [2].



3 Interfaces

3.1 Module supply input

The XM132 Entry Module support 1.8-3.6V external single power supply, see table 4.2 recommended operating conditions. Note that supply voltage conditions (e.g. slew rate) need to be taken into consideration according to STM M0+ microcontroller datasheet, ref [5].

3.2 System functions

The XM132 module supports system power states, see XM132 Module Software User guide, Ref [3] for further information.

Module RESET is supported by activating NRST pin (active low).

Module ERASE is used to reinitialize the MCU Flash content and some of its NVM (Non-Volatile Memory) bits to an erased state. See also STM M0+ microcontroller datasheet, ref [5] for further information.

3.3 Serial interfaces

The XM132 GPIO pins can be configured to support up to two UARTs, the communication UART and a debug UART. The main UART has support for flow control. The XM132 support up to two I2C compatible 2-wire master/slave external serial interfaces. See table 2.1 for HW configuration. See also STM M0+ microcontroller datasheet, ref [5] for further information.

The XM132 has JTAG/SWD interface for debugging and flashing. See table 2.1 for HW configuration.

3.4 I/O interfaces

The XM132 Entry Module support three General Purpose IOs (GPIOs), MISC_GPIO0, MISC_GPIO1 and MISC_GPIO2. The GPIO pins are configurable for different functions, only the debug and RESET pins are fixed to specific GPIOs. See table 2.1 for HW configuration. See also STM M0+ microcontroller datasheet, ref [5] for further information.

The XM132 has a wake-up pin (WAKE_UP) which can be used to wake up the module.

3.5 Module reset

The XM132 has an external reset option (Pin 16 on the XM132).



4 Electrical specifications

4.1 Absolute maximum ratings

The below table shows the XM132 absolute maximum ratings over operating temperature range, unless otherwise noted:

Parameter	Description	Min.	Max.	Unit
V _{IN}	power supply	-0.3	4.0	V
I/O	Voltage on I/O pins	-0.3	4.0	V
T _{OP}	Operating temperature range	-40	85	°C
T _{STG}	High temperature storage		125	°C

Table 4.1. Absolute maximum ratings.

Stresses beyond those listed in table 4.1 may cause permanent damage to the device. These are stress ratings only and functional operation of the device at these conditions or at any other conditions beyond those indicated under Recommended Operating Conditions is not implied. Exposure to absolute-maximum-rated conditions for extended periods of time may affect device reliability.

4.2 Recommended operating conditions

The below table shows the XM132 recommended operating conditions:

Parameter	Min.	Typ.	Max.	Unit
V _{IN} , operating power supply voltage	1.8		3.6	V
I/O operating range	0		3.6	V
Operating temperature	-40		85	°C

Table 4.2. Recommended operating conditions.



4.3 Power consumption summary

The below table summarizes the XM132 power consumption, average current ratings at power terminal at $T_A = 25^\circ\text{C}$ and 1.8 V supply:

Parameter	Min.	Typ.	Max.	Unit
Measuring window: 1.0m, 0.1Hz update rate, sensor off		0.051 ⁽¹⁾		mW
Measuring window: 2.5m, 20Hz update rate, sensor hibernate		8.839 ⁽¹⁾		mW
Idle current		4.3 ⁽²⁾		uA

Table 4.3. Average power dissipation ratings at power terminal.

¹Configuration with Sparse service, profile 3 used.

²STM M0+ microcontroller is in sleep mode (Stop Mode 1) with full RAM retention and wake-up on RTC enabled.

4.4 RF specification

The module RF specification is given in Table 4.4.

Parameter	Min.	Typ.	Max.	Unit
Simulated Tx half power beamwidth, E-plane		57		degrees
Simulated Tx half power beamwidth, H-plane		65		degrees

Table 4.4. XM132 RF specification.



4.5 Typical characteristics, Radar Loop Gain pattern

The Radar Loop Gain (RLG) pattern includes the gain in both the TX and RX radar paths and is defined as the angular separation between the two points at which the gain has decreased by 3 dB relative to the maximum main lobe value, when the radar itself is used to measure the reflected power.

Conditions: $T_A = 25\text{ }^\circ\text{C}$. Tested on 5 XM132 devices.

Figure 4.1 shows the RLG radiation pattern normalized to free space sensor boresight at elevation plane (E-plane) and azimuth plane (H-plane).

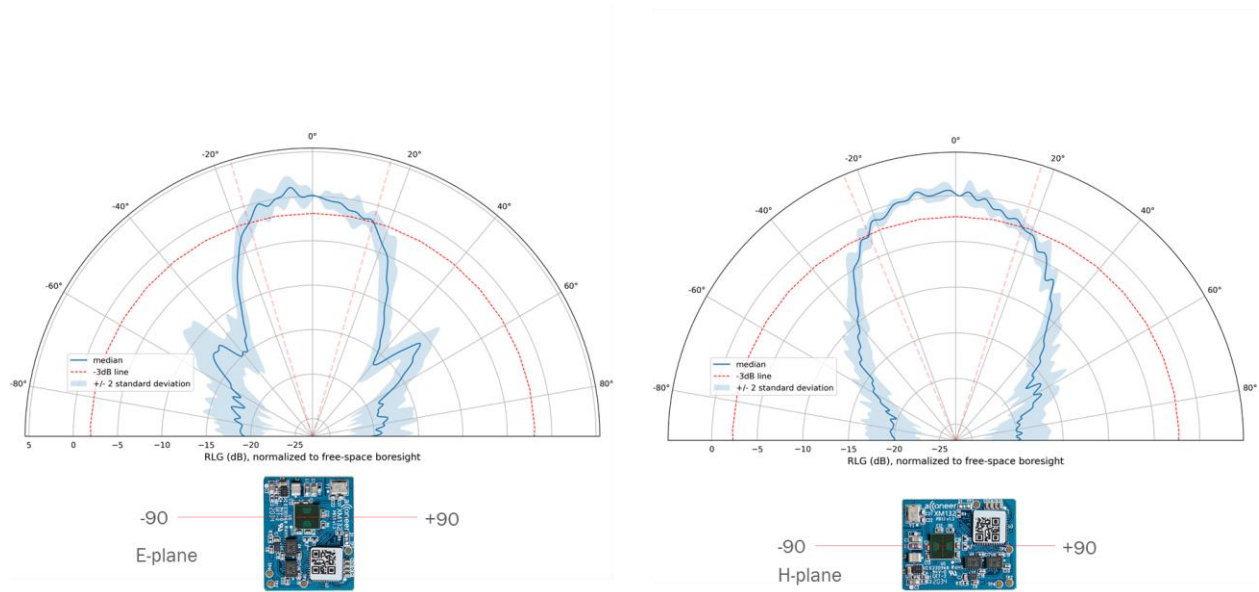

Figure 4.1. Radar Loop Gain (RLG) radiation patterns (normalized).



5 Reference design description XM132

5.1 Schematics & BOM

The following pages include the module schematics and bill of materials:

THIS DOCUMENT AND THE DATA DISCLOSED HEREIN OR HEREWITH IS CONFIDENTIAL AND THE PROPERTY OF ACCONEER AB.

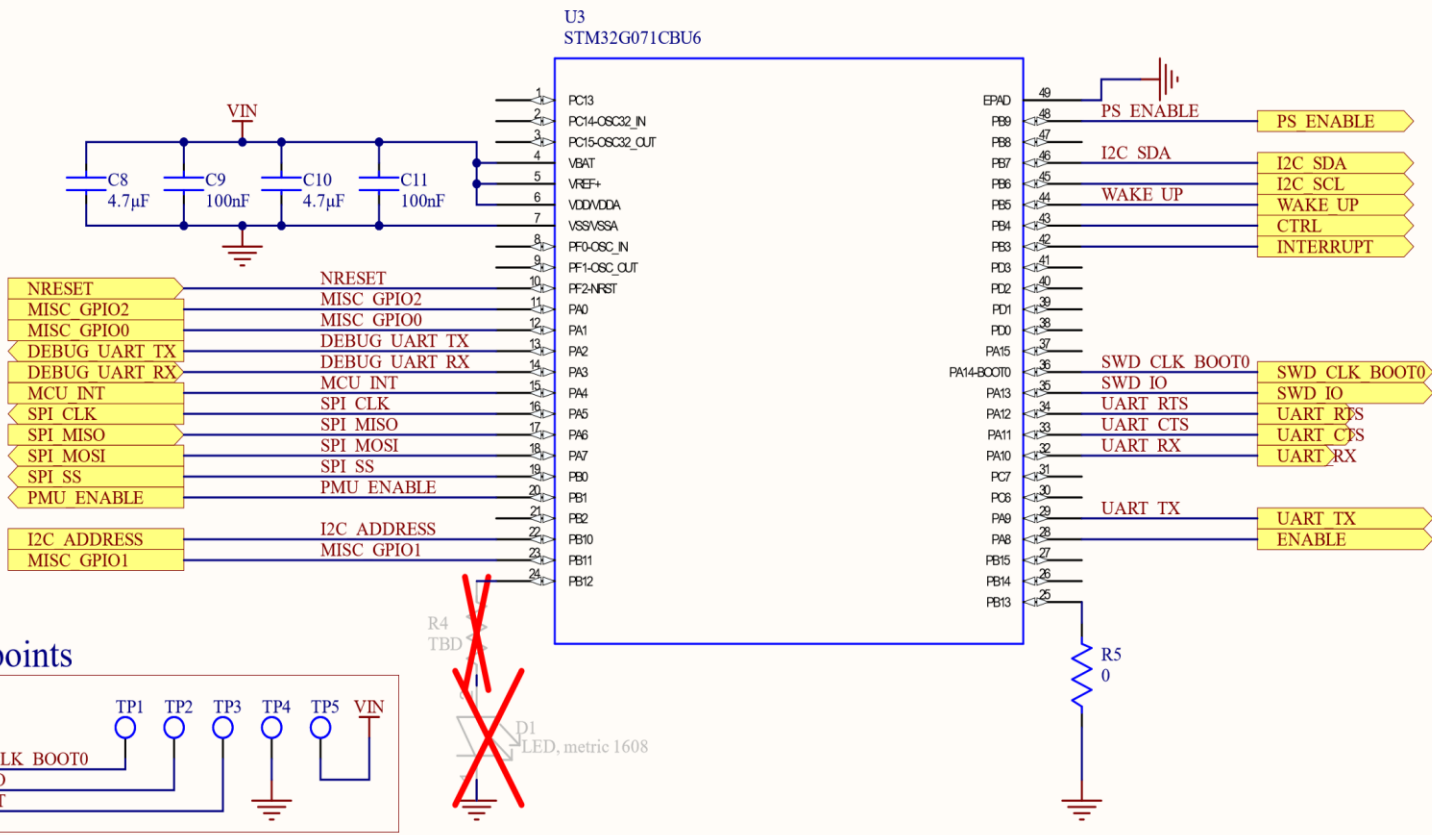

Title		XM132: MCU		aconeer	
Size	Project variant	PB number	PCBA version		
A4	Production	PB13			
Date: 2022-07-08		Sheet 1 of 3			
File: MCU.SchDoc		Drawn By: Anton Evertsson			

THIS DOCUMENT AND THE DATA DISCLOSED HEREIN OR HEREWITH IS CONFIDENTIAL AND THE PROPERTY OF ACCONEER AB.

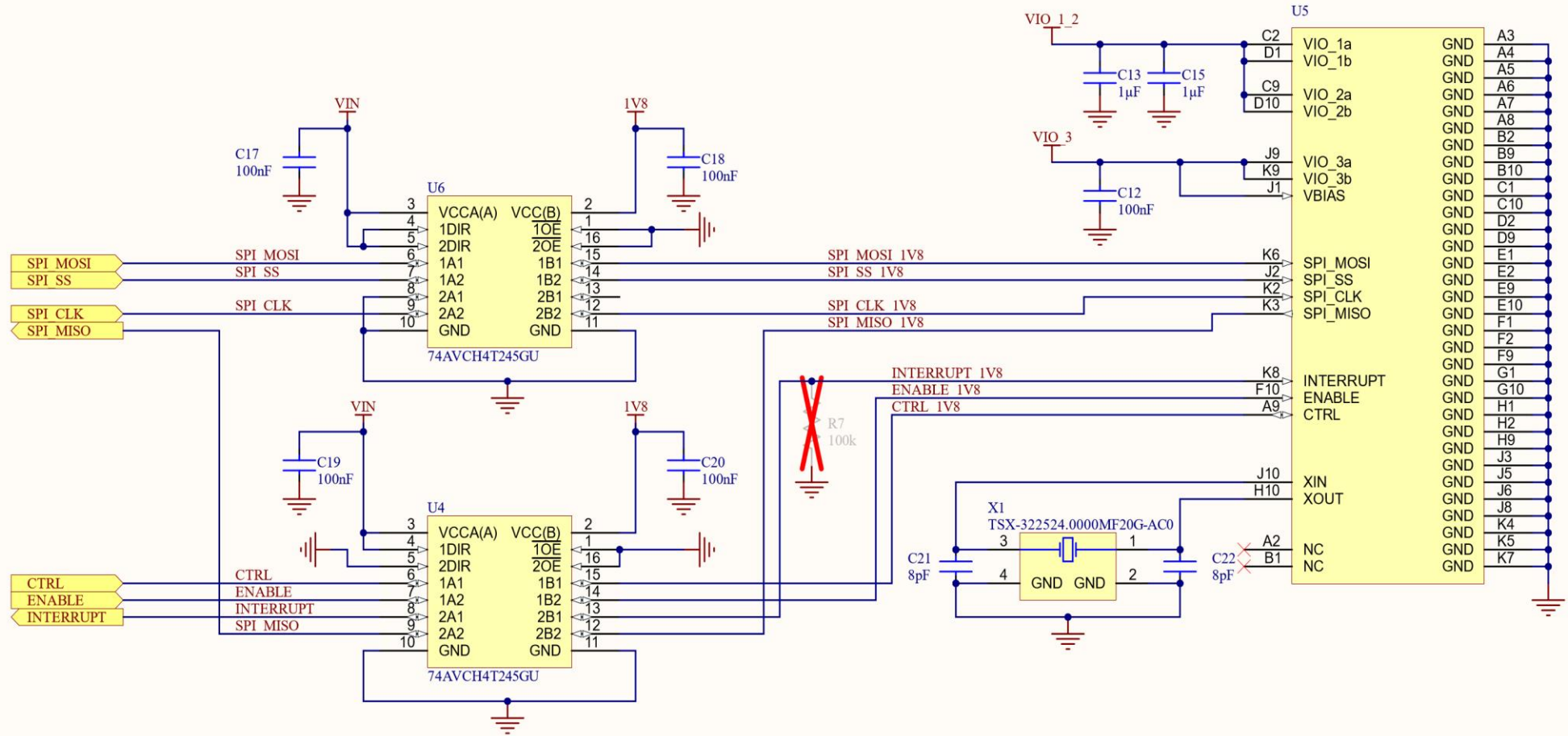

Title		XM132: Radar sensor		aconeer	
Size	Project variant	PB number	PCBA version		
A4	Production	PB13			
Date:	2022-07-08	Sheet	3 of 3		
File:	SENSOR.SchDoc	Drawn By:	Anton Evertsson		



Bill of Material

Table 5.1 shows the BOM for XM132.

Component Ref.	Specification	QTY	Value	Comment
C1	22uF 10V X5R 0603	1	22 uF	
C3, C5	10uF 16V X5 0603	2	10 uF	
C4, C7, C9, C11, C14, C15, C16, C17, C18, C19, C20	Chip Capacitor 0402 X7R 100nF 10% 50V	11	100 nF	
C6, C13, C15	Chip Capacitors 0402 X5R 1uF 10% 10V	3	1 uF	
C8, C10	Chip Capacitors 4.7uF 10V X5R 0402	2	4.7 uF	
C21, C22	Chip Capacitor 0402 COG 8pF 5% 50V	2	8 pF	
R1	Chip Resistor 0402 5% 0.39R	1	0.39 Ohm	
R5	Chip Resistor 0402 5% 0R	1	0 Ohm	
L1	IND1608 Inductors 2.2uH 20% 500mA	1	2.2 uH	TDK: MLZ1608N2R2LT000
L2	2520 2.2uH 20% -40~+125°C	1	2.2 uH	Abracon LLC: ASMPH-1008-2R2M-T Alternative: Murata: DFE252012P-2R2M=P2
B1	Ferrite Bead 0402	1		TDK: MMZ1005S601CT000
Y1	24MHz 10ppm Crystal 9pF ESR 40Ohms	1	24 MHz	Epson: TSX-3225 24.0000MF20G-AC
U1	Ultra-Low Leakage Load Switch	1		Vishay: SIP32431DNP3- T1GE4
U2	Switched Voltage Regulator	1		TI: TPS62840DLCR
U3	MCU STM32G071CBU6 32-bit LQFP48	1		ST Microelectronics: STM32G071CBU6
U4, U6	Bidirectional Voltage Level Translator, 74AVCH4T245BQ SOT763-1	2		Nexperia: 74AVCH4T245BQ
U5	Radar Sensor 60 GHz A111	1		Acconeer AB: A111



5.2 Mechanical specifications and footprint

The component placement drawing of XM132 shown in Figure 5.1.

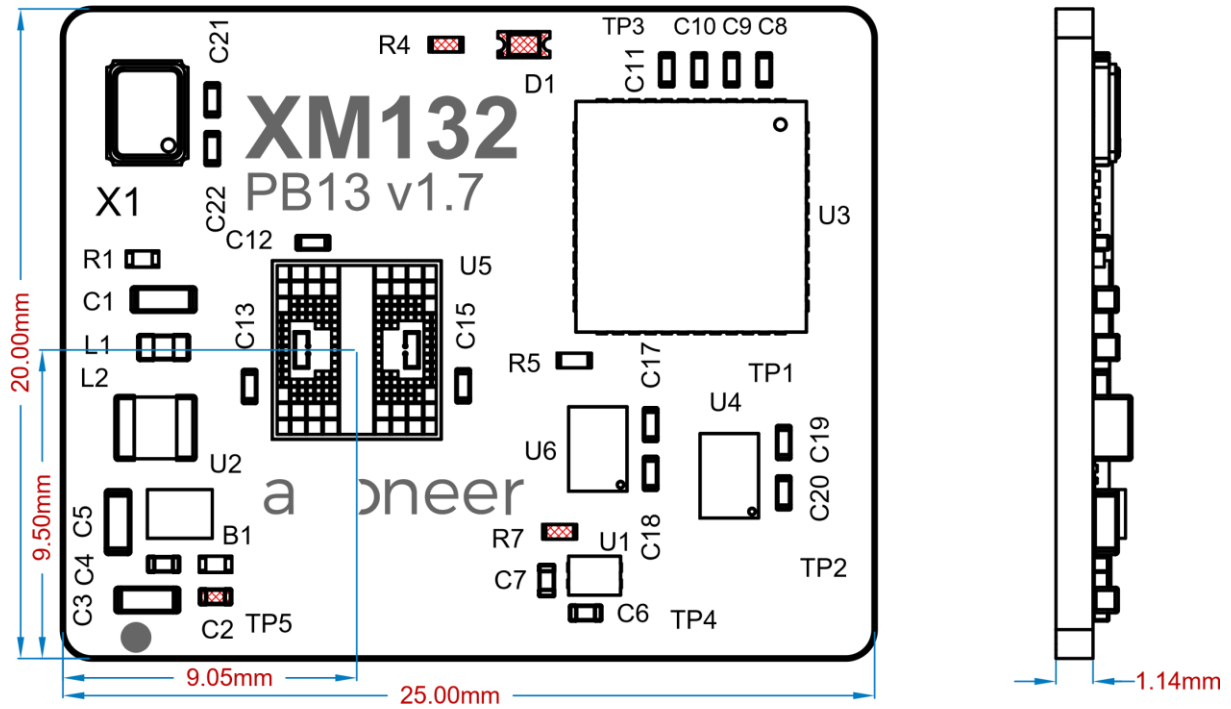
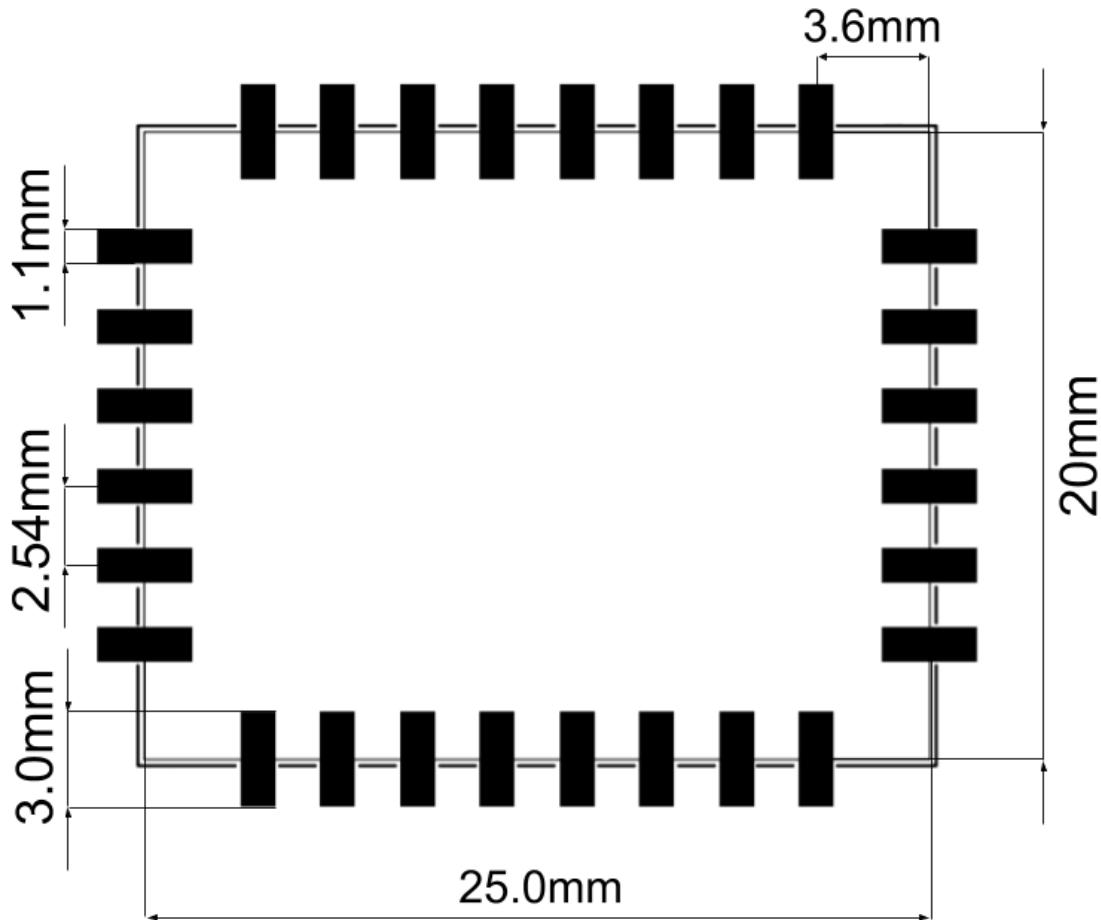

Figure 5.1. Component placement top and side views.



XM132 Recommended footprint



5.3 Moisture Sensitivity Level and Recommended Reflow Profile

XM132 module is moisture sensitive and need to be handled within proper Moisture Sensitive Level 3 (MSL3) guidelines to avoid damage from moisture absorption and exposure to solder reflow temperatures that can result in yield and reliability degradation.

Refer to IPC/JEDEC J-STD-033D for details regarding Handling, Packing, Shipping and Use of Moisture, Reflow, and Process Sensitive Devices.

XM132 is baked and dry-packed before shipment from Acconeer AB according to MSL3.

Maximum number of reflow passes recommended for XM132 is one (1).

It is recommended to use a reflow profile compatible with the IPC/JEDEC J-STD-020E classification profile.

5.4 RoHS and REACH Statement

Acconeer XM132 Entry Module meet the requirements of Directive 2011/65/EC of the European Parliament and of the Council on the Restriction of Hazardous Substances (RoHS) and the requirements of the REACH regulation (EC 1907/2006) on Registration, Evaluation, Authorization and Restriction of Chemicals.





6 Regulatory Approval

To be noted is that some regulatory specifications also specify usage of the module, so users of the module must check regulatory requirements for their own use case and determine if the regulatory approvals described below are sufficient.

6.1 ETSI

Hereby, Acconeer declares that the XM132 module is compliant with directive 2014/53/EU. The XM132 module fulfills the CE marking.

EU Type Examination Certificate





Bundesnetzagentur
BN132A-115-02/51-52
authorized by the German Government to act as Notified Body in accordance with the RE Directive 2014/53/EU of 16 April 2014.

Certificate Holder: Acconeer AB,
Ideon Gateway, Scheelevägen 27,
22370 Lund,
SWEDEN

Product Manufacturer: See Certificate Holder

Product Designation: XM132

Product Description: 60 GHz Module

Conformity Assessment:

Essential requirements	Examined documentation	Result
EMC RED, Article 3.1b	Technical documentation including test report	conform
Radio spectrum RED, Article 3.2	Technical documentation including test report	conform

EU Type Examination Certificate:
In accordance with Annex III of the European Council Directive 2014/53/EU on radio equipment, our opinion is that this equipment type complies with the essential requirements stated above.

Marking:
The product shall be marked with the CE marking as required in the Council Directive 2014/53/EU.

Annexes:
The certificate is only valid in conjunction with the following number of annexes: 1

Validity:
Conformity is provided unless changes/modifications have been done to the standard and/or assessed type of equipment.

Certificate Registration No.:

CE 0682

Saarbrücken

T818779M-01-TEC

CTC advanced GmbH

Uwe Nauertz

Authorized signature / title



GERMAN NOTIFIED BODY
EUROPEAN ID-NO. 0682

cn=Uwe Nauertz, o=CTC advanced GmbH,
ou=NAU-200128,
email=uwe.nauertz@ctcadva
nce3.com, c=DE
2021.02.11 10:16:04 +01'00'

CTC advanced GmbH
 Untertürkheimer Str. 6-10 | 66117 Saarbrücken | Germany | www.ctcadvanced.com



6.2 FCC

Hereby, Acconeer declares that the XM132 module is compliant with FCC – Title 47 CFR Part 15 unintentional emitter Class B. See A111 datasheet for details ref.[1].



7 Reference documents

- [1] A111 Pulsed Coherent Radar (PCR) Datasheet:
<https://developer.acconeer.com/>
- [2] XM132 Entry Module Evaluation Kit, User guide
<https://developer.acconeer.com/>
- [3] XM132 Module Software User guide
<https://developer.acconeer.com/>
- [4] XE132 IoT Evaluation board, Product brief
<https://developer.acconeer.com/>
- [5] MCU STM32G071CUB6 Datasheet:
[STM Semiconductor](https://www.st.com/en/microcontrollers-and-microprocessors/stm32g071cub6.html)
- [6] Hardware and physical integration guideline
<https://developer.acconeer.com/>



8 Abbreviations

AiP	Antenna in Package
API	Application Programming Interface
BOM	Bill of Materials
EIRP	Equivalent Isotropically Radiated Power
GND	Ground
GPIO	General Purpose Input/Output
HPBW	Half Power Beamwidth
HW	HardWare
I2C	Inter-Integrated Circuit
LGA	Land Grid Array
MCU	MicroController Unit
NVM	Non-Volatile Memory
PCR	Pulse Coherent Radar
RF	Radio Frequency
RSS	Radar System Software
SDK	Software Development Kit
SoC	System on Chip
SPI	Serial Peripheral Interface
SW	SoftWare
SWD	Serial Wire Debug
UART	Universal Asynchronous Receiver/Transmitter



Disclaimer

The information herein is believed to be correct as of the date issued. Acconeer AB (“**Acconeer**”) will not be responsible for damages of any nature resulting from the use or reliance upon the information contained herein. Acconeer makes no warranties, expressed or implied, of merchantability or fitness for a particular purpose or course of performance or usage of trade. Therefore, it is the user’s responsibility to thoroughly test the product in their particular application to determine its performance, efficacy and safety. Users should obtain the latest relevant information before placing orders.

Unless Acconeer has explicitly designated an individual Acconeer product as meeting the requirement of a particular industry standard, Acconeer is not responsible for any failure to meet such industry standard requirements.

Unless explicitly stated herein this document Acconeer has not performed any regulatory conformity test. It is the user’s responsibility to assure that necessary regulatory conditions are met and approvals have been obtained when using the product. Regardless of whether the product has passed any conformity test, this document does not constitute any regulatory approval of the user’s product or application using Acconeer’s product.

Nothing contained herein is to be considered as permission or a recommendation to infringe any patent or any other intellectual property right. No license, express or implied, to any intellectual property right is granted by Acconeer herein.

Acconeer reserves the right to at any time correct, change, amend, enhance, modify, and improve this document and/or Acconeer products without notice.

This document supersedes and replaces all information supplied prior to the publication hereof.

© 2022 by Acconeer – All rights reserved

