



V3S110-2AAAAAA

Visionary-T

3D MACHINE VISION

**SICK**  
Sensor Intelligence.



Illustration may differ



### Ordering information

Type	Part no.
V3S110-2AAAAAA	1091418

Other models and accessories → [www.sick.com/Visionary-T](http://www.sick.com/Visionary-T)

### Detailed technical data

#### Features

<b>Task</b>	Presence inspection Measuring, 3D Collision awareness
<b>Technology</b>	3D snapshot, image analysis
<b>Product category</b>	Configurable, programmable, Streaming, pre-calibrated
<b>Working distance</b>	0.5 m ... 60 m <sup>1)</sup>
<b>Example field of view</b>	7 m x 5.3 m <sup>2)</sup>
<b>Detection angle</b>	69° x 56°
<b>Angular resolution</b>	0.39° x 0.38°
<b>Light source</b>	Internal lighting LED, invisible, infrared, 850 nm
<b>LED class</b>	
<b>Factory calibrated</b>	✓
<b>Grayscale measurements</b>	✓

<sup>1)</sup> Radial distance for targets having 100% remission.

<sup>2)</sup> See table for individual values.

#### Mechanics/electronics

<b>Connection type</b>	M12 8-pin Gigabit Ethernet, X-coded M12 17-pin (voltage supply/data), system plug, digital IOs (24 V)
<b>Supply voltage</b>	24 V DC <sup>1)</sup>
<b>Power consumption</b>	≤ 22 W, Typical (without digital I/Os)
<b>Peak current</b>	3 A
<b>Enclosure rating</b>	IP67
<b>Protection class</b>	III

<sup>1)</sup> (+/-20 %), < 2,5 ms integration time  
(+/-15 %), > 2,5 ms integration time.

<sup>2)</sup> With cooling fins.

<b>Housing color</b>	Blue, black
<b>Weight</b>	1.9 kg, with cooling fins
<b>Dimensions (L x W x H)</b>	162 mm x 116 mm x 104 mm <sup>2)</sup>
<b>Mounting</b>	Any or can be determined by raster

<sup>1)</sup> (+/-20 %), < 2,5 ms integration time  
 (+/-15 %), > 2,5 ms integration time.

<sup>2)</sup> With cooling fins.

## Performance

<b>Pixel count</b>	176 px x 144 px
<b>Repeatability</b>	≥ 2 mm, at 1 m range ≥ 7 mm, at 7 m range <sup>1)</sup>
<b>On delay</b>	< 15 s
<b>Response time</b>	< 66 ms
<b>Integrated application</b>	Data stream with the option of filtering, reducing, and manipulating data inside the device

<sup>1)</sup> See table for individual values.

## Interfaces

<b>Ethernet</b>	✓
Function	With the option of polar or Cartesian data reduction
Data transmission rate	≤ 60 Mbit/s, communication interface Gigabit Ethernet (TCP/IP)
<b>Configuration software</b>	SOPAS ET, Telegram interface, API (Java), Web-Interface
<b>Digital input</b>	2
<b>Digital output</b>	4
<b>Optical indicators</b>	2 status LEDs

## Ambient data

<b>Electromagnetic compatibility (EMC)</b>	EN 61000-6-2:2005-08, EN 61000-6-4:2007-01
<b>Shock load</b>	EN 60068-2-27:2009
<b>Vibration load</b>	EN 60068-2-6, EN 60068-2-64
<b>Ambient operating temperature</b>	0 °C ... +50 °C, with cooling fins <sup>1)</sup>
<b>Storage temperature</b>	-20 °C ... +70 °C
<b>Ambient light immunity</b>	< 50 klx, Sunlight

<sup>1)</sup> The ambient operating temperature is reduced by 5 °C in speed mode to 45 °C.

## General notes

<b>Note</b>	All relevant materials for commissioning (instructions, drivers, examples, software, API) can be found in the Downloads tab under "Other downloads".
-------------	--

## Classifications

<b>ECl@ss 5.0</b>	27310205
<b>ECl@ss 5.1.4</b>	27310205
<b>ECl@ss 6.0</b>	27310205
<b>ECl@ss 6.2</b>	27310205
<b>ECl@ss 7.0</b>	27310205
<b>ECl@ss 8.0</b>	27310205

<b>ECl@ss 8.1</b>	27310205
<b>ECl@ss 9.0</b>	27310205
<b>ECl@ss 10.0</b>	27310205
<b>ECl@ss 11.0</b>	27310205
<b>ETIM 5.0</b>	EC001820
<b>ETIM 6.0</b>	EC001820
<b>ETIM 7.0</b>	EC001820
<b>ETIM 8.0</b>	EC001820
<b>UNSPSC 16.0901</b>	43211731

### Dimensional drawing (Dimensions in mm (inch))

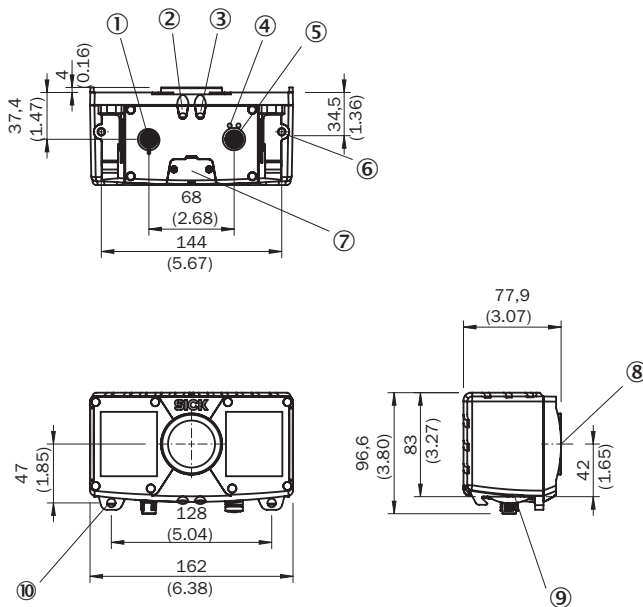

- ① Power connection / digital inputs and outputs / service
- ② Device display
- ③ Application status display
- ④ Ethernet status display
- ⑤ Ethernet connection
- ⑥ M6 blind tapped holes, 7 mm deep (2 x), for mounting
- ⑦ Service interface
- ⑧ Optical axis
- ⑨ Interface bracket
- ⑩ Bracket mounting (accessories)

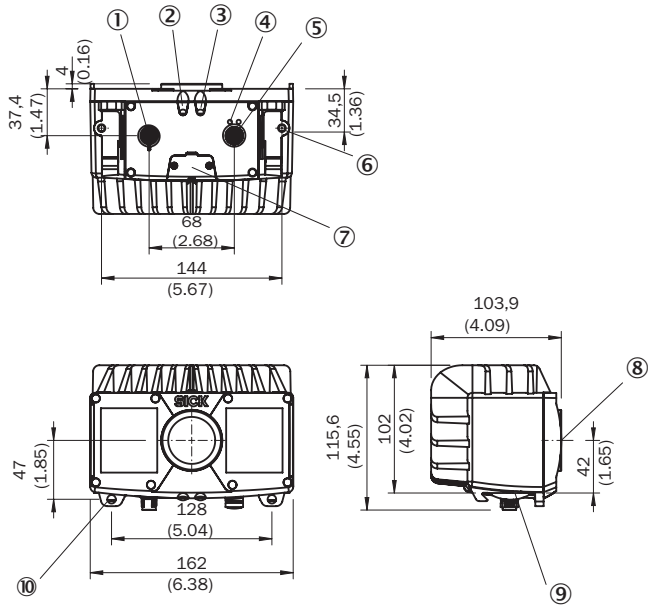

- ① Power connection / digital inputs and outputs / service
- ② Device display
- ③ Application status display
- ④ Ethernet status display
- ⑤ Ethernet connection
- ⑥ M6 blind tapped holes, 7 mm deep (2 x), for mounting
- ⑦ Service interface
- ⑧ Optical axis
- ⑨ Interface bracket
- ⑩ Bracket mounting (accessories)

## Field of view

Detection zone and field of view ( $\Delta x \times \Delta y$ )

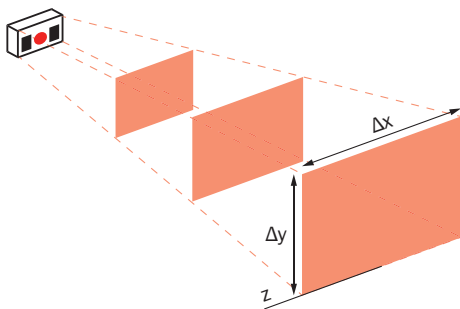

Working distance absolute (z)	Range ( $\Delta x$ )	Range ( $\Delta y$ )
0,5 m	0,7 m	0,5 m
1,0 m	1,4 m	1,0 m
1,5 m	2,1 m	1,6 m
2,0 m	2,8 m	2,1 m
3,0 m	4,1 m	3,1 m
4,0 m	5,5 m	4,2 m
5,0 m	6,8 m	5,3 m
10,0 m	13,7 m	10,6 m

Working distance absolute (z)	Range ( $\Delta x$ )	Range ( $\Delta y$ )
15,0 m	20,6 m	15,9 m
20,0 m	27,4 m	21,2 m
40,0 m	54,9 m	42,5 m

Working distance radial/absolute

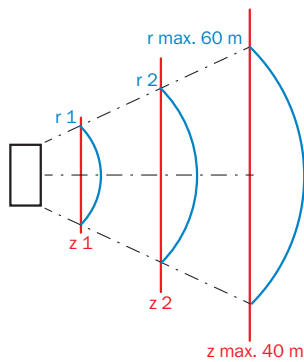

Absolute accuracy (z-axis) and repeatability at 10 % and 100 % remission and without background light (central detection zone)

Working distance radial (r)	Measurement accuracy (100% remission)	Repeatability (1 $\sigma$ - 100% remission)	Measurement accuracy (10% remission)	Repeatability (1 $\sigma$ - 10% remission)
0,5 m	± 15 mm	± 2 mm	± 15 mm	± 2 mm
1,0 m	± 15 mm	± 2 mm	± 15 mm	± 3 mm
2,0 m	± 15 mm	± 2 mm	± 20 mm	± 6 mm
3,0 m	± 15 mm	± 3 mm	± 35 mm	± 10 mm
4,0 m	± 20 mm	± 3 mm	± 50 mm	± 20 mm
5,0 m	± 25 mm	± 4 mm	± 50 mm	± 25 mm
7,0 m	± 35 mm	± 7 mm	-	-
10,0 m	± 50 mm	± 15 mm	-	-
15,0 m	± 50 mm	± 30 mm	-	-
20,0 m	± 50 mm	± 50 mm	-	-

### Connection type

Digital I/O

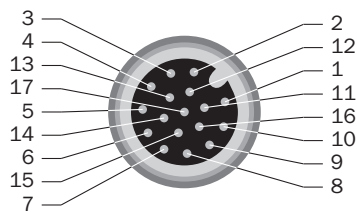

M12, 17-pin male connector

- ① GND – reference mass
- ② Supply voltage
- ③ CAN L – reserved, not implemented. Do not connect to VCC!
- ④ CAN H – reserved, not implemented. Do not connect to VCC!
- ⑤ TD+ (RS-422/485) Host – reserved, not implemented. Do not connect to VCC!
- ⑥ TD- (RS-422/485) Host, TxD (RS-232), Host – reserved, not implemented. Do not connect to VCC!
- ⑦ TxD (RS-232), Aux – service only
- ⑧ RxD (RS-232), Aux – service only
- ⑨ SENS GND – GND for electrically decoupled inputs
- ⑩ SENS IN1 – switch input, electrically decoupled
- ⑪ RD+ (RS-422) Host – reserved, not implemented. Do not connect to VCC!
- ⑫ RD- (RS-422/485) Host, RxD (RS-232), Host – reserved, not implemented. Do not connect to VCC!
- ⑬ INOUT 1 – programmable digital I/O
- ⑭ INOUT 2 – programmable digital I/O
- ⑮ SENS IN2 – switch input, electrically decoupled
- ⑯ INOUT 3 – programmable digital I/O
- ⑰ INOUT 4 – programmable digital I/O

Gigabit Ethernet

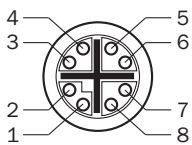



M12, 8-pin female connector, X-coded (Gigabit Ethernet)

- ① TRD0\_P
- ② TRD0\_N
- ③ TRD1\_P
- ④ TRD1\_N
- ⑤ TRD3\_P
- ⑥ TRD3\_N
- ⑦ TRD2\_P
- ⑧ TRD2\_N

Recommended accessories

Other models and accessories → [www.sick.com/Visionary-T](http://www.sick.com/Visionary-T)

	Brief description	Type	Part no.
<b>Plug connectors and cables</b>			
	Head A: female connector, M12, 17-pin, straight, A-coded Head B: Flying leads Cable: Power, serial, CAN, digital I/Os, suitable for 2 A, Changed color coding of the flying leads, PE-X, shielded, 3 m	YF2ASD-030XXXXLECX	2070425
	Head A: female connector, M12, 17-pin, straight, A-coded Head B: Flying leads Cable: Power, serial, CAN, digital I/Os, suitable for 2 A, Changed color coding of the flying leads, PE-X, shielded, 5 m	YF2ASD-050XXXXLECX	2070426
	Head A: female connector, M12, 17-pin, straight, A-coded Head B: male connector, M12, 17-pin, straight, A-coded Cable: Power, serial, CAN, digital I/Os, suitable for 2 A, shielded, 3 m	YM2A8D-030XXXF2A8D	6051194
	Head A: male connector, M12, 8-pin, straight, X-coded Head B: male connector, RJ45, 8-pin, straight Cable: Ethernet, Gigabit Ethernet, PUR, halogen-free, shielded, 2 m	YM2X18-020EG1MRJA8	2106258
	Head A: male connector, M12, 8-pin, straight, X-coded Head B: male connector, RJ45, 8-pin, straight Cable: Ethernet, Gigabit Ethernet, PUR, halogen-free, shielded, 5 m	YM2X18-050EG1MRJA8	2106259

	Brief description	Type	Part no.
Terminal and alignment brackets			
	1 piece, Bracket including clamps and screws, metal, Bracket including clamps and screws	Mounting set (2-part) incl. clamps and screws	2077710
	1 piece, 2x clamps and 2x screws, metal, 2 clamps and 2 screws	2x clamps, 2x screws	2077709

### Recommended services

Additional services → [www.sick.com/Visionary-T](http://www.sick.com/Visionary-T)

	Type	Part no.
Warranty extensions		
<ul style="list-style-type: none"> <li>• <b>Product area:</b> Identification solutions, machine vision, Distance sensors, Detection and ranging solutions</li> <li>• <b>Range of services:</b> The services correspond to the scope of the statutory manufacturer warranty (SICK general terms and conditions of purchase)</li> <li>• <b>Duration:</b> Five-year warranty from delivery date.</li> </ul>	Extended warranty for a total of five years from delivery date	1680671



## SICK AT A GLANCE

SICK is one of the leading manufacturers of intelligent sensors and sensor solutions for industrial applications. A unique range of products and services creates the perfect basis for controlling processes securely and efficiently, protecting individuals from accidents and preventing damage to the environment.

We have extensive experience in a wide range of industries and understand their processes and requirements. With intelligent sensors, we can deliver exactly what our customers need. In application centers in Europe, Asia and North America, system solutions are tested and optimized in accordance with customer specifications. All this makes us a reliable supplier and development partner.

Comprehensive services complete our offering: SICK LifeTime Services provide support throughout the machine life cycle and ensure safety and productivity.

For us, that is “Sensor Intelligence.”

## WORLDWIDE PRESENCE:

Contacts and other locations –[www.sick.com](http://www.sick.com)