

Multi-Band GNSS Raw Data Module

TAU1302

Datasheet V1.6

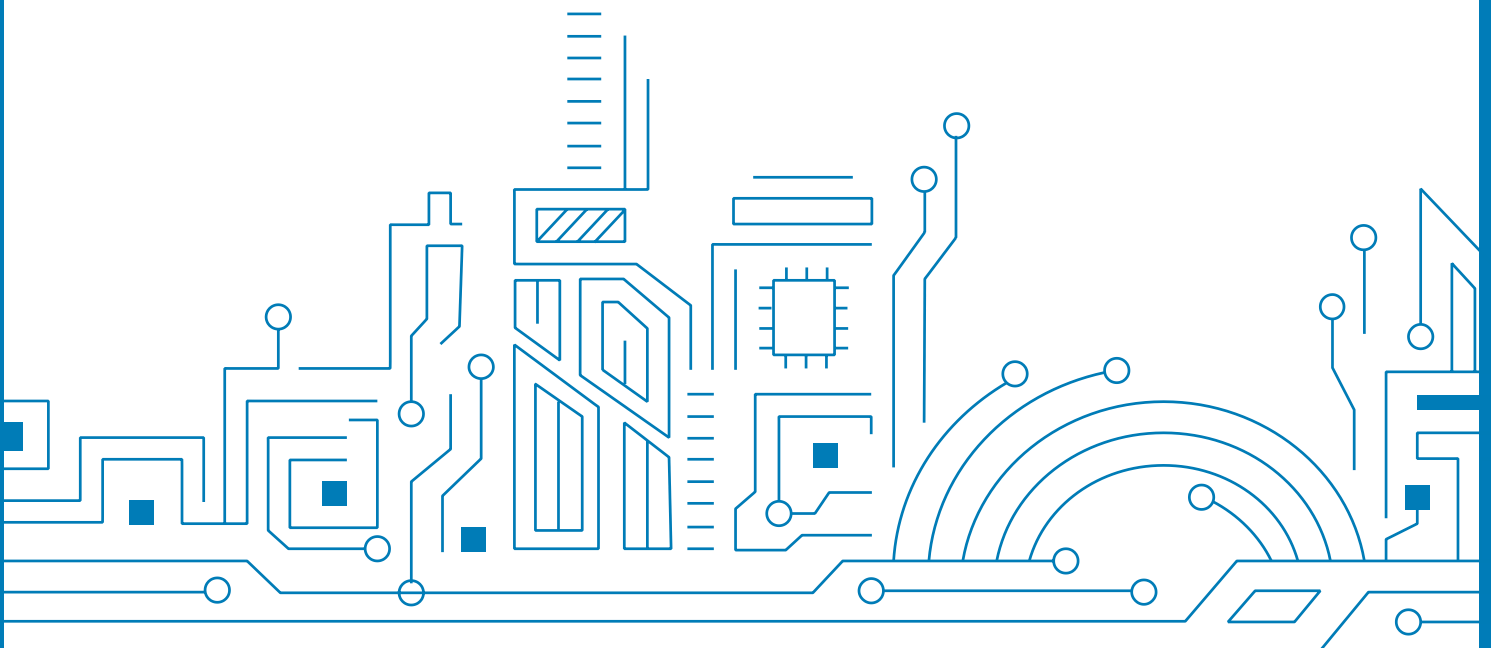

Notice, Statement and Copyright

ALLYSTAR Technology offers this document as a service to its customers, to support application and engineering efforts that use the products designed by ALLYSTAR Technology. Products and specifications discussed herein are for reference purposes only. Performance characteristics listed in this document do not constitute a warranty or guarantee of product performance.

ALLYSTAR Technology assumes no liability or responsibility for any claims or damages arising out of the use of this document, or from the use of integrated circuits based on this document, including, but not limited to claims or damages based on infringement of patents, copyrights or other intellectual property rights.

This document contains proprietary technical information which is the property of ALLYSTAR Technology, copying of this document and giving it to others and using or communication of the contents thereof, are forbidden without express authority. Offenders are liable to the payment of damages. ALLYSTAR Technology reserves the right to make changes in its products, specifications and other information at any time without notice.

For more recent documents, please visit www.allystar.com.

Copyright © Allystar Technology (Shenzhen) Co., Ltd. 2021. All rights reserved.

About the Document

■ Basic info

Document applies to	TAU1302
Document type	Datasheet
Revision and date	V1.6/2021-11
Product status	Mass production

■ Product status description

In development	Objective specification. Revision may be released in later status.
Engineering sample	Product specifications tested on early. Revision may be released in later status.
Preliminary	Product specifications come from small production. Revision may be released in later status.
Mass production	Final product specification to mass market.

TABLE OF CONTENT

1	SYSTEM OVERVIEW	6
1.1	Overview	6
1.2	Features	6
1.3	Module photo	6
1.4	Block diagram	7
1.5	Specifications	7
1.6	GNSS Reception	8
2	PIN DESCRIPTION	9
2.1	Pin assignment	9
2.2	Detailed pin descriptions	10
3	ELECTRICAL CHARACTERISTICS	11
3.1	Absolute Maximum Rating	11
3.2	IO Characteristics	11
3.2.1	PRRSTX and PRTRG	11
3.2.2	USB I/O	11
3.2.3	Others	12
3.3	DC Characteristics	12
3.3.1	Operating Conditions	12
3.3.2	Power Consumption	12
4	HARDWARE DESCRIPTION	13
4.1	Connecting power	13
4.2	Power on/off Sequence	13
4.2.1	Initial system power on	13
4.2.2	Main power supply off/on in application	14
4.3	Antenna design	14
4.4	Reset and mode control	14
4.5	Serial interfaces	15
5	MECHANICAL SPECIFICATION	16
6	REFERENCE DESIGN	17
6.1	Minimal design	17
6.2	PCB Footprint Reference	18
6.3	Layout Notes	18
7	PRODUCT PACKAGING AND HANDLING	19
7.1	Packaging	19
7.1.1	Packaging Notes	19
7.1.2	Tape and Reel	19
7.1.3	Shipment Packaging	20
7.2	Storage	21
7.3	ESD Handling	21
7.3.1	ESD Handling Precautions	21
7.3.2	ESD protection measures	21
7.3.3	Moisture sensitivity level	21
8	LABELING AND ORDERING INFORMATION	22
8.1	Labeling	22
8.2	Ordering info	22

9	RELATED DOCUMENTS.....	23
10	REVISION HISTORY	23

List of tables

Table 1 TAU1302	6
Table 2 Specifications	7
Table 3 GNSS reception table	8
Table 4 Detailed pin descriptions	10
Table 5 Absolute rating.....	11
Table 6 PRRSTX and PRTRG	11
Table 7 USB signal	11
Table 8 Others	12
Table 9 Operating conditions	12
Table 10 Power consumption	12
Table 11 Default message.....	15
Table 12 Dimensions	16
Table 13 Packing hierarchy	19
Table 14 Labeling content	22
Table 15 Ordering codes.....	22

List of figures

Figure 1 TAU1302 module photo	6
Figure 2 Block diagram.....	7
Figure 3 Pin assignment (top view)	9
Figure 4 Initial system power on sequence	13
Figure 5 Main power on sequence.....	14
Figure 6 Dimensions	16
Figure 7 Minimal application diagram.....	17
Figure 8 PCB Footprint Reference.....	18
Figure 9 Tape dimensions	19
Figure 10 Reel dimensions	20
Figure 11 Packaging	20

1 SYSTEM OVERVIEW

1.1 Overview

TAU1302 is a high-performance dual-band GNSS raw data module, which is based on the state of the art CYNOSURE III architecture. It supports GPS, BeiDou, GLONASS, Galileo, and QZSS. TAU1302 integrates efficient power management architecture, while providing high precision, high sensitivity and low power GNSS solutions which make it suitable for high precision industries, like precision agriculture, surveying and mapping, deformation monitoring, Unmanned Aerial Vehicle (UAV), etc.

1.2 Features

- Compact size for high precision industry
- Concurrent reception of multi-band GNSS signals by three RF settings:
 - Option A: L1&L5
 - Option B: L1&L2
 - Option C: L1&L6
- State-of-art low power consumption
- Supports multi-band multi-system high-precision raw data output, easy for 3rd party integration
- Highly integrated module, the best cost-effective high precision GNSS solution

Table 1 TAU1302

Product	GNSS						Features						Interface				Accuracy			Grade		
	Band (S/D/T)	GPS	BDS	GLONASS	Galileo	NavIC	Built-in LNA	Programmable (flash)	Data logging	D-GNSS	Oscillator	Raw Data	UART	I2C	USB	SPI	Meter	Sub-meter	Centimeter	Standard	Professional	Automotive
TAU1302-1216A00	D	●	●	●	●			●	●	●	T	●	●	○	○	○			●		●	

T= TCXO

○=Supported upon request with special FW

1.3 Module photo



Figure 1 TAU1302 module photo

1.4 Block diagram

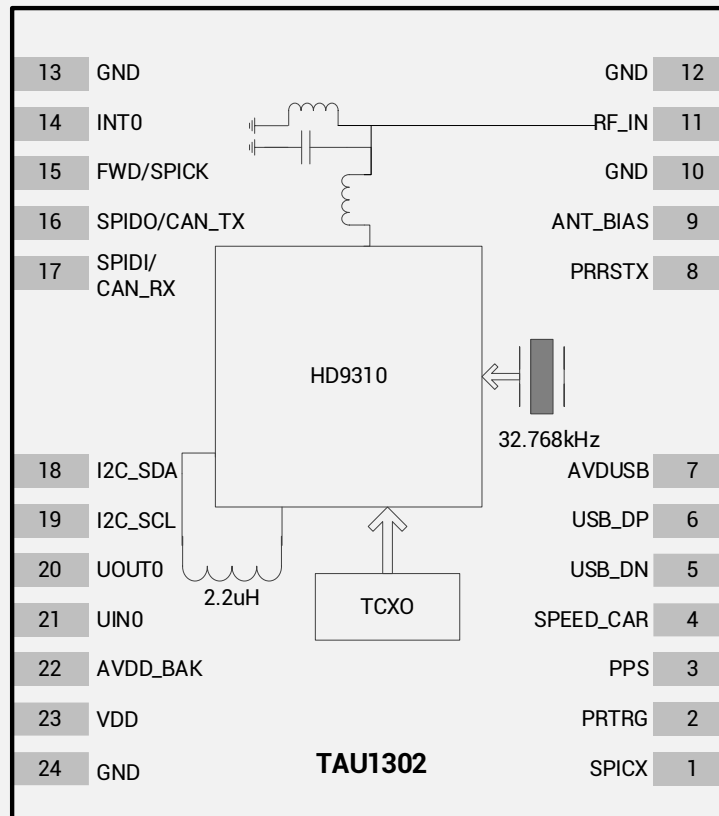

Figure 2 Block diagram

1.5 Specifications

Table 2 Specifications

Parameter	Specification	
GNSS tracking channel	40 channels	
GNSS Reception	GPS/QZSS: L1C/A, L2C, L5, L6	
	BDS: B1I, B2I, B2a, B3I	
	GLONASS: L10F, L20F	
	Galileo: E1, E5a, E6	
Update rate	Maximum 10 Hz	
Position accuracy ^[1]	GNSS	<1 m CEP
Velocity & Time accuracy	GNSS	0.1 m/s CEP
	1PPS	20ns
Time to First Fix(TTFF)	Hot start	1 sec
	Cold start	24 secs
Sensitivity	Cold start	-148 dBm
	Hot start	-158 dBm
	Reacquisition	-160 dBm
	Tracking&Navigation	-162 dBm

Parameter	Specification	
Operating limit	Velocity	515 m/s
	Altitude	18,000 m
Safety supervision	Antenna short circuit protection and open circuit detection	
Serial interface	UART	1
	SPI ^[2]	1
	USB ^[2]	1
	I2C ^[2]	1
	CAN ^[2]	1
Protocol	NMEA 0183 Protocol Ver. 4.00/4.10 Cynosure GNSS Receiver Protocol RTCM 3.0/3.2/2.3/2.4x ^[3]	
Operating condition	Main voltage	2.0V ~ 3.6V
	Digital I/O voltage	1.8V ~ 3.6V
	Backup voltage	1.8V ~ 3.6V
Power consumption	GPS+QZSS, L1 band	22 mA ^[4] @ 3.3 V
	GNSS, L1+L5 band	34 mA ^[5] @ 3.3 V
	GNSS, L1+L2 band	34 mA ^[6] @ 3.3 V
	GNSS, L1+L6 band	34 mA ^[7] @ 3.3 V
	Standby	12 uA ^[8]
Operating temperature	-40°C ~ +85°C	
Storage temperature	-40°C ~ +85°C	
Package	12.2mm x 16.0mm x 2.4mm 24-pin stamp hole	
Certification	RoHS, REACH, FCC, CE	

* [1] Demonstrated with a good external LNA

* [2] Supported upon request with special FW

* [3] RTCM 2.3/2.4x are supported upon request with special FW.

* [4] Open sky conditions, GPS+QZSS, L1 band, 16 tracked Satellites

* [5] Open sky conditions, GPS+BDS+QZSS+GLONASS+Galileo, L1+L5 band, 32 tracked Satellites

* [6] Open sky conditions, GPS+BDS+QZSS+GLONASS+Galileo, L1+L2 band, 32 tracked Satellites

* [7] Open sky conditions, GPS+BDS+QZSS+GLONASS+Galileo, L1+L6 band, 32 tracked Satellites

* [8] Standby under RTC mode, wake up by PRTRG and RTC time-out

1.6 GNSS Reception

Table 3 GNSS reception table

P/N	RF MODE	GPS/QZSS					BDS					GLONASS		Galileo			NavIC
		L1C/A	L1C	L2C	L5	L6	B1I	B1C	B2I	B2a	B3I	L1	L2	E1	E5	E6	L5
TAU1302-1216A00	A (L1+ L5) ^[1]	•	-	-	•	-	•	-	-	•	-	•	-	•	• ^[2]	-	-
	B (L1+ L2)	•	-	• ^[3]	-	-	•	-	•	-	-	•	•	•	-	-	-
	C (L1+ L6)	•	-	-	-	•	•	-	-	-	•	•	-	•	-	•	-

* [1] Default mode. Mode B and C are supported through upgrading new firmware

* [2] Supports E5a and Pilot channel only

* [3] Supports L2CM

2 PIN DESCRIPTION

2.1 Pin assignment

13	GND	GND	12
14	INT0	RF_IN	11
15	FWD/SPICK	GND	10
16	SPIDO/CAN_TX	ANT_BIAS	9
17	SPIDI/CAN_RX	PRRSTX	8
TAU1302			
18	I2C_SDA	AVDUSB	7
19	I2C_SCL	USB_DP	6
20	UOUT0	USB_DN	5
21	UIN0	SPEED_CAR	4
22	AVDD_BAK	PPS	3
23	VDD	PRTRG	2
24	GND	SPICX	1*

* Pin 1 aligns to the circular hole on module cover.

Figure 3 Pin assignment (top view)

2.2 Detailed pin descriptions

Table 4 Detailed pin descriptions

Function	Symbol	No.	I/O	Description
Power	VDD	23	Power	Main voltage supply.
	GND	10,12, 13,24	VSS	Assure a good GND connection to all GND pins of the module, preferably with a large ground plane.
	AVDD_BAK	22	Power	Backup power supply voltage input.
	AVDUSB	7	Power	USB voltage supply. To use the USB interface, connect this pin to 3.0-3.6 V.
Antenna	RF_IN	11	I	Use a controlled impedance of 50Ω for the routing from RF_IN pin to the antenna or the antenna connector.
	ANT_BIAS	9	O	RF section output voltage. The ANT_BIAS pin can be used to supply powers to an external active antenna.
UART	UOUT0	20	O	UART0 serial data output.
	UIN0	21	I	UART0 serial data input.
USB ^[1]	USB_DN	5	I/O	USB I/O line. USB bidirectional communication pin. Leave it floating if not used.
	USB_DP	6	I/O	
SPI ^[1]	SPICX	1	O	SPI chip select
	FWD/SPICK	15	O	SPI clock
	SPIDO/CAN_TX	16	O	SPI data or CAN data output, leave it floating if not used.
	SPIDI/CAN_RX	17	I	SPI data or CAN data input, leave it floating if not used.
I2C ^[1]	I2C_SDA	18	I/O	I ² C data, leave it floating if not used.
	I2C_SCL	19	I/O	I ² C clock, leave it floating if not used.
System	PRTRG	2	I	Mode selection, or the trigger input in deep sleep mode to wake up the system
	PRRSTX	8	I	External reset, low active
	PPS	3	O	Time pulse output (PPS)
	SPEED_CAR ^[1]	4	I	Speed pulse, leave it floating if not used, default GPIO
	INT0	14	I	External interrupt, leave it floating if not used, default GPIO

* [1] Supported upon request with special FW

3 ELECTRICAL CHARACTERISTICS

3.1 Absolute Maximum Rating

Table 5 Absolute rating

Symbol	Parameter	Min.	Max.	Unit
VDD	Power input for the main power domain	-0.5	3.63	V
AVDD_BAK	Power input for the backup power domain	-0.5	3.63	V
AVDUSB	USB supply voltage	-0.5	3.6	V
T _{storage}	Storage temperature	-40	85	°C
T _{solder}	Solder reflow temperature	--	260	°C

3.2 IO Characteristics

3.2.1 PRRSTX and PRTRG

Table 6 PRRSTX and PRTRG

Symbol	Parameter	Condition	Min.	Typ.	Max.	Unit
I _{IZ}	Input leakage current	--	--	--	+/-1	uA
V _{IH}	Input high voltage	--	AVDD_BAK*0.7	--	AVDD_BAK	V
V _{IL}	Input low voltage	--	0	--	AVDD_BAK*0.3	V
C _i	Input capacitance	--	--	--	10	pF
R _{PU}	Pull-up resistance	--	18	--	84	kOhm

3.2.2 USB I/O

Table 7 USB signal

Symbol	Parameter	Condition	Min.	Typ.	Max.	Unit
I _{IZ}	Input leakage current	--	--	--	+/-10	uA
V _{IH}	Input high voltage	--	AVDUSB*0.9	--	AVDUSB	V
V _{IL}	Input low voltage	--	0	--	AVDUSB*0.1	V
V _{OH}	Output high voltage	I _{OH} =10 mA, AVDUSB =3.3V	2.35	--	--	V
V _{OL}	Output low voltage	I _{OL} =10 mA, AVDUSB =3.3V	--	--	0.5	V
R _{PUIDEL}	Pull-up resistance, idle state	--	0.9	--	1.575	kΩ
R _{PUACTIVE}	Pull-up resistance, active state	--	1.425	--	3.09	kΩ

3.2.3 Others

Table 8 Others

Symbol	Parameter	Condition	Min.	Typ.	Max.	Unit
I _{IZ}	Input leakage current	--	--	--	+/-1	uA
V _{IH}	Input high voltage	--	VDD*0.7	--	VDD	V
V _{IL}	Input low voltage	--	0	--	VDD*0.3	V
V _{OH}	Output high voltage	I _{OH} =11.9 mA, VDD=3.3V	2.64	--	--	V
V _{OL}	Output low voltage	I _{OL} =7.9 mA, VDD=3.3V	--	--	0.4	V
C _i	Input capacitance	--	--	--	11	pF
R _{PU}	Pull-up resistance	--	35	--	84	kOhm

3.3 DC Characteristics

3.3.1 Operating Conditions

Table 9 Operating conditions

Symbol	Parameter	Min.	Typ.	Max.	Unit
VDD	Power input for the main power domain	2.0	3.3	3.6	V
AVDD_BAK	Power input for the backup power domain	1.8	3.3	3.6	V
AVDUSB	USB power input	3.0	3.3	3.6	V
I _{ANT_BIAS}	ANT_BIAS output current	-	-	35	mA
V _{ANT_BIAS}	ANT_BIAS output voltage	-	VDD-0.2	-	V
ICC _{max}	Maximum operating current @ VDD	--	--	200	mA
T _{env}	Operating temperature	-40	--	85	°C

3.3.2 Power Consumption

Table 10 Power consumption

Symbol	Parameter	Measure Pin	Typ.	Unit
I _{CCR1}	Average tracking current (GPS+QZSS, L1 only)	VDD ^[1]	22	mA
I _{CCR2}	Average tracking current (GNSS, L1+L5)	VDD ^[1]	34	mA
I _{CCDBM}	Standby Mode	AVDD_BAK ^[2]	12	uA

* [1] Condition: VDD=3.3V@Room Temperature; All Pins Open.

* [2] Condition: AVDD_BAK=3.3V@Room Temperature; All Pins Open.

4 HARDWARE DESCRIPTION

4.1 Connecting power

TAU1302 positioning module has two power supply pins: VDD and AVDD_BAK. The VDD pin provides the main supply voltage, and the AVDD_BAK pin provides the backup supply voltage. In order to ensure the positioning performance, please control the ripple of the module power supply. It is recommended to use the LDO with max output current above 100mA.

If the power for VDD pin is off, the real-time clock (RTC) and battery backed RAM (BBR) are supplied through the AVDD_BAK pin. Thus, orbit information and time can be maintained and will allow a Hot or Warm start. If no backup battery is connected, the module performs a cold start at every power up if no aiding data are sent to the module.

Note: If no backup supply is available, connect the AVDD_BAK pin to VDD or leave it floating.

4.2 Power on/off Sequence

The module has two independent power domains (backup and main domain). In data backup mode, main power supply can be completely shut down for further power reduction for ultra-low power application.

4.2.1 Initial system power on

When both backup and main supply power on from their off state, external reset (PRRSTX) must be active and hold more than 5ms after both backup supply and main supply reach the minimum operating voltage. Initial system power on sequence is illustrated in Figure 4.

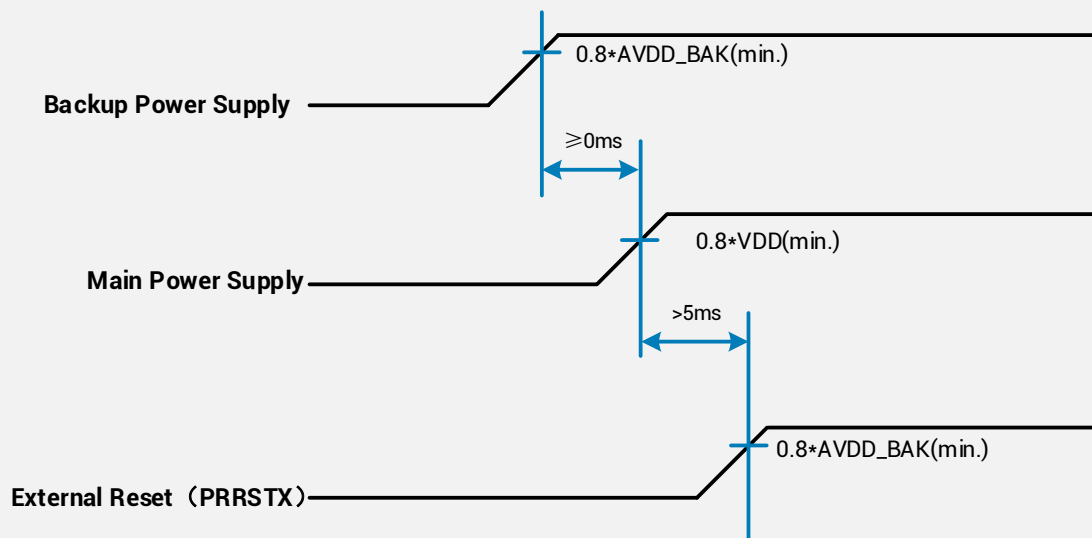

Figure 4 Initial system power on sequence

4.2.2 Main power supply off/on in application

If application intends to shut down main power supply (VDD) while keep backup power supply (AVDD_BAK) alive to save backup data, the following rules should be applied:

External reset (PRRSTX) must be active when main power supply is under power off. In this case, external reset must be hold active more than 5ms after main power supply resumes to minimum operating voltage. Main power on sequence in application is illustrated in Figure 5.

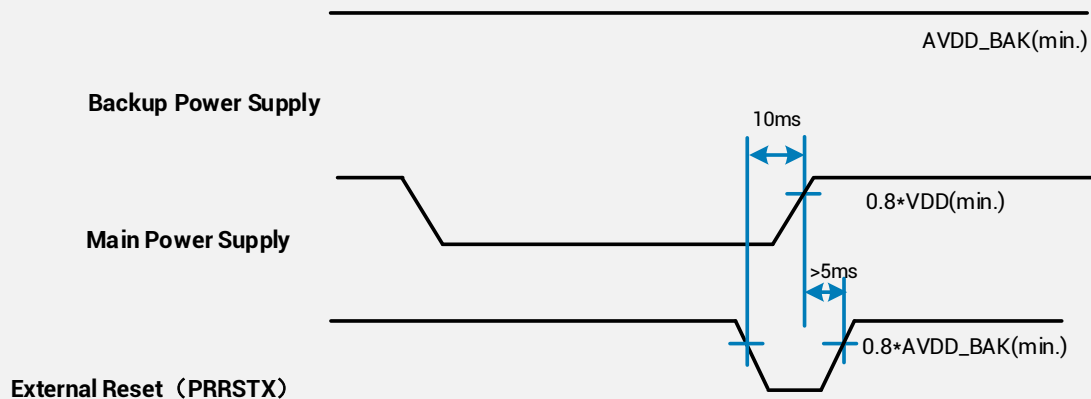

Figure 5 Main power on sequence

4.3 Antenna design

There isn't built-in LNA and SAW in the GNSS module. It is recommended to use an active antenna with gain less than 50dB and noise figure less than 1.5dB. The module has built-in short circuit detection and open circuit detection functions, which can detect the status of normal connection, and send out antenna status prompt message in NMEA data.

- Short circuit protection
 - » The module includes internal short circuit antenna detection. Once an overcurrent is detected at the ANT_BIAS port, the module will restrict the current output automatically to protect from damage.
- Open circuit detection
 - » The module can detect an open circuit in the antenna. Users can judge it from antenna status messages.

4.4 Reset and mode control

The operation mode of GNSS module is controlled by PRRSTX (nRESET) and PRTRG (BOOT) pin. While the module works in normal operation, leave PRRSTX and PRTRG pins floating if there is no upgrading or reset demands, or others.

- Keep PRTRG pin floating during system power-up or the external reset (PRRSTX from low to high), and the module will enter **User Normal Mode**.
- When the module powers up or PRRSTX from low to high, the module will execute an **external reset**.

(If the power for AVDD_BAK is always on, the external reset will not affect the ephemeris data in the backup domain)

- Drive PRTRG pin to low or connect PRTRG to GND directly (not by pull-down resistance) during system power-up or the external reset (PRRSTX from low to high), and the system enters **BootROM Command Mode** at PRTRG pin being released from low to floating state, and ready for firmware upgrading command.
- When connecting PRRSTX and PRTRG to any host IO, DO NOT use the pull-up or pull-down resistance.

4.5 Serial interfaces

Table 11 Default message

Interface	Settings
UART output	115200 baud, 8 data bits, no parity bit, 1 stop bit Configured to transmit both NMEA and HD Binary protocols, but only the following NMEA (and no HD Binary sentence) messages have been activated at start-up: GGA, GSA, GSV, RMC, ZDA, TXT-ANT
UART input	115200 baud, 8 data bits, no parity bit, 1 stop bit, autobauding disabled Automatically accepts following protocols without need of explicit configuration: HD binary sentence, NMEA, RTCM The GNSS receiver supports interleaved HD binary and NMEA messages.
Timepulse (1Hz Nav)	1 pulse per second, synchronized at rising edge, pulse length 100ms

* Refer to *GNSS_Protocol_Specification* for information about other settings.

When the module is applied to the specific application, users can shut off the main power in order to further reduce the power consumption. To avoid the high level in serial interface influencing the normal operation, it is highly suggested to cut off the serial port when shut off the main power. Otherwise, please set the serial port to input mode or high impedance state with pull-down resistor.

5 MECHANICAL SPECIFICATION

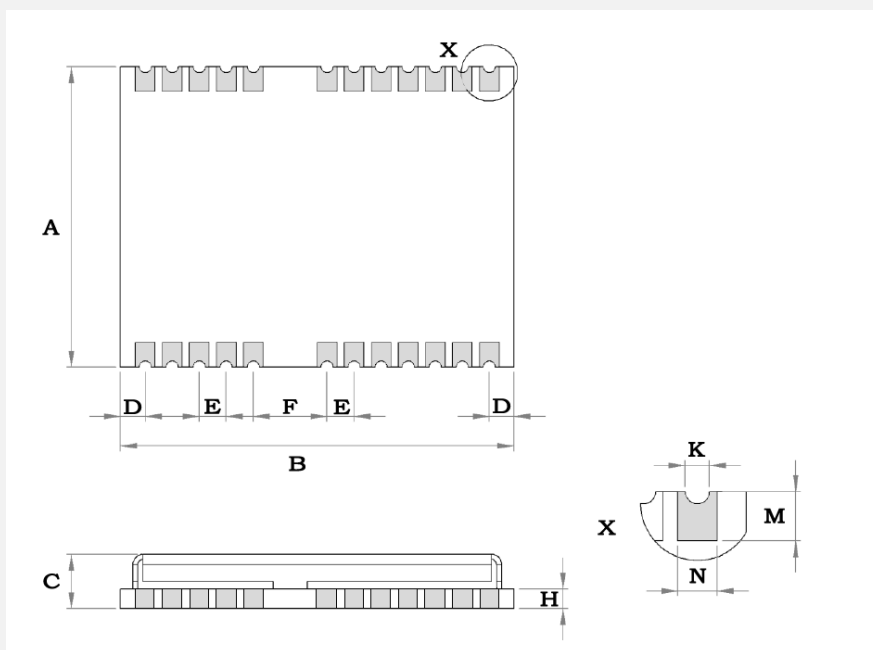

Figure 6 Dimensions

Table 12 Dimensions

Symbol	Min.(mm)	Typ.(mm)	Max.(mm)
A	12.0	12.2	12.4
B	15.8	16.0	16.2
C	2.2	2.4	2.6
D	0.9	1.0	1.3
E	1.0	1.1	1.2
F	2.9	3.0	3.1
H	--	0.8	--
K	0.4	0.5	0.6
M	0.8	0.9	1.0
N	0.7	0.8	0.9

6 REFERENCE DESIGN

6.1 Minimal design

This is a minimal design for a TAU1302 GNSS module. The 82nH inductor is used only when an active antenna is connected, and no need with a passive antenna. The characteristic impedance from RF_IN pin to the antenna connector should be 50Ω.

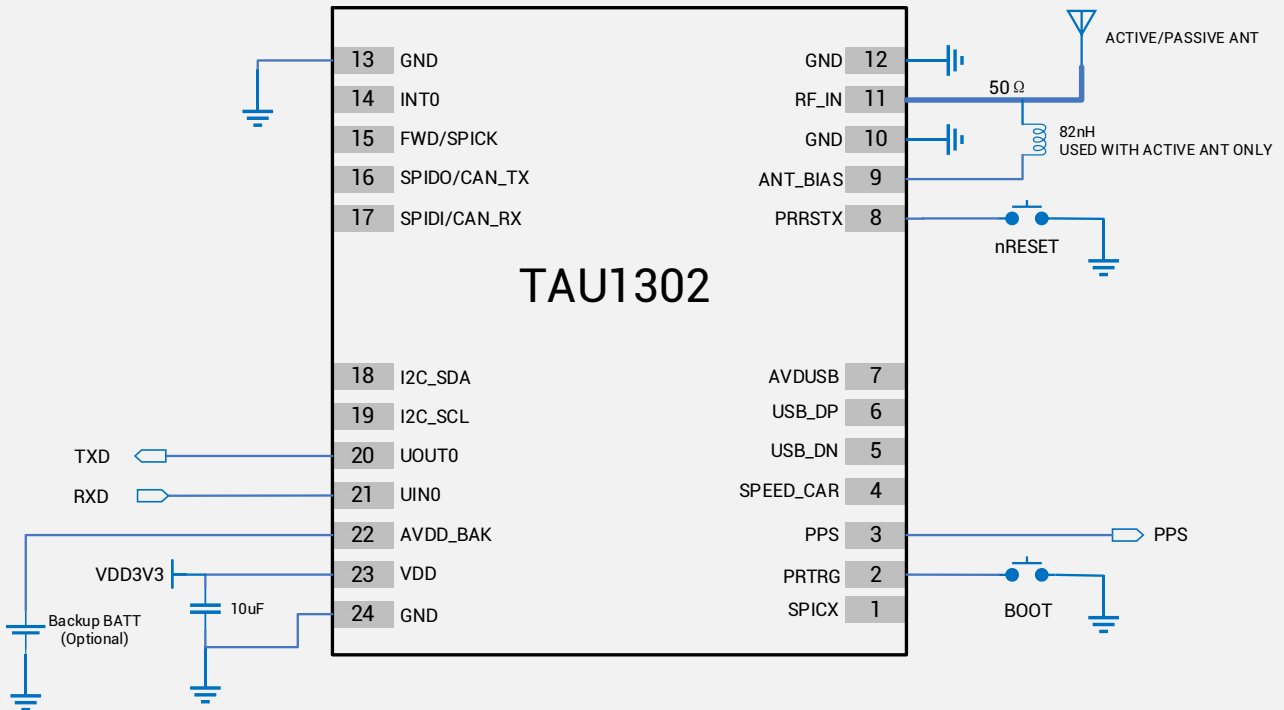

Figure 7 Minimal application diagram

6.2 PCB Footprint Reference

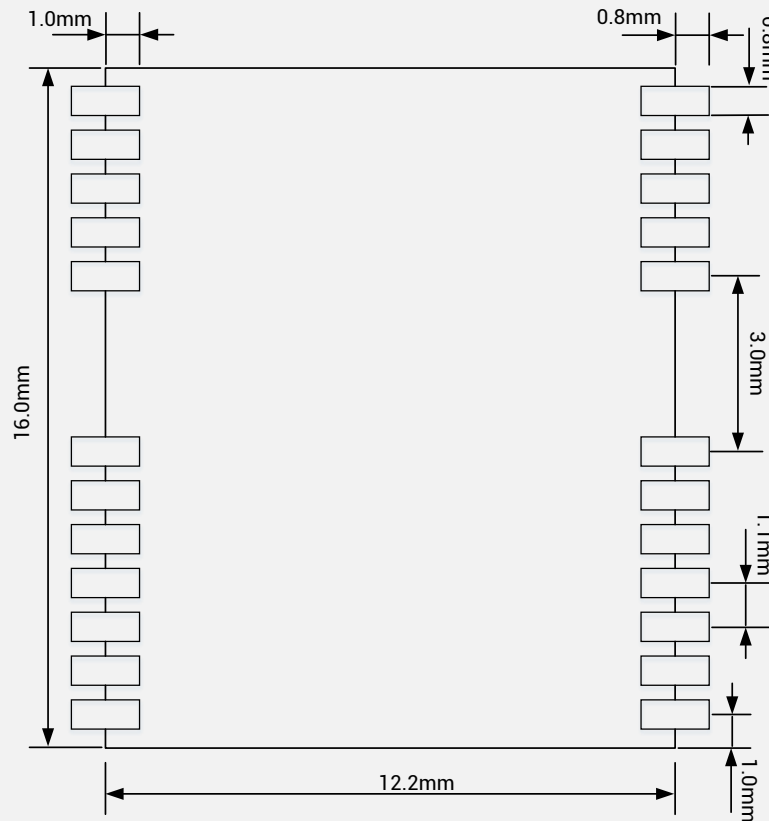

Figure 8 PCB Footprint Reference

6.3 Layout Notes

- (1) A decoupling capacitor should be placed close to VDD pin of the module, and the width of power routing should be more than 0.5mm.
- (2) The width of RF routing between RF port to antenna interface should be wider than 0.2mm. The characteristic impedance of RF routing between RF port to antenna interface should be controlled to 50Ω.
- (3) It is recommended that the routing from RF port to antenna interface refers to the second layer, and no routing are recommended on the layer.
- (4) Do not place the module close to any EMI source, like antenna, RF routing, DC/DC or power conductor, clock signal or other high-frequency switching signal, etc.





7 PRODUCT PACKAGING AND HANDLING

7.1 Packaging

7.1.1 Packaging Notes

TAU1302 is a Moisture Sensitive Device (MSD) and Electrostatic Sensitive Device (ESD). During the packing and shipping, it is strictly required to take appropriate MSD handling instructions and precautions. The table below shows the general packing hierarchy for the standard shipment.

Table 13 Packing hierarchy

Module	Reel	Sealed bag	Shipping carton
			

7.1.2 Tape and Reel

TAU1302 is delivered as hermetically sealed, reeled tapes in order to enable efficient production, production lot set-up and tear-down. The figure below shows the tape dimensions.

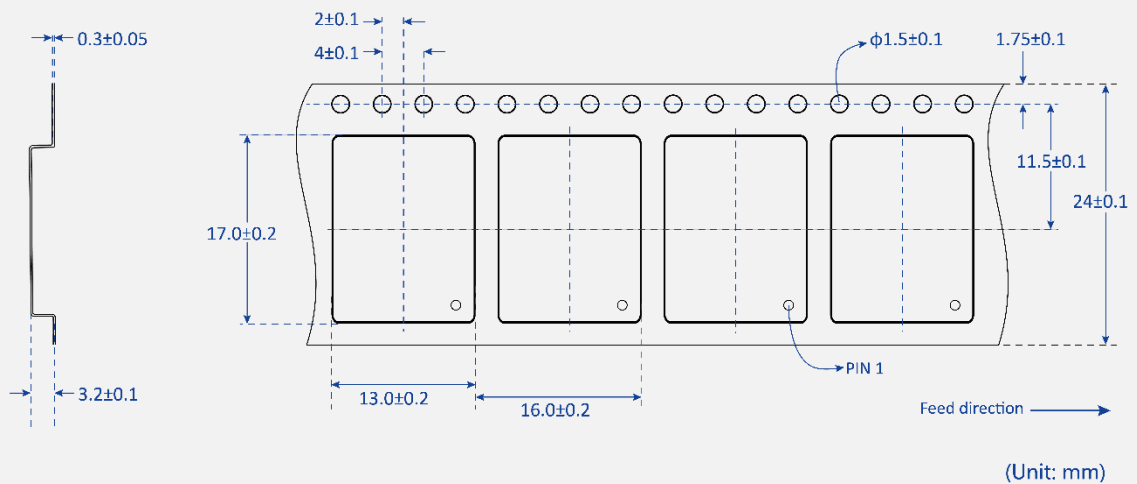
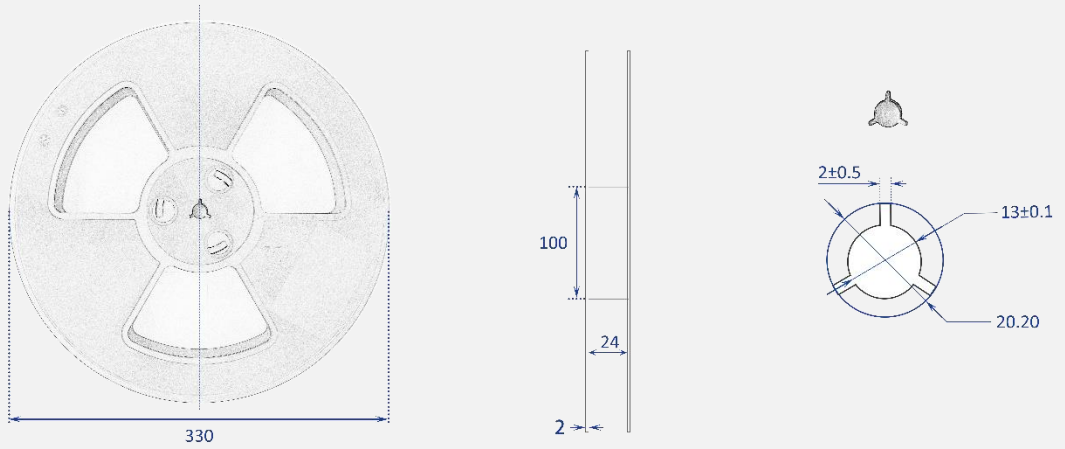

Figure 9 Tape dimensions

TAU1302 is deliverable in quantities of 1000pcs on a reel. The figure below shows the dimensions of reel for TAU1302.



(Unit: mm)

Figure 10 Reel dimensions

7.1.3 Shipment Packaging

The reels of TAU1302 are packed in the sealed bags and shipped by shipping cartons. Up to five sealed bags (5000pcs in total) can be packed in one shipping carton.

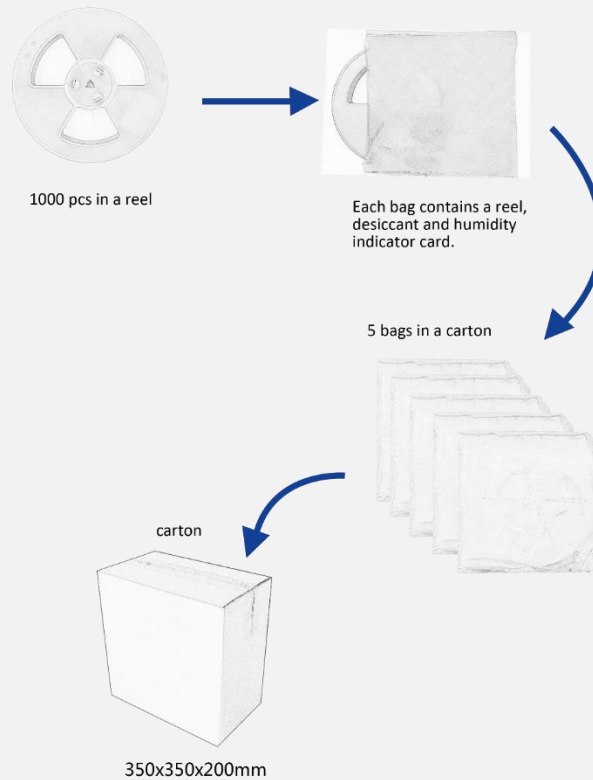

Figure 11 Packaging

7.2 Storage

In order to prevent moisture intake and protect against electrostatic discharge, TAU1302 is packaged together with a humidity indicator card and desiccant to absorb humidity.

7.3 ESD Handling

7.3.1 ESD Handling Precautions

TAU1302 which contains highly sensitive electronic circuitry is an Electrostatic-sensitive Device (ESD). Observe precautions for handling! Failure to observe these precautions may result in severe damage to the GNSS module!

- Unless there is a galvanic coupling between the local GND (i.e. the workbench) and the PCB GND, then the first point of contact when handling the PCB must always be between the local GND and PCB GND.
- Before mounting an antenna patch, connect ground of the device.
- When handling the RF pin, do not come into contact with any charged capacitors and be careful when contacting materials that can develop charges (e.g. patch antenna ~10 pF, coax cable ~50 – 80 pF/m, soldering iron, ...)
- To prevent electrostatic discharge through the RF input, do not touch any exposed antenna area. If there is any risk that such exposed antenna area is touched in non ESD protected work area, implement proper ESD protection measures in the design.
- When soldering RF connectors and patch antennas to the receiver's RF pin, make sure to use an ESD safe soldering iron (tip).



7.3.2 ESD protection measures

The GNSS positioning module is sensitive to static electricity. Whenever handling it, particular care must be exercised to reduce the risk of electrostatic charges. In addition to standard ESD safety practices, the following measures should be taken into account.

- Adds ESD Diodes to the RF input part to prevent electrostatics discharge.
- Do not touch any exposed antenna area.
- Adds ESD Diodes to the UART interface.

7.3.3 Moisture sensitivity level

The Moisture Sensitivity Level (MSL) of the GNSS module is MSL4.

8 LABELING AND ORDERING INFORMATION

Labeling and ordering information help customers get more about Allystar products.

8.1 Labeling

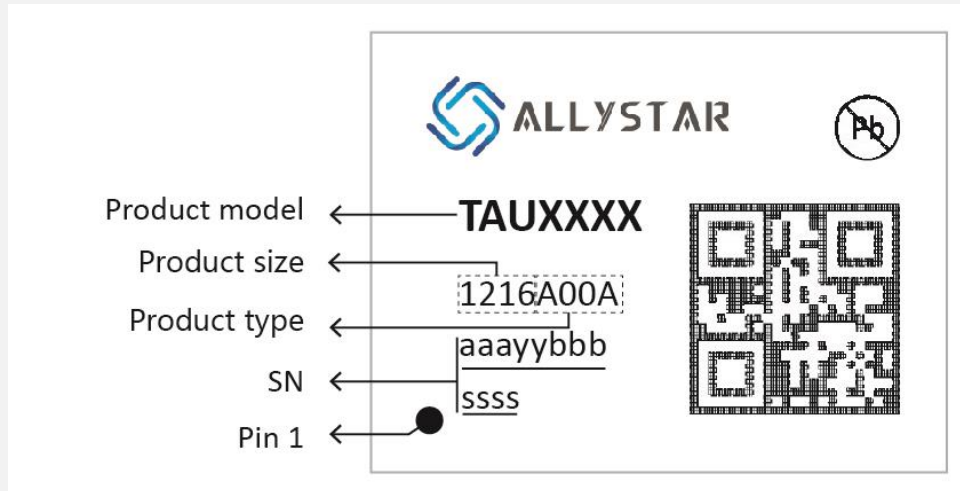

Table 14 Labeling content

Symbol	Explanation	Instance
TAUXXX	Product model	TAU1302
1216A00A	1216 represents the product size.	1216A00
	A00 means the product type.	
	Second A refers to sales area code. Different code for different sales area.	E (for Europe market)
aaayybbbssss	Serial number	355190010001

8.2 Ordering info

Table 15 Ordering codes

Ordering No.	Product
TAU1302-1216A00E	Concurrent GNSS LCC Module, TCXO, ROM, 12.2*16mm, 1000 pieces/reel, Europe market.
TAU1302-1216A00H	Concurrent GNSS LCC Module, TCXO, ROM, 12.2*16mm, 1000 pieces/reel, India market.
TAU1302-1216A00R	Concurrent GNSS LCC Module, TCXO, ROM, 12.2*16mm, 1000 pieces/reel, Russia market.

9 RELATED DOCUMENTS

- [1] Satrack User Manual
- [2] Allystar Common Commands
- [3] Recommended Reflow Profile
- [4] GNSS_Protocol_Specification

10 REVISION HISTORY

Revision	Date	Reviser	Status / Comments
V1.0	2019-09-09	Vita Wu	First released
V1.1	2019-10-14	Vita Wu	Updates dimensions; Adds packaging info; Updates backup voltage descriptions and reference design diagram. Adds PCB packaging info in Section 6.
V1.2	2019-12-9	Vita Wu	Updates antenna gain in Section 4.2; Updates Section 6.3;
V1.3	2020-02	Vita Wu	Updates Galileo E6 support in section 1.6 GNSS Reception;
V1.4	2020-12	Vita Wu	Deletes SBAS support. Fixes I/O type of I2C pin to be I/O. Fixes I/O type of INT0 pin to be I. Updates MSL. Updates 39nH inductor to be 82nH in minimal design. Fixes I _{CCRX2} power consumption to be 34mA in Table 9. Improves mechanical specification. Updates description about short circuit protection in Section 4.3. Improves layout notes in Section 6.3. Clarifies power on/off sequence in Section 4.2. Deletes 1K resistor in the minimal design diagram. Localization. Improves wording.
V1.5	2021-07	Vita Wu	Adds labeling and ordering info. Details default settings. Adds related document list. Adds document info section. Updates operative VDD to 2.0 ~3.6V. Adds ANT_BIAS output current and voltage.
V1.6	2021-11	Cao Min	Upgrades conditions for supporting RF modes Upgrades headquarters address



www.allystar.com



info.gnss@allystar.com



Headquarters

Allystar Technology (Shenzhen) Co., Ltd.

Address: 201-2, 2F, Tower F, Xinghe World, No.1, Yabao Road, LongGang District, Shenzhen City, Guangdong Province, China.

Calgary Office

Allystar Technology (Canada) Ltd.

Address: Unit 288, 3553 31 Street NW Calgary, Alberta, Canada T2L 2K7

