

- RF Filter Designed for Front End GPS Applications
- Low Insertion Loss
- Improved Rejection
- 2.0 x 1.6 mm Surface-Mount Case
- Complies with Directive 2002/95/EC (RoHS)
- AEC-Q200 Qualified

RoHS
Compliant

SF2460H

**1254.15 MHz
SAW Filter**

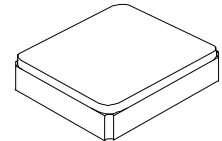

SM2016-4

Absolute Maximum Ratings

Rating	Value	Units
Input Power Level	+10	dBm
DC Voltage	3	VDC
Operable Temperature Range	-40 to +105	°C
Specification Temperature Range	-40 to +105	°C
Storage Temperature Range	-40 to +105	°C
Moisture Sensitivity Level	1	MSL
Maximum Soldering Profile	265°C for 10 s	

Electrical Characteristics

Item	Unit	Min.	Typ.	Max.	Note
Center frequency Fc	MHz	-	1254.15	-	-
Insertion Loss (1219.8~1288.5 MHz) IL	dB	-	4	5.0	-40~+85°C
Insertion Loss (1219.8~1288.5 MHz) IL	dB	-	4	5.2	-40~+105°C
Amplitude Ripple (1219.8~1288.5 MHz)	dB	-	1.1	2.0	-
Group Delay Ripple (1219.8~1288.5 MHz)	ns	-	4	20	-
Return Loss (1219.8~1288.5 MHz)	dB	6.5	7.5	-	-
Attenuation (Reference level from 0 dB)					
800 ~ 920 MHz	dB	37	41	-	-
1710 ~ 1780 MHz	dB	39	43	-	-
1850 ~ 1910 MHz	dB	39	42	-	-
1920 ~ 1980 MHz	dB	40	44	-	-
2400 ~ 2500 MHz	dB	41	46	-	-
Temperature coefficient of frequency	ppm/k	-	-80	-	-

Single-ended Input / Output Impedance Match	No matching network required for operation at 50 ohms
Case Style	SM2016-4
Lid Symbolization (Y=year, W=week)	A2, <u>YW</u>

 **CAUTION: Electrostatic Sensitive Device. Observe precautions for handling.**

NOTES:

1. The design, manufacturing process, and specifications of this device are subject to change.
2. US or International patents may apply.
3. RoHS compliant from the first date of manufacture.

Measurement Circuit

Connections	Terminal
Input	1
Output	3
Ground	2, 4

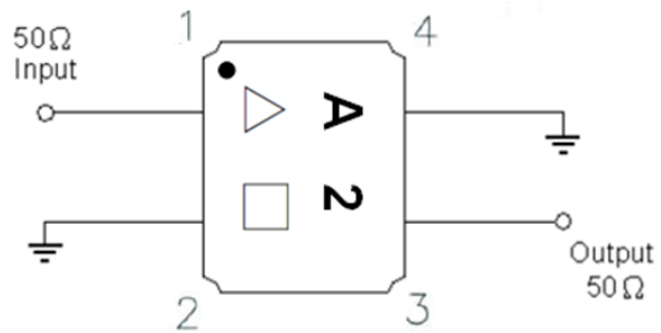

Frequency Characteristics

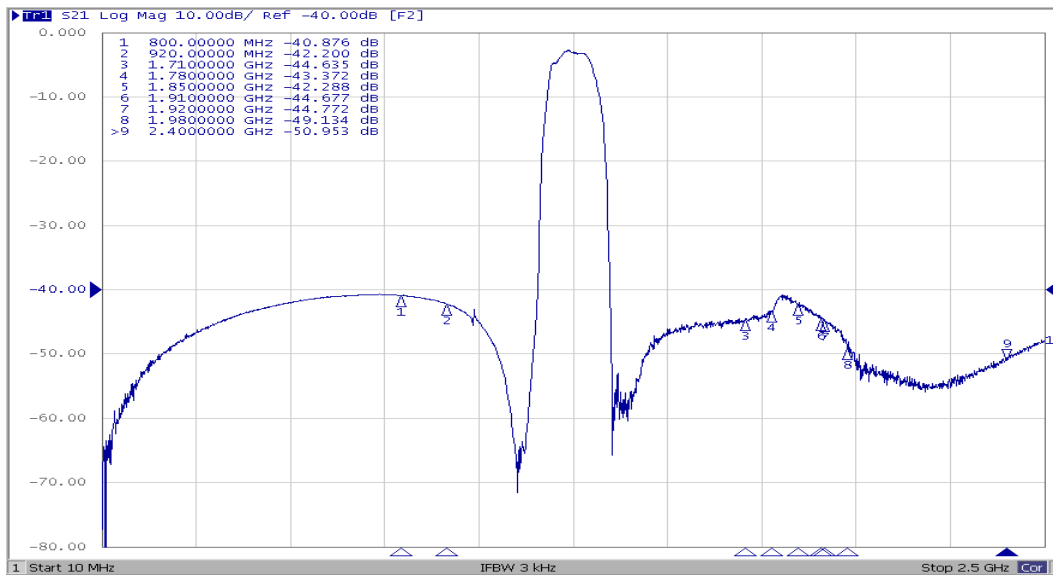
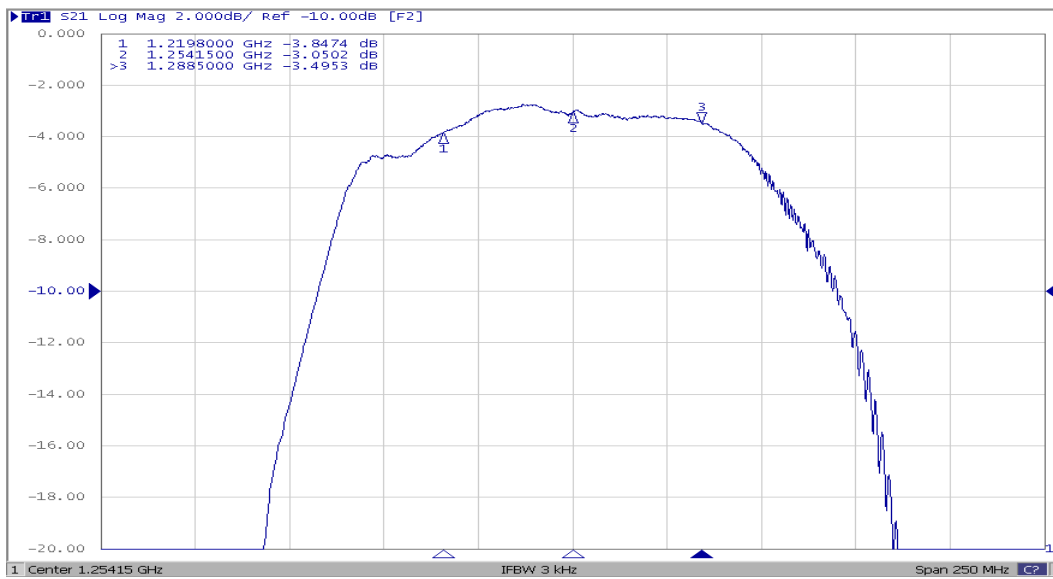

Group Delay

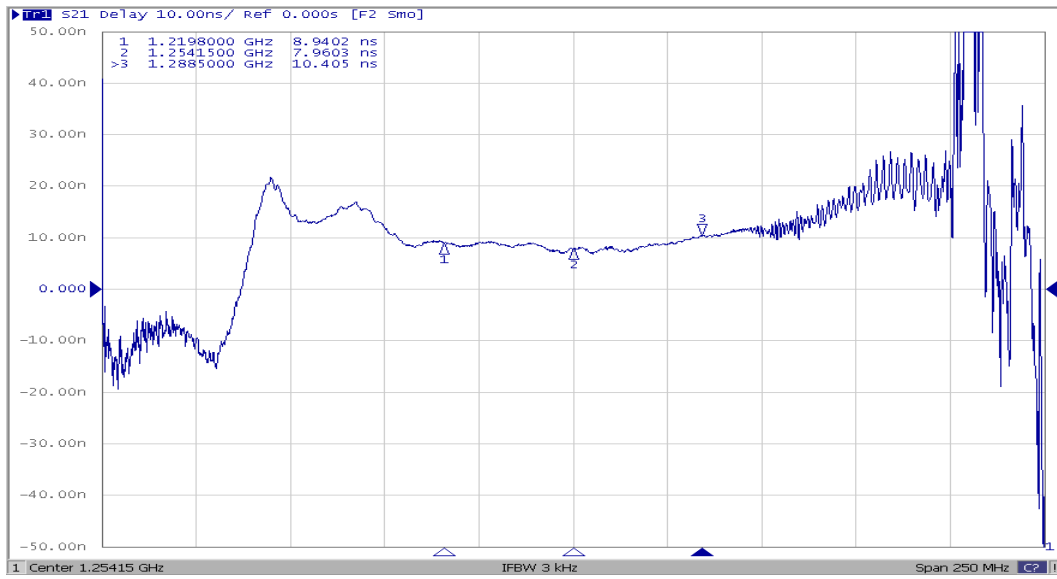

Reflection Functions

S11

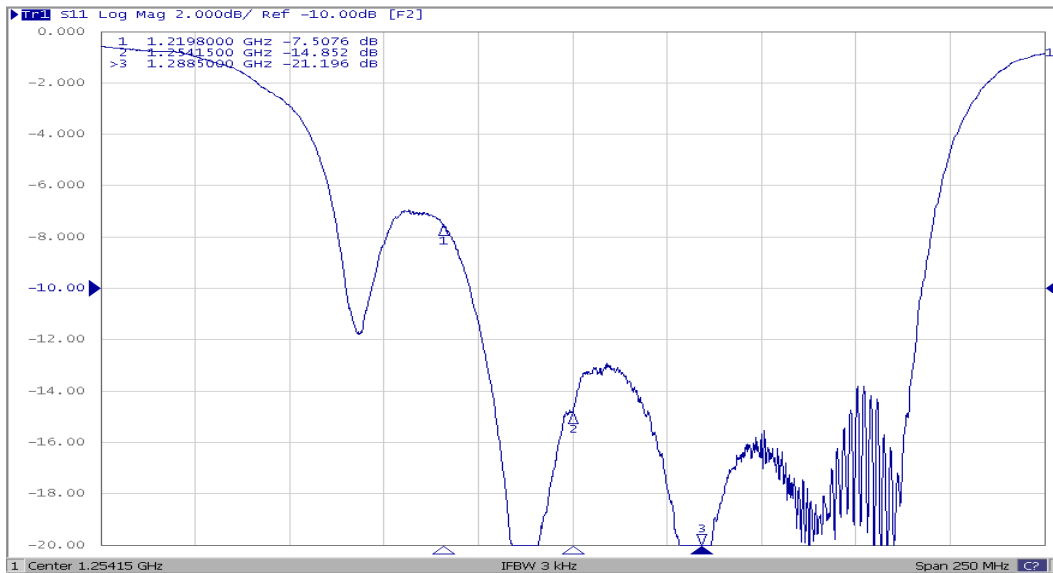

S22

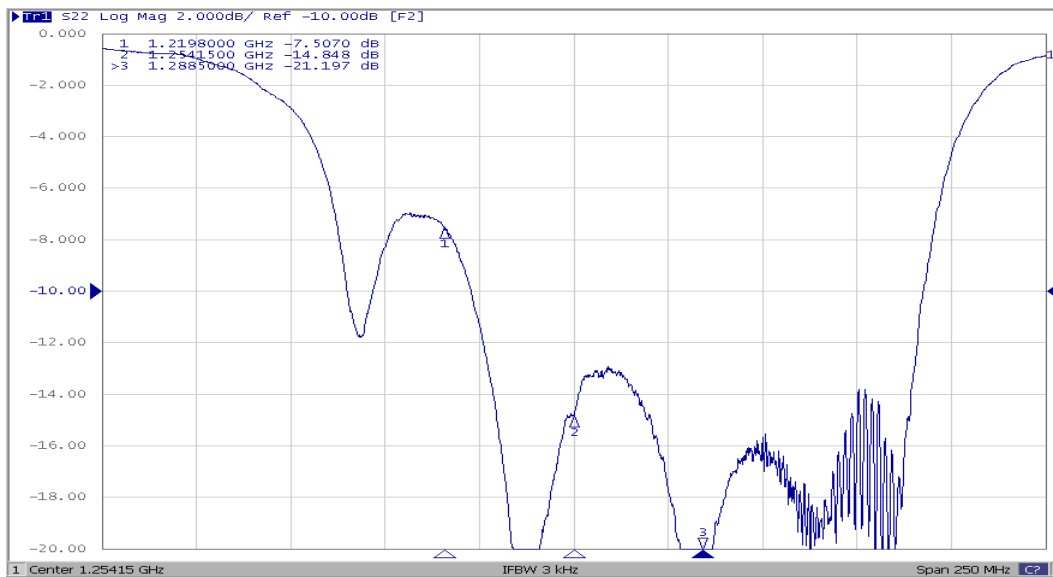

Outline Drawing

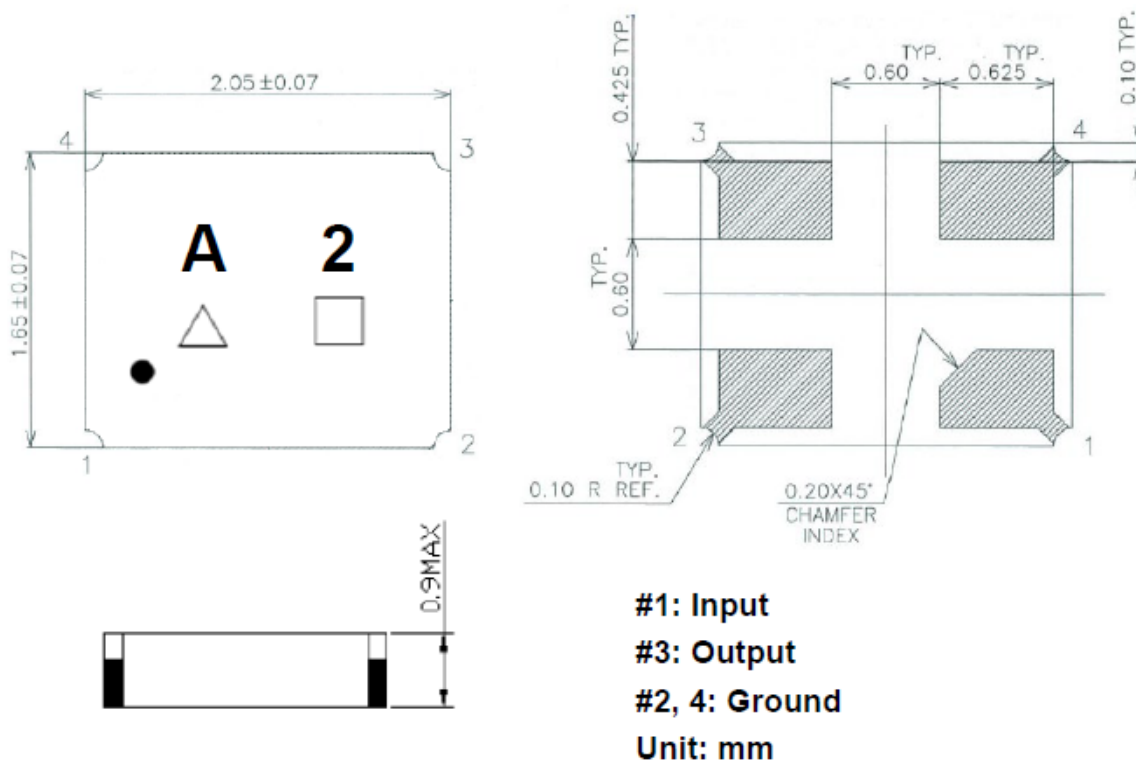

△: Year Code (2020->0, 2021->1, ..., 2029->9)

□: Date Code (Follow the table from planner each year)

WK01	WK02	WK03	WK04	WK05	WK06	WK07	WK08	WK09	WK10	WK11	WK12	WK13
A	B	C	D	E	F	G	H	I	J	K	L	M
WK14	WK15	WK16	WK17	WK18	WK19	WK20	WK21	WK22	WK23	WK24	WK25	WK26
N	O	P	Q	R	S	T	U	V	W	X	Y	Z
WK27	WK28	WK29	WK30	WK31	WK32	WK33	WK34	WK35	WK36	WK37	WK38	WK39
a	b	c	d	e	f	g	h	i	j	k	l	m
WK40	WK41	WK42	WK43	WK44	WK45	WK46	WK47	WK48	WK49	WK50	WK51	WK52
n	o	p	q	r	s	t	u	v	w	x	y	z

PCB Footprint

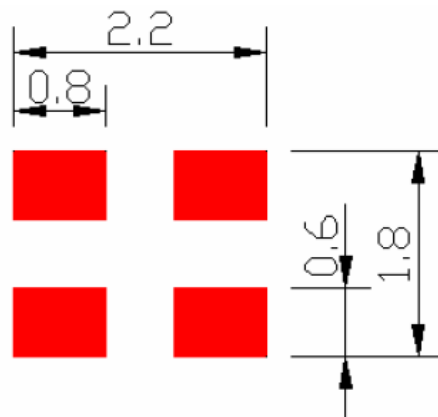

Packing

Tape and Reel Standard per ANSI/EIA-481

Reel Count:
7" = 2000
13" = 10,000

Reel Dimension

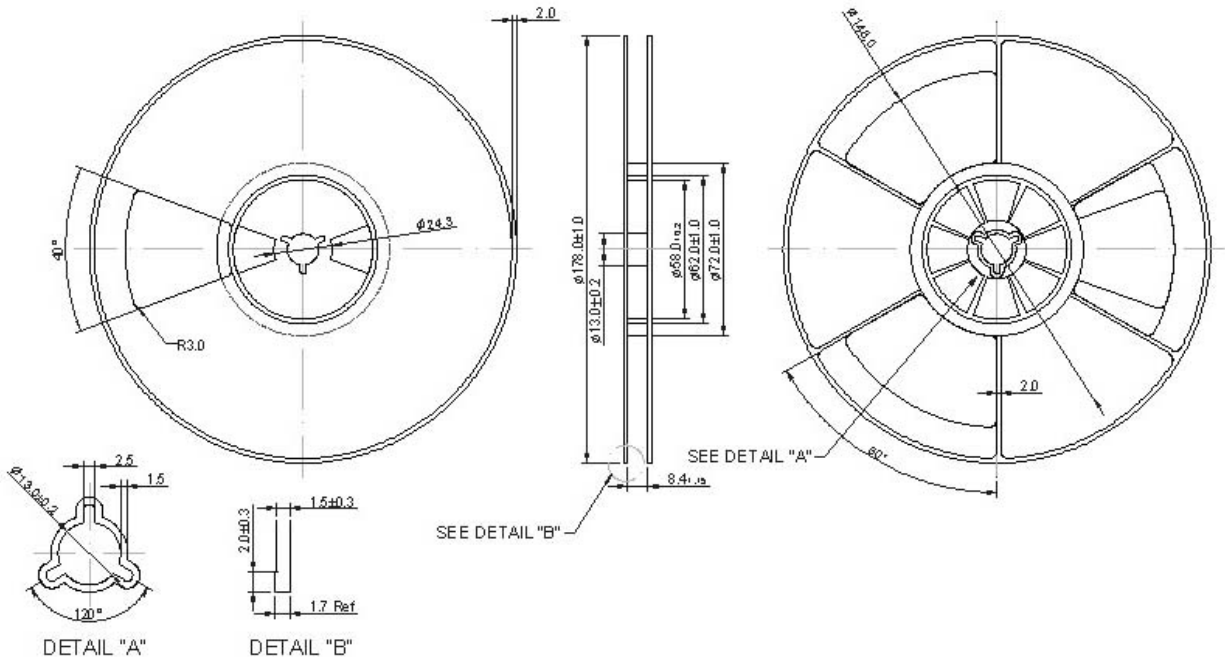

Tape Dimension

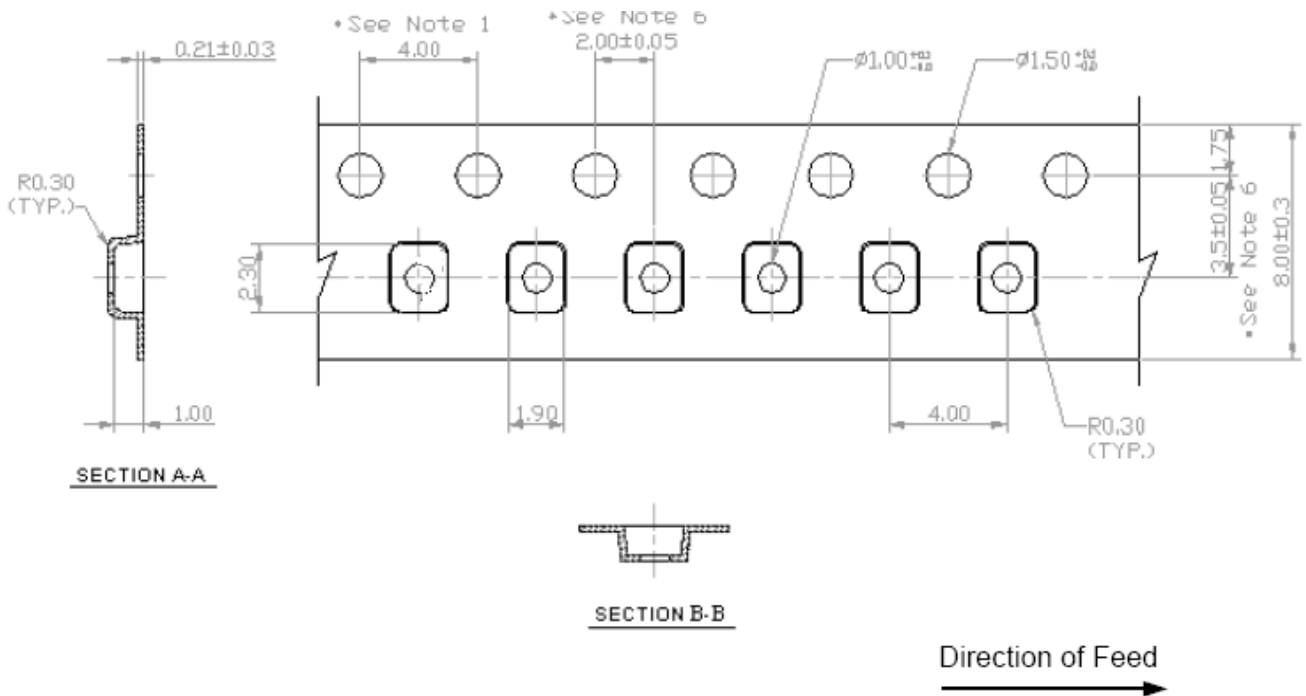

Recommended Reflow Profile

1. Preheating shall be fixed at 150~180°C for 60~90 seconds.
2. Ascending time to preheating temperature 150°C shall be 30 seconds min.
3. Heating shall be fixed at 220°C for 50~80 seconds and at 260°C +0/-5°C peak (10 seconds).
4. Time: 5 times maximum.

