

nPM1100

Product Specification

v1.0

nPM1100

nPM1100 is an integrated Power Management IC (PMIC) with a linear-mode lithium-ion/lithium-polymer battery charger in a compact 2.1x2.1 mm WLCSP package. It has a highly efficient, dual-mode configurable output DC/DC buck regulator.

nPM1100 is an extremely compact PMIC device, created for space constrained applications with a small lithium-ion or lithium-polymer battery. It is compatible with all nRF52 and nRF53 Series SoCs and supports charging batteries at up to 500 mA through USB, and also delivers up to 150 mA of current to power external components with regulated voltage.

A minimum of five passive components are required for operation and the device functions without a control interface. It is the perfect companion for nRF52 and nRF53 multiprotocol SoCs in battery powered designs. Low quiescent current (IQ) extends battery life during shipping and storage with Ship mode, or in operation using auto-controlled hysteretic buck mode for high efficiency down to 1 μ A loads. Charge and error indication LED drivers are built in. Charge profile limits are configurable and VBUS current limits can be fixed or auto-controlled with on-chip USB port detection.

- Ultra-high efficiency prolongs battery life or allows for use of smaller and less costly batteries
- Small solution size leaves space for additional features without increasing product size
- No software control
- Automatic USB port detection minimizes development time

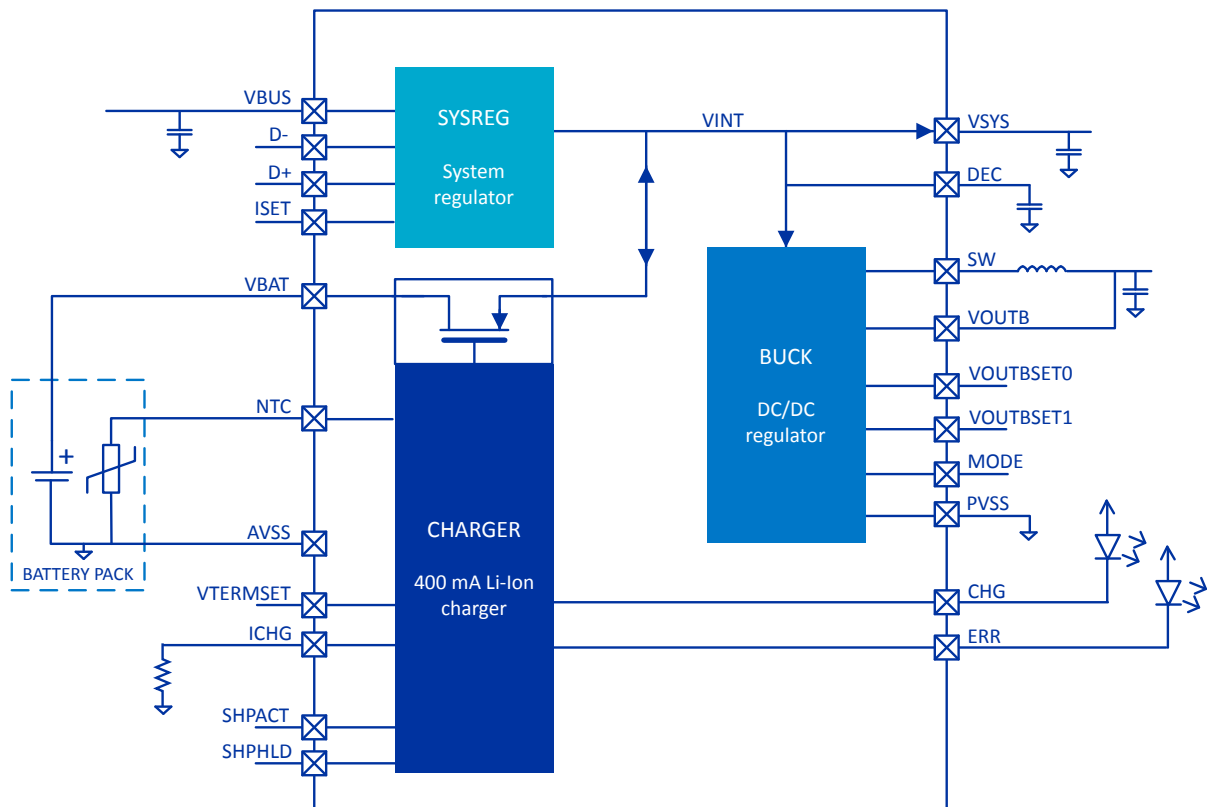

Figure 1: nPM1100 block diagram

Feature list

Features:

- 400 mA linear battery charger
 - Linear charger for lithium-ion/lithium-polymer batteries
 - Adjustable charge current from 20 mA to 400 mA
 - Selectable termination voltage of 4.1 V or 4.2 V
 - Automatic trickle, constant current, and constant voltage charging
 - Battery thermal protection
 - Discharge current limitation
 - JEITA compliant
- Li-ion/Li-polymer USB battery charger with a high efficiency buck regulator
- 800 nA - Typical quiescent current
- 460 nA - Shipping mode quiescent current
- Thermal protection
- Input regulator
 - USB compatible current limit of 100 mA and 500 mA
 - 4.1 V to 6.7 V input voltage range for normal operation
 - 20 V overvoltage protection
 - Reverse current protection
 - 3.0 V to 5.5 V system voltage output
 - USB port detection supporting the following types:
 - SDP
 - CDP/DCP
- 1.8 V to 3.0 V, 150 mA step-down buck regulator
 - Step-down buck regulator with up to 92% efficiency
 - Automatic transition between hysteretic and pulse width modulation (PWM) modes
 - Forced PWM mode for clean power operation
 - Pin-selectable output voltage (1.8 V, 2.1 V, 2.7 V, 3.0 V)
 - Soft start-up
- LED drivers for charger state indication
 - 5 mA low side LED driver for charging indication
 - 5 mA low side LED driver for error indication
- 2.3 V to 4.35 V battery operating input range
- 2.1x2.1 mm WLCSP package
 - Suitable for two layer PCB design

Applications:

- Advanced wearables
 - Health/fitness sensor and monitor devices
- Advanced computer peripherals and I/O devices
 - Mouse
 - Keyboard
 - Multi-touch trackpad
- Interactive entertainment devices
 - Remote controls
 - Gaming controllers

Contents

nPM1100	ii
Feature list	iii
1 Revision history	6
2 About this document	7
2.1 Document status	7
2.2 Core component chapters	7
3 Product overview	8
3.1 Block diagram	8
3.1.1 In circuit configurations	8
3.2 System description	9
3.3 Power-on reset (POR) and brownout reset (BOR)	10
3.4 DPPM — Dynamic power-path management	10
3.5 Using Ship mode	10
3.6 Thermal protection	11
3.7 Battery considerations	11
3.8 Charging and Error LED drivers	11
3.9 System electrical parameters	11
3.10 System efficiency	12
4 Absolute maximum ratings	13
5 Recommended operating conditions	14
5.1 Dissipation ratings	14
5.2 WLCSP light sensitivity	14
6 Core components	15
6.1 SYSREG — System regulator	15
6.1.1 USB port detection and VBUS current limiting	15
6.1.2 SYSREG resistance and output voltage	16
6.1.3 VBUS overvoltage and undervoltage protection	16
6.1.4 VBUS disconnect	16
6.1.5 Electrical parameters	16
6.1.6 Electrical characteristics	17
6.2 CHARGER — Battery charger	19
6.2.1 Charging cycle	19
6.2.2 Battery detection and UVLO	20
6.2.3 Termination voltage (VTERMSET)	21
6.2.4 Termination and trickle charge current	21
6.2.5 Charge current limit (ICHG)	21
6.2.6 Battery thermal protection using NTC thermistor (NTC)	21
6.2.7 Charger thermal regulation	22
6.2.8 Charger error conditions	22
6.2.9 Charging indication (CHG) and charging error indication (ERR)	23
6.2.10 DPPM — Dynamic power-path management	23

6.2.11 Electrical parameters	24
6.2.12 Electrical characteristics	26
6.3 BUCK — Buck regulator	28
6.3.1 Output voltage selection (VOUTBSET0, VOUTBSET1)	29
6.3.2 BUCK mode selection (MODE)	29
6.3.3 Component selection	29
6.3.4 Electrical parameters	30
6.3.5 Electrical characteristics	31
7 Application	39
7.1 Schematic	39
7.2 Supplying from BUCK	39
7.3 USB port negotiation	40
7.4 CHG and ERR	40
7.5 Termination voltage and current	40
7.6 NTC configuration	40
7.7 Ship mode	40
7.8 Battery monitoring and low battery indication	41
8 Hardware and layout	42
8.1 Ball assignments	42
8.2 Mechanical specifications	43
8.2.1 WLCSP 2.075x2.075 mm package	43
8.3 Reference circuitry	44
8.3.1 Configuration 1	45
8.3.2 Configuration 2	46
8.3.3 Configuration 3	47
8.3.4 PCB guidelines	48
8.3.5 PCB layout example	48
9 Ordering information	52
9.1 IC marking	52
9.2 Box labels	52
9.3 Order code	53
9.4 Code ranges and values	54
9.5 Product options	55
10 Legal notices	57

1 Revision history

Date	Version	Description
May 2021	1.0	First release

2 About this document

This document is organized into chapters that are based on the modules available in the IC.

2.1 Document status

The document status reflects the level of maturity of the document.

Document name	Description
Objective Product Specification (OPS)	Applies to document versions up to 1.0. This document contains target specifications for product development.
Product Specification (PS)	Applies to document versions 1.0 and higher. This document contains final product specifications. Nordic Semiconductor ASA reserves the right to make changes at any time without notice in order to improve design and supply the best possible product.

Table 1: Defined document names

2.2 Core component chapters

Every core component has a unique capitalized name or an abbreviation of its name, e.g. LED, used for identification and reference. This name is used in chapter headings and references, and it will appear in the C-code header file to identify the component.

The core component instance name, which is different from the core component name, is constructed using the core component name followed by a numbered postfix, starting with 0, for example, LED0. A postfix is normally only used if a core component can be instantiated more than once. The core component instance name is also used in the C-code header file to identify the core component instance.

The chapters describing core components may include the following information:

- A detailed functional description of the core component
- Register configuration for the core component
- Electrical specification tables, containing performance data which apply for the operating conditions described in [Recommended operating conditions](#) on page 14.

3 Product overview

This chapter contains an overview of the main features found in nPM1100.

3.1 Block diagram

The block diagram illustrates the overall system.

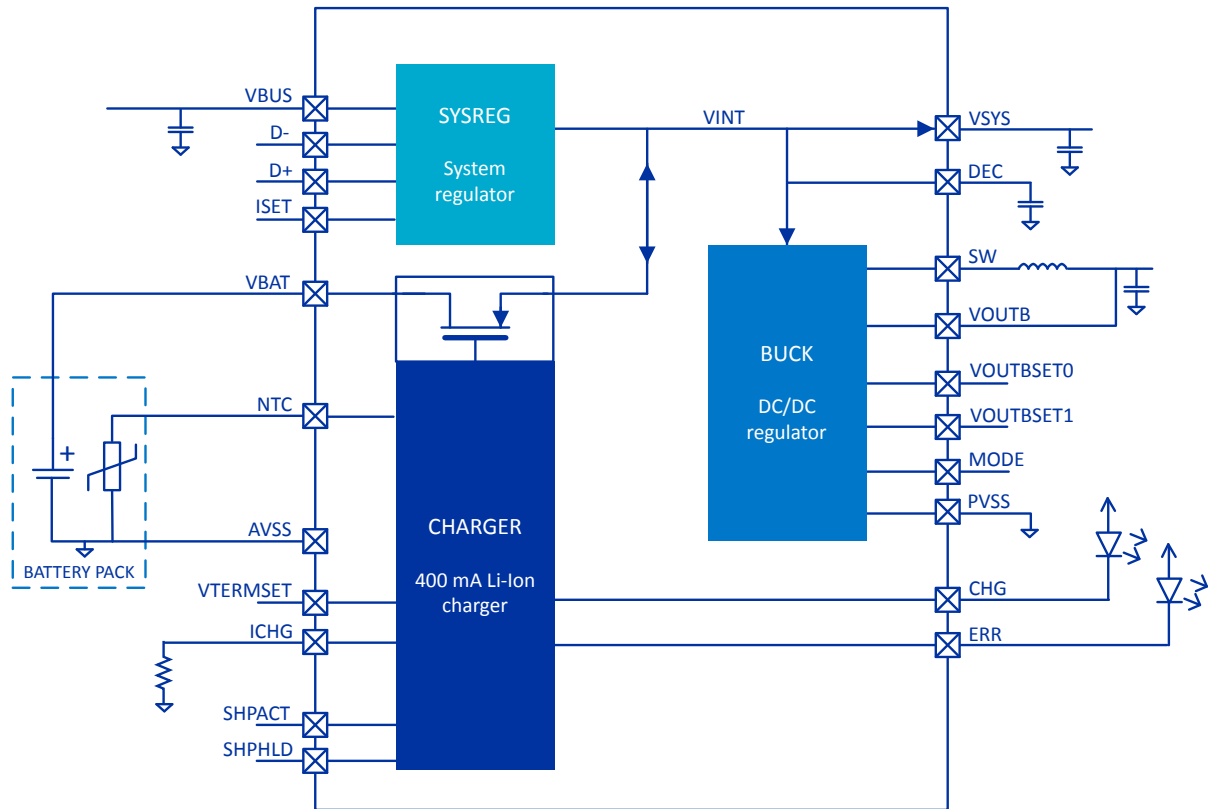

Figure 2: Block diagram

3.1.1 In circuit configurations

The device is configurable for different applications and battery characteristics via input pins.

Static input pins must be configured before power-on reset. Dynamic input pins may be modified during operation under conditions described in references.

Pin	Function	Input type	Usage reference
VTERMSET	Sets termination voltage Battery dependent	Static (H/L)	Termination voltage (VTERMSET) on page 21
ICHG	Charge current limit	Static (resistor)	Charge current limit (ICHG) on page 21
ISET	VBUS current limit	Dynamic (H/L)	USB port detection and VBUS current limiting on page 15
MODE	BUCK PWM mode override	Dynamic (H/L)	BUCK mode selection (MODE) on page 29
VOUTBSETx	Two pin VOUTB voltage configuration	Static (H/L)	Output voltage selection (VOUTBSET0, VOUTBSET1) on page 29
SHPACT	Enables Ship mode	Dynamic (H/L) ¹	Using Ship mode on page 10
SHPHLD	Disables Ship mode	Dynamic (H/L) ¹	Using Ship mode on page 10

Table 2: In circuit configurations

¹These pins are level and hold-time controlled.

3.2 System description

The device has the following core components that are described in detail in the respective chapters.

- [SYSREG — System regulator](#) on page 15
- [CHARGER — Battery charger](#) on page 19
- [BUCK — Buck regulator](#) on page 28

The system regulator (SYSREG) is a 5 V LDO supplied by **VBUS**. It generates VINT when enabled. VINT is the internal supply for the device and available on an external pin, **VSYS**. SYSREG supports a wide operating voltage range on **VBUS**, tolerates transient voltages up to 20 V, and implements overvoltage protection. SYSREG also implements configurable current limiting from **VBUS**, and USB port detection. When **VBUS** is disconnected, SYSREG ensures the device enters Ultra-Low Power mode to minimize quiescent current. Reverse current protection is enabled when $VBUS < VBAT$. See [SYSREG — System regulator](#) on page 15 for more information and electrical parameters.

The battery charger (CHARGER) is a JEITA compatible linear battery charger for Li-ion/Li-poly batteries. CHARGER controls the charge cycle using a standard Li-ion charge profile. CHARGER implements dynamic power-path management regulating current in and out of the battery, depending on system requirements. Charge current and charge termination voltage can be set via the **ICHG** and **VTERMSET** pins respectively. LED drivers for charging indication and charging error indication are implemented in CHARGER. See [CHARGER — Battery charger](#) on page 19 for more information and electrical parameters.

The buck regulator (BUCK) is a step-down DC/DC regulator with PWM and hysteretic modes with automatic control for optimum efficiency and manual enable of PWM mode to reduce voltage ripple and inductive interference if needed. The output voltage is pin configurable (through **VOUTSET0** and

VOUTSET1) for different application circuit requirements. BUCK is supplied by VINT (from SYSREG or the battery). See [BUCK — Buck regulator](#) on page 28 for more information and electrical parameters.

The device also features Ship mode, the lowest quiescent current state. It disconnects the battery from the system and reduces the quiescent current of the device to extend battery life when products are in storage. See [Using Ship mode](#) on page 10 and [Charging and Error LED drivers](#) on page 11 for more information.

3.3 Power-on reset (POR) and brownout reset (BOR)

When one of the following conditions are met, a power-on reset (POR) occurs.

- **VBUS** voltage rises above $VBUS_{POR}$
- **VBAT** voltage rises above $VBAT_{POR}$

$VBAT_{POR}$ has a minimum and maximum range. To ensure the device exits reset, the voltage should be above the maximum of the parameter.

When both of the following conditions are met, a brownout reset (BOR) occurs.

- **VBUS** voltage falls below $VBUS_{BOR}$
- **VBAT** voltage falls below $VBAT_{BOR}$

BOR may occur if both supply voltages are below the maximum of the parameter range. BOR occurs if both supply voltages are below the minimum of the parameter range.

The device is held in reset, or System OFF, when both supply voltages **VBAT** and **VBUS** are below minimum thresholds.

3.4 DPPM — Dynamic power-path management

Dynamic power-path management (DPPM) is a feature that regulates internal voltage (VINT) as system load (I_{SYS}) changes to maintain supply to the application circuit (supplied by the **VSYS** and **VOUTB** pins).

CHARGER applies DPPM during charging, after charging completes, or when the **VBUS** pin is disconnected, to dynamically control current in and out of the battery. See [DPPM — Dynamic power-path management](#) on page 23.

3.5 Using Ship mode

Ship mode isolates the battery, reducing quiescent current.

To enter Ship mode, **SHPACT** must be set high for a minimum period of $t_{activeToShip}$ when **VBUS** is disconnected and **SHPHLD** held high (V_{IH}). **SHPACT** has an internal pull-down resistor. **SHPACT** can be connected to a microcontroller GPIO (using logic levels in the range V_{IL} and V_{IH}) or to a PCB test pin for activation at the end of production.

Note: **VBUS** must be discharged to below minimum level $VBUS_{MIN}$ which may require waiting for any capacitive discharge before activating **SHPACT**.

There are two ways to exit Ship mode. Either connect the USB (**VBUS**) or set **SHPHLD** low for a minimum period of $t_{shipToActive}$. The battery supply (**VBAT**) is used to hold **SHPHLD** high through a weak pull-up resistor when Ship mode is enabled. A circuit to pull **SHPHLD** down is optional (see the Button switch shown in the following figure). If no pull-down circuit is present, Ship mode is exited when **VBUS** is connected.

If Ship mode is not required, then **SHPACT** and **SHPHLD** pins may be tied to **AVSS**.

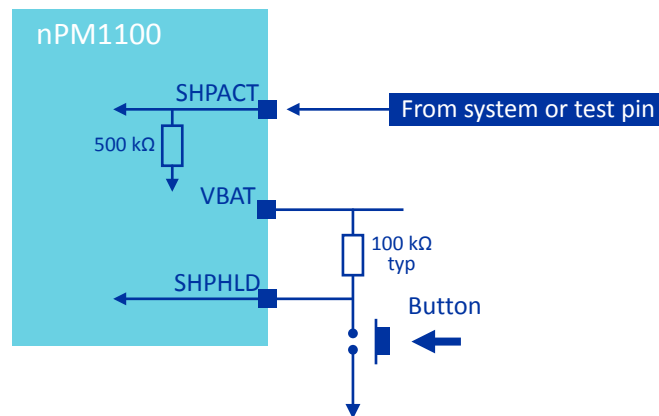

Figure 3: A typical configuration for Ship mode

3.6 Thermal protection

The device implements thermal regulation based on battery temperature, see [Battery thermal protection using NTC thermistor \(NTC\)](#) on page 21 and [Charger thermal regulation](#) on page 22.

In addition to battery thermal protection and charger thermal regulation, a global thermal shutdown based on die temperature is implemented when die temperature exceeds the operating temperature range, see [TSD](#). All device functions are disabled in thermal shutdown. The device functions are re-enabled when the temperature is sufficiently reduced according to a hysteresis TSD_{HYST} .

3.7 Battery considerations

The charger can only be used with Li-ion/Li-poly rechargeable batteries.

Battery packs connected to the **VBAT** pin must contain the following protection circuitry:

- Overcharge protection
- Undervoltage protection
- Overcurrent discharge fuse
- Thermal fuse to protect from overtemperature (if NTC thermistor is not present)

3.8 Charging and Error LED drivers

CHARGER controls the **CHG** and **ERR** pins, which are used to drive LEDs and/or signal status to an external circuit.

See [Charging indication \(CHG\)](#) and [charging error indication \(ERR\)](#) on page 23 for more information.

3.9 System electrical parameters

Symbol	Description	Min.	Typ.	Max.	Unit
$I_{Q_{SHIP}}$	Ship mode quiescent current	-	460	-	nA
$I_{Q_{BAT}}$	Quiescent current, battery operation, no load, MODE = LOW, VBUS disconnected	-	800	-	nA
TSD	Thermal shutdown threshold	-	120	-	°C
TSD _{HYST}	Thermal shutdown hysteresis	-	10	-	°C
V _{IH}	Input HIGH	1.1	-	VINT	V
V _{IL}	Input LOW	0	-	0.4	V
R _{SHPACT}	Internal resistance between SHPACT and AVSS		500		kΩ
t _{activeToShip}	Duration SHPACT must be held high to enable Ship mode	200			ms
t _{shipToActive}	Duration SHPHLD must be held low to disable Ship mode	200			ms

Table 3: System electrical parameters

3.10 System efficiency

Described here is the characterization of the power path from the battery supply (**VBAT**) to the BUCK output (**VOUSB**) under different battery voltages, output voltages, and load current conditions.

In the following figure, the load current is swept from 1 μ A to 150 mA and back to capture mode change hysteresis.

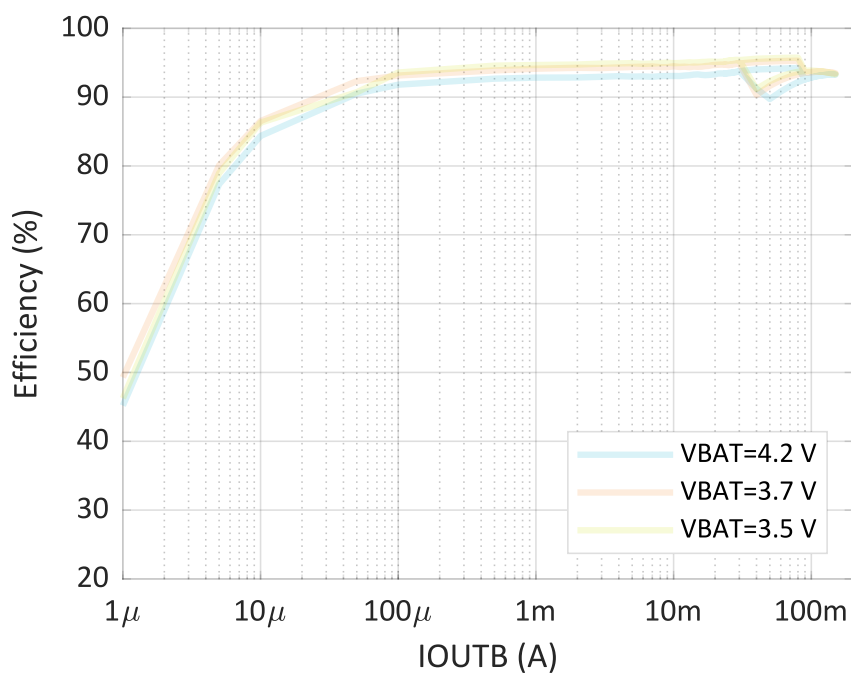
Figure 4: V_{OUTB} = 3.0 V system efficiency, MODE=AUTO

4 Absolute maximum ratings

Maximum ratings are the extreme limits to which the chip can be exposed for a limited amount of time without permanently damaging it. Exposure to absolute maximum ratings for prolonged periods of time may affect the reliability of the device.

Pin	Note	Min.	Max.	Unit
VBUS	Power	-0.3	20	V
VBAT	Power	-0.3	5.5	V
VSYS, DEC, SW		-0.3	5.5	V
AVSS, PVSS	Power		0	V
VANA _{I/O}	Analog I/O D- , D+, NTC, ICHG, VOUTB	-0.3	VINT + 0.3	V
VDIG _{I/O}	Digital I/O VOUTBSET0, VOUTBSET1, VTERMSET, SHPHLD, SHPACT, ISET, ERR, CHG, MODE	-0.3	VINT + 0.3	V

Table 4: Pin voltage

	Note	Min.	Max.	Unit
Storage temperature		-40	+125	°C
MSL	Moisture Sensitivity Level		2	
ESD HBM	Human Body Model Class 2		2	kV
ESD CDM	Charged Device Model		500	V

Table 5: Environmental (WLCSP package)



5 Recommended operating conditions

The operating conditions are the physical parameters that the chip can operate within.

Symbol	Parameter	Notes	Min.	Nom.	Max.	Unit
V _{BUS_{OP}}	Supply voltage		4.1	5	6.7	V
V _{BAT_{OP}}	Battery voltage		2.30		4.35	V
T _J	Junction temperature		-40		+125	°C
T _O	Operating temperature	Ambient	-40		+85	°C

Table 6: Recommended operating conditions

5.1 Dissipation ratings

Thermal resistances and thermal characterization parameters as defined by JESD51-7 are shown in the following table.

Symbol	Parameter	WLCSP 25 pins	Units
R _{θJA}	Junction-to-ambient thermal resistance	50.7	°C/W
R _{θJC(top)}	Junction-to-case (top) thermal resistance	9.2	°C/W
R _{θJB}	Junction-to-board thermal resistance	22.6	°C/W
Ψ _{JT}	Junction-to-top characterization parameter	1.05	°C/W
Ψ _{JB}	Junction-to-board characterization parameter	23	°C/W

Table 7: Recommended operating conditions

5.2 WLCSP light sensitivity

WLCSP package is sensitive to visible and near infrared light, which means that a final product design must shield the chip properly.

6 Core components

6.1 SYSREG — System regulator

The input voltage to the system voltage regulator (SYSREG) is supplied by **VBUS**. **VBUS** voltage is supplied by AC wall adapters or USB ports.

SYSREG is a linear voltage regulator (LDO) that supplies VINT when the device is in normal state.

Features of SYSREG are the following:

- 5 V linear voltage regulator (LDO) supplying VINT when **VBUS** is connected
- Operating voltage up to 6.7 V
- Overvoltage protection to 20 V
- USB port detection and control pin for setting the current limit on **VBUS**

Note: The **VSYS** and **DEC** pins must not be externally supplied.

6.1.1 USB port detection and VBUS current limiting

The device supports automatic detection of USB port type in line with the *Battery Charging Specification* v1.2 found on usb.org.

Primary detection is performed for Standard Downstream Port (SDP), Dedicated Charging Port (DCP), and Charging Downstream Port (CDP) USB ports. The detection sequence starts once **VBUS** is connected and completes after T_{CONNO} .

If SDP is detected, the **VBUS** current limit is set to 100 mA. An external microcontroller with a USB interface can negotiate a 500 mA limit with the USB host. It then raises the **VBUS** current limit using a GPIO to control **ISET**. This is referred to as USB port negotiation.

If DCP/CDP is detected, the **VBUS** current limit is set to 500 mA. In this case, **ISET** configuration is ignored.

It is possible to configure the device to set the **VBUS** current limit to either 100 mA or 500 mA using **ISET** and disabling USB port detection.

The following table describes **ISET**, **D+**, and **D-** configurations to fix **VBUS** current limit or set **VBUS** current limit based on either USB port detection or USB port negotiation.

Limit set method	Pin configuration	VBUS current limit
Fixed 100 mA	ISET = D- = AVSS D+ = NC	100 mA
Fixed 500 mA	ISET = VSYS D- = AVSS D+ = NC	500 mA
USB port detection	ISET = AVSS D+ and D- are connected to host	100 mA if SDP detected 500 mA if DCP/CDP detected
USB port detection and negotiation (requires a USB enabled microcontroller)	ISET = microcontroller GPIO D+ and D- connected to USB host	100 mA if SDP detected, ISET = LOW 500 mA if SDP detected, ISET = HIGH 500 mA if DCP/CDP

Table 8: Pin configuration for VBUS current limit

When a microcontroller is controlling **ISET** with GPIO for USB port negotiation, **ISET** must be set LOW on reset and whenever USB is disconnected. **ISET** is only set HIGH when the USB port is SDP and negotiation for a higher current limit is complete.

See the circuit schematics in the [Reference circuitry](#) on page 44 for designs illustrating these configurations.

6.1.2 SYSREG resistance and output voltage

SYSREG regulates the VINT voltage to $VSYS_{REG}$. When the VBUS pin voltage is below $VSYS_{REG}$, there is typically RON_{REG} resistance between VBUS and VINT.

6.1.3 VBUS overvoltage and undervoltage protection

The overvoltage threshold for VBUS is $VBUS_{OVP}$. The undervoltage threshold for VBUS is $VBUS_{MIN}$.

SYSREG is disabled when VBUS voltage is above the overvoltage threshold $VBUS_{OVP}$, or below the undervoltage threshold $VBUS_{MIN}$. This isolates VBUS and prevents current flowing from VINT to VBUS.

6.1.4 VBUS disconnect

SYSREG isolates VBUS from VINT when VBUS is disconnected and the voltage drops below $VBUS_{MIN}$.

When VBUS reaches $VBUS_{ULP}$, the device enters an ultra-low power (ULP) operation mode. This takes $T_{DISCONN}$, dependent on capacitive load on VBUS. The device stays in a ULP mode while VBUS is under $VBUS_{ULP}$.

6.1.5 Electrical parameters

Symbol	Description	Min.	Typ.	Max.	Units
$IBUS_{LIM1}$	Max VBUS input current, CDP/DCP USB or ISET = HIGH	450	-	500	mA

Symbol	Description	Min.	Typ.	Max.	Units
IBUS _{LIM0}	Max VBUS input current, SDP USB and ISET = LOW, 25°C	90	-	100	mA
VINT _{REG}	Regulated VINT voltage from SYSREG, VBUS = 6 V		5.2		V
RON _{REG}	SYSREG on resistance, ISET = HIGH	-	440	720	mΩ
VBUS _{OVP}	Overvoltage protection threshold		6.9		V
VBUS _{MIN}	Undervoltage threshold		3.9		V
VBUS _{ULP}	Threshold for entering ULP mode		1.8		V
VBUS _{POR}	Power-on reset release voltage for VBUS		3.9		V
VBUS _{BOR}	Brownout reset trigger voltage for VBUS ¹		3.8		V
T _{CONN0}	Time for USB detection, ISET = LOW		-	700	ms
T _{CONN1}	Time for VINT to settle after VBUS connection, ISET = HIGH, no load	-	1.2		ms
T _{DISCONN}	Time for system to reach ULP mode after VBUS disconnect, C _{VBUS} = 10 μF	-	110		ms

Table 9: Electrical parameters

¹Device enters BOR only if (V(**VBUS**) < VBUS_{BOR}) AND (V(**VBAT**) < VBAT_{BOR}).

6.1.6 Electrical characteristics

The following graphs show SYSREG electrical characteristics.

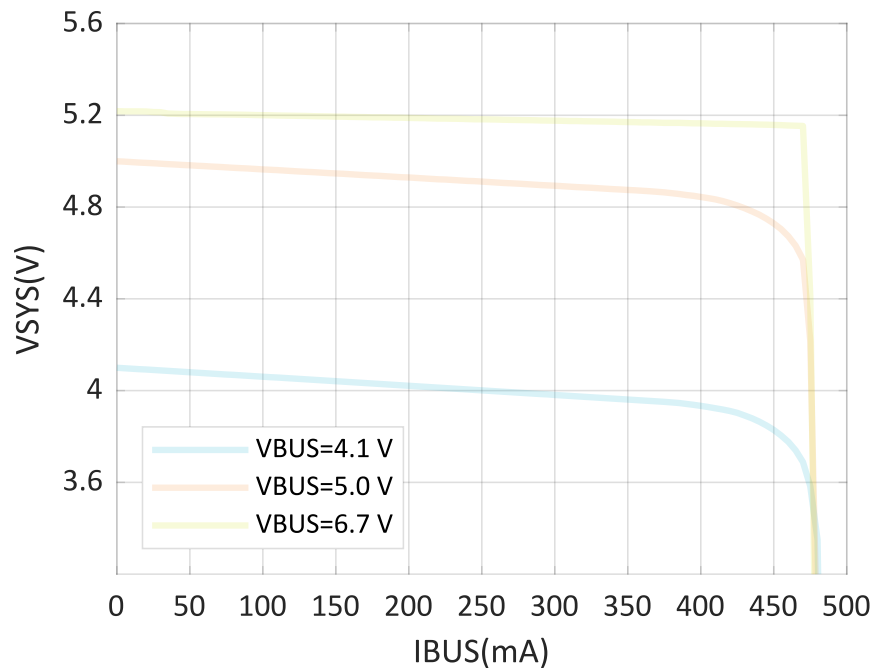

Figure 5: VSYS voltage vs. VBUS current, ILIM=500 mA

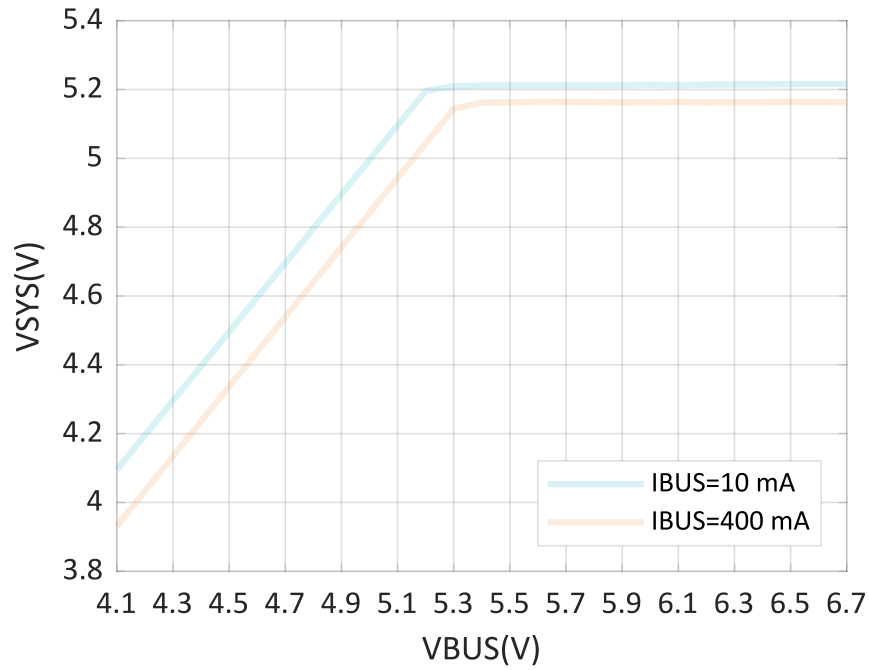

Figure 6: VSYS voltage vs. VBUS voltage, ILIM=500 mA

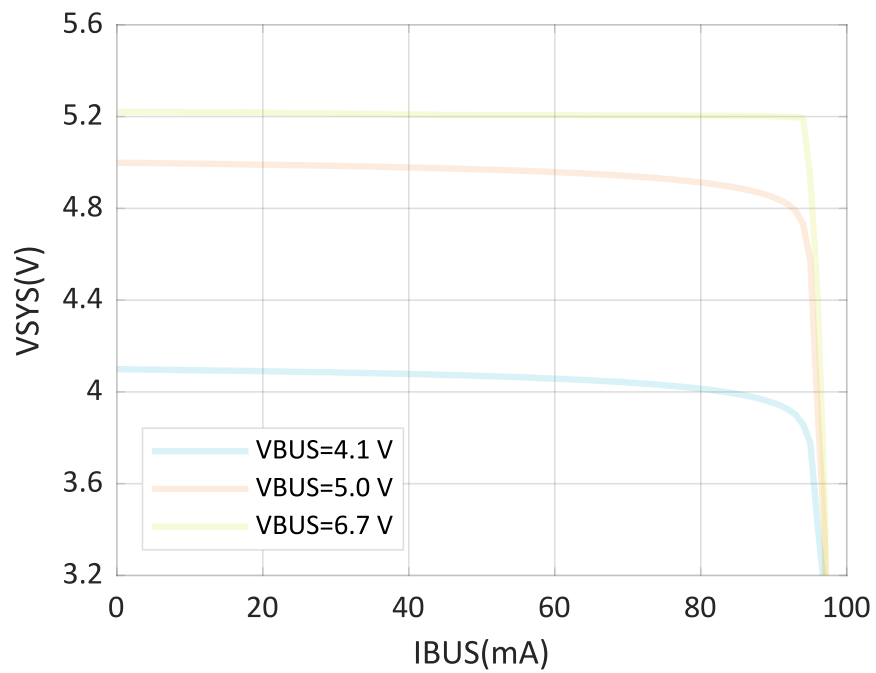

Figure 7: VSYS voltage vs. VBUS current, ILIM=100 mA

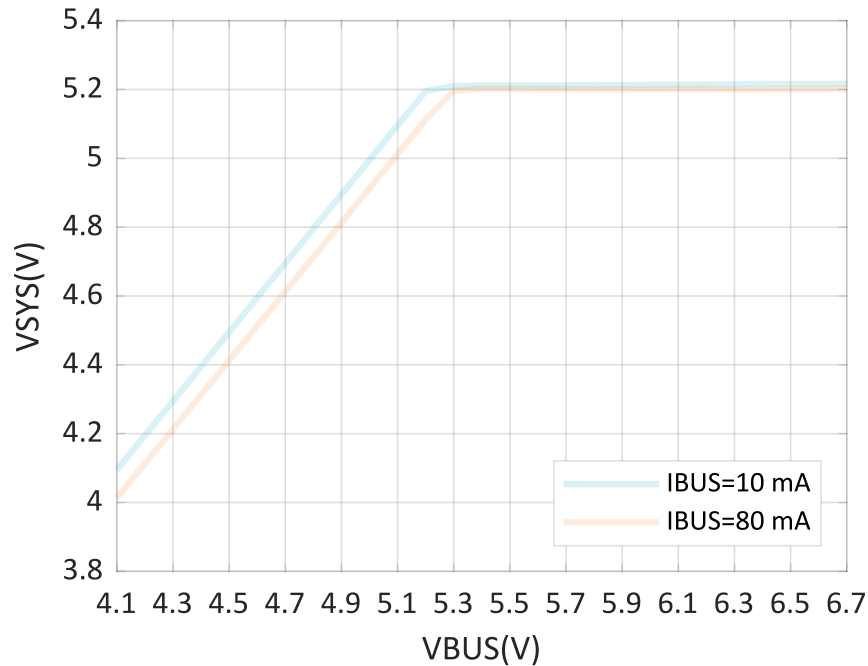

Figure 8: VSYS voltage vs. VBUS voltage, ILIM=100 mA

6.2 CHARGER — Battery charger

The battery charger is suitable for any general purpose applications with lithium-ion/lithium-polymer battery types.

The main features of the battery charger are the following:

- Linear charger for Li-ion/Li-poly battery chemistries
- Configurable charge current with a resistor connected to the **ICHG** pin (from 20 mA to 400 mA)
- Bidirectional power FET for dynamic power-path management
- Active current limitation when **VBAT** supplies **VINT**
- Selectable termination voltage of 4.1 V or 4.2 V through the **VTERMSET** pin
- Automatic trickle, constant current, constant voltage, and end-of-charge/recharge cycle
- JEITA compliant battery thermal protection (NTC) with standard and extended temperature range

6.2.1 Charging cycle

Battery charging starts after a **VBUS** connection and battery detection, see [Battery detection and UVLO](#) on page 20.

If a battery is found, trickle charging begins. Fast charging starts when the battery voltage is above $V_{\text{TRICKLE_FAST}}$. After the battery voltage reaches V_{TERM} , the charger enters constant voltage charging. The battery voltage is maintained while monitoring current flow into the battery. When the current into the battery drops below I_{TERM} , charging is complete. The charger waits until the battery voltage is below V_{RECHARGE} before starting a new charging cycle.

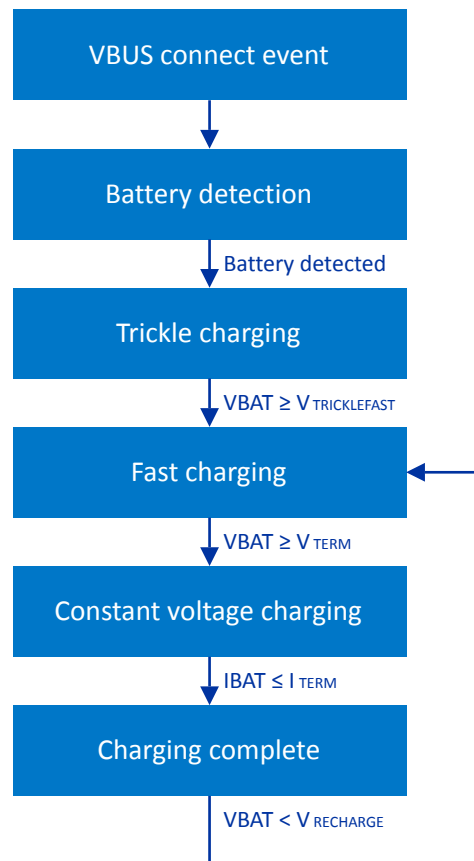

Figure 9: Charging cycle flow chart

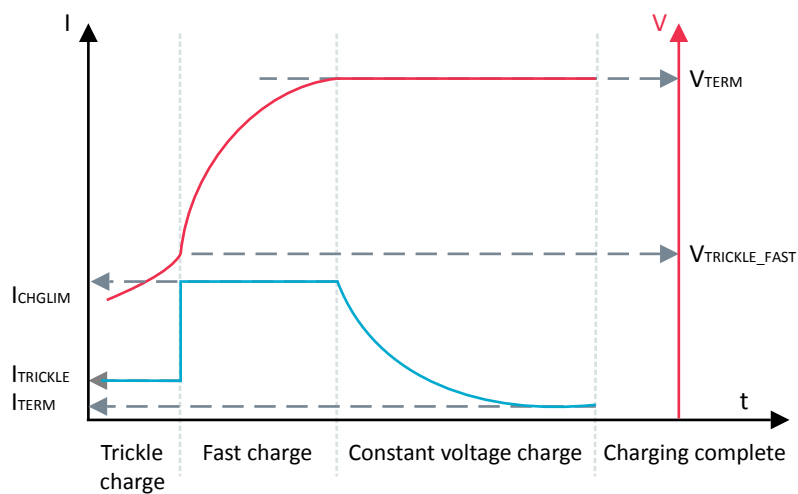

Figure 10: Charging cycle

6.2.2 Battery detection and UVLO

Battery detection and undervoltage lockout (UVLO) release is run before charging starts.

The charger waits until a battery is detected before charging. If UVLO release fails, then the charger retries every 500 ms.

Note: UVLO release refers to a UVLO circuit implemented in the battery pack. The device does not have an undervoltage lockout circuit and it must be implemented in the battery pack to protect against battery failure due to long term discharge.

6.2.3 Termination voltage (VTERMSET)

The termination voltage, V_{TERM} , is set using **VTERMSET** to support two values of battery charging termination voltage.

VTERMSET	V_{TERM} threshold
LOW	4.1 V
HIGH	4.2 V

Table 10: VTERMSET

6.2.4 Termination and trickle charge current

Termination current and trickle charge current are set to a percentage of the charge current limit (I_{CHGLIM}).

See [Electrical parameters](#) on page 24 for the limits.

6.2.5 Charge current limit (ICHG)

The charge current limit is set between 20 mA and 400 mA by connecting the R_{ICHG} resistor to the **ICHG** and **AVSS** pins.

The following equation gives the resistance to be connected based on the I_{CHGLIM} .

$$R_{\text{ICHG}} = \frac{625}{I_{\text{CHGLIM}}} - 1562.5$$

The following apply when the R_{ICHG} resistor is between 0 Ω and 30 k Ω .

- I_{CHGLIM} is the fast charge current limit in Amps
- R_{ICHG} is the resistance to be connected between the **ICHG** and **AVSS** pins in Ω

Common values are provided in the following table.

R_{ICHG} resistor value	Nominal charge current limit, I_{CHGLIM}	Error
0 (short to AVSS)	400 mA	$\pm I_{\text{CHGACC}}\%$
1.5 k Ω	200 mA	$\pm (I_{\text{CHGACC}} + R_{\text{ICHGACC}})\%$
4.7 k Ω	100 mA	$\pm (I_{\text{CHGACC}} + R_{\text{ICHGACC}})\%$
11 k Ω	50 mA	$\pm (I_{\text{CHGACC}} + R_{\text{ICHGACC}})\%$
30 k Ω	20 mA	$\pm (I_{\text{CHGACC}} + R_{\text{ICHGACC}})\%$

Table 11: Common charge current values

Note: I_{CHGLIM} must be set at or below the safe charge current limit of the battery according to the battery specification.

6.2.6 Battery thermal protection using NTC thermistor (NTC)

Battery thermal protection is implemented in the following two ways.

- Using a battery pack with an integrated NTC thermistor
- Connecting a thermistor between the **NTC** pin and the **AVSS** pin

The thermistor needs to have thermal contact with the battery and preferably within the battery pack. Recommended values for the NTC thermistor are found in the following table.

Parameter	Value	Unit
Nominal resistance at 25°C	10	kΩ
Resistance accuracy	1	%
B25/50 constant	3380	Kelvin
B25/85 constant	3434 to 3435	Kelvin
B constant accuracy	1	%

Table 12: Recommended NTC thermistor values

If the thermal protection feature is not used, then a 10 kΩ, ≤20% accuracy resistor should be connected between **NTC** and **AVSS** pins.

To provide JEITA compliant thermal protection, the charge current limit and termination voltage are adjusted according to the NTC thermistor measurement.

Temperature region	Battery temperature	Charging current	Termination voltage
Cold	$T < 0^{\circ}\text{C}$	0 (OFF)	NA
Cool	$0^{\circ}\text{C} < T < 10^{\circ}\text{C}$	I_{REDUCED}	V_{TERM}
Nominal	$10^{\circ}\text{C} < T < 45^{\circ}\text{C}$	I_{CHGLIM}	V_{TERM}
Warm	$45^{\circ}\text{C} < T < 60^{\circ}\text{C}$	I_{CHGLIM}	$V_{\text{TERM}} - V_{\text{THIGH_DELTA}}$
Hot	$T > 60^{\circ}\text{C}$	0 (OFF)	NA

Table 13: Battery temperature ranges

6.2.7 Charger thermal regulation

If the device junction temperature exceeds T_{HIGH} and CHARGER is in Fast Charge mode, the charge current is reduced to I_{REDUCED} .

6.2.8 Charger error conditions

A CHARGER error condition occurs when one of the following are present:

- A battery short (**V_{BAT}** to **AVSS**)
- Battery voltage lower than $V_{\text{BAT_CHARGE_MIN}}$ after battery detection due to a fault with the battery
- Trickle charge timeout; see $T_{\text{OUT_TRICKLE}}$
- Constant voltage charge/fast charge timeout; see $T_{\text{OUT_CHARGE}}$
- Device internal error occurs when CHARGER is self-checking

After an error is detected, CHARGER is disabled, the charging error indication is activated, and the charging indication is deactivated. Error conditions are cleared when **V_{BUS}** is disconnected and reconnected again.

Note: The constant voltage/fast charge timeout is the combined time spent in both constant voltage charge and fast charge, $T_{\text{OUT_CHARGE}}$.

6.2.9 Charging indication (CHG) and charging error indication (ERR)

The charging indication pin **CHG** and charging error indication pin **ERR** sink 5 mA of current when active. They are high impedance when disabled. This is suitable for driving LEDs or connecting to host GPIOs in a weak pull-up configuration.

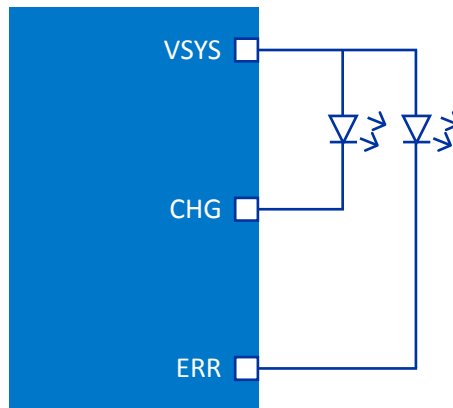

Figure 11: Configuration for connecting to LEDs

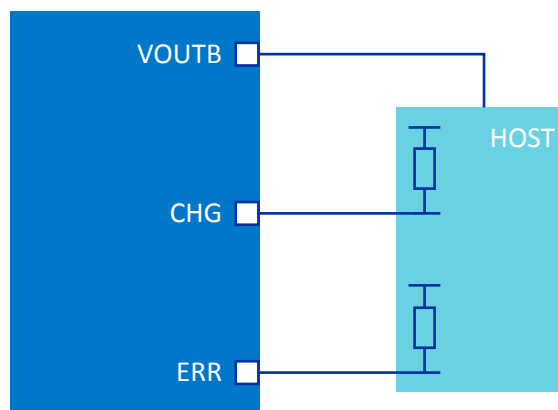

Figure 12: Configuration for connecting to a host

Note: To configure both LED indication and connection to a host, the GPIO input voltage range tolerance must be met, or an external circuit may be required. See [Reference circuitry](#) on page 44.

The charging indication pin, **CHG**, is active while the battery is charging.

The charging error indication pin, **ERR**, is activated when an error occurs, see [Charger error conditions](#) on page 22.

6.2.10 DPPM — Dynamic power-path management

CHARGER manages battery current flow to maintain VINT voltage.

The system load requirements are prioritized over battery charge current when **VBUS** is connected and the battery is charging. The battery is isolated when **VBUS** is connected and the battery is fully charged. SYSREG supplies the load unless the load exceeds SYSREG limits. When **VBUS** is disconnected, CHARGER switches to battery supply.

During charging, if the combined current load (I_{LOAD}) on VINT (including BUCK input current) and **VBAT** (I_{CHG}) exceeds the current provided by SYSREG (I_{LIM}), the battery charge current decreases to maintain the VINT voltage. The battery charger reduces the current to maintain the internal voltage: $VINT = V(VBAT) +$

$V_{\text{DROPOUT_CHARGER}}$. If more current is required, CHARGER enters Supplement mode, switching to provide current from the battery, up to $I_{\text{BAT_LIM}}$.

If a charge cycle ends and I_{LOAD} exceeds I_{LIM} , CHARGER connects the battery and enters Supplement mode to maintain VINT.

When **VBUS** and the battery are connected, the maximum supported load is $I_{\text{LIM}} + I_{\text{BAT_LIM}}$.

When **VBUS** is disconnected, CHARGER sources current for VINT from the battery. In Supplement mode, or when **VBUS** is disconnected, VINT voltage is the same as the battery voltage.

VBUS connected	Battery connected	Load	CHARGER	VINT supply	VINT voltage
Yes	Yes	$(I_{\text{LOAD}} + I_{\text{CHGLIM}}) < I_{\text{LIM}}$	Charging	VBUS	$V(\text{VBUS})$
Yes	Yes	$(I_{\text{LOAD}} + I_{\text{CHGLIM}}) > I_{\text{LIM}}$ $I_{\text{LOAD}} < I_{\text{LIM}}$	Charging (I_{CHG} reduced)	VBUS	$V(\text{VBAT}) + V_{\text{DROPOUT_CHARGER}}$
Yes	Yes	$I_{\text{LOAD}} > I_{\text{LIM}}$	Supplement mode	VBUS and VBAT	$V(\text{VBAT})^1$
Yes	No	$I_{\text{LOAD}} < I_{\text{LIM}}$	N/A	VBUS	$V(\text{VBUS})$
No	Yes	$I_{\text{LOAD}} \leq I_{\text{BAT_LIM}}$	N/A	VBAT	$V(\text{VBAT})^1$

Table 14: Battery supply

¹CHARGER has a resistance of $R_{\text{ON_CHARGER}}$ between **VBAT** and VINT. The voltage drop from **VBAT** to VINT is $I_{\text{BAT}} \times R_{\text{ON_CHARGER}}$, where I_{BAT} is the current being drawn from the battery.

6.2.11 Electrical parameters

Symbol	Description	Min.	Typ.	Max.	Unit
I_{CHGACC}	Fast Charge current accuracy, 0.1% accuracy external resistor		± 10		%
V_{TERM0}	Termination voltage, VTERMSET = LOW	-	4.1	-	V
V_{TERM1}	Termination voltage, VTERMSET = HIGH	-	4.2	-	V
V_{TERMACCO}	Termination voltage accuracy, $T_{\text{ambient}} = 25^\circ\text{C}$	-0.5	-	0.5	%
	Termination voltage accuracy	-1	-	+1	%
$V_{\text{THIGH_DELTA}}$	VTERM voltage reduction at high temperature		100		mV
I_{TERM}	Termination current	8	10	12	% of ICHG
I_{TRICKLE}	Trickle charge current		10		% of ICHG
I_{REDUCED}	Fast charge current when device junction temperature is above T_{HIGH} or battery temperature is below T_{NTCCOOL}	-	50	-	% of ICHG

Symbol	Description	Min.	Typ.	Max.	Unit
THIGH	High temperature threshold	-	100	-	°C
THIGH _{HYST}	High temperature hysteresis	-	10	-	°C
V _{TRICKLE_FAST}	Trickle to Fast Charge threshold	-	2.9	-	V
V _{RECHARGE}	Recharge threshold	-	97	-	% of VTERM
VBAT _{CHARGEMIN}	Minimum voltage during charge	-	2.1	-	V
TOUT _{TRICKLE}	Trickle charging timeout	-	10	-	min
TOUT _{CHARGE}	Timeout for Fast charging and constant current charging	-	7	-	hour
V _{DROPOUT_CHARGER}	VINT - VBAT voltage for charging	-	50	-	mV
T _{REDETECT}	Period between detection events	-	500	-	ms
IBAT _{LIM}	Output current limit from battery in discharge	-	660	-	mA
RON _{CHARGER}	CHARGER resistance between VBAT and VINT in Discharge, VBAT = 3.7 V	-	130	230	mΩ
VBAT _{POR}	Power-on reset release voltage for VBAT	-	2.7	-	V
VBAT _{BOR}	Brownout reset trigger voltage for VBAT ¹	-	2.5	-	V
I _{SINK}	DC current (CHG and ERR)	-	5	-	mA
TNTC _{COLD}	JEITA cold temperature threshold (Thermistor: 10 kΩ, B25/50=3380 K)	-	0	-	°C
RNTC _{COLD_FALLING}	Resistance threshold from cool to cold	25.53	27.28	29.13	kΩ
RNTC _{COLD_RISING}	Resistance threshold from cold to cool	23.10	26.00	28.20	kΩ
TNTC _{COOL}	JEITA cool temperature threshold (Thermistor: 10 kΩ, B25/50=3380 K)	-	10	-	°C
RNTC _{COOL_FALLING}	Resistance threshold from nom. to cool	16.80	18.00	19.20	kΩ
RNTC _{COOL_RISING}	Resistance threshold from cool to nom.	15.50	17.10	18.60	kΩ
TNTC _{WARM}	JEITA warm temperature threshold (Thermistor: 10 kΩ, B25/50=3380 K)	-	45	-	°C
RNTC _{WARM_FALLING}	Resistance threshold from warm to nom.	4.86	5.13	5.43	kΩ
RNTC _{WARM_RISING}	Resistance threshold from nom. to warm	4.68	4.92	5.17	kΩ
TNTC _{HOT}	JEITA hot temperature threshold (Thermistor: 10 kΩ, B25/50=3380 K)	-	60	-	°C
RNTC _{HOT_FALLING}	Resistance threshold from hot to warm	3.04	3.19	3.35	kΩ
RNTC _{HOT_RISING}	Resistance threshold from warm to hot	2.90	3.02	3.15	kΩ

Table 15: Charger electrical parameters

¹Device enters BOR only if (V(VBUS) < VBUS_{BOR}) AND (V(VBAT) < VBAT_{BOR}).

6.2.12 Electrical characteristics

The following graphs show CHARGER electrical characteristics.

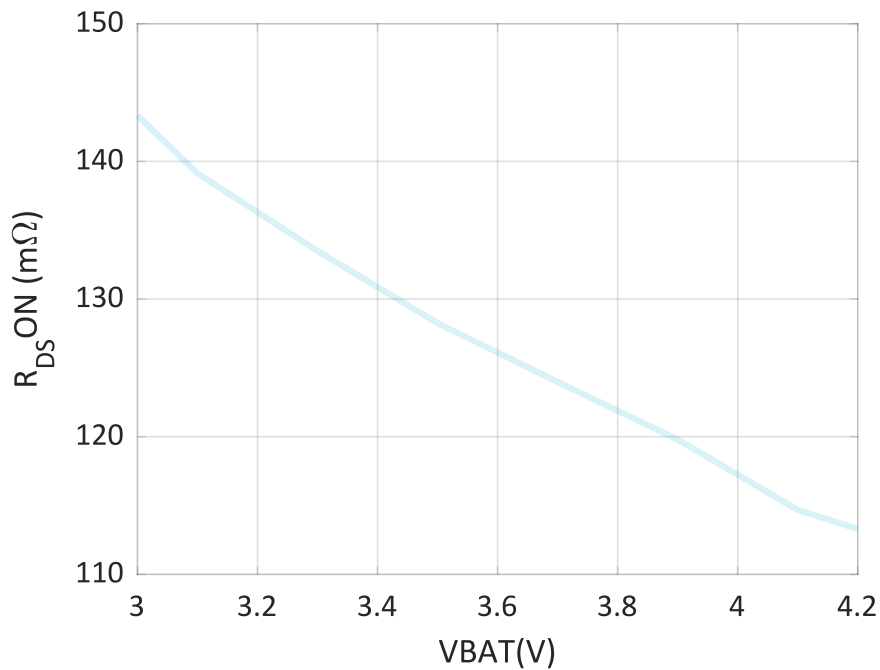

Figure 13: CHARGER RDS(ON) vs. VBAT voltage

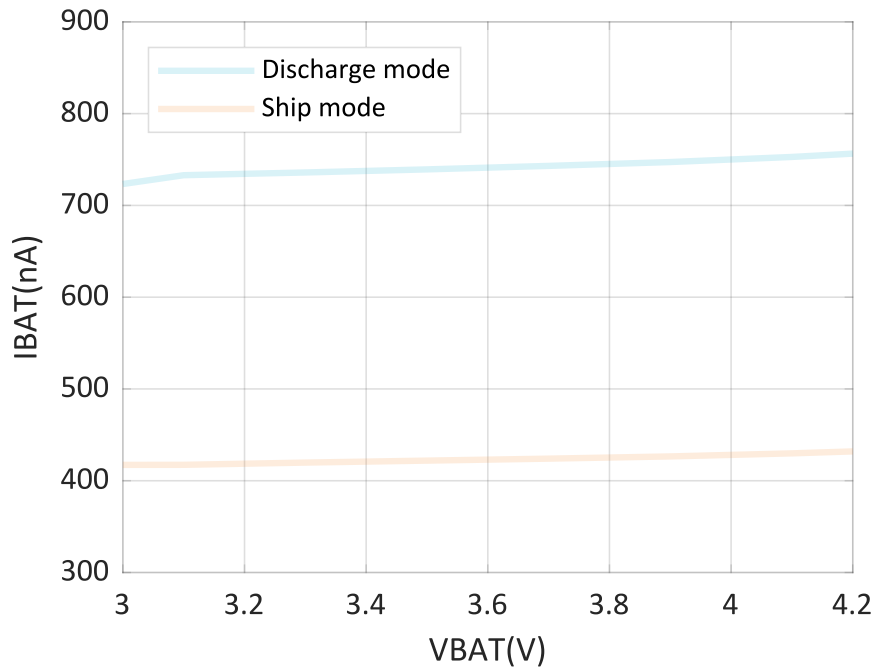

Figure 14: Quiescent VBAT current vs. VBAT voltage

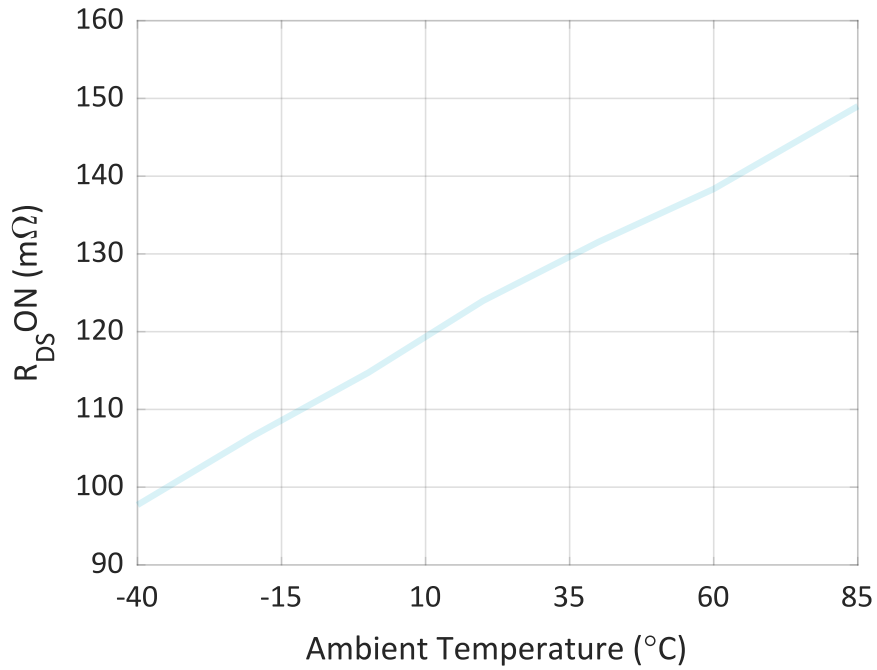

Figure 15: CHARGER $R_{DS(ON)}$ vs. temperature

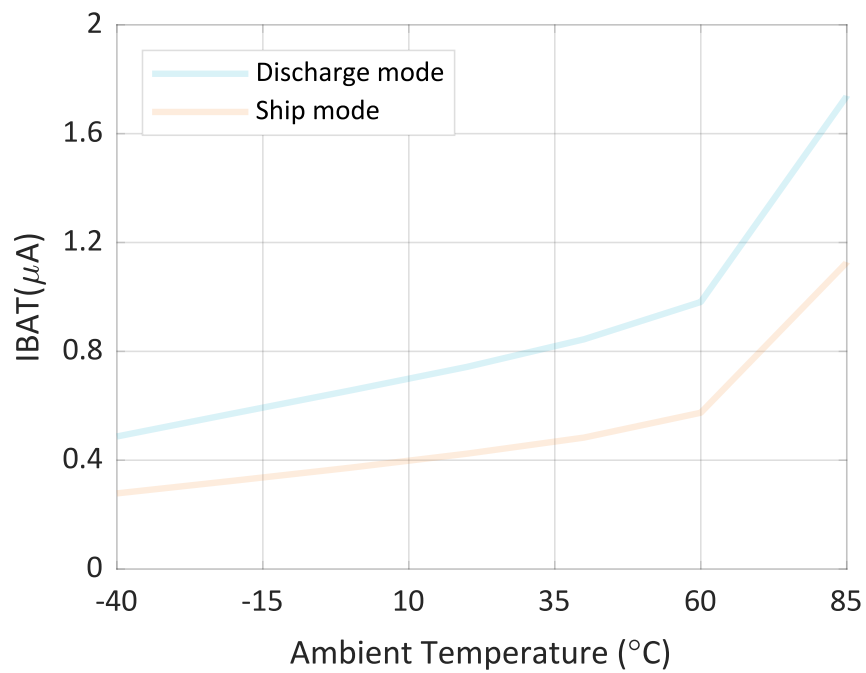

Figure 16: Quiescent VBAT current vs. temperature

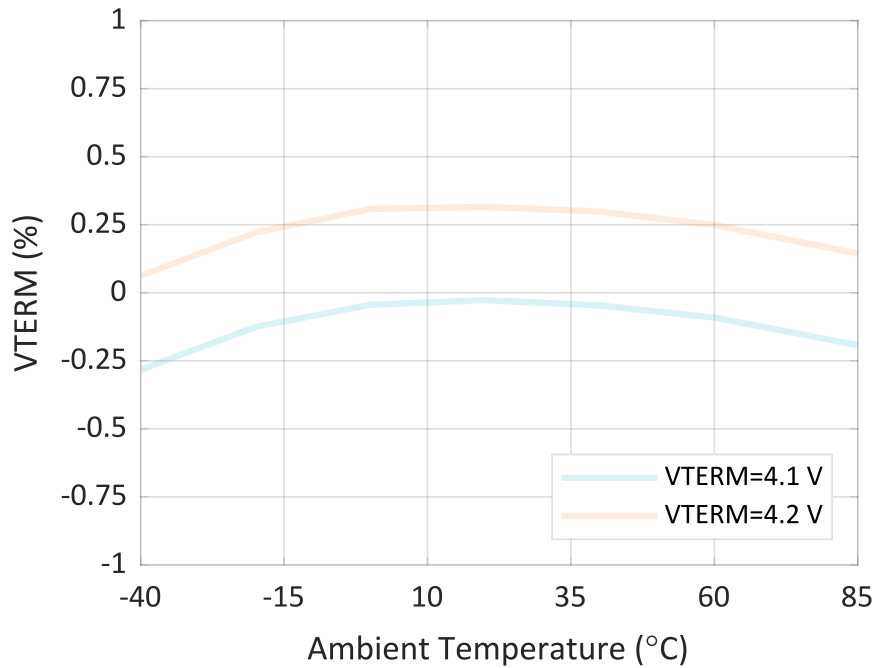

Figure 17: VTERM vs. temperature

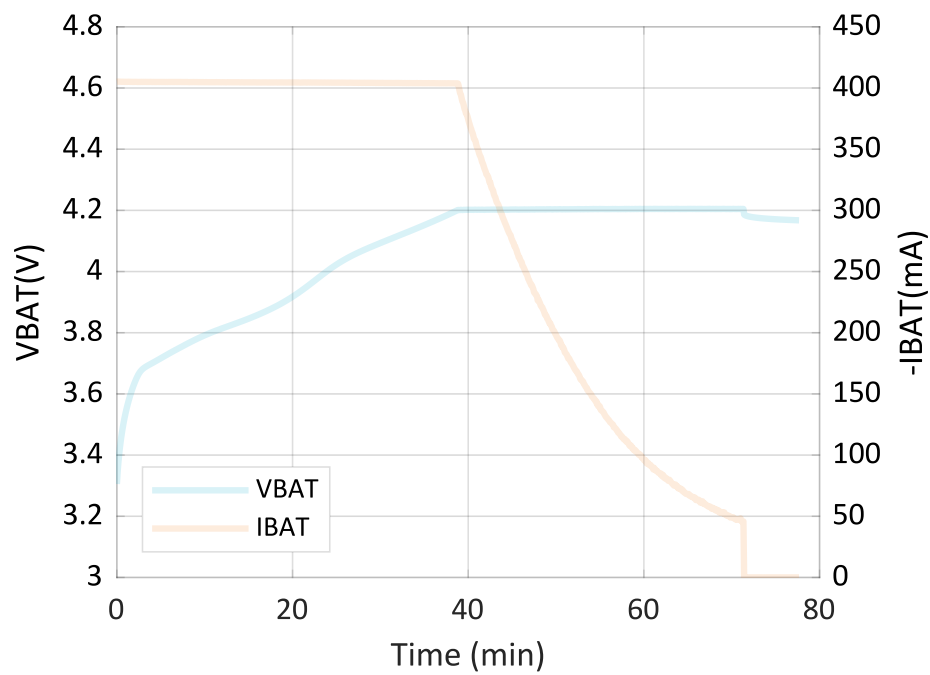

Figure 18: Charge profile with ISET=1

6.3 BUCK — Buck regulator

BUCK is a step-down DC/DC voltage regulator with the following features:

- High efficiency (low IQ) and low noise operation
- PWM and Hysteretic modes with automatic switching based on load
- **MODE** control pin for forcing PWM mode to minimize output voltage ripple
- Configurable output voltage between 1.8 V and 3 V

When VINT is above $VSYS_{BUCKMIN}$, the buck regulator is enabled and its output voltage is available at VOUTB.

BUCK features two modes of operation: hysteretic and PWM. Hysteretic mode offers efficiency for the full range of supported load currents. PWM mode provides a clean supply operation due to a constant switching frequency, F_{BUCK} . This provides optimal coexistence with RF circuits. BUCK can automatically change between Hysteretic and PWM modes. Modes are controlled by the **MODE** pin. The state of the **MODE** pin can be changed at any time.

6.3.1 Output voltage selection (VOUTBSET0, VOUTBSET1)

BUCK output voltage selection pins **VOUTBSET0** and **VOUTBSET1** should be hardwired to **DEC**, **VSYS**, or **AVSS**. Do not toggle these pins during operation.

VOUTBSET1	VOUTBSET0	VOUTB voltage
LOW	LOW	1.8 V
LOW	HIGH	2.1 V
HIGH	LOW	2.7 V
HIGH	HIGH	3.0 V

Table 16: Output voltage selection

For BUCK to supply the desired output voltage, VINT must be $V_{DROPOUT_BUCK}$ greater than the voltage on **VOUTB**.

When supplied from battery, the following equation gives the VINT:

$$VINT = V_{BAT} - I_{BAT} \times R_{ON_CHARGER}$$

Here, I_{BAT} is the current being drawn from the battery.

6.3.2 BUCK mode selection (MODE)

In Automatic mode, BUCK selects Hysteretic mode for low load currents, and PWM mode for high load currents.

This maximizes efficiency over the full range of supported load currents. In PWM mode, BUCK provides a clean supply operation due to constant switching frequency and lower voltage ripple. This allows for optimal coexistence with RF circuits. The **MODE** pin can be changed at any time.

MODE	BUCK operation mode
LOW	Automatic selection between Hysteretic and PWM modes
HIGH	PWM mode

Table 17: BUCK mode selection

6.3.3 Component selection

Recommended values for the inductor are shown in the following table.

Parameter	Value	Units
Nominal inductance	2.2	μH
Inductor tolerance	≤ 20	%
DC resistance (DCR)	≤ 400	$\text{m}\Omega$
Saturation current (I_{sat})	≥ 350	mA
Maximum current (I_{max})	≥ 350	mA

Table 18: Component selection

6.3.4 Electrical parameters

Symbol	Description	Min.	Typ.	Max.	Unit
$V_{\text{OUTB_ACC}}$	V_{OUTB} accuracy	-2	-	8	%
$I_{\text{OUTB_SHORT}}$	Short circuit current limit	-	-	400	mA
I_{PWMTHRES}	Load current threshold from Hysteretic to PWM mode (MODE = LOW)		90		mA
$I_{\text{HYSTTHRES}}$	Load current threshold from PWM to Hysteretic mode (MODE = LOW)		40		mA
$V_{\text{OUTB_RIPPLE_HYST}}$	V_{OUTB} ripple, MODE = HIGH or load current above I_{PWMTHRES}	-	-	10	mVpp
$V_{\text{OUTB_RIPPLE_HYST}}$	VOUT ripple, MODE = LOW and load current below I_{PWMTHRES}	-	-	80	mVpp
EFF_{BUCK}	Efficiency, $V_{\text{OUTBSET}} = 11$ ($V_{\text{OUTB}} = 3.0$ V), $V_{\text{INT}} = 3.7$ V, $I_{\text{OUTB}} = 100$ mA	-	93.5	-	%
$V_{\text{DROPOUT_BUCK}}$	Dropout voltage, $V(V_{\text{OUTB}}) - V_{\text{INT}}$	-	0.41		V
F_{BUCK}	Switching frequency for PWM mode	-	3.6	-	MHz
T_{PWMMODE}	Hysteretic to PWM mode transition time on MODE pin toggle	-	-	55	μs
T_{HYSTMODE}	PWM to Hysteretic mode transition time on MODE pin toggle	-	-	25	μs
T_{PWM}	Hysteretic to PWM mode transition time	-	-	90	μs
T_{HYST}	PWM to Hysteretic mode transition time	-	-	35	μs
T_{SETTLE}	Settling time to within 1% after load transient of 0 A to 100 mA	-	-	20	μs
$V_{\text{INT_BUCKMIN}}$	Minimum VINT voltage for enabling BUCK	-	2.8	-	V

Table 19: Electrical parameters

6.3.5 Electrical characteristics

The following graphs show BUCK electrical characteristics.

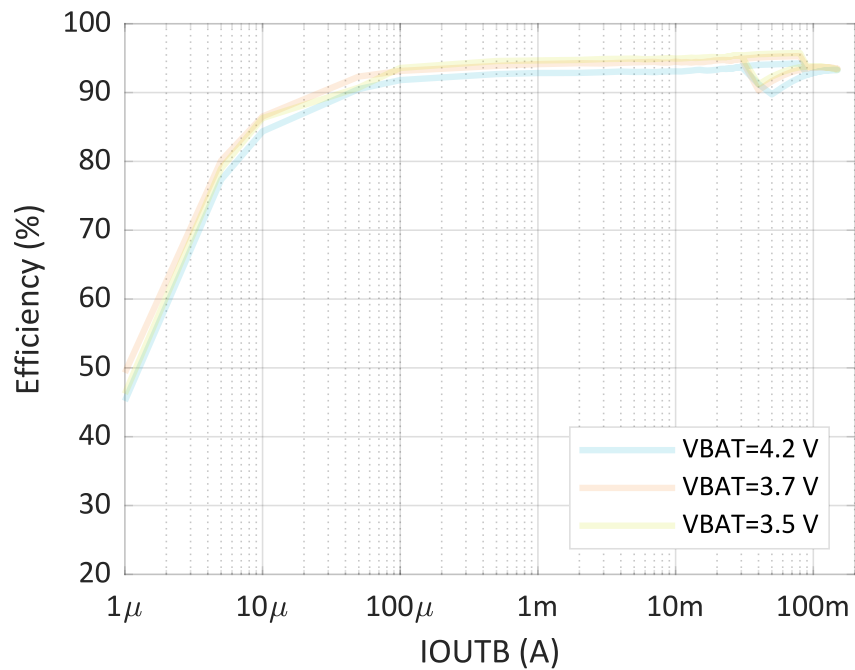

Figure 19: $V_{OUTB}=3.0$ system efficiency, $MODE=AUTO$

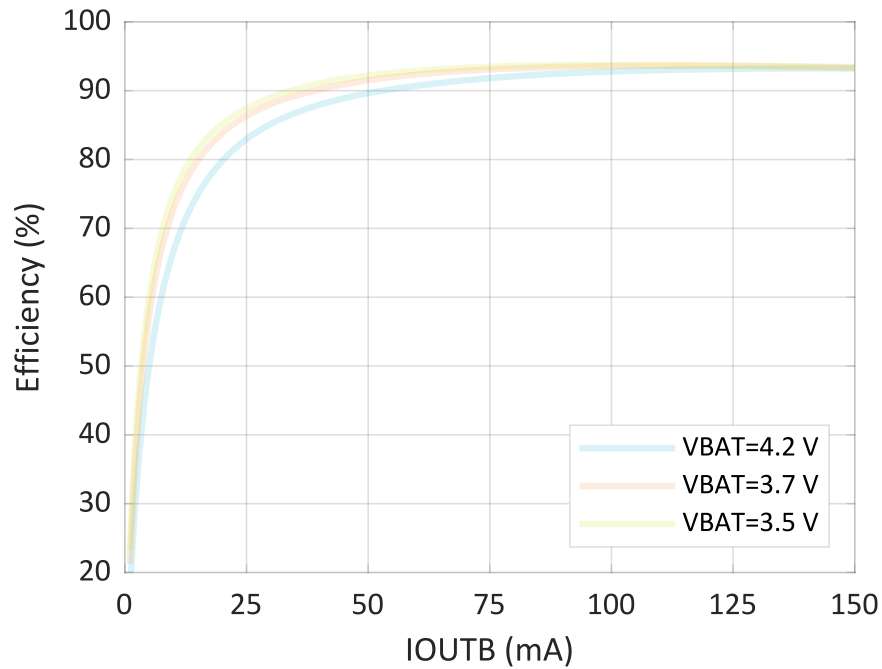

Figure 20: $V_{OUTB}=3.0$ system efficiency, $MODE=PWM$

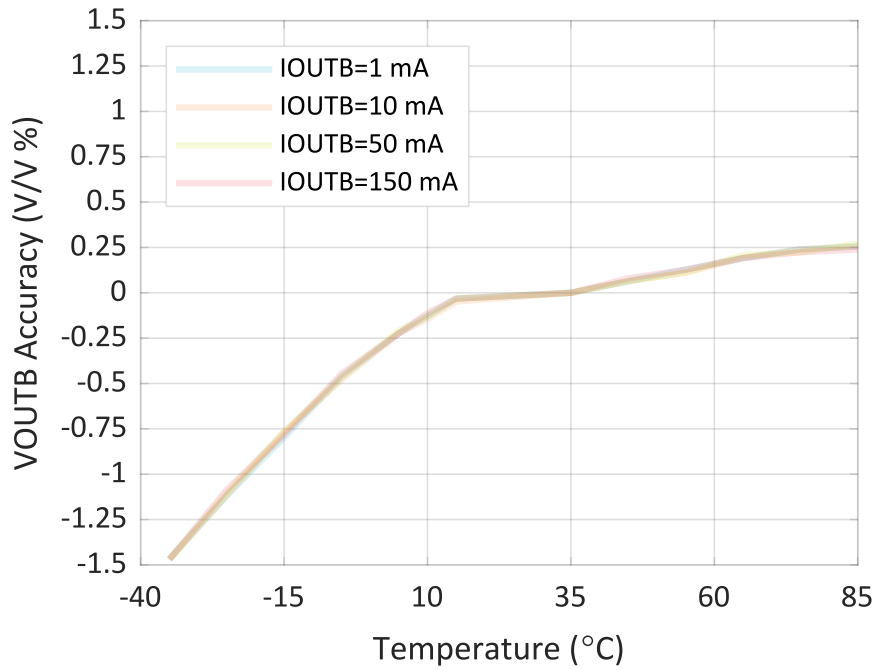

Figure 21: VOUTB=3.0: VOUTB vs. temperature (VBAT=4.2)

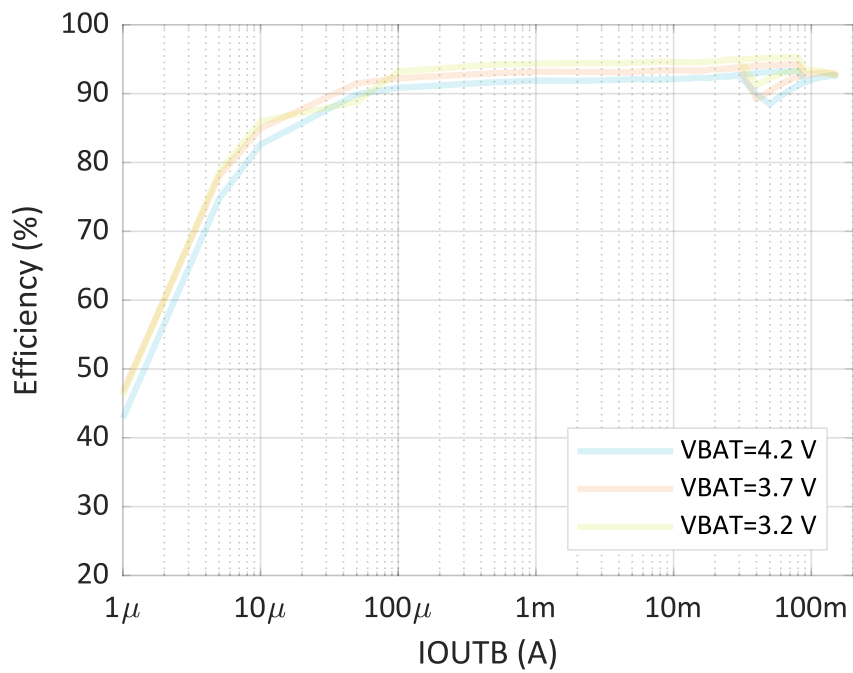

Figure 22: VOUTB=2.7 system efficiency, MODE=AUTO

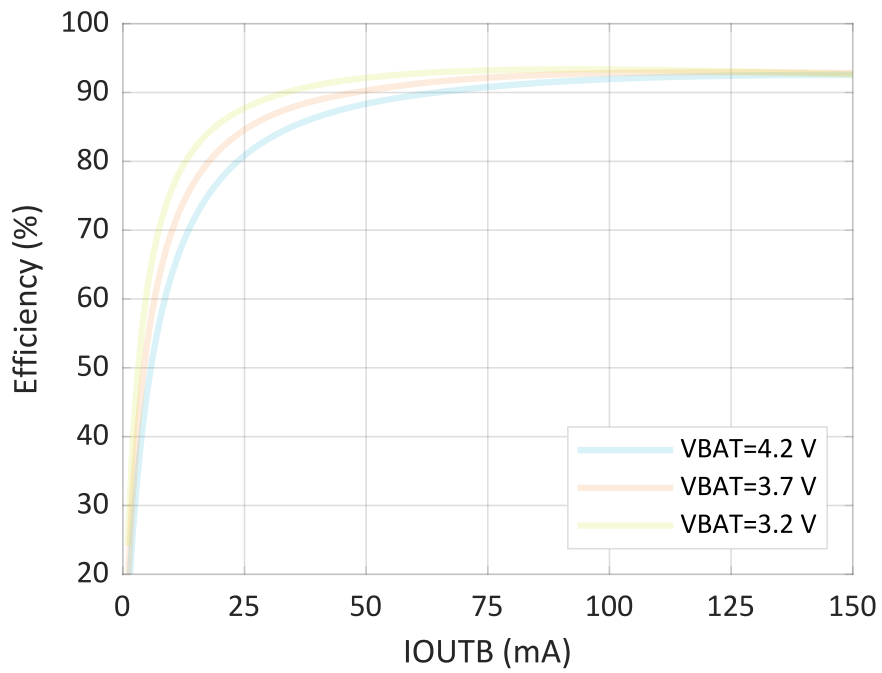

Figure 23: $V_{OUTB}=2.7$ system efficiency, $MODE=PWM$

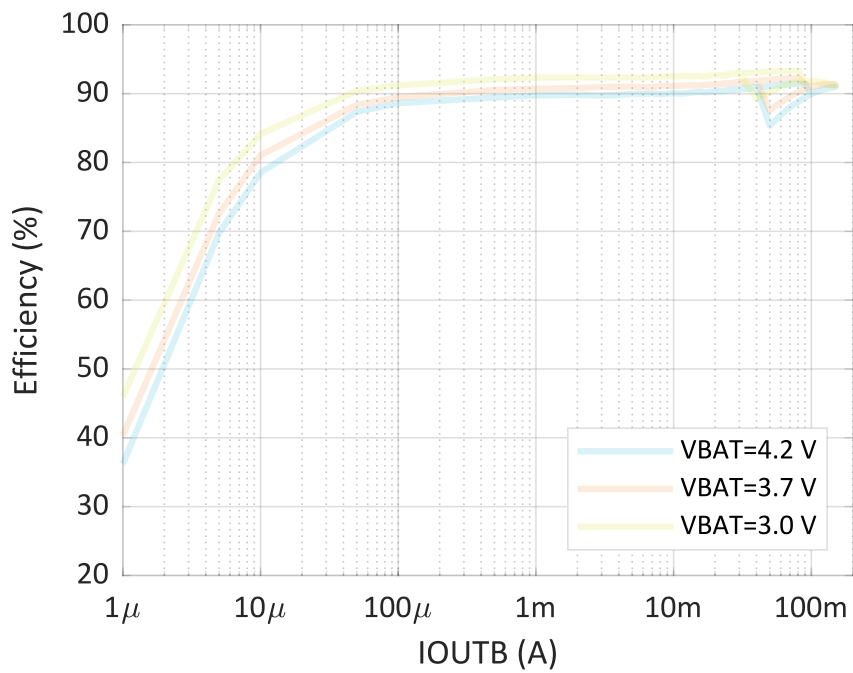

Figure 24: $V_{OUTB}=2.1$ system efficiency, $MODE=AUTO$

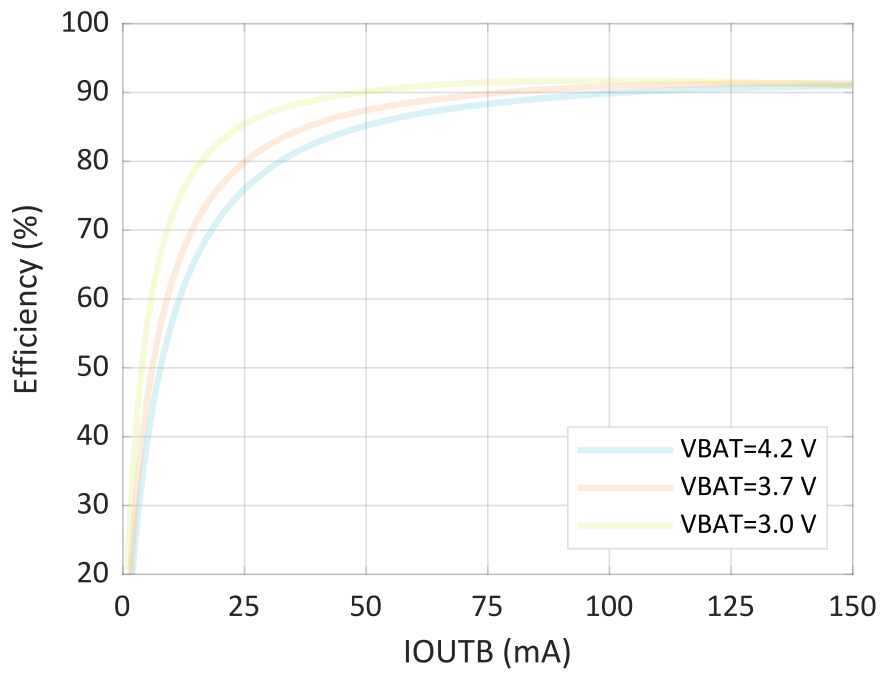

Figure 25: $V_{OUTB}=2.1$ system efficiency, $MODE=PWM$

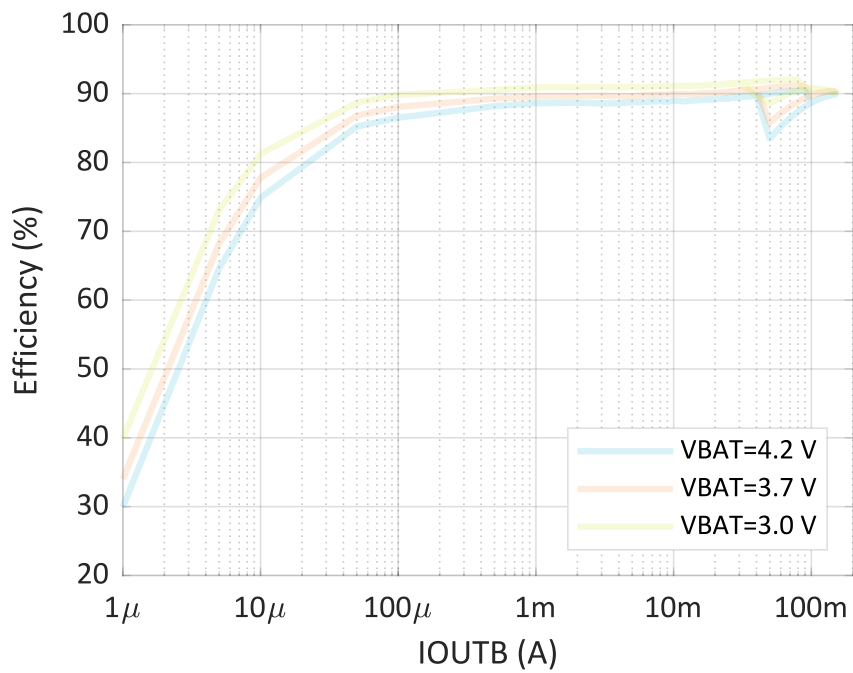

Figure 26: $V_{OUTB}=1.8$ system efficiency, $MODE=AUTO$

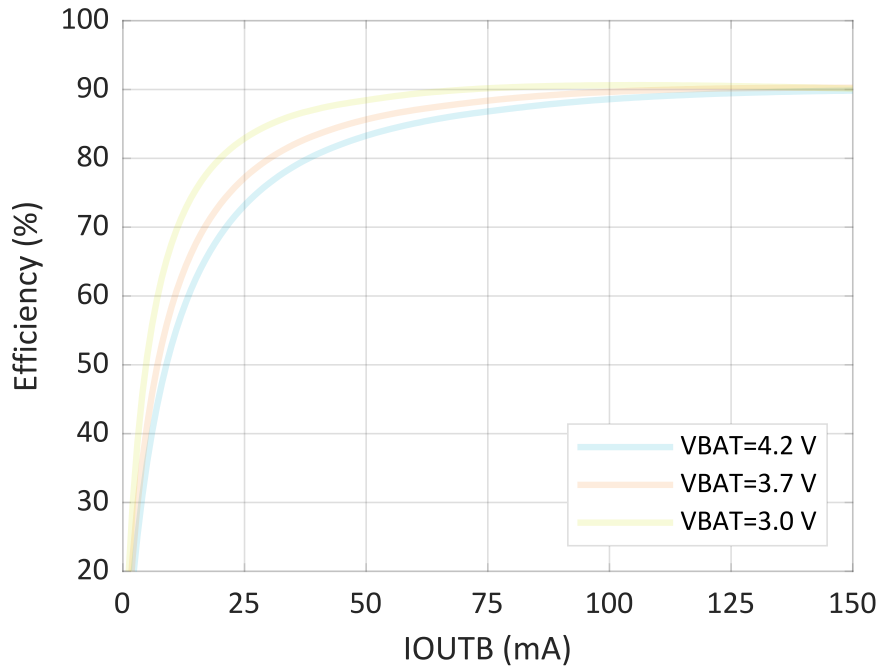

Figure 27: VOUTB=1.8 system efficiency, MODE=PWM

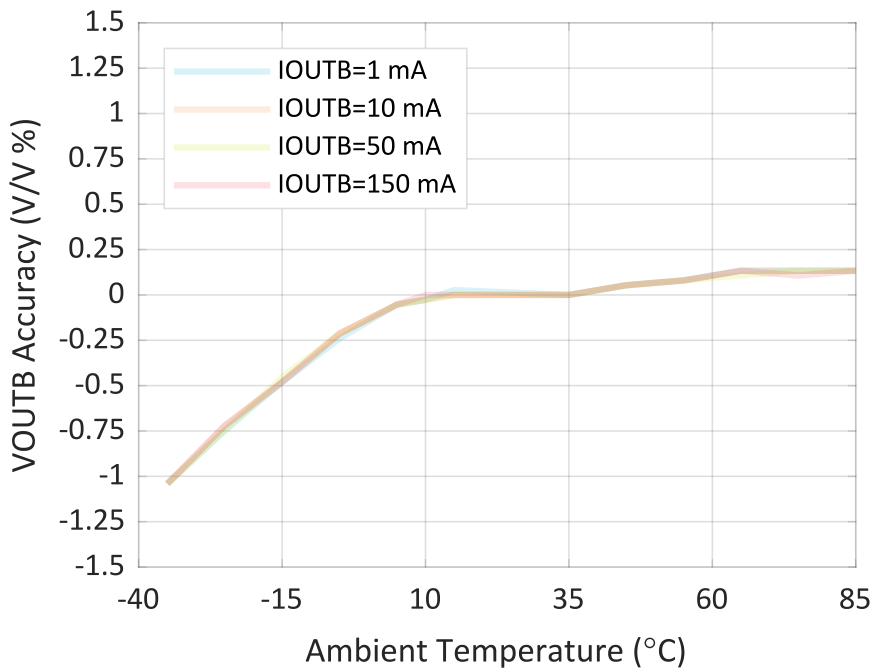

Figure 28: VOUTB=1.8 VOUTB vs. temperature (VBAT=4.2)

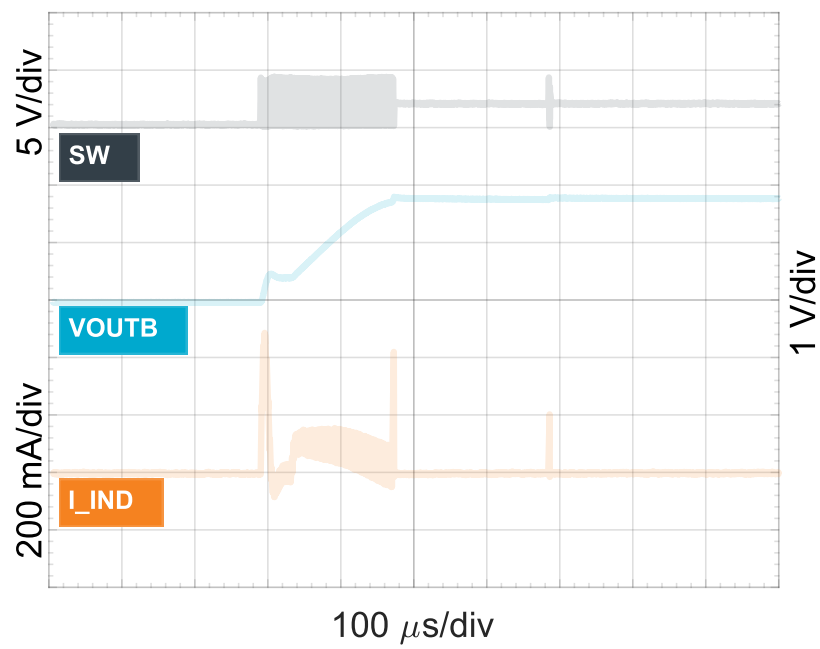

Figure 29: Startup with no load, soft start, $V_{out}=1.8$ V, $V_{BAT}=3.8$ V

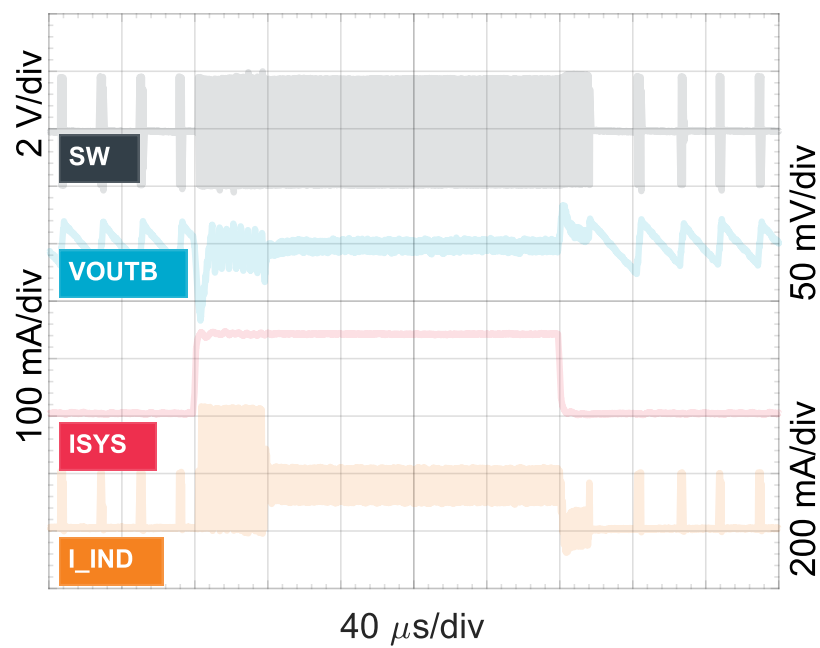

Figure 30: BUCK load transition in auto mode ($MODE=0$), $I_{out}=10$ mA \rightarrow 150 mA \rightarrow 10 mA (1 μ s step), $V_{out}=1.8$ V, $V_{BAT}=3.8$ V

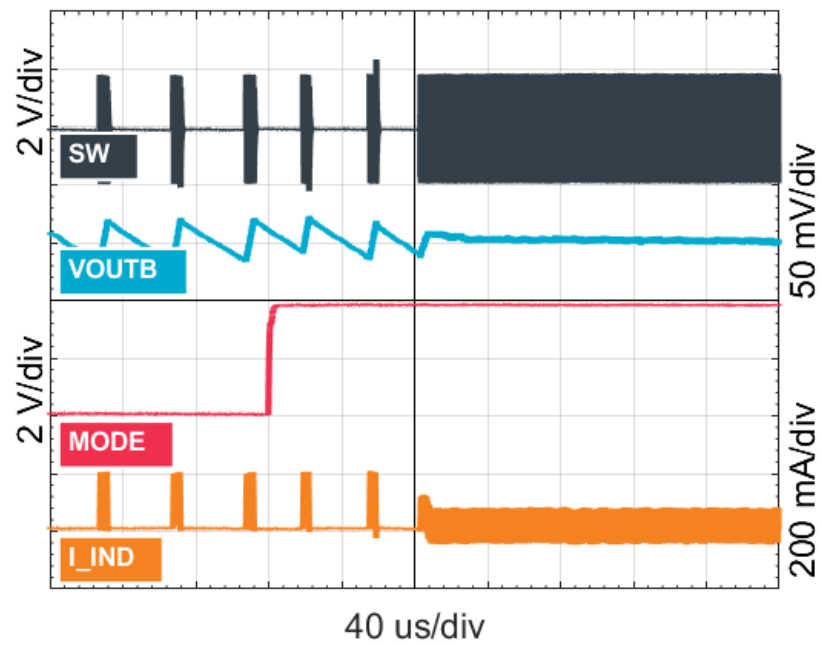

Figure 31: BUCK Mode transition, MODE pin 0 \rightarrow 1, $V_{out}=1.8\text{ V}$ $I_{out}=10\text{ mA}$

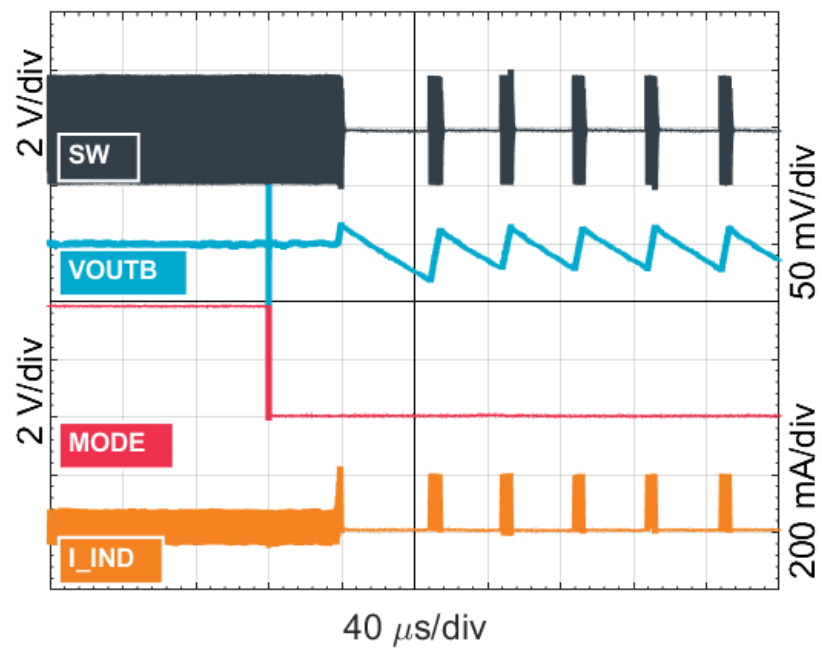

Figure 32: BUCK Mode transition, MODE pin 1 \rightarrow 0, $V_{out}=1.8\text{ V}$ $I_{out}=10\text{ mA}$

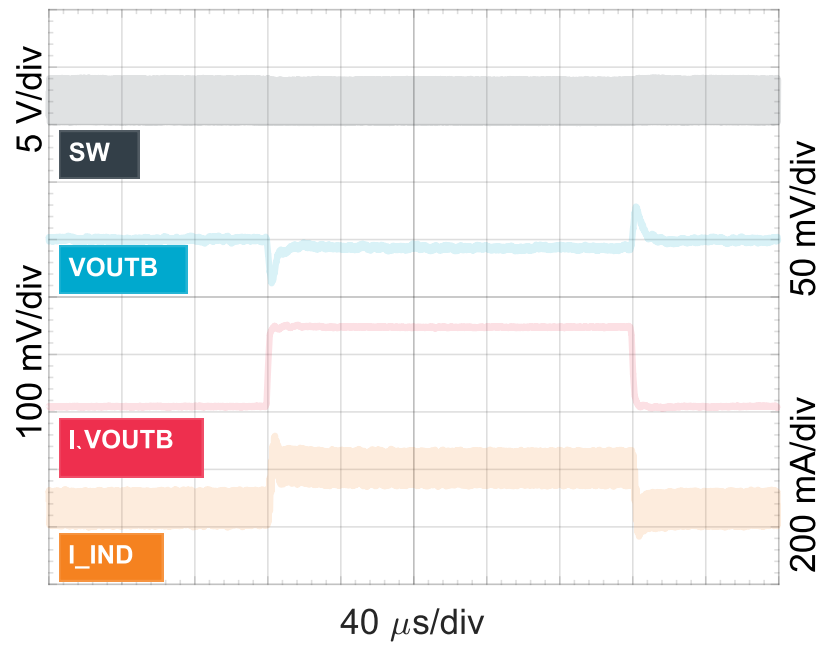

Figure 33: BUCK load transition in PWM mode (MODE=1), $I_{out}=10 \text{ mA} \rightarrow 150 \text{ mA} \rightarrow 10 \text{ mA}$ (1 μs step), $V_{out}=1.8 \text{ V}$, $V_{BAT}=3.8 \text{ V}$

7 Application

The following application example uses nPM1100 and an nRF5x wireless System on Chip (SoC). Any nRF52 or nRF53 series device with USB can be configured in the same way as this application. When using a device without USB, or for other configurations, see [Reference circuitry](#) on page 44.

The example application is for a design with the following configuration and features:

- nPM1100 BUCK regulator supplies the nRF5x device
- USB current limit negotiation
- Charging status monitoring using SoC GPIOs
- ICHG and VTERM configuration
- NTC thermistor in the battery pack
- Ship mode
- Battery monitoring circuit and low battery indication LED (this requires the device to sample the battery voltage; software is not described here)

7.1 Schematic

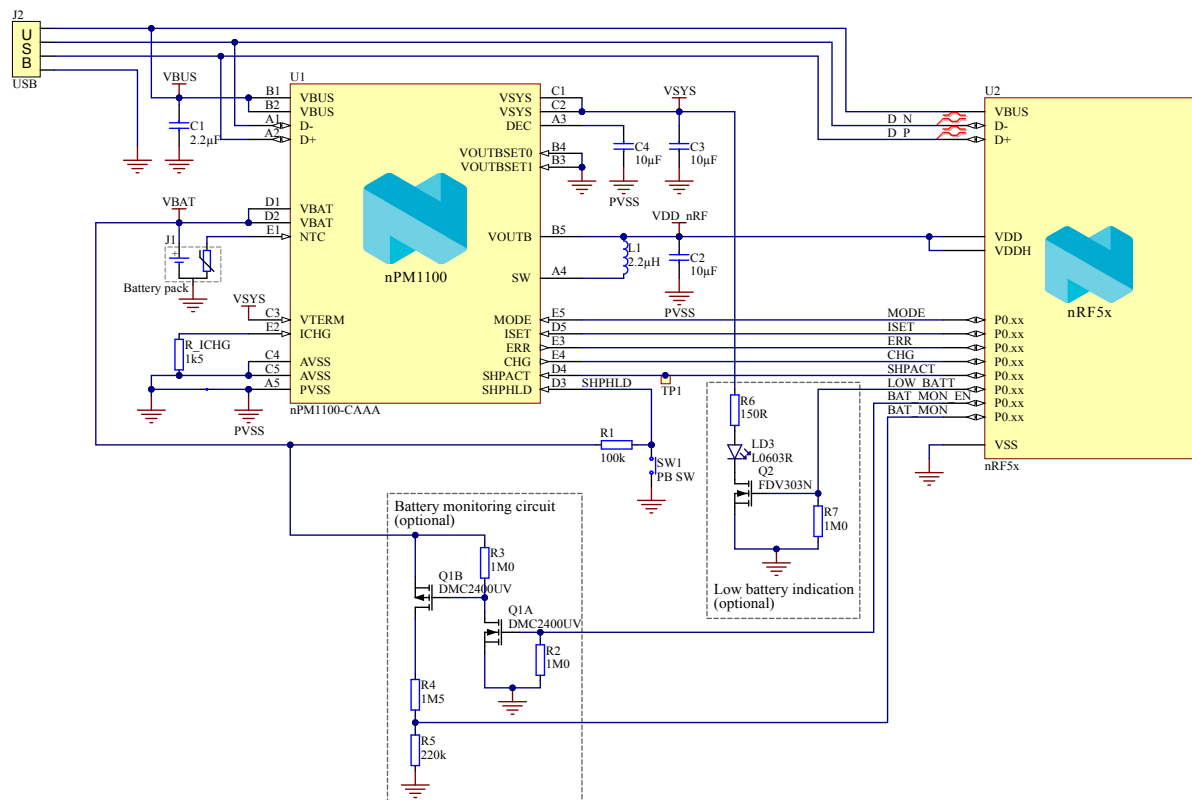

Figure 34: Application example

7.2 Supplying from BUCK

nRF5x is supplied by nPM1100 **VOUTB** at 1.8 V. BUCK mode (**MODE**) is controlled via a GPIO.

An application should not be supplied directly from **V_{BAT}** because it can disturb the battery charging process and may cause incorrect behavior from the charger. Instead, **V_{OUTB}** and/or **V_{SYS}** should be used to supply an application.

7.3 USB port negotiation

nRF5x can connect to a USB host.

Port negotiation can be performed after nPM1100 port detection. The nRF5x device and nPM1100 are both connected to USB in the application example. nPM1100 detects SDP or CDP/DCP. If SDP is detected, the USB device can negotiate with the USB host for higher current from **V_{BUS}**.

- **D+** and **D-** pins are connected to both nPM1100 and nRF5x. The nRF5x SoC must wait until nPM1100 completes port detection before enabling its USB port. See [USB port detection and V_{BUS} current limiting](#) on page 15 for port detection time after **V_{BUS}** connection.
- An nRF5x GPIO is connected to the **I_{SET}** pin and sets the **V_{BUS}** current limit after negotiation. If CDP or DCP is detected, then a 500 mA limit is automatically set regardless of **I_{SET}** state.
- **V_{BUS}** is supplied to both nPM1100 and nRF5x to supply nPM1100 SYSREG and the nRF5x V_{BUS} regulator.

See [USB port detection and V_{BUS} current limiting](#) on page 15 for a detailed description.

7.4 CHG and ERR

Pins **CHG** and **ERR** indicate charging and error states. See [Charging indication \(CHG\) and charging error indication \(ERR\)](#) on page 23 and [Charger error conditions](#) on page 22.

7.5 Termination voltage and current

The termination voltage is configured to 4.2 V via the **V_{TERMSET}** pin. See [Termination voltage \(V_{TERMSET}\)](#) on page 21.

Charge current is configured to 200 mA ($\pm 10\%$) using a 1.5 k Ω (1%) resistor to ground on the **I_{CHG}** pin. See [Charge current limit \(I_{CHG}\)](#) on page 21.

7.6 NTC configuration

The **NTC** pin is connected to an external NTC thermistor which should be placed with thermal coupling to the battery pack. See [Battery thermal protection using NTC thermistor \(NTC\)](#) on page 21 for more information.

7.7 Ship mode

Ship mode is enabled at production time via an off-board circuit with a probe point on the **SHIPACT** pin.

An external button is in the circuit to exit Ship mode. If another circuit is present instead of a button, any signal that is able to pull the **SHIPHLD** pin low for the required period can be connected to that net. See [Using Ship mode](#) on page 10 for more information.

7.8 Battery monitoring and low battery indication

The battery monitoring circuit allows the battery voltage to be sampled by the nRF5x ADC.

The transistors enable battery voltage sensing through a resistive divider. When not sampling, the transistors prevent current leakage to ground. The circuit is designed to ensure the voltage range on an analog input pin over the battery voltage is within the limits required by the nRF5x GPIO and ADC. A battery voltage of 2.8 V to 4.2 V is scaled down to 360 mV to 540 mV at **P0.xx** for sampling.

If software on nRF5x determines that the battery on nPM1100 is low, the **Low Bat LED** can be switched on via GPIO. This circuit sources the LED current from **VSYS**. **VSYS** will not be supplied after VBAT drops below $V_{BAT_{BOR}}$ because CHARGER will isolate the battery when a brownout reset occurs. See [Power-on reset \(POR\) and brownout reset \(BOR\)](#) on page 10.

8 Hardware and layout

8.1 Ball assignments

The ball assignment figure and table describe the assignments for this variant of the chip.

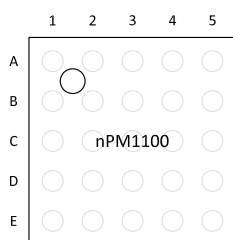

Figure 35: WLCSP ball assignments

Pin	Name	Function	Description	Recommended usage
A1	D-	Analog input	USB D- data line	
A2	D+	Analog input	USB D+ data line	
A3	DEC	Power	System decoupling capacitor	
A4	SW	Power	BUCK converter output (to inductor)	
A5	PVSS	Power	Ground (DC/DC)	
B1	VBUS	Power	Input supply	
B2	VBUS	Power	Input supply	
B3	VOUTBSET1	Digital I/O	BUCK regulator output voltage selection	Toggle only when the device is in Power OFF
B4	VOUTBSET0	Digital I/O	BUCK regulator output voltage selection	Toggle only when the device is in Power OFF
B5	VOUTB	Power	BUCK regulator output	
C1	VSYS	Power	System voltage output; automatically enabled after power-on reset	
C2	VSYS	Power	System voltage output; automatically enabled after power-on reset	

Pin	Name	Function	Description	Recommended usage
C3	VTERMSET	Digital I/O	Battery charging termination voltage selection: 0 to 4.10 V 1 to 4.20 V	Toggle only when the device is in Power OFF
C4	AVSS	Power	Ground	
C5	AVSS	Power	Ground	
D1	VBAT	Power	Battery	
D2	VBAT	Power	Battery	
D3	SHPHLD	Digital I/O	Shipping mode hold	
D4	SHPACT	Digital I/O	Shipping mode activate	
D5	ISET	Digital I/O	VBUS current limit selection: 0 mA to 100 mA (SDP mode only) 1 mA to 500 mA	
E1	NTC	Analog input	NTC resistor	
E2	ICHG	Analog input	Charge current limiting resistor	
E3	ERR	Digital OUT	Open-drain LED driver; enabled when error condition in charging	
E4	CHG	Digital OUT	Open-drain LED driver; enabled when battery is charging	
E5	MODE	Digital I/O	0 - automatic 1 - Forced PWM	

Table 20: Pin assignments

Note: **VOUTBSET1** and **VOUTBSET0** balls are located close to **AVSS**, **DEC**, and **VSYS** to allow connection to tracks on the PCB without any via holes.

8.2 Mechanical specifications

The mechanical specifications for the package shows the dimensions in millimeters.

8.2.1 WLCSP 2.075x2.075 mm package

Dimensions in millimeters for the WLCSP 2.075x2.075 mm package.

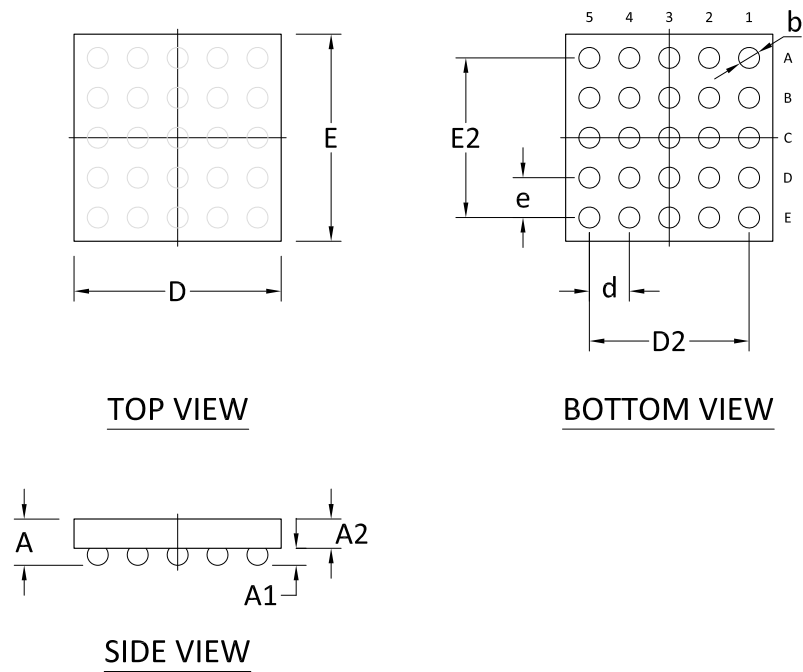

Figure 36: WLCSP 2.075x2.075 mm package

	A	A1	A2	b	D	E	D2	E2	d	e	K	L
Min.	0.406	0.14	0.266	0.195								
Nom.	0.464		0.294		2.075	2.075	1.6	1.6	0.4	0.4		
Max.	0.522	0.2	0.322	0.255								

Table 21: WLCSP dimensions in millimeters

8.3 Reference circuitry

Documentation for the different package reference circuits, including Altium Designer files, PCB layout files, and PCB production files can be downloaded from www.nordicsemi.com.

The following reference circuits for nPM1100 show the schematics and components to support different configurations in a design.

	Configuration 1	Configuration 2	Configuration 3
Description	Minimal configuration Fixed 100 mA VBUS limit	Minimal configuration Fixed 500 mA VBUS limit	Normal configuration USB port detection
BUCK	Not used	Not used	Configured
Ship mode	Not used	Not used	Configured
Battery NTC	Not used	Not used	Configured
V_{TERM}	4.1 V	4.1 V	4.2 V
ISET	AVSS	VSYS	AVSS
D-	AVSS	AVSS	USB
D+	NC	NC	USB
ICHG	4.7 k Ω 1%	0 Ω GND	1.5 Ω GND
VOUTB	-	-	2V1

Table 22: PCB application configuration

8.3.1 Configuration 1

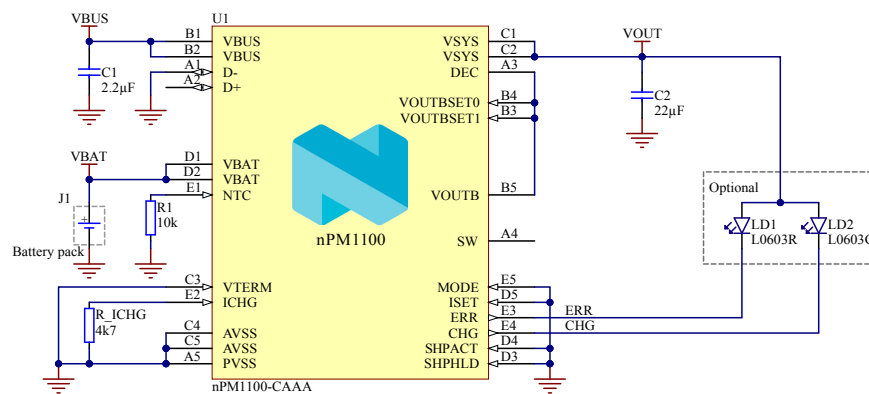

Designator	Value	Description	Footprint
C1	2.2 μ F	Capacitor, X5R, 25 V, \pm 20%	0603
C2	22 μ F	Capacitor, X5R, 6.3 V, \pm 20%	0603
J1	Battery pack	Battery pack	TP_2x1mm_TH
LD1	L0603R	LED, SMD, 0603, RED	0603
LD2	L0603G	LED, SMD, 0603, GREEN	0603
R1	10 K	Resistor, 0.05 W, \pm 1%	0201
R_ICHG	4.7 k Ω	Resistor, 0.05 W, \pm 1%	0201
U1	nPM1100-CAAA	Li-ion/Li-poly USB battery charger with high efficiency buck regulator	WLCSP-25

Table 23: Configuration 1 reference circuitry

8.3.2 Configuration 2

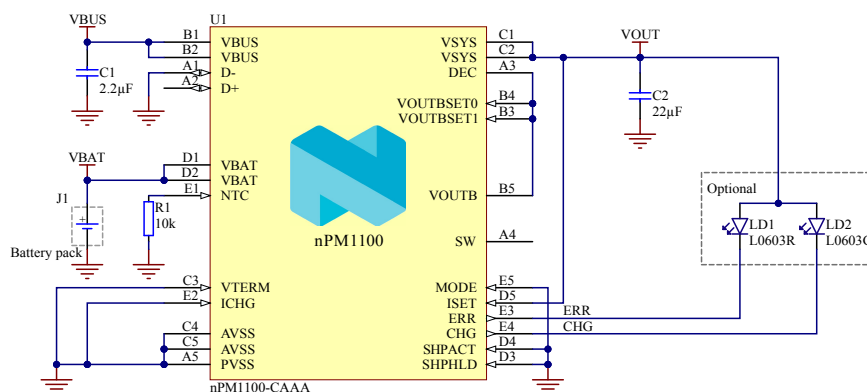

Designator	Value	Description	Footprint
C1	2.2 μ F	Capacitor, X5R, 25 V, \pm 20%	0603
C2	22 μ F	Capacitor, X5R, 6.3 V, \pm 20%	0603
J1	Battery pack	Battery pack	TP_2x1mm_TH
LD1	L0603R	LED, SMD, 0603, RED	0603
LD2	L0603G	LED, SMD, 0603, GREEN	0603
R1	10 K	Resistor, 0.05 W, \pm 1%	0201
U1	nPM1100-CAAA	Li-ion/Li-poly USB battery charger with a high efficiency buck regulator	WLCSP-25

Table 24: Configuration 2 reference circuitry

8.3.3 Configuration 3

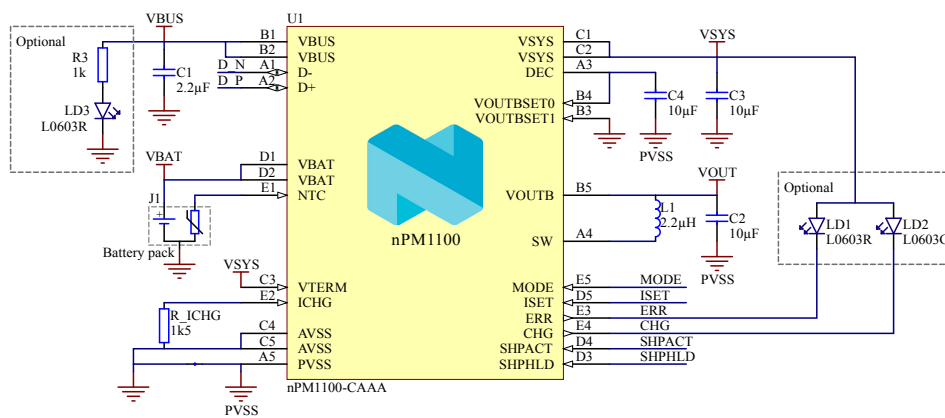

Designator	Value	Description	Footprint
C1	2.2 μ F	Capacitor, X5R, 25 V, \pm 20%	0603
C2, C3, C4	10 μ F	Capacitor, X5R, 6.3 V, \pm 20%	0603
J1	Battery pack	Battery pack with NTC	TP_3x1mm_TH
L1	2.2 μ H	Inductor \pm 20%	0806
LD1, LD3	L0603R	LED, SMD, 0603, RED	0603
LD2	L0603G	LED, SMD, 0603, GREEN	0603
R3	1 K	Resistor, 0.05 W, \pm 1%	0201
R_ICHG	1K5	Resistor, 0.05 W, \pm 1%	0201
U1	nPM1100-CAAA	Li-ion/Li-poly USB battery charger with a high efficiency buck regulator	WLCSP-25

Table 25: Configuration 3 reference circuitry

8.3.4 PCB guidelines

A well designed PCB is necessary to achieve good performance. A poor layout can lead to loss in performance or functionality.

To ensure functionality, it is essential to follow the schematics and layout references closely.

A PCB with a minimum of two layers, including a ground plane, is recommended for optimal performance.

The DC supply voltage should be decoupled with high performance capacitors as close as possible to the supply pins. See the reference schematics [Schematic nPM1100 WLCSP25](#) for recommended decoupling capacitor values.

Long power supply lines on the PCB should be avoided. All device grounds, VDD connections, and VDD bypass capacitors must be connected as close as possible to the device.

8.3.5 PCB layout example

The PCB layout shown here is a reference layout for the WLCSP25 package.

For all available reference layouts, see the Reference Layout section on the Downloads tab for nPM1100 on www.nordicsemi.com.

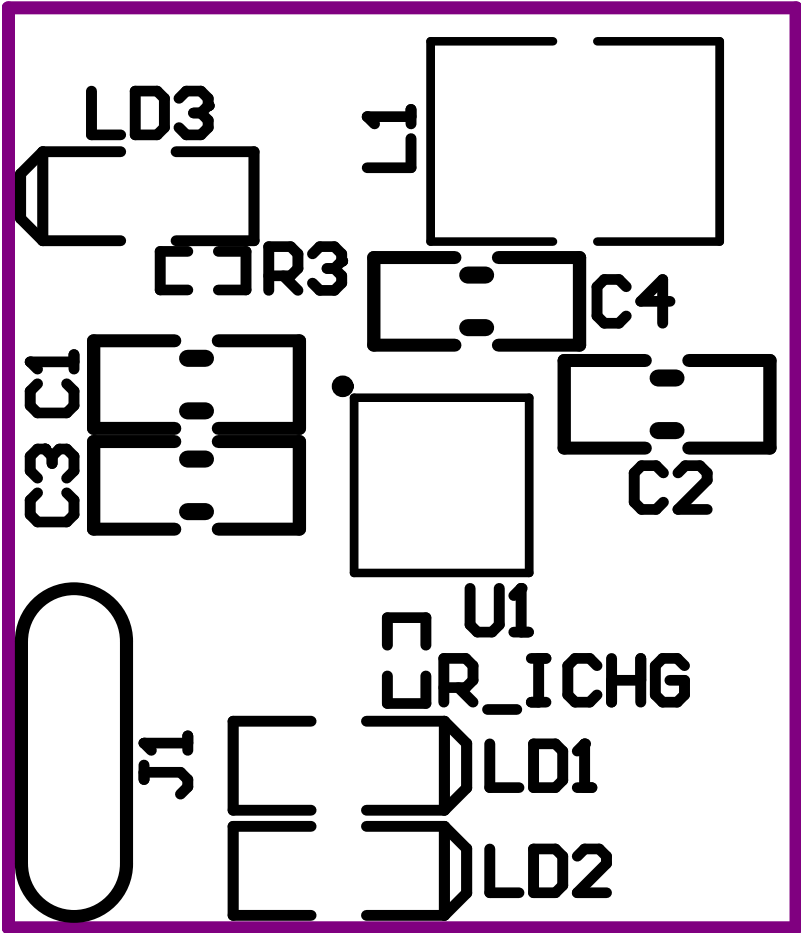

Figure 37: Top silk layer

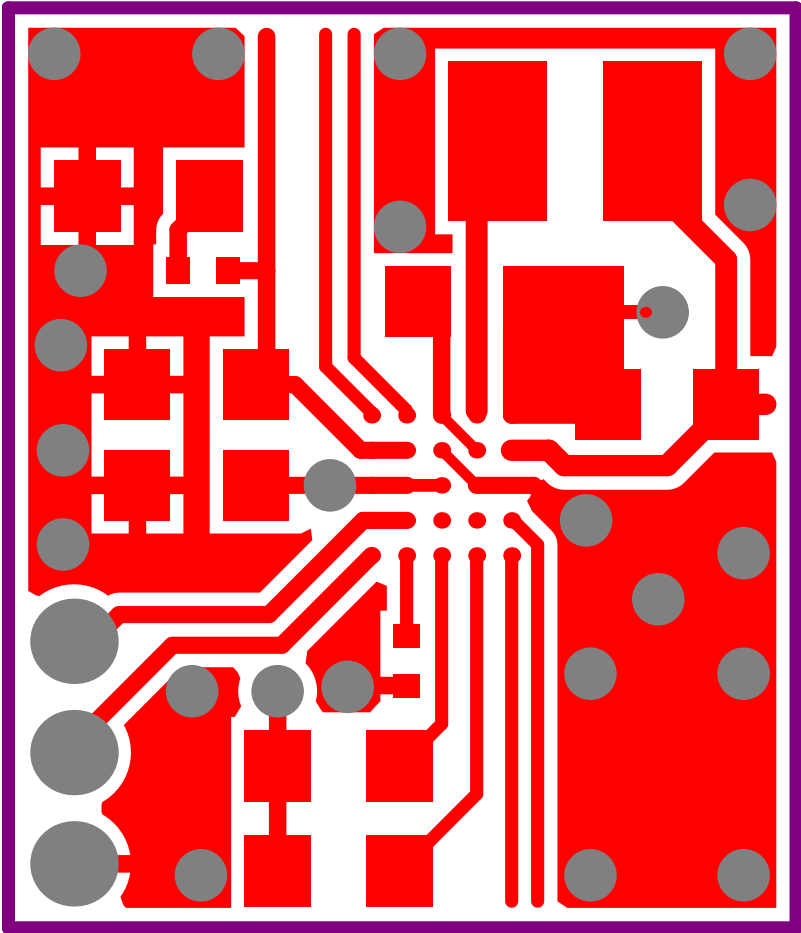

Figure 38: Top layer

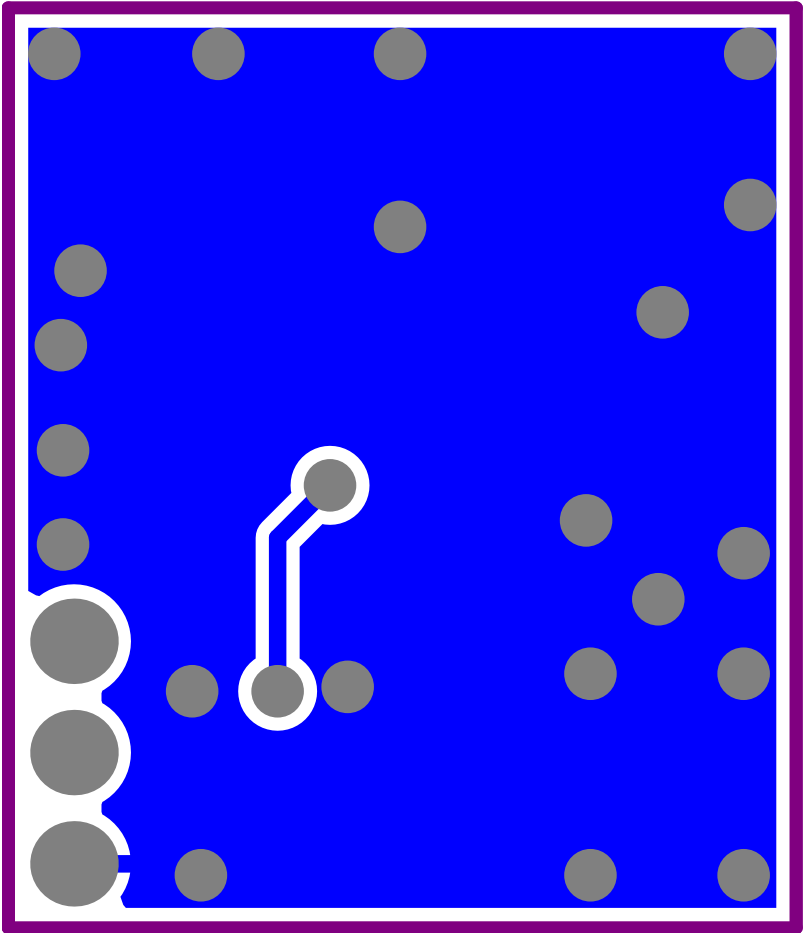

Figure 39: Bottom layer

Note: No components in the bottom layer.

9 Ordering information

This chapter contains information on IC marking, ordering codes, and container sizes.

9.1 IC marking

The nPM1100 PMIC package is marked as shown in the following figure.

N	P	M	1	1	0	0
<P>	P>	<V>	V>	<H>	<P>	
<Y>	Y>	<W>	W>	<L>	L>	

Figure 40: IC marking

9.2 Box labels

The following figures define the box labels used for the nPM1100.

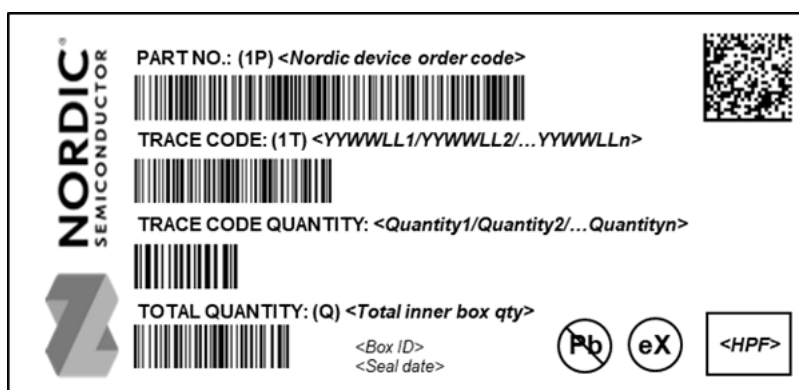

Figure 41: Inner box label

Figure 42: Outer box label

9.3 Order code

The following tables define the nPM1100 order codes and definitions.

n	P	M	1	1	0	0	-	<P	P>	<V	V>	-	<C	C>
---	---	---	---	---	---	---	---	----	----	----	----	---	----	----

Figure 43: Order code

Abbreviation	Definition and implemented codes
N11/nPM11	nPM11 series product
00	Part code
<PP>	Package variant code
<VV>	Function variant code
<H><P><F>	Build code H - Hardware version code P - Production configuration code (production site, etc.) F - Firmware version code (only visible on shipping container label)
<YY><WW><LL>	Tracking code YY - Year code WW - Assembly week number LL - Wafer lot code
<CC>	Container code
eX	2 nd level Interconnect Symbol where value of X is based on J-STD-609

Table 26: Abbreviations

9.4 Code ranges and values

The following tables define the nPM1100 code ranges and values.

<PP>	Package	Size (mm)	Pin/Ball count	Pitch (mm)
CA	WLCSP	2.075x2.075	25	0.4

Table 27: Package variant codes

<VV>	Flash (kB)	RAM (kB)
AA	n/a	n/a

Table 28: Function variant codes

<H>	Description
[A . . Z]	Hardware version/revision identifier (incremental)

Table 29: Hardware version codes

<P>	Description
[0 . . 9]	Production device identifier (incremental)
[A . . Z]	Engineering device identifier (incremental)

Table 30: Production configuration codes

<F>	Description
[A . . N, P . . Z]	Version of preprogrammed firmware
[0]	Delivered without preprogrammed firmware

Table 31: Production version codes

<YY>	Description
[16 . . 99]	Production year: 2016 to 2099

Table 32: Year codes

<WW>	Description
[1 . . 52]	Week of production

Table 33: Week codes

<LL>	Description
[AA . . ZZ]	Wafer production lot identifier

Table 34: Lot codes

<CC>	Description
R7	7" Reel
R	13" Reel

Table 35: Container codes

9.5 Product options

The following tables define the nPM1100 product options.

Order code	MOQ ¹	Comment
nPM1100-CAAA-R	MoQ 7000 pcs	Availability to be announced
nPM1100-CAAA-R7	MoQ 1500 pcs	

Table 36: nPM1100 order codes

Order code	Description
nPM1100-EK	Evaluation kit

Table 37: Development tools order code

¹ Minimum Ordering Quantity

10 Legal notices

By using this documentation you agree to our terms and conditions of use. Nordic Semiconductor may change these terms and conditions at any time without notice.

Liability disclaimer

Nordic Semiconductor ASA reserves the right to make changes without further notice to the product to improve reliability, function, or design. Nordic Semiconductor ASA does not assume any liability arising out of the application or use of any product or circuits described herein.

Nordic Semiconductor ASA does not give any representations or warranties, expressed or implied, as to the accuracy or completeness of such information and shall have no liability for the consequences of use of such information. If there are any discrepancies, ambiguities or conflicts in Nordic Semiconductor's documentation, the Product Specification prevails.

Nordic Semiconductor ASA reserves the right to make corrections, enhancements, and other changes to this document without notice.

Customer represents that, with respect to its applications, it has all the necessary expertise to create and implement safeguards that anticipate dangerous consequences of failures, monitor failures and their consequences, and lessen the likelihood of failures that might cause harm, and to take appropriate remedial actions.

Nordic Semiconductor ASA assumes no liability for applications assistance or the design of customers' products. Customers are solely responsible for the design, validation, and testing of its applications as well as for compliance with all legal, regulatory, and safety-related requirements concerning its applications.

Nordic Semiconductor ASA's products are not designed for use in life-critical medical equipment, support appliances, devices, or systems where malfunction of Nordic Semiconductor ASA's products can reasonably be expected to result in personal injury. Customer may not use any Nordic Semiconductor ASA's products in life-critical medical equipment unless adequate design and operating safeguards by customer's authorized officers have been made. Customer agrees that prior to using or distributing any life-critical medical equipment that include Nordic Semiconductor ASA's products, customer will thoroughly test such systems and the functionality of such products as used in such systems.

Customer will fully indemnify Nordic Semiconductor ASA and its representatives against any damages, costs, losses, and/or liabilities arising out of customer's non-compliance with this section.

RoHS and REACH statement

Refer to for complete hazardous substance reports, material composition reports, and latest version of Nordic's RoHS and REACH statements.

Trademarks

All trademarks, service marks, trade names, product names, and logos appearing in this documentation are the property of their respective owners.

Copyright notice

© Nordic Semiconductor ASA. All rights are reserved. Reproduction in whole or in part is prohibited without the prior written permission of the copyright holder.

**COMPANY WITH
QUALITY SYSTEM
CERTIFIED BY DNV GL
= ISO 9001 =**