

# NB6L295

## 2.5V / 3.3V Dual Channel Programmable Clock/Data Delay with Differential LVPECL Outputs

### Multi-Level Inputs w/ Internal Termination

The NB6L295 is a Dual Channel Programmable Delay Chip designed primarily for Clock or Data de-skewing and timing adjustment. The NB6L295 is versatile in that two individual variable delay channels, PD0 and PD1, can be configured in one of two operating modes, a Dual Delay or an Extended Delay.

In the Dual Delay Mode, each channel has a programmable delay section which is designed using a matrix of gates and a chain of multiplexers. There is a fixed minimum delay of 3.2 ns per channel.

The Extended Delay Mode amounts to the additive delay of PD0 plus PD1 and is accomplished with the Serial Data Interface MSEL bit set High. This will internally cascade the output of PD0 into the input of PD1. Therefore, the Extended Delay path starts at the IN0/ $\overline{IN0}$  inputs, flows through PD0, cascades to the PD1 and outputs through Q1/ $\overline{Q1}$ . There is a fixed minimum delay of 6 ns for the Extended Delay Mode.

The required delay is accomplished by programming each delay channel via a 3-pin Serial Data Interface, described in the application section. The digitally selectable delay has an increment resolution of typically 11 ps with a net programmable delay range of either 0 ns to 6 ns per channel in Dual Delay Mode; or from 0 ns to 11.2 ns for the Extended Delay Mode.

The Multi-Level Inputs can be driven directly by differential LVPECL, LVDS or CML logic levels; or by single ended LVPECL, LVCMOS or LVTTL. A single enable pin is available to control both inputs. The SDI input pins are controlled by LVCMOS or LVTTL level signals. The NB6L295 LVPECL output contains temperature compensation circuitry. This device is offered in a 4 mm x 4 mm 24-pin QFN Pb-free package. The NB6L295 is a member of the ECLinPS MAX™ family of high performance products.

### Features

- Input Clock Frequency > 1.5 GHz with 550 mV  $V_{OUTPP}$
- Input Data Rate > 2.5 Gb/s
- Programmable Delay Range: 0 ns to 6 ns per Delay Channel
- Programmable Delay Range: 0 ns to 11.2 ns for Extended Delay Mode
- Total Delay Range: 3.2 ns to 8.8 ns per Delay Channel
- Total Delay Range: 6 ns to 17 ns in Extended Delay Mode
- Monotonic Delay: 11 ps Increments in 511 Steps
- Linearity  $\pm 20$  ps, Maximum
- 100 ps Typical Rise and Fall Times

\*For additional information on our Pb-Free strategy and soldering details, please download the ON Semiconductor Soldering and Mounting Techniques Reference Manual, SOLDERRM/D.



ON Semiconductor®

<http://onsemi.com>

### MARKING DIAGRAM\*

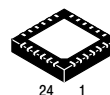

QFN-24  
MN SUFFIX  
CASE 485L

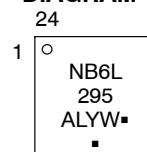

- A = Assembly Location
  - L = Wafer Lot
  - Y = Year
  - W = Work Week
  - = Pb-Free Package
- (Note: Microdot may be in either location)

\*For additional marking information, refer to Application Note AND8002/D.

### ORDERING INFORMATION

See detailed ordering and shipping information in the package dimensions section on page 12 of this data sheet.

- 3 ps Typical Clock Jitter, RMS
- 20 ps Pk-Pk Typical Data Dependent Jitter
- LVPECL, CML or LVDS Differential Input Compatible
- LVPECL, LVCMOS, LVTTL Single-Ended Input Compatible
- 3-Wire Serial Interface
- Input Enable/Disable
- Operating Range:  $V_{CC} = 2.375$  V to 3.6 V
- LVPECL Output Level; 780 mV Peak-to-Peak, Typical
- Internal 50  $\Omega$  Input Termination Provided
- -40°C to 85°C Ambient Operating Temperature
- 24-Pin QFN, 4 mm x 4 mm
- These are Pb-Free Devices\*

# NB6L295



Figure 1. Simplified Functional Block Diagram

# NB6L295

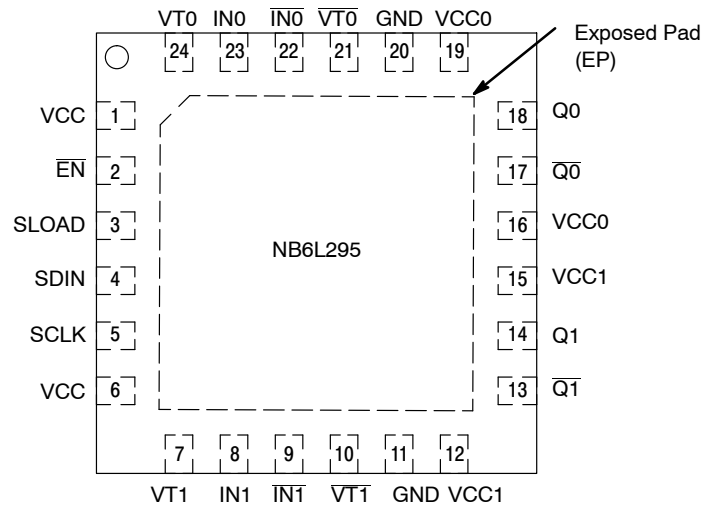

Figure 2. Pinout: QFN-24 (Top View)

Table 1. PIN DESCRIPTION

Pin	Name	I/O	Description
1	VCC	Power Supply	Positive Supply Voltage for the Inputs and Core Logic
2	EN	LVC MOS/LVTTL Input	Input Enable/Disable for both PD0 and PD1. LOW for enable, HIGH for disable, Open Pin Default state LOW (37 kΩ pull-down resistor). High forces Q LOW and Q̄ HIGH.
3	SLOAD	LVC MOS/LVTTL Input	Serial Load; This pin loads the configuration latches with the contents of the shift register. The latches will be transparent when this signal is HIGH; thus, the data must be stable on the HIGH-to-LOW transition of S_LOAD for proper operation. Open Pin Default state LOW (37 kΩ pull-down resistor).
4	SDIN	LVC MOS/LVTTL Input	Serial Data In; This pin acts as the data input to the serial configuration shift register. Open Pin Default state LOW (37 kΩ pull-down resistor).
5	SCLK	LVC MOS/LVTTL Input	Serial Clock In; This pin serves to clock the serial configuration shift register. Data from SDIN is sampled on the rising edge. Open Pin Default state LOW (37 kΩ pull-down resistor).
6	VCC	Power Supply	Positive Supply Voltage for the Inputs and Core Logic
7	VT1		Internal 50 Ω Termination Pin for IN1
8	IN1	LVPECL, CML, LVDS Input	Non-inverted differential input. Note 1.
9	IN1	LVPECL, CML, LVDS Input	Inverted differential input. Note 1.
10	VT1		Internal 50 Ω Termination Pin for IN1
11	GND	Power Supply	Negative Power Supply
12	VCC1	Power Supply	Positive Supply Voltage for the Q1/Q̄1 outputs, channel PD1
13	Q1	LVPECL Output	Inverted Differential Output. Channel 1. Typically terminated with 50 Ω resistor to VCC1 - 2.0 V.
14	Q1	LVPECL Output	Non-inverted Differential Output. Channel 1. Typically terminated with 50 Ω resistor to VCC1 - 2.0 V.
15	VCC1	Power Supply	Positive Supply Voltage for the Q1/Q̄1 outputs, channel PD1
16	VCC0	Power Supply	Positive Supply Voltage for the Q0/Q̄0 outputs, channel PD0
17	Q0	LVPECL Output	Inverted Differential Output. Channel 0. Typically terminated with 50 Ω resistor to VCC0 - 2.0 V.
18	Q0	LVPECL Output	Non-inverted Differential Output. Channel 0. Typically terminated with 50 Ω resistor to VCC0 - 2.0 V.
19	VCC0	Power Supply	Positive Supply Voltage for the Q0/Q̄0 outputs, channel PD0
20	GND	Power Supply	Negative Power Supply
21	VT0		Internal 50 Ω Termination Pin for IN0
22	IN0	LVPECL, CML, LVDS Input	Inverted differential input. Note 1.
23	IN0	LVPECL, CML, LVDS Input	Noninverted differential input. Note 1.
24	VT0		Internal 50 Ω Termination Pin for IN0
-	EP	Ground	The Exposed Pad (EP) on the QFN-24 package bottom is thermally connected to the die for improved heat transfer out of package. The exposed pad must be attached to a heat-sinking conduit. The pad is electrically connected to GND and must be connected to GND on the PC board.

1. In the differential configuration when the input termination pin (VT<sub>x</sub>/VT̄<sub>x</sub>) are connected to a common termination voltage or left open, and if no signal is applied on IN<sub>x</sub>/IN̄<sub>x</sub> input then the device will be susceptible to self-oscillation.
2. All VCC, VCC0 and VCC1 Pins must be externally connected to the same power supply for proper operation. Both VCC0s are connected to each other and both VCC1s are connected to each other: VCC0 and VCC1 are separate.

# NB6L295

**Table 2. ATTRIBUTES**

Characteristics		Value
Input Default State Resistors		37 kΩ
ESD Protection	Human Body Model Machine Model	> 2 kV > 100V
Moisture Sensitivity (Note 3)	QFN-24	Level 1
Flammability Rating	Oxygen Index: 28 to 34	UL 94 V-0 @ 0.125 in
Transistor Count		3094
Meets or exceeds JEDEC Spec EIA/JESD78 IC Latchup Test		

3. For additional information, see Application Note AND8003/D.

**Table 3. MAXIMUM RATINGS**

Symbol	Parameter	Condition 1	Condition 2	Rating	Unit
$V_{CC}, V_{CC0}, V_{CC1}$	Positive Power Supply	GND = 0 V		4.0	V
$V_{IO}$	Positive Input/Output Voltage	GND = 0 V	$-0.5 \leq V_{IO} \leq V_{CC} + 0.5$	4.5	V
$V_{INPP}$	Differential Input Voltage $ I_{Nx} - \overline{I_{Nx}} $			$V_{CC} - GND$	V
$I_{IN}$	Input Current Through $R_T$ (50 Ω Resistor)			± 50	mA
$I_{OUT}$	Output Current (LVPECL Output)	Continuous Surge		50 100	mA mA
$T_A$	Operating Temperature Range			-40 to +85	°C
$T_{stg}$	Storage Temperature Range			-65 to +150	°C
$\theta_{JA}$	Thermal Resistance (Junction-to-Ambient) (Note 4)	0 lfpm 500 lfpm	QFN-24 QFN-24	37 32	°C/W °C/W
$\theta_{JC}$	Thermal Resistance (Junction-to-Case)	(Note 4)	QFN-24	11	°C/W
$T_{sol}$	Wave Solder Pb-Free			265	°C

Stresses exceeding Maximum Ratings may damage the device. Maximum Ratings are stress ratings only. Functional operation above the Recommended Operating Conditions is not implied. Extended exposure to stresses above the Recommended Operating Conditions may affect device reliability.

4. JEDEC standard multilayer board – 2S2P (2 signal, 2 power) with 8 filled thermal vias under exposed pad.

# NB6L295

**Table 4. DC CHARACTERISTICS, MULTI-LEVEL INPUTS**  $V_{CC} = V_{CC0} = V_{CC1} = 2.375\text{ V to }3.6\text{ V}$ ,  $GND = 0\text{ V}$ ,  $T_A = -40^\circ\text{C to }+85^\circ\text{C}$

Symbol	Characteristic	Min	Typ	Max	Unit
--------	----------------	-----	-----	-----	------

### POWER SUPPLY CURRENT

$I_{CC}$	Power Supply Current (Inputs, $V_{TX}$ and Outputs Open) (Sum of $I_{CC}$ , $I_{CC0}$ , and $I_{CC1}$ )	110	140	170	mA
----------	---	-----	-----	-----	----

### LVPECL OUTPUTS (Notes 5 and 6, Figure 21)

$V_{OH}$	Output HIGH Voltage $V_{CC} = V_{CC0} = V_{CC1} = 3.3\text{ V}$ $V_{CC} = V_{CC0} = V_{CC1} = 2.5\text{ V}$	$V_{CC} - 1075$ 2225 1425	$V_{CC} - 950$ 2350 1550	$V_{CC} - 825$ 2475 1675	mV
$V_{OL}$	Output LOW Voltage $V_{CC} = V_{CC0} = V_{CC1} = 3.3\text{ V}$ $V_{CC} = V_{CC0} = V_{CC1} = 2.5\text{ V}$	$V_{CC} - 1825$ 1475	$V_{CC} - 1725$ 1575	$V_{CC} - 1625$ 1675	mV
		$V_{CC} - 1825$ 675	$V_{CC} - 1725$ 775	$V_{CC} - 1600$ 900	

### DIFFERENTIAL INPUT DRIVEN SINGLE-ENDED (see Figures 10 and 11) (Note 7)

$V_{th}$	Input Threshold Reference Voltage Range	1050		$V_{CC} - 150$	mV
$V_{IH}$	Single-Ended Input HIGH Voltage	$V_{th} + 150$		$V_{CC}$	mV
$V_{IL}$	Single-Ended Input LOW Voltage	GND		$V_{th} - 150$	mV
$V_{ISE}$	Single-Ended Input Voltage Amplitude ( $V_{IH} - V_{IL}$ )	300		$V_{CC} - GND$	mV

### DIFFERENTIAL INPUTS DRIVEN DIFFERENTIALLY (see Figures 12 and 13) (Note 8)

$V_{IHD}$	Differential Input HIGH Voltage	1200		$V_{CC}$	mV
$V_{ILD}$	Differential Input LOW Voltage	GND		$V_{CC} - 150$	mV
$V_{ID}$	Differential Input Voltage Swing ( $I_{NX}, \bar{I}_{NX}$ ) ( $V_{IHD} - V_{ILD}$ )	150		$V_{CC} - GND$	mV
$V_{CMR}$	Input Common Mode Range (Differential Configuration) (Note 9)	950		$V_{CC} - 75$	mV
$I_{IH}$	Input HIGH Current $I_{NX}/\bar{I}_{NX}$ , ( $V_{Tn}/V_{Tp}$ Open)	-150		150	$\mu\text{A}$
$I_{IL}$	Input LOW Current $I_N/\bar{I}_X$ , ( $V_{Tn}/V_{Tp}$ Open)	-150		150	$\mu\text{A}$

### SINGLE-ENDED LVCMOS/LVTTL CONTROL INPUTS

$V_{IH}$	Single-Ended Input HIGH Voltage	2000		$V_{CC}$	mV
$V_{IL}$	Single-Ended Input LOW Voltage	GND		800	mV
$I_{IH}$	Input HIGH Current	-150		150	$\mu\text{A}$
$I_{IL}$	Input LOW Current	-150		150	$\mu\text{A}$

### TERMINATION RESISTORS

$R_{TIN}$	Internal Input Termination Resistor	40	50	60	$\Omega$
-----------	-------------------------------------	----	----	----	----------

NOTE: Device will meet the specifications after thermal equilibrium has been established when mounted in a test socket or printed circuit board with maintained transverse airflow greater than 500 lfm. Electrical parameters are guaranteed only over the declared operating temperature range. Functional operation of the device exceeding these conditions is not implied. Device specification limit values are applied individually under normal operating conditions and not valid simultaneously.

- LVPECL outputs loaded with  $50\ \Omega$  to  $V_{CC} - 2.0\text{ V}$  for proper operation.
- Input and output parameters vary 1:1 with  $V_{CC}$ .
- $V_{th}$ ,  $V_{IH}$ ,  $V_{IL}$ , and  $V_{ISE}$  parameters must be complied with simultaneously.  $V_{th}$  is applied to the complementary input when operating in single-ended mode.
- $V_{IHD}$ ,  $V_{ILD}$ ,  $V_{ID}$  and  $V_{CMR}$  parameters must be complied with simultaneously.
- $V_{CMR}(\text{min})$  varies 1:1 with voltage on GND Pin,  $V_{CMR}(\text{max})$  varies 1:1 with  $V_{CC}$ . The  $V_{CMR}$  range is referenced to the most positive side of the differential input signal.

# NB6L295

**Table 5. AC CHARACTERISTICS**  $V_{CC} = V_{CC0} = V_{CC1} = 2.375\text{ V to }3.6\text{ V}$ ,  $GND = 0\text{ V}$ ,  $T_A = -40^\circ\text{C to }+85^\circ\text{C}$  (Note 10)

Symbol	Characteristic	Min	Typ	Max	Unit						
$f_{SCLK}$	Serial Clock Input Frequency, 50% Duty Cycle			20	MHz						
$V_{OUTPP}$	Output Voltage Amplitude (@ $V_{INPPmin}$ ) $f_{in} \leq 1.5\text{ GHz}$ (Note 15) (See Figure 22)	530	780		mV						
$f_{DATA}$	Maximum Data Rate (Note 14)	2.5			Gb/s						
$t_{Range}$	Programmable Delay Range (@ 50 MHz) Dual Mode $IN0/\overline{IN0}$ to $Q0/\overline{Q0}$ or $IN1/\overline{IN1}$ to $Q1/\overline{Q1}$ Extended Mode $IN0/\overline{IN0}$ to $Q1/\overline{Q1}$	0 0	5.7 11.2	6.9 13.7	ns						
$t_{SKEW}$	Duty Cycle Skew (Note 11) Within Device Skew – Dual Mode $D[8:0] = 0$ $D[8:0] = 1$	0	2 60 60	5 100 175	ps						
$L_{in}$	Linearity (Note 12)		$\pm 15$	$\pm 20$	ps						
$t_s$	Setup Time (@ 20 MHz) SDIN to SCLK SLOAD to SCLK EN to SDIN	0.5 1.5 0.5	0.3 1.0		ns						
$t_h$	Hold Time SDIN to SCLK SLOAD to SCLK EN to SLOAD	1.0 1.0 0.5	0.6		ns						
$t_{pmin}$	Minimum Pulse Width SLOAD	1			ns						
$t_{JITTER}$	Random Clock Jitter RMS; SETMIN to SETMAX (Note 13) $f_{in} \leq 1.5\text{ GHz}$ Dual Mode $IN0/\overline{IN0}$ to $Q0/\overline{Q0}$ or $IN1/\overline{IN1}$ to $Q1/\overline{Q1}$ Extended Mode $IN0/\overline{IN0}$ to $Q1/\overline{Q1}$ Deterministic Jitter; SETMIN to SETMAX (Note 14) $f_{DAT} \leq 2.5\text{ Gbps}$ Dual Mode $IN0/\overline{IN0}$ to $Q0/\overline{Q0}$ or $IN1/\overline{IN1}$ to $Q1/\overline{Q1}$		3 6 20	10 20 30	ps						
$V_{INPP}$	Input Voltage Swing/Sensitivity (Differential Configuration) (Note 15)	150		$V_{CC} - GND$	mV						
$t_r, t_f$	Output Rise/Fall Times (@ 50 MHz), (20% – 80%) $Q_x$ , $\overline{Q_x}$	85	120	170	ps						
Symbol	Characteristic	-40°C			+25°C			+85°C			Unit
		Min	Typ	Max	Min	Typ	Max	Min	Typ	Max	
$t_{PLH}, t_{PHL}$	Propagation Delay (@ 50 MHz) Dual Mode $IN0/\overline{IN0}$ to $Q0/\overline{Q0}$ or $IN1/\overline{IN1}$ to $Q1/\overline{Q1}$ $D[8:0] = 0$ $D[8:0] = 1$  Extended Mode $IN0/\overline{IN0}$ to $Q1/\overline{Q1}$ $D[8:0] = 0$ $D[8:0] = 1$	2.7 7.2	2.9 8.0	3.2 8.8	2.8 7.5	3.1 8.4	3.4 9.3	2.9 7.9	3.2 9.2	3.6 9.9	ns
$\Delta t$	Step Delay (Selected D Bit HIGH All Others LOW)  D0 HIGH D1 HIGH D2 HIGH D3 HIGH D4 HIGH D5 HIGH D6 HIGH D7 HIGH D8 HIGH		9.6 19.4 40 81 167 338 678 1358 2715			8.7 19 42 85 175 355 714 1432 2861			11 24.4 52 99 196 389 774 1544 3074		ps

NOTE: Device will meet the specifications after thermal equilibrium has been established when mounted in a test socket or printed circuit board with maintained transverse airflow greater than 500 lpm. Electrical parameters are guaranteed only over the declared operating temperature range. Functional operation of the device exceeding these conditions is not implied. Device specification limit values are applied individually under normal operating conditions and not valid simultaneously.

10. Measured by forcing  $V_{INPPmin}$  and  $V_{INPPmax}$  from a 50% duty cycle clock source,  $V_{CMR}$  (min and max). All loading with an external  $R_L = 50\ \Omega$  to  $V_{CC}$ . See Figure 20. Input edge rates 40 ps (20% – 80%).

11. Duty cycle skew is measured between differential outputs using the deviations of the sum of  $T_{pw-}$  and  $T_{pw+}$  @ 0.5 GHz.

12. Deviation from a linear delay (actual Min to Max) in the Dual Mode 511 programmable steps.

13. Additive random CLOCK jitter with 50% duty cycle input clock signal.

14. NRZ data at PRBS23 and K28.5.

15. Input and output voltage swing is a single-ended measurement operating in differential mode.

**Serial Data Interface Programming**

The NB6L295 is programmed by loading the 11–Bit SHIFT REGISTER using the SCLK, SDATA and SLOAD inputs. The 11 SDATA bits are 1 PSEL bit, 1 MSEL bit and 9 delay value data bits D[8:0]. A separate 11–bit load cycle is required to program the delay data value of each channel, PD0 and PD1. For example, at powerup two load cycles will be needed to initially set PD0 and PD1; Dual Mode Operation as shown in Figures 3 and 4 and Extended Mode Operation as shown in Figures 5 and 6.

**DUAL MODE OPERATIONS**

PD0 Programmable Delay									Control Bits		Value
0/1	0/1	0/1	0/1	0/1	0/1	0/1	0/1	0/1	0	0	
D8	D7	D6	D5	D4	D3	D2	D1	D0	MSEL	PSEL	Bit Name
(MSB)									(LSB)		

**Figure 3. PDO Shift Register**

PD1 Programmable Delay									Control Bits		Value
0/1	0/1	0/1	0/1	0/1	0/1	0/1	0/1	0/1	0	1	
D8	D7	D6	D5	D4	D3	D2	D1	D0	MSEL	PSEL	Bit Name
(MSB)									(LSB)		

**Figure 4. PD1 Shift Register**

**EXTENDED MODE OPERATIONS**

PD0 Programmable Delay									Control Bits		Value
0/1	0/1	0/1	0/1	0/1	0/1	0/1	0/1	0/1	1	0	
D8	D7	D6	D5	D4	D3	D2	D1	D0	MSEL	PSEL	Bit Name
(MSB)									(LSB)		

**Figure 5. PDO Shift Register**

PD1 Programmable Delay									Control Bits		Value
0/1	0/1	0/1	0/1	0/1	0/1	0/1	0/1	0/1	1	1	
D8	D7	D6	D5	D4	D3	D2	D1	D0	MSEL	PSEL	Bit Name
(MSB)									(LSB)		

**Figure 6. PD1 Shift Register**

Refer to Table 6, Channel and Mode Select BIT Functions. In a load cycle, the 11–Bit Shift Register least significant bit (clocked in first) is **PSEL** and will determine which channel delay buffer, either PD0 (LOW) or PD1 (HIGH), will latch the delay data value D[8:0]. The **MSEL BIT** determines the Delay Mode. When set LOW, the Dual Delay Mode is selected and the device uses both channels independently. A pulse edge entering IN0/ $\overline{IN0}$  is delayed according to the values in PD0 and exits from Q0/ $\overline{Q0}$ . An input signal pulse edge entering IN1/ $\overline{IN1}$  is delayed according to the values in PD1 and exits from Q1/ $\overline{Q1}$ . When MSEL is set HIGH, the Extended Delay Mode is selected and an input signal pulse edge enters IN0 and  $\overline{IN0}$  and flows through PD0 and is extended through PD1 to exit at Q1 and  $\overline{Q1}$ . The most significant 9–bits, D[8:0] are delay value data for both channels. See Figure 7.

**Table 6. CHANNEL AND MODE SELECT BIT FUNCTIONS**

BIT Name	Function
PSEL	0 Loads Data to PD0
	1 Loads Data to PD1
MSEL	0 Selects Dual Programmable Delay Paths, 3.1 ns to 8.8 ns Delay Range for Each Path
	1 Selects Extended Delay Path from IN0/ $\overline{IN0}$ to Q1/ $\overline{Q1}$ , 6.0 ns to 17.2 ns Delay Range; Disables Q0/ $\overline{Q0}$ Outputs, Q0–LOW, $\overline{Q0}$ –HIGH.
D[8:0]	Select one of 512 Delay Values

## NB6L295

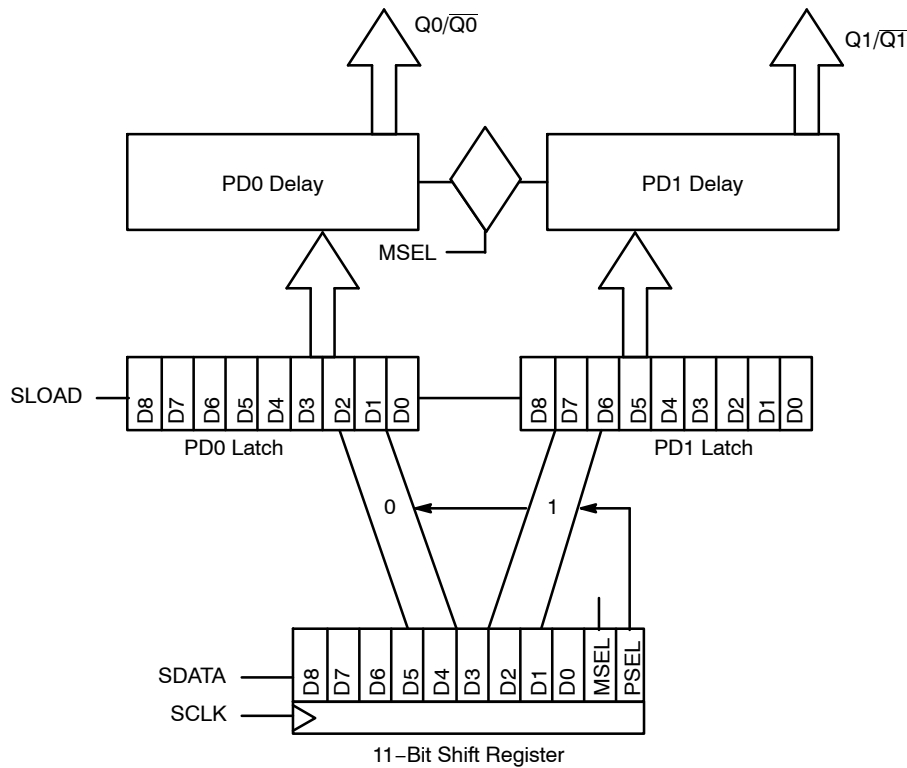

**Figure 7. Serial Data Interface, Shift Register, Data Latch, Programmable Delay Channels**

### Serial Data Interface Loading

Loading the device through the 3 input Serial Data Interface (SDI) is accomplished by sending data into the SDIN pin by using the SCLK input pin and latching the data with the SLOAD input pin. The 11-bit SHIFT REGISTER shifts once per rising edge of the SCLK input. The serial input SDIN must meet setup and hold timing as specified in the AC Characteristics section of this document for each bit and clock pulse. The SLOAD line loads the value of the shift register on a LOW-to-HIGH edge transition (transparent state) into a data Latch register and latches the data with a subsequent HIGH-to-LOW edge transition. Further changes in SDIN or SCLK are not recognized by the latched register. The internal multiplexer states are set by the PSEL and MSEL bits in the SHIFT register. Figure 6 shows the timing diagram of a typical load sequence.

Input  $\overline{EN}$  should be LOW (enabled) prior to SDI programming, then pulled HIGH (disabled) during programming. After programming, the  $\overline{EN}$  should be returned LOW (enabled) for functional delay operation.

The disabling of  $\overline{EN}$  (HIGH) forces  $Q_x$  LOW and  $\overline{Q}_x$  HIGH and is included during programming to prevent (or mask out) any potential runt pulses or extended pulses which might occur in the internal delay gates programming switching, but it is not required for programming.

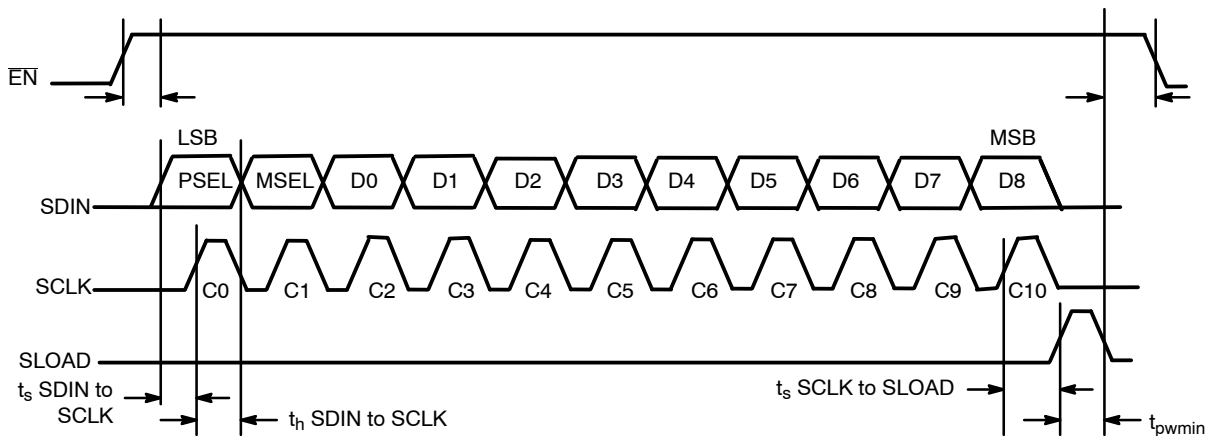

**Figure 8. SDI Timing Diagram**



## NB6L295

Table 7 shows theoretical values of delay capabilities in both the Dual Delay Mode and in the Extended Delay Modes of operation.

**Table 7. EXAMPLES OF THEORETICAL DELAY VALUES FOR PD0 AND PD1 IN DUAL MODE**

INPUTS: IN0/ $\overline{IN0}$ , IN1/ $\overline{IN1}$ , OUTPUTS: Q0/ $\overline{Q0}$ , Q1,  $\overline{Q1}$

Dual Mode				PD0 Delay* (ps)	PD1 Delay* (ps)
PD1 D[8:0]	(Decimal)	PD0 D[8:0]	(Decimal)		
00000000	(0)	00000000	(0)	0	0
00000000	(0)	00000001	(1)	0	11
00000000	(0)	00000010	(2)	0	22
00000000	(0)	00000011	(3)	0	33
00000000	(0)	00000100	(4)	0	44
00000000	(0)	00000101	(5)	0	55
00000000	(0)	00000110	(6)	0	66
00000000	(0)	00000111	(7)	0	77
00000000	(0)	00001000	(8)	0	88
		• • •		• • •	• • •
00000000	(0)	00010000	(16)	0	176
00000000	(0)	00010000	(32)	0	352
00000000	(0)	00100000	(64)	0	704
00000000	(0)	11111101	(509)	0	5599
00000000	(0)	11111110	(510)	0	5610
00000000	(0)	11111111	(511)	0	5621

\*Fixed minimum delay not included

**Table 8. EXAMPLES OF THEORETICAL DELAY VALUES FOR PD0 AND PD1 IN EXTENDED MODE**

INPUTS: IN0/ $\overline{IN0}$ , IN1/ $\overline{IN1}$ , OUTPUTS: Q0/ $\overline{Q0}$ , Q1,  $\overline{Q1}$

Extended Delay Mode				PD0* (ps)	PD1* (ps)	Total Delay* (ps)
PD1 D[8:0]	(Decimal)	PD0 D[8:0]	(Decimal)			
00000000	(0)	00000000	(0)	1	0	0
00000000	(0)	00000001	(1)	1	0	11
00000000	(0)	00000010	(2)	1	0	22
00000000	(0)	00000011	(3)	1	0	33
		• • •			• • •	• • •
00000000	(0)	11111101	(509)	1	0	5599
00000000	(0)	11111110	(510)	1	0	5610
00000000	(0)	11111111	(511)	1	0	5621
00000001	(1)	11111111	(511)	1	11	5632
00000010	(2)	11111111	(511)	1	22	5643
		• • •			• • •	• • •
11111100	(508)	11111111	(511)	1	5588	5621
11111101	(509)	11111111	(511)	1	5599	5621
11111110	(510)	11111111	(511)	1	5610	5621
11111111	(511)	11111111	(511)	1	5621	5621

\*Fixed minimum delay not included

# NB6L295

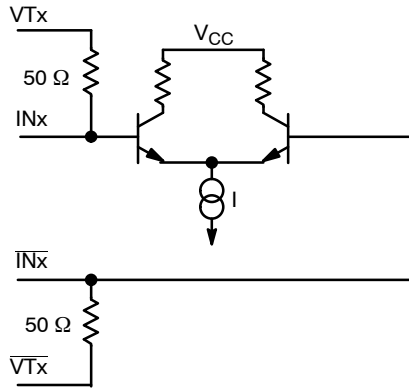

Figure 9. Input Structure

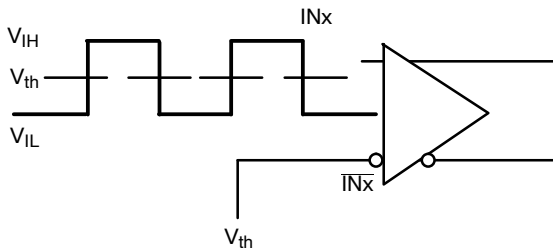

Figure 10. Differential Input Driven Single-Ended

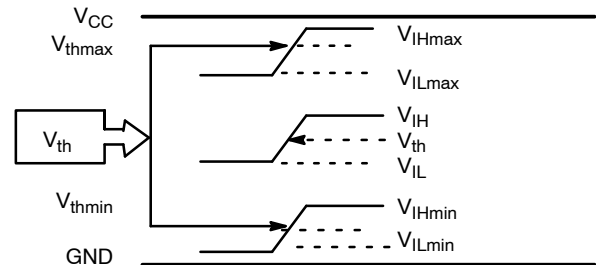

Figure 11.  $V_{th}$  Diagram

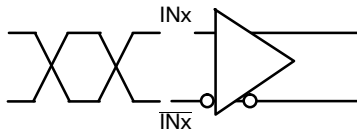

Figure 12. Differential Inputs Driven Differentially

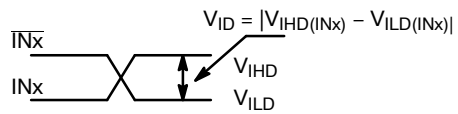

Figure 13. Differential Inputs Driven Differentially

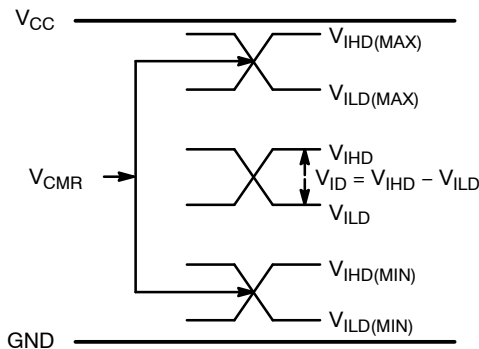

Figure 14.  $V_{CMR}$  Diagram

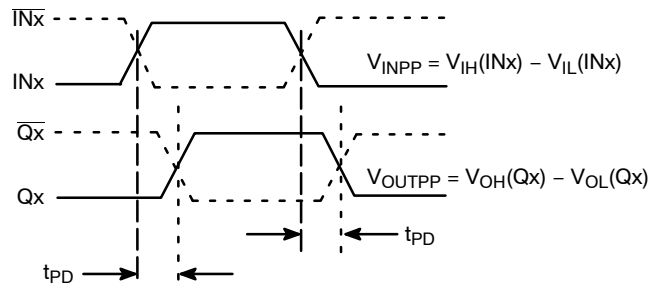

Figure 15. AC Reference Measurement

# NB6L295

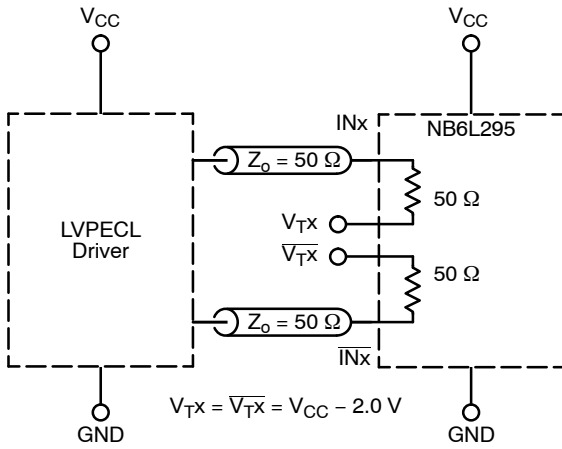

Figure 16. LVPECL Interface

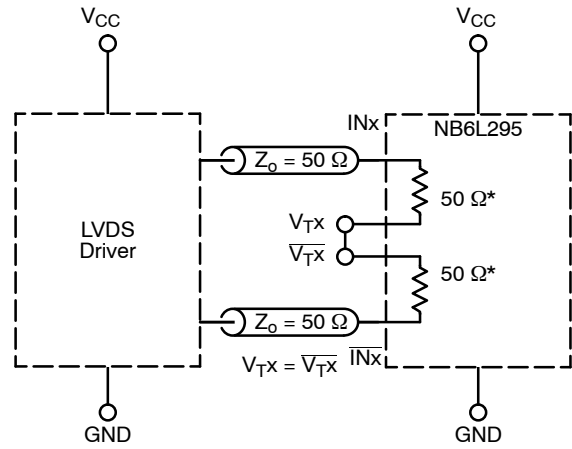

Figure 17. LVDS Interface

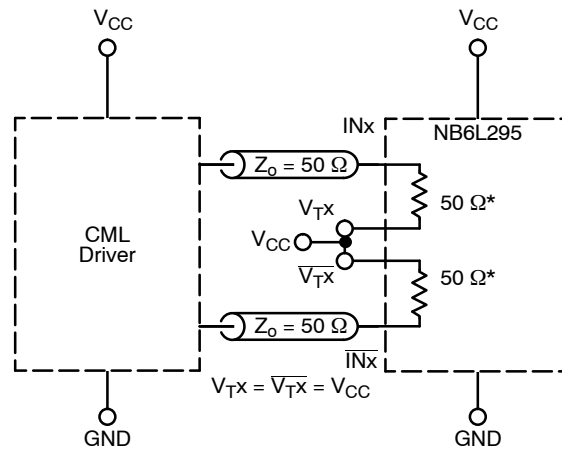

Figure 18. CML Interface, Standard 50  $\Omega$  Load

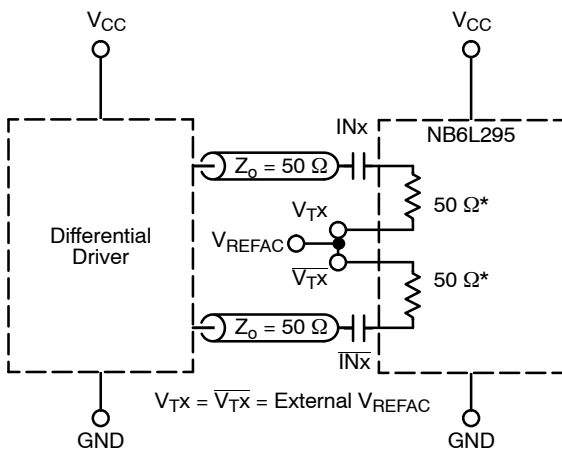

Figure 19. Capacitor-Coupled Differential Interface ( $V_{TX}/\overline{V_{TX}}$  Connected to  $V_{REFAC}$ ;  $V_{REFAC}$  Bypassed to Ground with 0.1  $\mu F$  Capacitor)

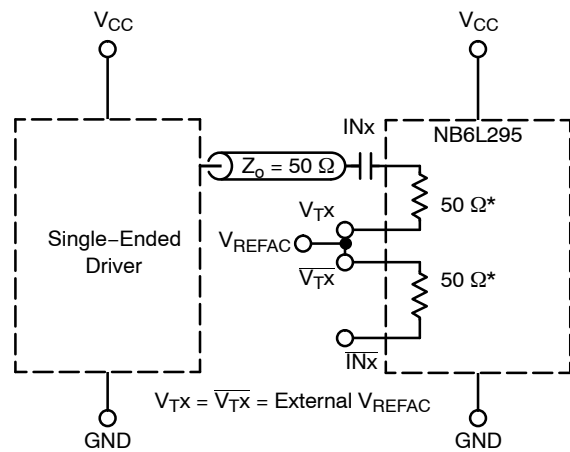
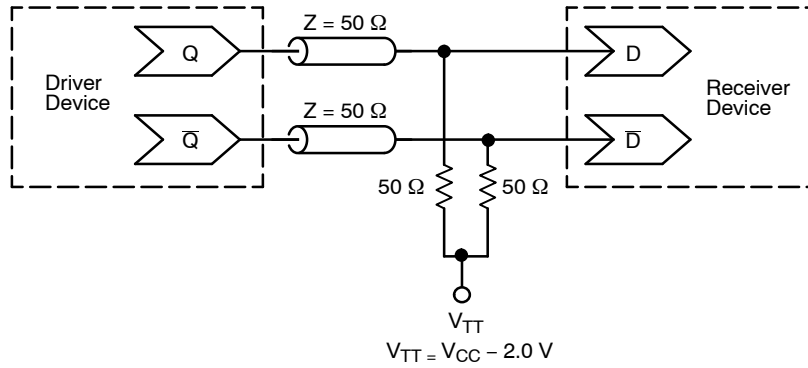
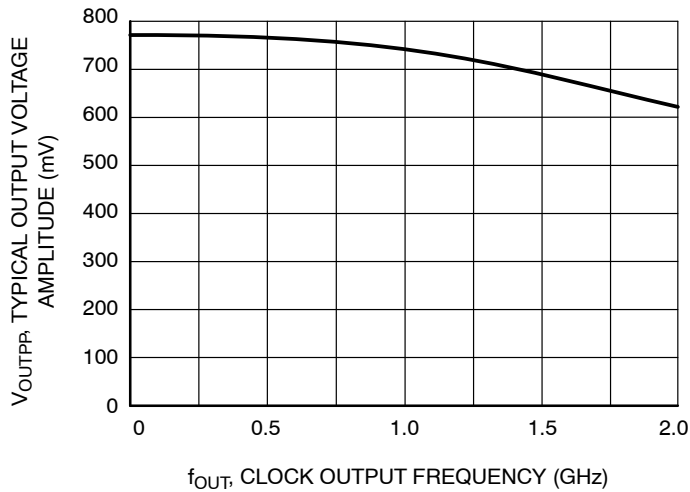

Figure 20. Capacitor-Coupled Single-Ended Interface ( $V_{TX}/\overline{V_{TX}}$  Connected to External  $V_{REFAC}$ ;  $V_{REFAC}$  Bypassed to Ground with 0.1  $\mu F$  Capacitor)

## NB6L295



**Figure 21. Typical Termination for Output Driver and Device Evaluation (See Application Note AND8020/D – Termination of ECL Logic Devices.)**



**Figure 22. Output Voltage Amplitude ( $V_{OUTPP}$ ) vs. Output Frequency at Ambient Temperature (Typical)**

### ORDERING INFORMATION

Device	Package	Shipping <sup>†</sup>
NB6L295MNG	QFN-24 (Pb-free)	92 Units / Rail
NB6L295MNTXG	QFN-24 (Pb-free)	3000 / Tape & Reel

<sup>†</sup>For information on tape and reel specifications, including part orientation and tape sizes, please refer to our Tape and Reel Packaging Specifications Brochure, BRD8011/D.

# MECHANICAL CASE OUTLINE

## PACKAGE DIMENSIONS

ON Semiconductor®



1 24

SCALE 2:1

QFN24, 4x4, 0.5P  
CASE 485L  
ISSUE B

DATE 05 JUN 2012

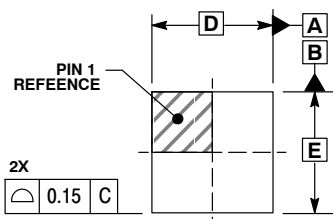

TOP VIEW

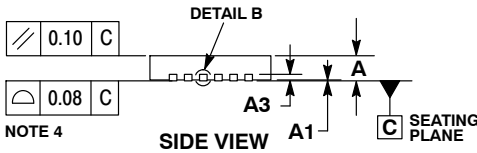

SIDE VIEW

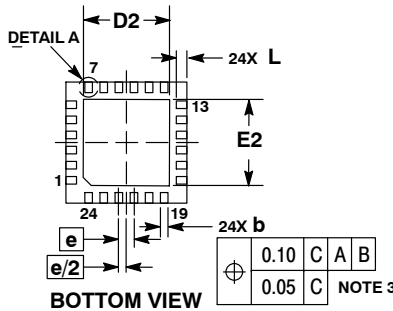

BOTTOM VIEW

### RECOMMENDED SOLDERING FOOTPRINT

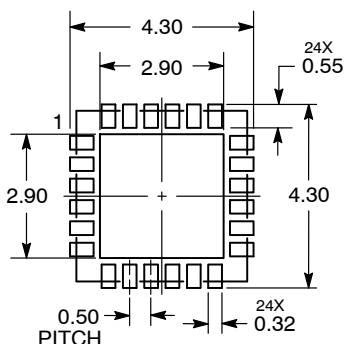

DIMENSIONS: MILLIMETERS

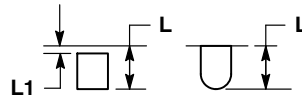

DETAIL A  
ALTERNATE  
CONSTRUCTIONS

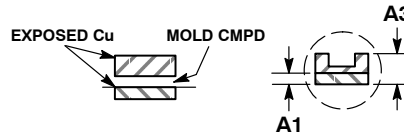

DETAIL B  
ALTERNATE TERMINAL  
CONSTRUCTIONS

#### NOTES:

- DIMENSIONING AND TOLERANCING PER ASME Y14.5M, 1994.
- CONTROLLING DIMENSION: MILLIMETERS.
- DIMENSION b APPLIES TO PLATED TERMINAL AND IS MEASURED BETWEEN 0.25 AND 0.30 MM FROM THE TERMINAL TIP.
- COPLANARITY APPLIES TO THE EXPOSED PAD AS WELL AS THE TERMINALS.

DIM	MILLIMETERS	
	MIN	MAX
A	0.80	1.00
A1	0.00	0.05
A3	0.20	REF
b	0.20	0.30
D	4.00	BSC
D2	2.70	2.90
E	4.00	BSC
E2	2.70	2.90
e	0.50	BSC
L	0.30	0.50
L1	0.05	0.15

### GENERIC MARKING DIAGRAM\*

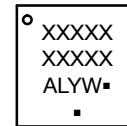

- XXXXX = Specific Device Code  
A = Assembly Location  
L = Wafer Lot  
Y = Year  
W = Work Week  
▪ = Pb-Free Package

(Note: Microdot may be in either location)

\*This information is generic. Please refer to device data sheet for actual part marking. Pb-Free indicator, "G" or microdot "▪", may or may not be present.

DOCUMENT NUMBER:	98AON11783D	Electronic versions are uncontrolled except when accessed directly from the Document Repository. Printed versions are uncontrolled except when stamped "CONTROLLED COPY" in red.
DESCRIPTION:	QFN24, 4X4, 0.5P	PAGE 1 OF 1

ON Semiconductor and ON are trademarks of Semiconductor Components Industries, LLC dba ON Semiconductor or its subsidiaries in the United States and/or other countries. ON Semiconductor reserves the right to make changes without further notice to any products herein. ON Semiconductor makes no warranty, representation or guarantee regarding the suitability of its products for any particular purpose, nor does ON Semiconductor assume any liability arising out of the application or use of any product or circuit, and specifically disclaims any and all liability, including without limitation special, consequential or incidental damages. ON Semiconductor does not convey any license under its patent rights nor the rights of others.

**onsemi**, **Onsemi**, and other names, marks, and brands are registered and/or common law trademarks of Semiconductor Components Industries, LLC dba "**onsemi**" or its affiliates and/or subsidiaries in the United States and/or other countries. **onsemi** owns the rights to a number of patents, trademarks, copyrights, trade secrets, and other intellectual property. A listing of **onsemi**'s product/patent coverage may be accessed at [www.onsemi.com/site/pdf/Patent-Marking.pdf](http://www.onsemi.com/site/pdf/Patent-Marking.pdf). **onsemi** reserves the right to make changes at any time to any products or information herein, without notice. The information herein is provided "as-is" and **onsemi** makes no warranty, representation or guarantee regarding the accuracy of the information, product features, availability, functionality, or suitability of its products for any particular purpose, nor does **onsemi** assume any liability arising out of the application or use of any product or circuit, and specifically disclaims any and all liability, including without limitation special, consequential or incidental damages. Buyer is responsible for its products and applications using **onsemi** products, including compliance with all laws, regulations and safety requirements or standards, regardless of any support or applications information provided by **onsemi**. "Typical" parameters which may be provided in **onsemi** data sheets and/or specifications can and do vary in different applications and actual performance may vary over time. All operating parameters, including "Typicals" must be validated for each customer application by customer's technical experts. **onsemi** does not convey any license under any of its intellectual property rights nor the rights of others. **onsemi** products are not designed, intended, or authorized for use as a critical component in life support systems or any FDA Class 3 medical devices or medical devices with a same or similar classification in a foreign jurisdiction or any devices intended for implantation in the human body. Should Buyer purchase or use **onsemi** products for any such unintended or unauthorized application, Buyer shall indemnify and hold **onsemi** and its officers, employees, subsidiaries, affiliates, and distributors harmless against all claims, costs, damages, and expenses, and reasonable attorney fees arising out of, directly or indirectly, any claim of personal injury or death associated with such unintended or unauthorized use, even if such claim alleges that **onsemi** was negligent regarding the design or manufacture of the part. **onsemi** is an Equal Opportunity/Affirmative Action Employer. This literature is subject to all applicable copyright laws and is not for resale in any manner.

## PUBLICATION ORDERING INFORMATION

### LITERATURE FULFILLMENT:

Email Requests to: [orderlit@onsemi.com](mailto:orderlit@onsemi.com)

**onsemi Website:** [www.onsemi.com](http://www.onsemi.com)

### TECHNICAL SUPPORT

**North American Technical Support:**

Voice Mail: 1 800-282-9855 Toll Free USA/Canada

Phone: 011 421 33 790 2910

**Europe, Middle East and Africa Technical Support:**

Phone: 00421 33 790 2910

For additional information, please contact your local Sales Representative