



LMTM78_0.5 series

Wide input, non-isolated & regulated, single output

Switching Regulator

- ⊕ Efficiency up to 92%
- ⊕ Short circuit protection (SCP)
- ⊕ Ultra-small, ultra-thin DFN package (9.00 x 7.00 x 3.10mm)
- ⊕ Operating temperature range: -40°C to +105°C
- ⊕ No-load input current as low as 0.1mA
- ⊕ Meets AEC -Q100
- ⊕ EN62368 approved

The LMTM78_0.5 series are high efficiency switching regulators. The converters feature high efficiency, low loss and short-circuit protection in a compact DFN package.

These products are widely used in applications such as industrial control, instrumentation and electric power.



Common specifications	
Cooling:	Free air convection
Short circuit protection mode:	Hiccup mode
Short circuit protection:	Continuous, automatic recovery
Operating temperature range:	-40°C ~ +105°C
Storage temperature range:	-55°C ~ +125°C
Lead temperature:	300°C MAX, 1.5mm from case for 10 sec
Operating case temperature:	100°C MAX
Reflow Soldering Temperature:	Peak temp. ≤ 245°C, maximum duration time ≤ 60s at 217°C. For actual application, please refer to IPC/JEDEC J-STD-020D.1
Storage humidity range:	< 95%
Case material:	Plastic [UL94-V0]
MTBF (MIL-HDBK-217F, +25°C):	> 9152 Khours
Weight:	0.58g
Dimensions:	9.00 x 7.00 x 3.10mm

Output specifications						
Item	Test conditions	Min	Typ	Max	Units	
Voltage accuracy	Input voltage range at full load			±2	±4	%
	• 3.3VDC • Others			±2	±3	%
Line regulation	Input voltage range at full load		±0.2			%
Load regulation	Nominal input, 10% to 100% load		±0.4			%
Ripple + Noise*	20MHz bandwidth		20	45		mVp-p
Temperature coefficient	- 40°C to + 105°C ambient		±0.02			%/°C
Transient response deviation	Nominal input voltage, 25% load step change		50	120		mV
Transient recovery time	Nominal input voltage, 25% load step change		0.2	0.8		ms
Vadj	input voltage range		±10			%Vo
Switching frequency	Full load, nominal input voltage		2.0			MHz

Input specifications						
Item	Test conditions	Min	Typ	Max	Units	
No load input current			0.1			mA
Reverse polarity input	Avoid/not protected input					
Input filter	Capacitor					
Remote ON/OFF*	• Module switch on		Ctrl pin open or pulled high (TTL 2.5~5VDC)			
	• Module switch off		Ctrl pin pulled low to GND (-Vo) (0~0.6VDC)			
	• Input current when switched off			240		μA

* The positive output ctrl pin voltage is referenced to input GND; Negative output ctrl pin voltage is referenced to -Vo.

* Ripple and noise tested with "parallel cable" method.

EMC specifications						
EMI	CE	CISPR32/EN55032	CLASS B	(see EMC recommended circuit, ②)		
EMI	RE	CISPR32/EN55032	CLASS B	(see EMC recommended circuit, ②)		
EMS	ESD*	IEC/EN61000-4-2	Contact ±6KV			perf. Criteria B
EMS	RS	IEC/EN61000-4-3	10V/m			perf. Criteria A
EMS	EFT	IEC/EN61000-4-4	±1KV			perf. Criteria B
EMS	Surge	IEC/EN61000-4-5	±1KV			perf. Criteria B
EMS	CS	IEC/EN61000-4-6	3 Vr.m.s			perf. Criteria A

* The static level of the Ctrl & Trim pin is ±2KV when they are not connected to external devices; It is suggested to connect an external capacitor (105K/50V) from Ctrl to GND/-Vo to meet ESD (±6KV) of the Ctrl pin, and to connect a varistor (22V/30A) from Trim to GND/-Vo to meet ESD (±6KV) of the Trim pin.

Example:

LMTM78_05-0.5

LM = Series; T = SMT case; M = Micro size; 05 = 5Vout; 0.5 = 0.5A

Note:

- All specifications measured at Ta = 25°C, humidity <75%, nominal input voltage and rated output load unless otherwise specified.
- In this datasheet, all the test methods of indications are based on corporate standards.

LMTM78_0.5 series

Wide input, non-isolated & regulated, single output

Product Selection Guide

Part Number	Input Voltage [VDC]		Output Voltage [VDC]	Output Current [mA, Max]	Capacitive load [μ F, max]	Efficiency [Vin. min/nom./max]
	Nominal	Range				
LMTM78_03-0.5	24	4.5-36	3.3	500	680	89/79/71
	12	7-32	-3.3	-300	470	80/82/71
LMTM78_05-0.5	24	6.5-36	5	500	680	91/83/78
	12	7-31	-5	-300	470	78/78/71
LMTM78_6.5-0.5	24	8-36	6.5	500	680	91/85/81
	12	7-28	-6.5	-250	470	80/79/73
LMTM78_09-0.5	24	12-36	9	500	680	92/90/86
	12	8-27	-9	-200	470	82/82/77
LMTM78_12-0.5	24	15-36	12	500	680	92/91/86
	12	8-24	-12	-150	470	81/83/79
LMTM78_15-0.5	24	18-36	15	500	680	91/91/87
	12	8-21	-15	-150	470	80/81/84

Note: For input voltage higher than 30VDC, a 22 μ F/50V input capacitor is required.

Typical characteristics

3.3V/5V/6.5V output

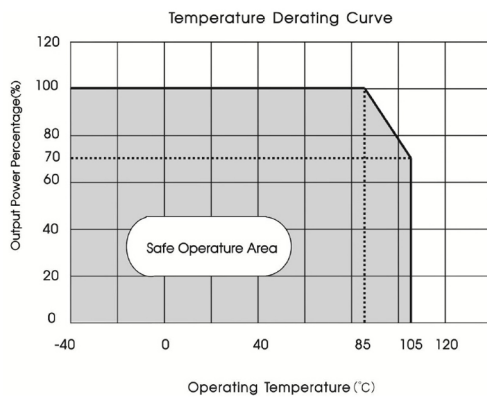

9/12/15V output

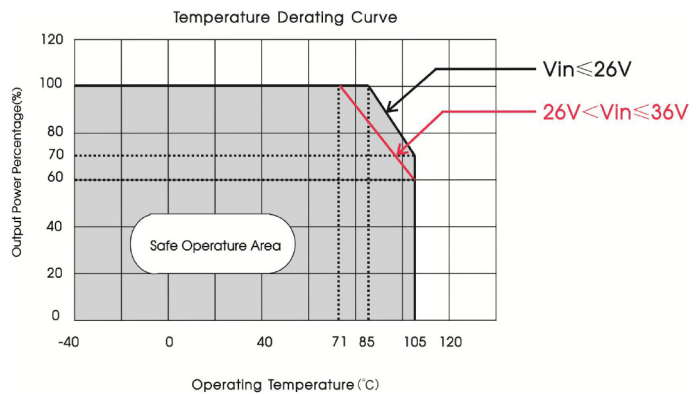

Efficiency

Efficiency Vs Input Voltage (Full Load)

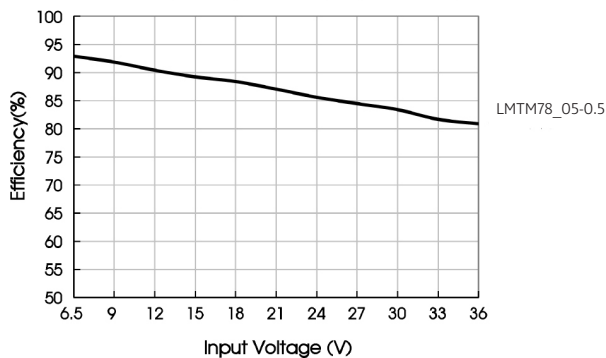

Efficiency Vs Output Load (Vin=24V)

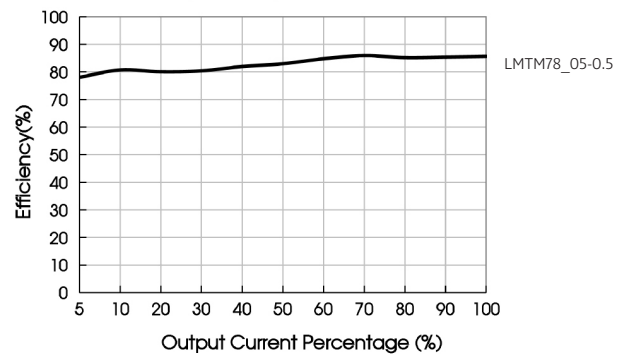

LMTM78_0.5 series

Wide input, non-isolated & regulated, single output

Typical application circuit

1. Typical application

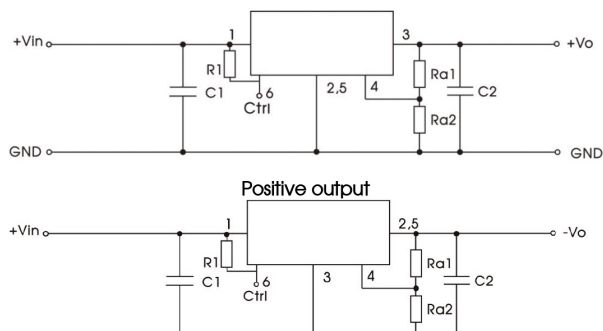

Part number	C1 (ceramic capacitor)	C2 (ceramic capacitor)	R1
LMTM78_03-0.5	10 μ F/50V	22 μ F/10V	100k Ω
LMTM78_05-0.5	10 μ F/50V	22 μ F/10V	
LMTM78_6.5-0.5	10 μ F/50V	22 μ F/16V	
LMTM78_09-0.5	10 μ F/50V	22 μ F/16V	
LMTM78_12-0.5	10 μ F/50V	22 μ F/25V	
LMTM78_15-0.5	10 μ F/50V	22 μ F/25V	

Table 1

Note:

1. The required C1 and C2 capacitors must be connected as close as possible to the terminals of the module;
2. Refer to Table 1 for C1 and C2 capacitor values. For certain applications, increased values and/or tantalum or low ESR electrolytic capacitors may also be used instead;
3. Converter cannot be used for hot swap and with output in parallel;
4. 100k is recommended for R1 when CTRL function is used. If the Ctrl function is not needed, the Ctrl pin can be shorted to the VIN pin without R1.

EMC compliance circuit

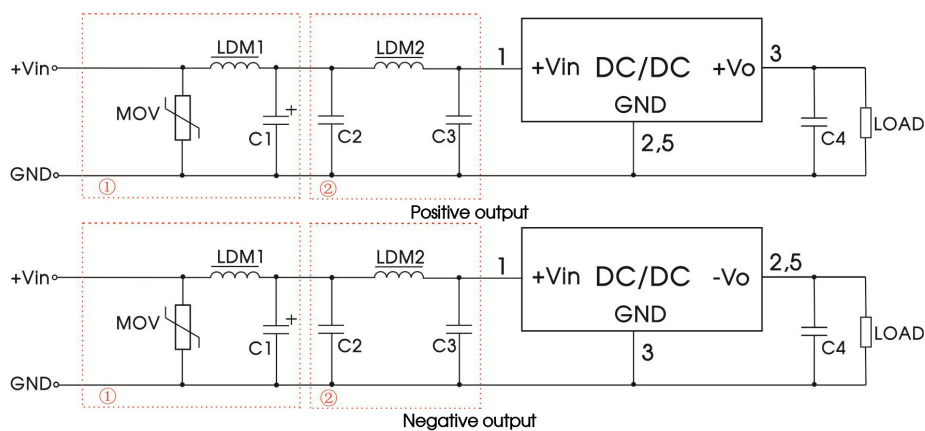

Note:

For EMC tests we use Part ① for immunity and part ② for emissions test. Selecting based on needs.

Part No.	MOV	LDM1	C1	C2	LDM2	C3	C4
LMTM78_03-0.5 (positive output)	S20K30	82 μ H	680 μ F /50V	10 μ F/50V	10 μ H	0.47 μ F/50V	22 μ F/10V
LMTM78_03-0.5 (negative output)					22 μ H	/	22 μ F/10V
LMTM78_05-0.5					10 μ H	/	22 μ F/10V
LMTM78_6.5-0.5 / LMTM78_09-0.5					10 μ H	1 μ F/50V	22 μ F/16V
LMTM78_12-0.5 / LMTM78_15-0.5					22 μ H	0.47 μ F/50V	22 μ F/16V

LMTM78_0.5 series

Wide input, non-isolated & regulated, single output

Trim Function for Output Voltage Adjustment (open if unused)

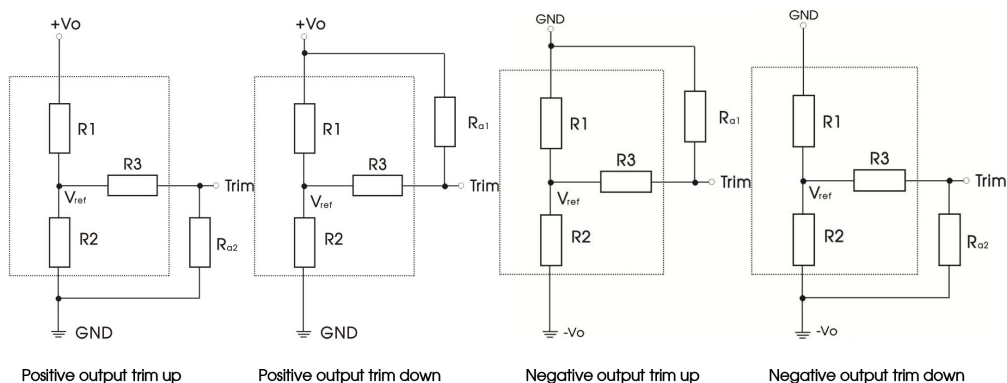

Circuit diagram of Vadj up and down (dashed line shows internal part of module)
Calculating Trim resistor values:

$$\text{Trim up : } R_{a2} = \frac{aR_3}{R_2 - a} - R_3, \quad a = R_2 / (R_3 + R_{a2}) = \frac{V_{ref} - V_1}{V_o - V_{ref}} - R_1$$

$$\text{Trim down : } R_{a1} = \frac{aR_1}{R_1 - a} - R_3, \quad a = R_1 / (R_3 + R_{a1}) = \frac{V_o - V_{ref}}{V_{ref}} - R_2$$

Vout (V)	R1 (KΩ)	R2 (KΩ)	R3 (KΩ)	Vref (V)
3.3	47	15	82	0.8
5	36	6.875	36	0.8
6.5	47	6.596	36	0.8
9	75	7.318	47	0.8
12	120	8.571	51	0.8
15	100	5.634	36	0.8

Vout nom.	±3.3VDC		±5.0VDC		±6.5VDC		±9.0VDC		±12VDC		±15VDC	
Vout adj.	Ra1	Ra2	Ra1	Ra2	Ra1	Ra2	Ra1	Ra2	Ra1	Ra2	Ra1	Ra2
2.97	221k											
3.63		34k										
4.5			236k									
5.5				20k								
5.85					329k							
7.15						22k						
8.1							562k					
9.9								19k				
10.8									948k			
13.2										29k		
13.5											811k	
16.5												17k

Temperature Rise Test PCB Layout

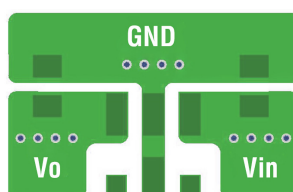

LMTM78_0.5 series

Wide input, non-isolated & regulated, single output

Mechanical dimensions

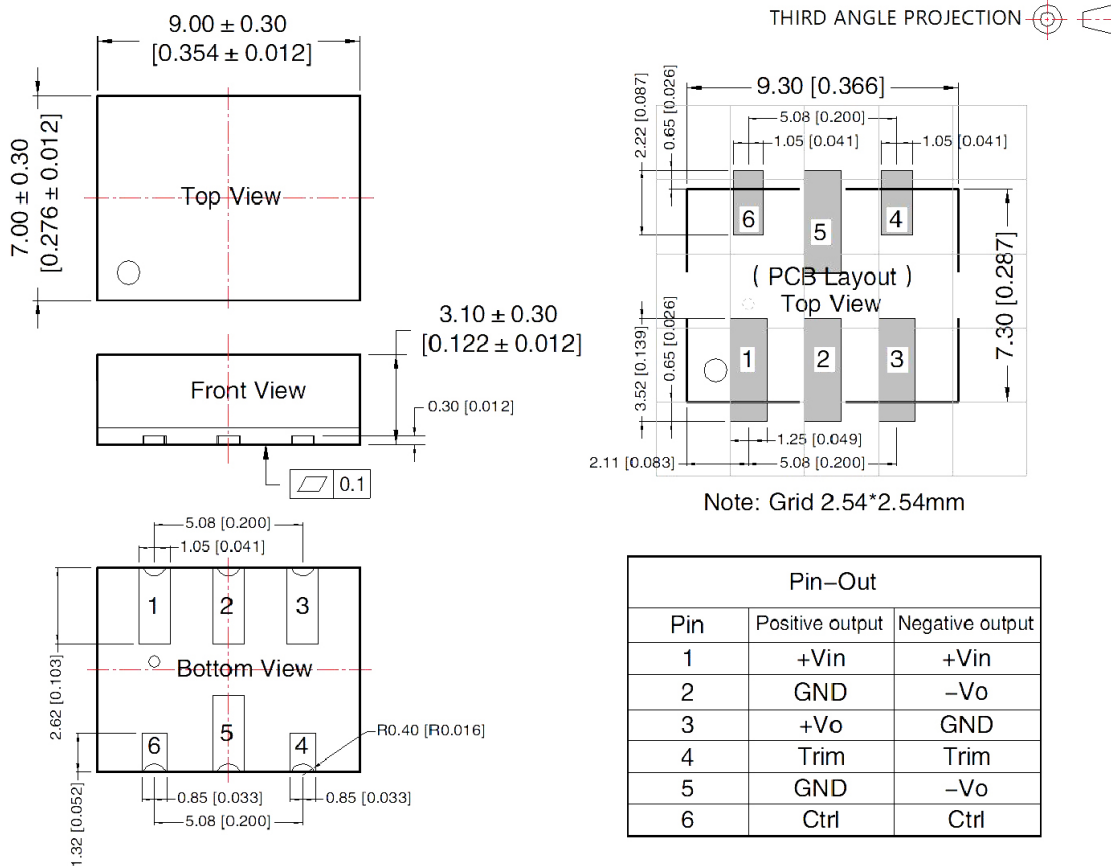

Note:
Unit: mm[inch]
General tolerances: ± 0.10[± 0.004]

Tape/Reel packaging

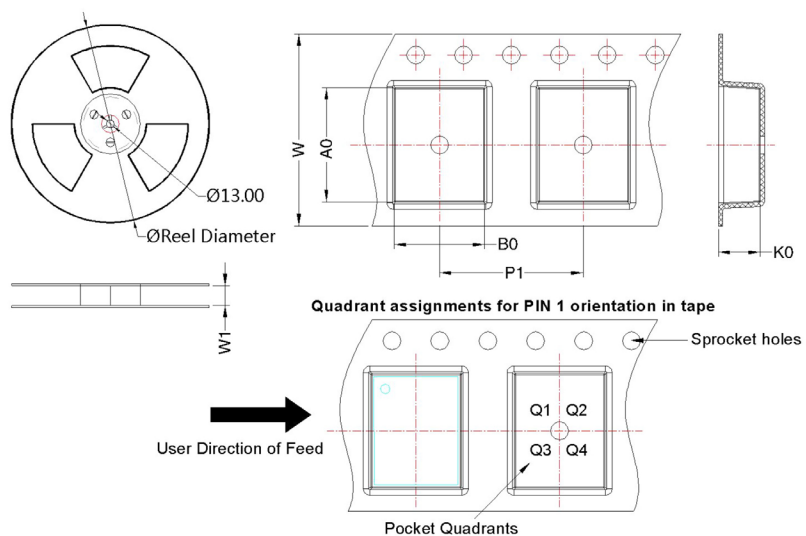

Package Type	Pin	MPQ	Reel Diameter (mm)	Reel Width W1 (mm)	A0 (mm)	B0 (mm)	K0 (mm)	P1 (mm)	W (mm)	Pin1 Quadrant
SMD	6	1200	330.0	12.4	9.56	7.56	3.5	12.0	16.0	Q1