

## General Description

The IDTVS512 is a bi-directional 5-Port 2:1 multiplexer/demultiplexer with Hi-Z outputs for both RGB and composite video switching applications. With the additional two ports, vertical and horizontal synchronous signals can be switched in addition to switching the RGB and composite signals between different components (DVDs, VCRs, PCs, etc.). The VideoSwitch can be driven from a current output RAMDAC or voltage output composite video source.

Low on-resistance, low crosstalk, low OFF isolation and wide bandwidth features make it ideal for video and other applications. The IDTVS512 offers a high-performance (600 MHz), low-cost solution to switch between video sources.

## Features

- RON is 4Ω typical
- Bidirectional switch
- Low bit-to-bit skew: 200ps
- Low crosstalk: -65dB @ 10MHz
- Near-Zero propagation delay: 250ps
- Fast switching speed: 9ns
- Channel On-Capacitance: 6pF (typical)
- 8KV ESD HBM on connector side
- Wide bandwidth (600 MHz)
- Available in QSOP package

## Applications

- Projection TV and LCD TV
- Video consumer applications
- Analog video signal routing

## Block Diagram

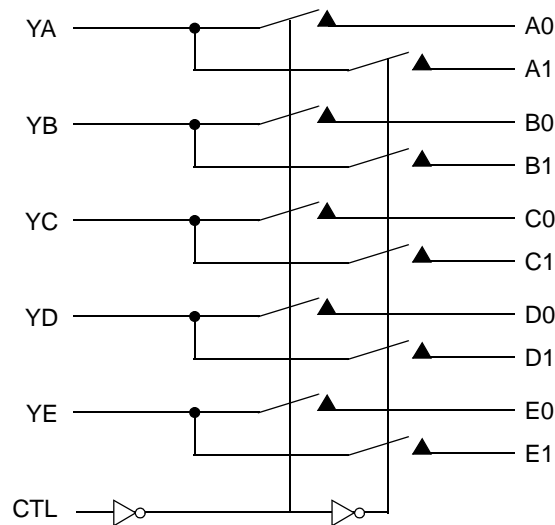

## Pin Configuration

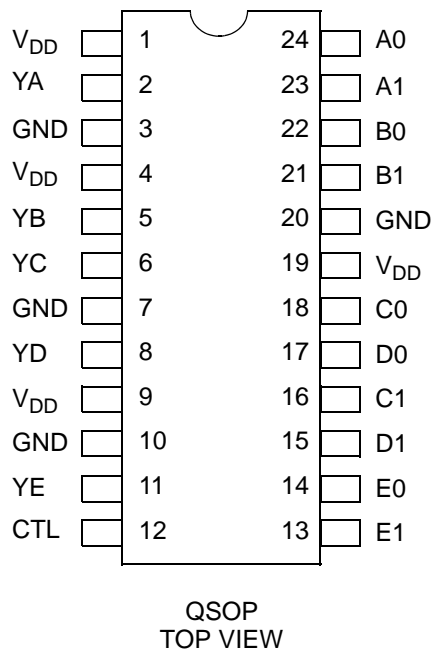

## Absolute Maximum Ratings

Symbol	Rating	Min	Max <sup>1</sup>	Unit
TSTG	Storage Temperature Range	- 65	+150	°C
	Supply Voltage to GND Potential	- 0.5	+4	V
	DC Input Voltage	- 0.5	+5.5	V
	DC Output Current	—	120	mA
	Power Dissipation	—	0.5	W

1. Stresses greater than those listed under ABSOLUTE MAXIMUM RATINGS may cause permanent damage to the device. This is a stress rating only and functional operation of the device at these or any other conditions above those indicated in the operational sections of this specification is not implied. Exposure to absolute maximum rating conditions for extended periods may affect reliability.

## Capacitance (TA = +25°C, f = 1.0MHz)

Symbol	Parameter	Conditions	Typ	Max <sup>1</sup>	Unit
C <sub>IN</sub>	Input Capacitance	V <sub>IN</sub> = 0V	2	3	pF
C <sub>OFF(IN0, IN1)</sub>	Port I Capacitance, Switch OFF	V <sub>IN</sub> = 0V	4	6	pF
C <sub>ON(Y/I)</sub>	Y/I Port Capacitance, Switch ON	V <sub>IN</sub> = 0V	6	10	pF

1. As applicable to the device type.

## Pin Description

Name	Pin #	Function
V <sub>DD</sub>	1, 4, 9, 19	Positive power supply
GND	3, 7, 10, 20	Ground
X <sub>n</sub>	2, 5, 6, 8, 11, 13, 14, 15, 16, 17, 18, 21, 22, 23, 24	Data and CLK
CTL	12	Control

## Truth Table

Function	SEL
Y <sub>n</sub> to Y <sub>0</sub>	L
Y <sub>n</sub> to X <sub>1</sub>	H

## Dynamic Electrical Characteristics Over Operating Range

Following Conditions Apply Unless Otherwise Specified:

T<sub>A</sub> = 0°C to +70°C, V<sub>CC</sub> = 3.3V ± 10%, GND = 0V..

Symbol	Parameter	Conditions	Min.	Typ.	Max.	Unit
X <sub>TALK</sub> <sup>1</sup>	Crosstalk	t = 10MHz	—	-65	—	dB
O <sub>IRR</sub> <sup>2</sup>	Off Isolation	t = 10MHz	—	-70	—	
B <sub>W</sub>	Bandwidth - 3dB	C <sub>L</sub> = 0pF	—	600	—	MHz

1. See CROSSTALK SETUP for Measurement Setup.

2. See OFF-ISOLATION SETUP for Measurement Setup.

## DC Electrical Characteristics Over Operating Range

Following Conditions Apply Unless Otherwise Specified:

T<sub>A</sub> = 0°C to +70°C, V<sub>CC</sub> = 3.3V ± 10%.

Symbol	Parameter	Conditions <sup>1</sup>	Min.	Typ. <sup>2</sup>	Max.	Unit
V <sub>IH</sub> <sup>3</sup>	Input HIGH Voltage	Guaranteed Logic HIGH level	2	—	—	V
V <sub>IL</sub>	Input LOW Voltage	Guaranteed Logic LOW level	-0.5	—	0.8	
V <sub>IK</sub>	Clamp Diode Voltage	V <sub>CC</sub> = Max., I <sub>IN</sub> = -18mA	—	-0.7	-1.2	
I <sub>IH</sub>	Input HIGH Current	V <sub>CC</sub> = Max., V <sub>IN</sub> = V <sub>CC</sub>	—	—	±5	μA
I <sub>IL</sub>	Input LOW Current	V <sub>CC</sub> = Max., V <sub>IN</sub> = GND	—	—	±5	
I <sub>OFF</sub>	Power Down Leakage Current	V <sub>CC</sub> = 0V, V <sub>A</sub> = 0V, V <sub>B</sub> ≤ 3.6	—	—	—	
R <sub>ON</sub> <sup>4</sup>	Switch On-Resistance	V <sub>CC</sub> = Min., 1.5 ≤ V <sub>IN</sub> ≤ V <sub>CC</sub> , I <sub>IN</sub> = -40mA	—	4	8	
R <sub>FLAT(ON)</sub>	On-Resistance Flatness	V <sub>CC</sub> = Min., V <sub>IN</sub> @ 1.5V and V <sub>CC</sub> , I <sub>IN</sub> = -40mA	—	1	—	Ω
ΔR <sub>ON</sub>	On-Resistance match from center ports to any other port	V <sub>CC</sub> = Min., 1.5 ≤ V <sub>IN</sub> ≤ V <sub>CC</sub> , I <sub>IN</sub> = -40mA	—	0.9	2	

1. For Max. or Min. conditions, use appropriate value specified under Electrical Characteristics for the applicable device type.

2. Typical values are at V<sub>CC</sub> = 3.3V, T<sub>A</sub> = 25°C ambient and maximum loading.

3. Measured by the voltage drop between Y and I pins at indicated current through the switch. On-Resistance is determined by the lower of the voltages on the two (Y & I) pins.

4. This parameter is determined by device characterization but is not production tested.

## Power Supply Characteristics

Symbol	Parameter	Conditions <sup>1</sup>	Min.	Typ. <sup>2</sup>	Max.	Unit
$I_{CC}$	Quiescent Power Supply Current	$V_{CC} = \text{Max.}, V_{IN} = \text{GND or } V_{CC}$	—	—	800	$\mu\text{A}$

- For Max. or Min. conditions, use appropriate value specified under Electrical Characteristics for the applicable device.
- Typical values are at  $V_{CC} = 3.3\text{V}$ ,  $T_A = 25^\circ\text{C}$  ambient and maximum loading.

## Switching Characteristics Over Operating Range

Following Conditions Apply Unless Otherwise Specified:

$T_A = 0^\circ\text{C}$  to  $+70^\circ\text{C}$ ,  $V_{CC} = 3.3\text{V} \pm 10\%$ ,  $\text{GND} = 0\text{V}$ .

Symbol	Description	Min.	Typ. <sup>1</sup>	Max.	Unit
$t_{PD}$	Propagation Delay <sup>2,3</sup>	—	0.25	—	ns
$t_{PZH}, t_{PZL}$	Line Enable Time - SEL to $Y_n$ , In	0.5	—	15	ns
$t_{PHZ}, t_{PLZ}$	Line Disable Time - SEL to $Y_n$ , In	0.5	—	9	ns
$t_{SK(O)}$	Output Skew between center port (YC to YD) to any other port(2)	—	0.1	0.2	ns
$t_{SK(P)}$	Skew between opposite transitions of the same output (tPHL- tPLH)(2)	—	0.1	0.2	ns

- For max. or min. conditions, use appropriate value specified under Electrical Characteristics for the applicable device type.
- Guaranteed by design.,
- The bus switch contributes no propagational delay other than the RC delay of the On-Resistance of the switch and the load capacitance. The time constant for the switch alone is of the order of 0.25ns for 10pF load. Since this time constant is much smaller than the rise/fall times of typical driving signals, it adds very little propagational delay to the system. Propagational delay of the bus switch when used in a system is determined by the driving circuit on the driving side of the switch and its interactions with the load on the driven side.

## Switching Waveforms

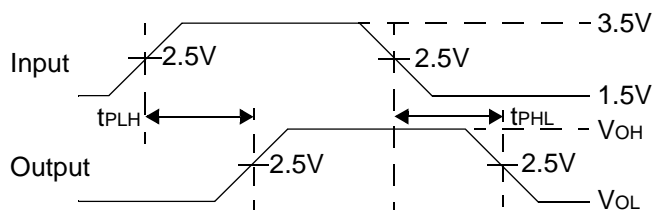

Voltage Waveforms Propagation Delay Times

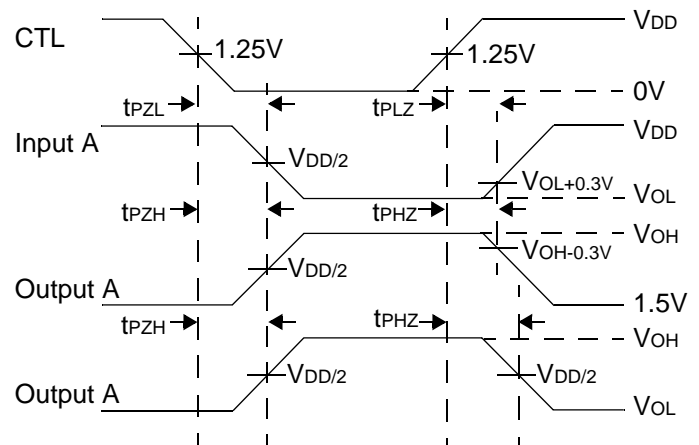

Voltage Waveforms Enable and Disable Times

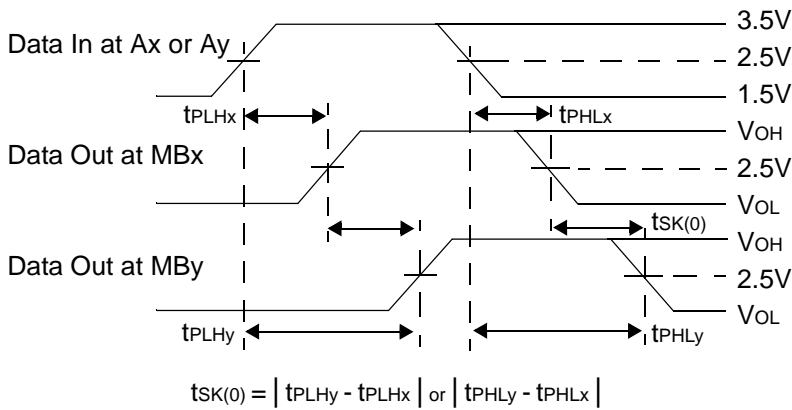

**Output Skew - tsk(o)**

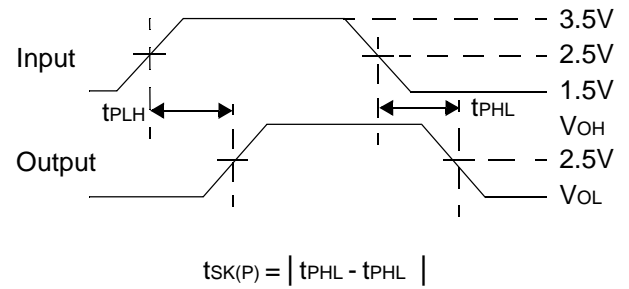

**Pulse Skew - tsk(p)**

## Applications Information

### Logic Inputs

The logic control inputs can be driven up to +3.6V regardless of the supply voltage. For example, given a +3.3V supply, the output enables or select pins may be driven low to 0V and high to 3.6V. Driving IN Rail-to-RailÆ minimizes power consumption.

### Power-supply Sequencing

Proper power-supply sequencing is advised for all CMOS devices. It is recommended to always apply V<sub>CC</sub> before applying signals to the input/output or control pins.

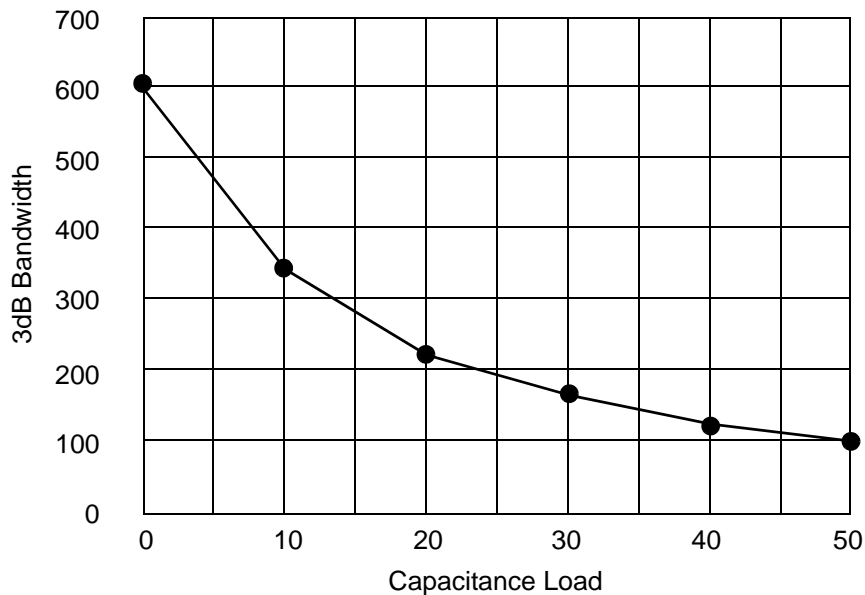

**Bandwidth vs. Capacitance**

### Test Circuit For Electrical Characteristics

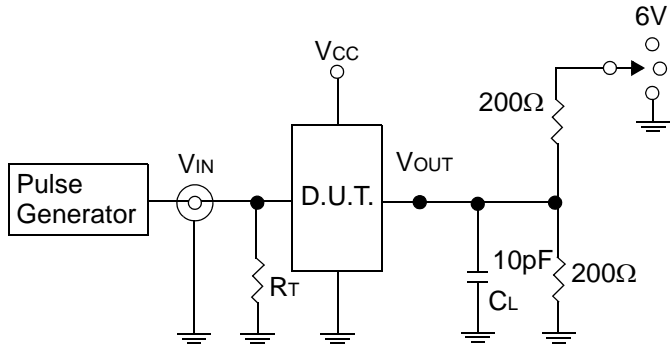

Switch Position

Test	Switch
$t_{PZH}$ , $t_{PZL}$ (output on I-side)	6V
$t_{PHZ}$ , $t_{PLZ}$ (output on I-side)	GND
Prop Delay	Open

- 1 CL = Load capacitance: includes jig and probe capacitance.
- 2 RT = Termination resistance: should be equal to  $Z_{OUT}$  of the Pulse Generator.
- 3 Waveform 1 is for an output with internal conditions such that the output is low except when disabled by the output control. Waveform 2 is for an output with internal conditions such that the output is high except when disabled by the output control.
- 4 All input impulses are supplied by generators having the following characteristics:  $PRR \leq \text{MHz}$ ,  $Z_o = 50\Omega$ ,  $t_r \leq 2.5\text{ns}$ ,  $t_f \leq 2.5\text{ns}$ .
- 5 The outputs are measured one at a time with one transition per measurement.

### Test Circuit for Dynamic Electrical Characteristics

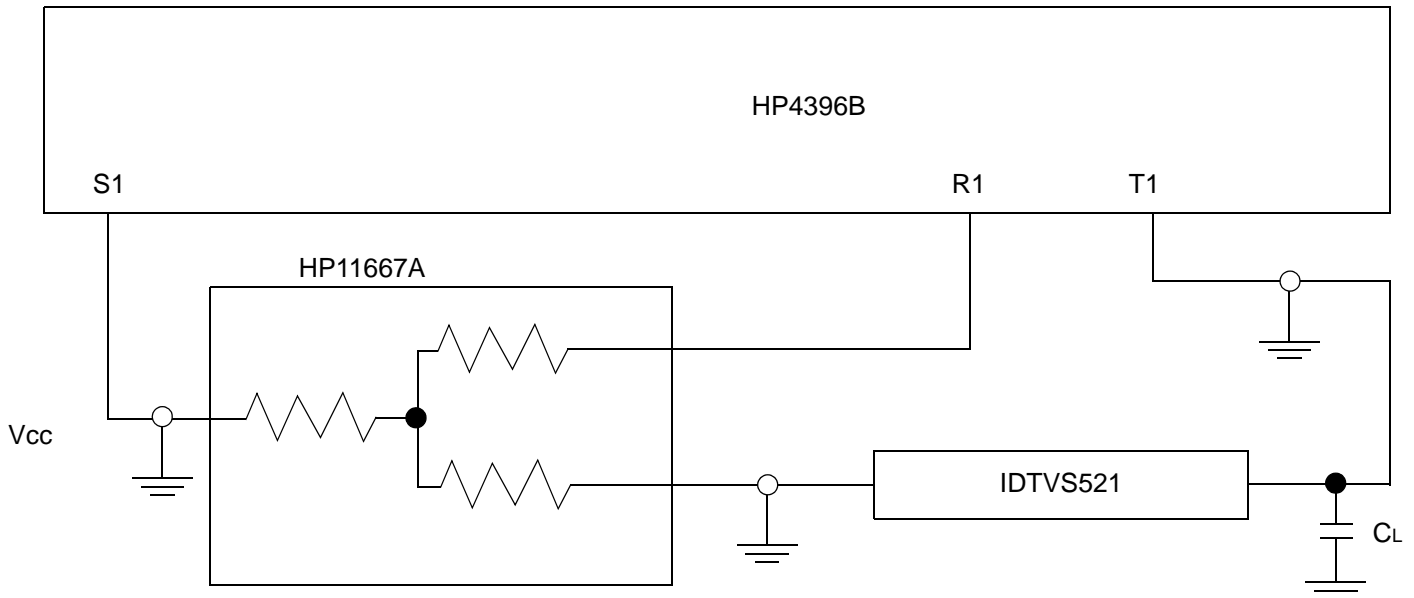

Package Dimensions - QAOP

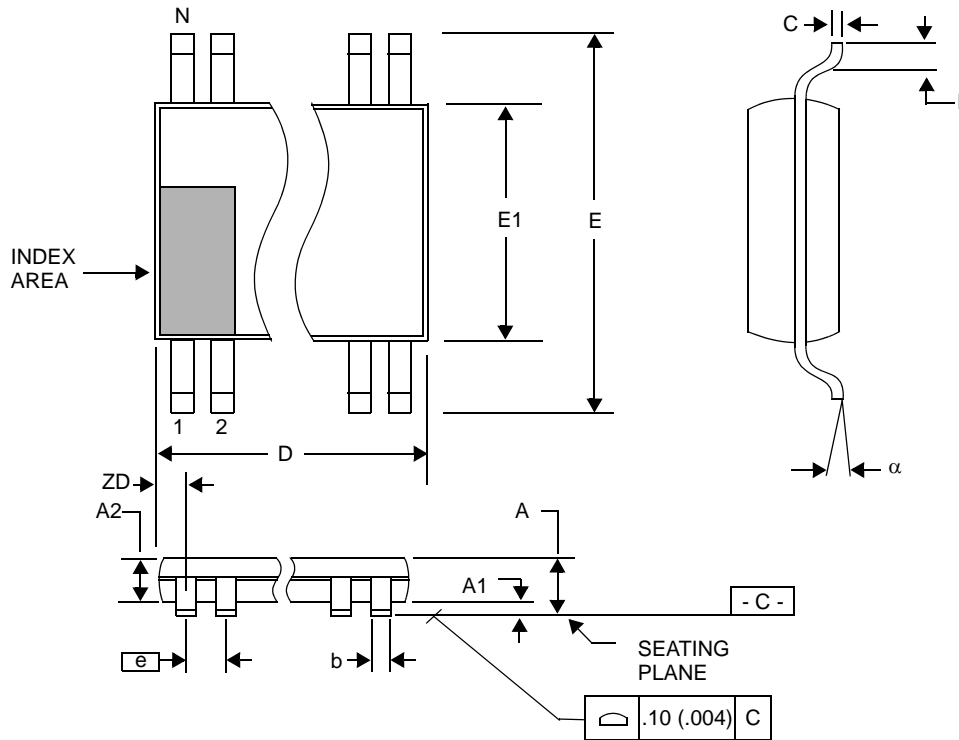

150 mil SSOP (QSOP))

Symbol	In Millimeters Common Dimensions		In Inches Common Dimensions <sup>1</sup>	
	MIN	MAX	MIN	MAX
A	1.35	1.75	.053	.069
A1	0.10	0.25	.004	.010
A2	—	1.50	—	.059
b	0.20	0.30	.008	.012
c	0.18	0.25	.007	.010
D	8.55	8.75	.337	.344
E	5.80	6.20	.228	.244
E1	3.80	4.00	.150	.157
e	.635 BASIC		0.025 BASIC	
L	0.40	1.27	.016	.050
N	24		24	
alpha	0°	8°	0°	8°
ZD	0.84 REF		.394 REF	

1. For reference only. Controlling dimensions are in inches.

## Ordering Information

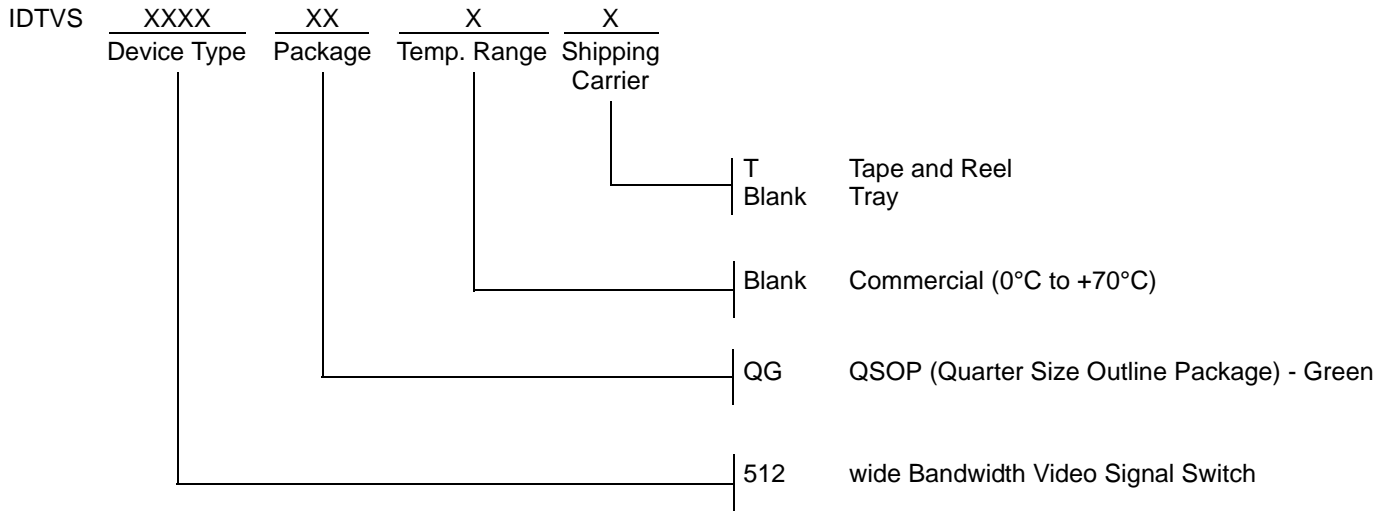



## IMPORTANT NOTICE AND DISCLAIMER

RENESAS ELECTRONICS CORPORATION AND ITS SUBSIDIARIES (“RENESAS”) PROVIDES TECHNICAL SPECIFICATIONS AND RELIABILITY DATA (INCLUDING DATASHEETS), DESIGN RESOURCES (INCLUDING REFERENCE DESIGNS), APPLICATION OR OTHER DESIGN ADVICE, WEB TOOLS, SAFETY INFORMATION, AND OTHER RESOURCES “AS IS” AND WITH ALL FAULTS, AND DISCLAIMS ALL WARRANTIES, EXPRESS OR IMPLIED, INCLUDING, WITHOUT LIMITATION, ANY IMPLIED WARRANTIES OF MERCHANTABILITY, FITNESS FOR A PARTICULAR PURPOSE, OR NON-INFRINGEMENT OF THIRD PARTY INTELLECTUAL PROPERTY RIGHTS.

These resources are intended for developers skilled in the art designing with Renesas products. You are solely responsible for (1) selecting the appropriate products for your application, (2) designing, validating, and testing your application, and (3) ensuring your application meets applicable standards, and any other safety, security, or other requirements. These resources are subject to change without notice. Renesas grants you permission to use these resources only for development of an application that uses Renesas products. Other reproduction or use of these resources is strictly prohibited. No license is granted to any other Renesas intellectual property or to any third party intellectual property. Renesas disclaims responsibility for, and you will fully indemnify Renesas and its representatives against, any claims, damages, costs, losses, or liabilities arising out of your use of these resources. Renesas' products are provided only subject to Renesas' Terms and Conditions of Sale or other applicable terms agreed to in writing. No use of any Renesas resources expands or otherwise alters any applicable warranties or warranty disclaimers for these products.

(Rev.1.0 Mar 2020)

### Corporate Headquarters

TOYOSU FORESIA, 3-2-24 Toyosu,  
Koto-ku, Tokyo 135-0061, Japan  
[www.renesas.com](http://www.renesas.com)

### Contact Information

For further information on a product, technology, the most up-to-date version of a document, or your nearest sales office, please visit:  
[www.renesas.com/contact/](http://www.renesas.com/contact/)

### Trademarks

Renesas and the Renesas logo are trademarks of Renesas Electronics Corporation. All trademarks and registered trademarks are the property of their respective owners.