

## ECM3532 AI Sensor Board: Ultra Low Power Sensor Board for Artificial Intelligence at the Edge

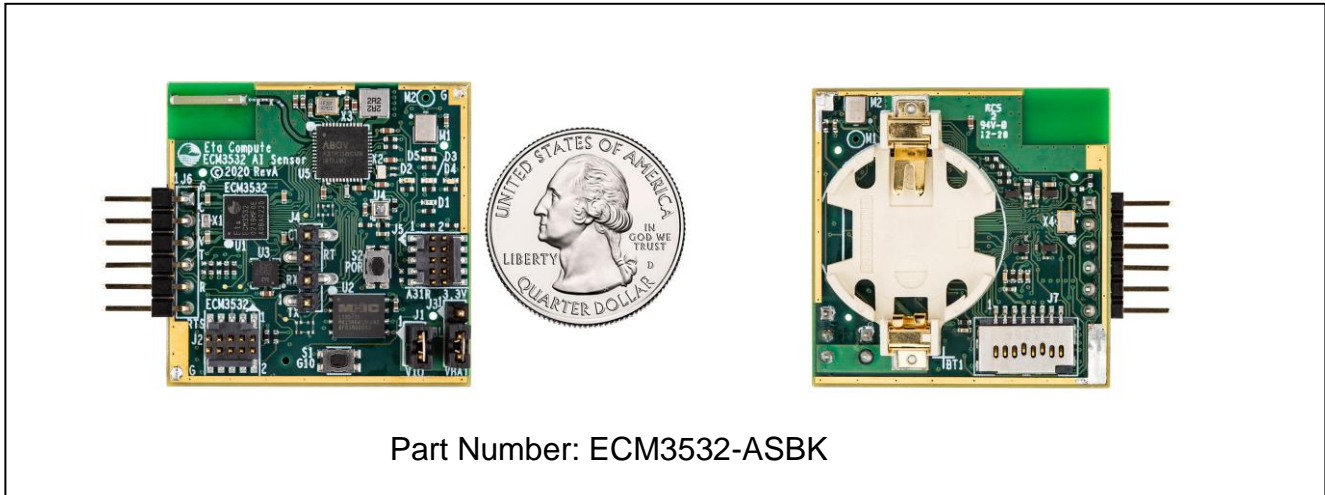

### Features:

- **1.4 x1.4-inch board with sensors**
  - 2 x PDM MEMS Microphones: TDK-Invensense ICS-41350
  - 1 x Pressure/Temperature sensor: BOSCH BMP388
  - 1 x 6-axis MEMS Accel/Gyro: TDK-Invensense ICM-20602
- **Battery cradle for CR2032 battery**
- **Bluetooth Low Energy on board**
  - BLE v4.2: ABOV A31R118 and antenna
- **Extension for other types of RF through Micro SD card slot**
- **6 pin UART and power port**
- **64Mbit serial Flash for datalogging**
- **5 LEDs and push button.**
- **ECM3532 Neural Sensor Processor**
  - Hybrid multi-core with Cortex-M and DSP with operation up to 100MHz with self-timed continuous voltage and frequency scaling technology (CVFS)
  - Lowest energy for inference for machine learning algorithms: less than 1 mW
  - 512kB embedded Flash
  - 256kB + 96KB SRAM
  - Always-on block and low power mode down to sub 1uA
  - Numerous peripherals: UART, SPI, I2C, I2S, PDM, ADC, Timers
  - 5x5mm BGA Package

**Description:**

The ECM3532 AI Sensor board is an ultra-low power AI platform with sensors that can run many algorithms: sound classification, keyword spotting, activity classification, context awareness, defect detection and others.

It showcases the capabilities of the ECM3532 Neural Sensor Processor built with Eta Compute’s unique self-timed continuous voltage and frequency scaling technology (CVFS).

See below a high-level block diagram:

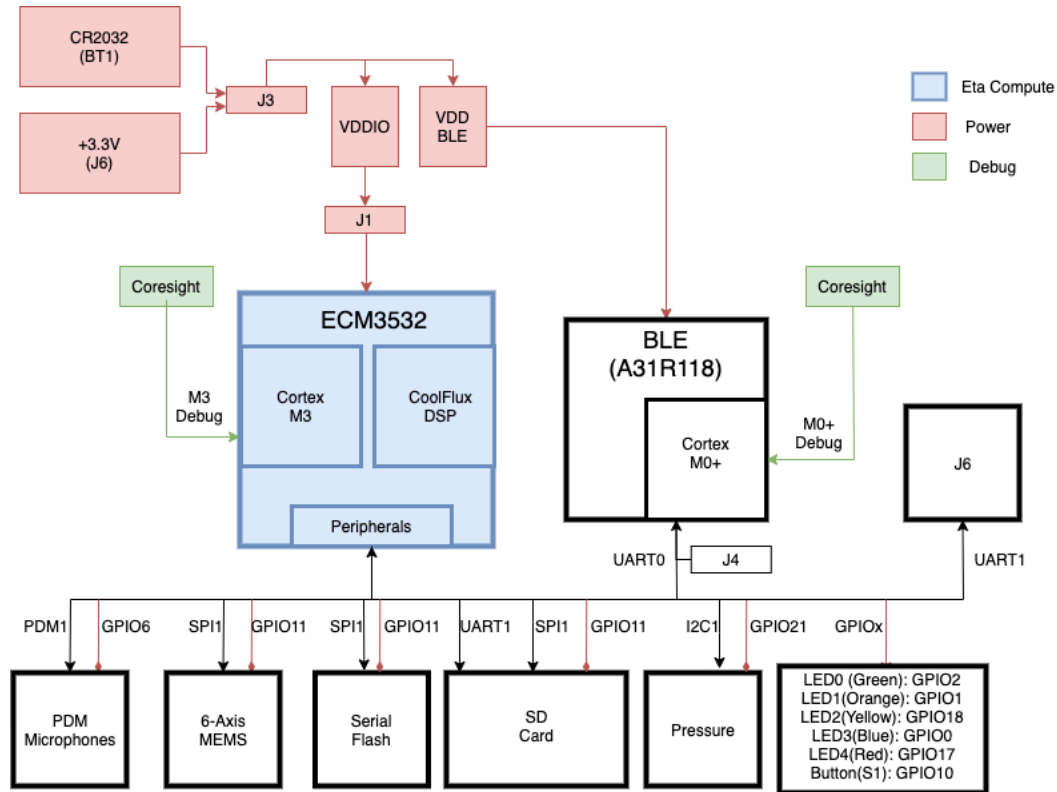

Users can best experience the versatility of the ECM3532 AI Sensor board in minutes by using Edge Impulse’s TinyML development pipeline and the 6 pin UART port.

For advanced users, the board has serial wire debug (SWD) CoreSight connectors for both the ECM3532 and the A31R118 for debugging. A separate JLink or Ulink probe is required.

**Website:**

<http://www.etacompute.com/>

**General Information:**

[info@etacompute.com](mailto:info@etacompute.com)