

General Description

BDE-BLEM201P is a Bluetooth 5.0 single-mode compliant Bluetooth low energy module targeted at low power sensors and PC/Phone accessories.



BDE-BLEM201P highly integrates Bluetooth Low Energy radio, stack, profiles and applications in a SoC, without the need of using an external MCU. The module also offers flexible hardware interfaces for the sensor application. It supports BDE-SPP (Serial port profile provided by BDE). Integrated with BDE-SPP, customer can simply look at it as a serial port and transfer data through UART to BLE.

It enables ultra low power connectivity and data transfer for the applications that are sensitive to power consumption, size and cost.

Key Features

- Bluetooth 5.0 single-mode compliant
- Support master and slave modes, 3+ simultaneous connections in master mode
- Integrated Bluetooth Low Energy stack, no external MCU needed
- RF performance
 - TX power: -23dBm to 0dBm
 - RX sensitivity: up to -94dBm @ 1Mbps
- Communication range: 30 meters (LOS)
- Ultra low power 8051 microcontroller core
 - 8K RAM with retention
 - 256K in-system-programming flash
 - 23 GPIOs (21 x 4mA, 2 x 20mA)
 - 12-bit ADC with eight channels and configurable resolution
- I2C, USART, SPI
- PWM
- Ultra low power consumption
 - 0.5uA @ Shutdown (External Interrupts)
 - 18.2mA @ TX (0dBm)
 - 17.9mA @ RX
- Antenna: PCB antenna
- Size
 - 16.55mm x10.88mm x 2.2mm (With Shielding)
- BDE-SPP supported
- Certification
 - FCC ID: 2ABRUBDLEM201P
 - CE-RED

Applications

- Medical devices
- Sports and fitness equipment
- Home electronics
- Mobile and PC accessories
- Industry automation

Contents

General Description	1
Key Features.....	1
Applications	1
Contents.....	2
1. References	3
2. Block Diagram.....	4
3. Terminal Configuration and Functions.....	5
3.1 Pin Diagram.....	5
3.2 Pin Attributes and Pin Multiplexing	5
4. Specifications.....	7
4.1 Absolute Maximum Ratings	7
4.2 Recommended Operating Conditions.....	7
5. Reference Design	8
5.1 Design Recommendations	8
	9
6. Typical Solder Reflow Profile	10
7. Mechanical Specifications	11
7.1 Dimensions	11
7.2 PCB Footprint	11
7.3 Marking.....	12
8. Packaging Information	13
9. Ordering Information.....	14
10. Revision History	14

1. References

[1] CC2541 resources: <https://www.ti.com/product/CC2541>

2. Block Diagram

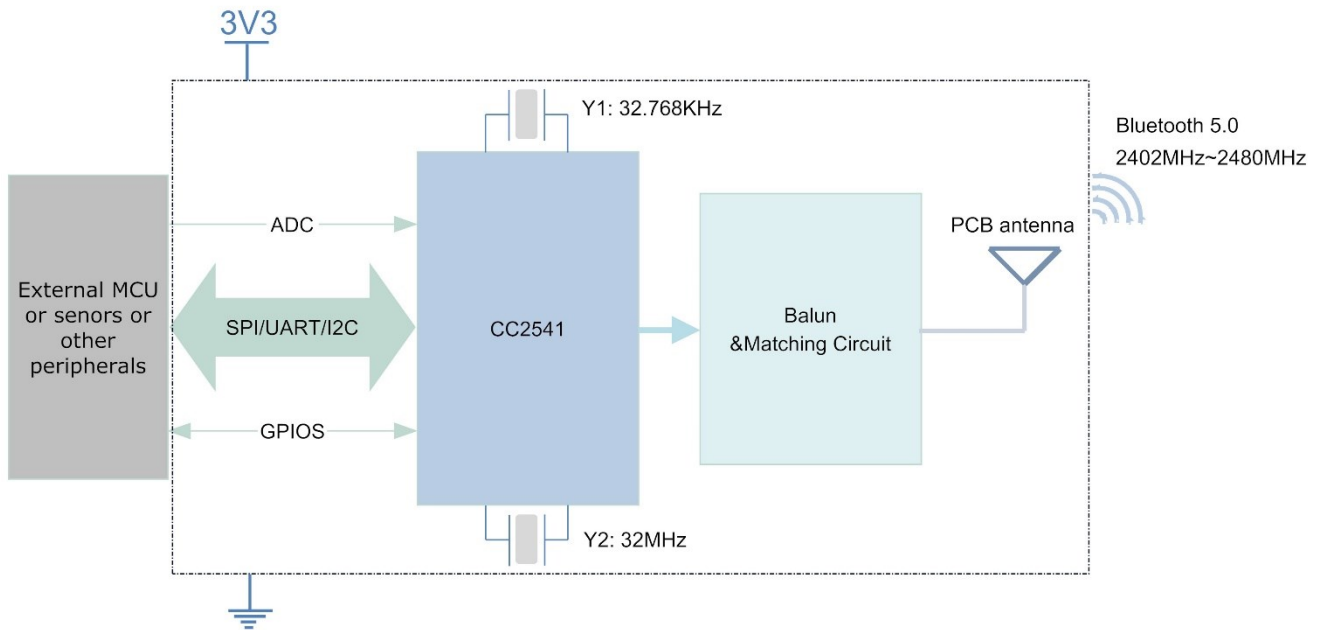

Figure 2-1. The Block Diagram of BDE-BLEM201P

3. Terminal Configuration and Functions

3.1 Pin Diagram

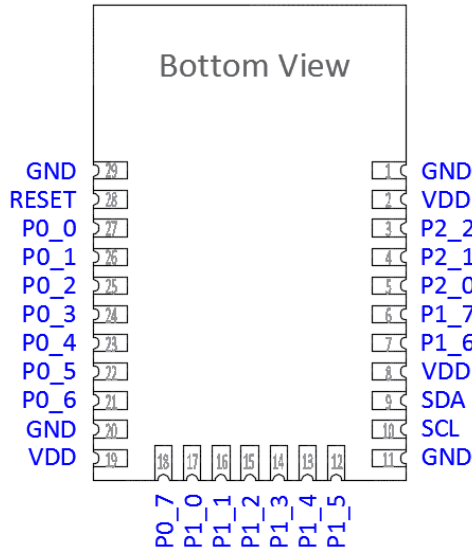

Figure 3-1. Pin Diagram Bottom View

3.2 Pin Attributes and Pin Multiplexing

Table 3-1. Pin Description

Pin #	Pin Name	Type ⁽¹⁾	Description
1	GND	GND	Power ground
2	VDD	POWER	Power supply
3	P2_2	I/O	GPIO
4	P2_1	I/O	GPIO
5	P2_0	I/O	GPIO
6	P1_7	I/O	GPIO
7	P1_6	GND	GPIO
8	VDD	POWER	Power supply
9	SDA	I/O	Serial data of I2C
10	SCL	I	Serial clock of I2C
11	GND	GND	Power ground
12	P1_5	I/O	GPIO
13	P1_4	I/O	GPIO
14	P1_3	I/O	GPIO
15	P1_2	I/O	GPIO
16	P1_1	I/O	GPIO
17	P1_0	I/O	GPIO
18	PO_7	I/O	GPIO
19	VDD	POWER	Power supply
20	GND	GND	Power ground
21	PO_6	I/O	GPIO
22	PO_5	I/O	GPIO
23	PO_4	I/O	GPIO
24	PO_3	I/O	GPIO

Pin #	Pin Name	Type ⁽¹⁾	Description
25	P0_2	I/O	GPIO
26	P0_1	I/O	GPIO
27	P0_0	I/O	GPIO
28	RESET	I	Reset pin, active low
29	GND	GND	Power ground

(1) I = input; O = output; I/O = bidirectional.

Table 3-2. Peripheral IO pin mapping

PERIPHERAL / FUNCTION	P0								P1								P2			
	7	6	5	4	3	2	1	0	7	6	5	4	3	2	1	0	2	1	0	
ADC	A7	A6	A5	A4	A3	A2	A1	A0												
Operational amplifier						O	-	+												
Analog comparator			+	-																
USART 0 SPI Alt. 2			C	SS	MO	MI					MO	MI	C	SS						
USART 0 UART Alt.2			RT	CT	TX	RX					TX	RX	RT	CT						
USART 1 SPI Alt.2			MI	MO	C	SS				MI	MO	C	SS							
USART 1 UART Alt.2			RX	TX	RT	CT				RX	TX	RT	CT							
TIMER 1 Alt.2		4	3	2	1	0														
	3	4													0	1	2			
TIMER 3 Alt.2												1	0							
									1	0										
TIMER 4 Alt.2															1	0				
																			0	
DEBUG																	DC	DD		
OBSSEL											5	4	3	2	1	0				

4. Specifications

4.1 Absolute Maximum Ratings

PARAMETER	MIN	MAX	UNIT
VDD	-0.3	3.9	V
Other Terminals	-0.2	$VDD+0.3 \leq 3.9$	V
Storage temperature	-40	125	°C

4.2 Recommended Operating Conditions

PARAMETER	MIN	TYP	MAX	UNIT
VDD	2	3.3	3.6	V
Operating Temperature	-40	-	85	°C

5. Reference Design

5.1 Design Recommendations

In order to get the best performance when integrating the module to your product, it is advised to use the recommended module location to the respective PCB.

■ Location in X-Y plane

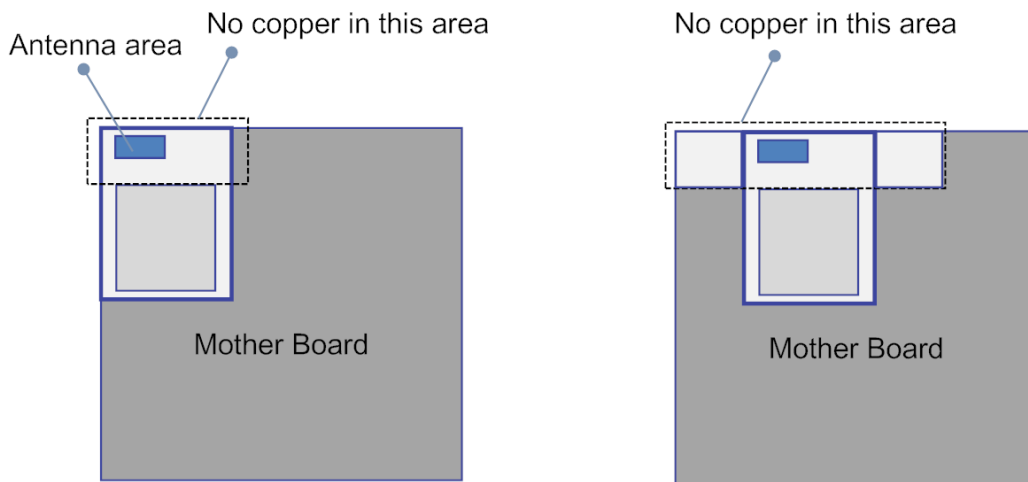

Fig 5-1. Recommended location in X-Y plane

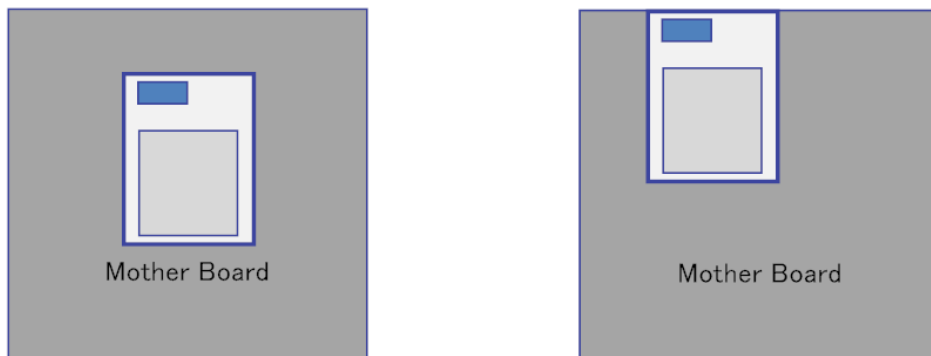

Fig 5-2. Not recommended location in X-Y plane

■ Location in Z plane

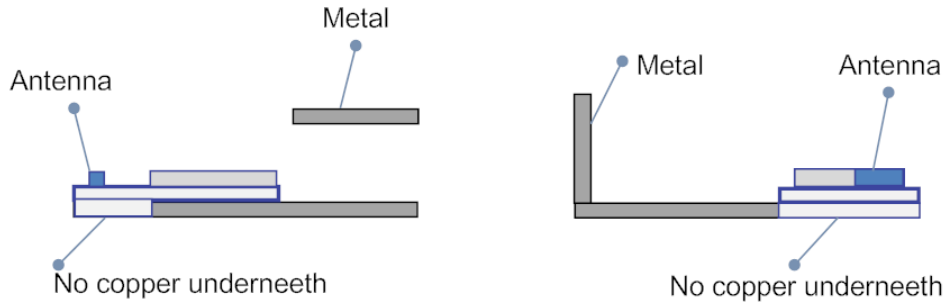

Fig 5-3. Recommended location in Z plane

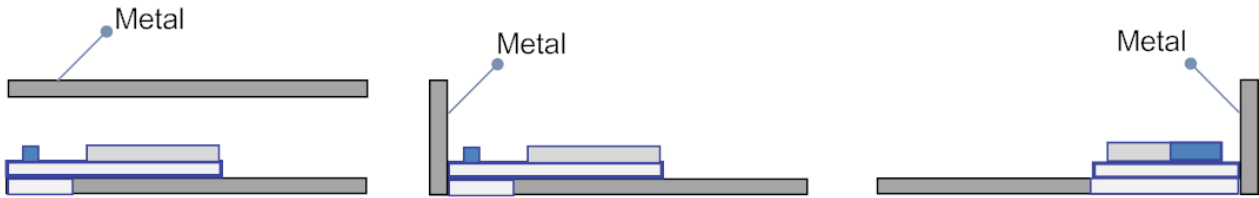

Fig 5-4. Not recommended location in Z plane

6. Typical Solder Reflow Profile

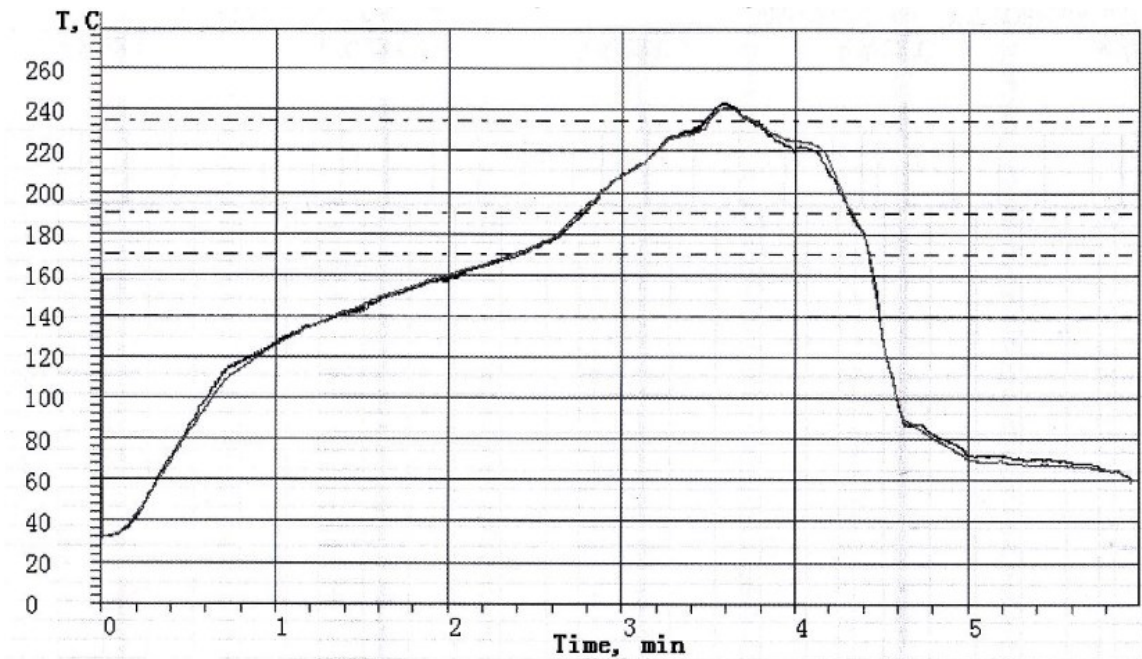

Fig 6-1. Typical Solder Reflow Profile

7. Mechanical Specifications

7.1 Dimensions

The module dimensions are presented in the following figure.

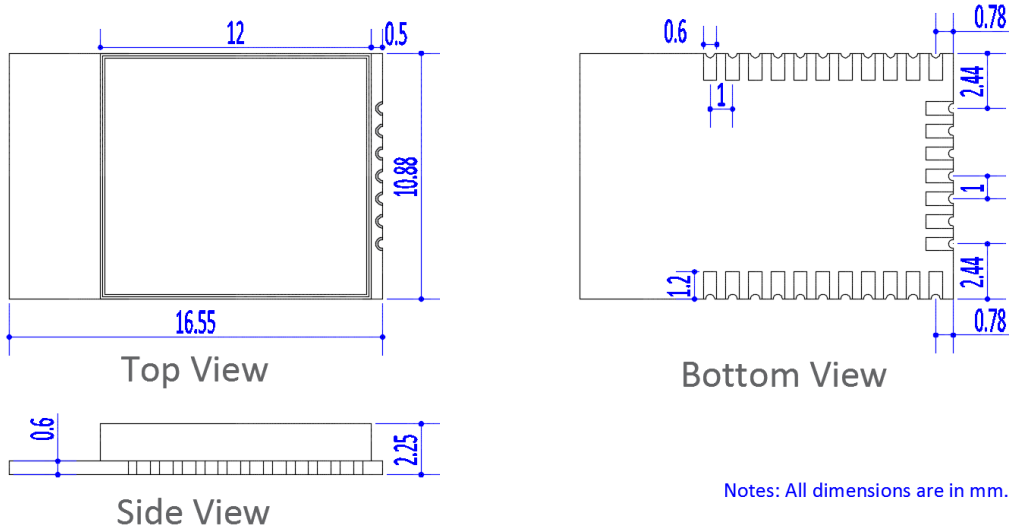

Figure 7-1. Mechanical Drawing

7.2 PCB Footprint

The footprint for the PCB is presented in the following figure.

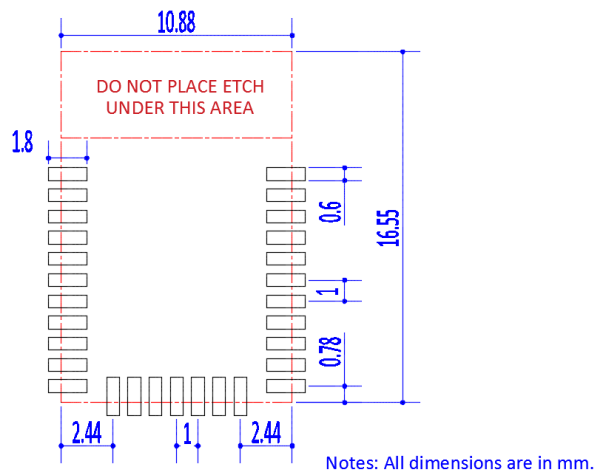

Figure 7-2. Module Footprint Top View

7.3 Marking

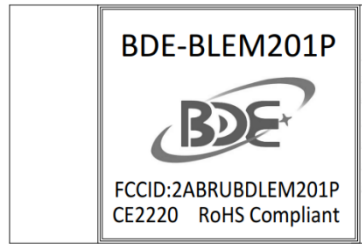

Figure 7-3. Indicative Module Shield Marking

8. Packaging Information



Fig 8-1. Package information

Note

Operation Frequency: 2402 MHz ~ 2480 MHz tune up power with tolerance: $-2\pm 1\text{dBm}$
Sale to all EU countries.

9. Ordering Information

Part Number	Size (mm)	Core Chip	Shipping Form	MOQ
BDE-BLEM201P	10.88 x16.55 x 2.25	CC2541	Tray	1K

10. Revision History

Revision	Date	Description
V1.0	8-Oct-2013	Initial release
V1.1	23-Dec-2014	Editorial correction
V1.2	7-May-2015	Added certification info
V2.0	13-Apr-2021	Replaced template

Contacts

BDE Technology Inc.

China: B2-403, 162 Science Avenue, Huangpu District, Guangzhou 510663, China

Tel: +86-20-28065335

Website: <http://www.bdecomm.com>

Email: shu@bdecomm.com

USA: 67 E Madison St, #1603A, Chicago, IL 60603, US

Tel: +1-312-379-9589

Website: <http://www.bdecomm.com>

Email: info@bdecomm.com