

**P/N: TS8FSDMAR62ISI**  
**TS16FSDMAR62ISI**  
**Industrial Grade SD card**

### **Description**

Transcend's Industrial Temp SD cards combine the advantages of large storage capacity and industrial range (-40°~85°C) operating temperature flexibility, making them the best solution for tough industrial environments where performance and reliability are essential.

### **Features**

- RoHS compliant product
- Compatible with SD Specification Ver. 3.01
- Supports Speed Class Specification up to Class 10
- Manufactured with SLC NAND Flash chips for extra long life and stability
- Support S.M.A.R.T. Function
- Operating Temperature: -40 ~ 85°C
- Mechanical Write Protection Switch
- Built-in ECC and Wear leveling
- Support ESD IEC 61000-4-2

## Architecture

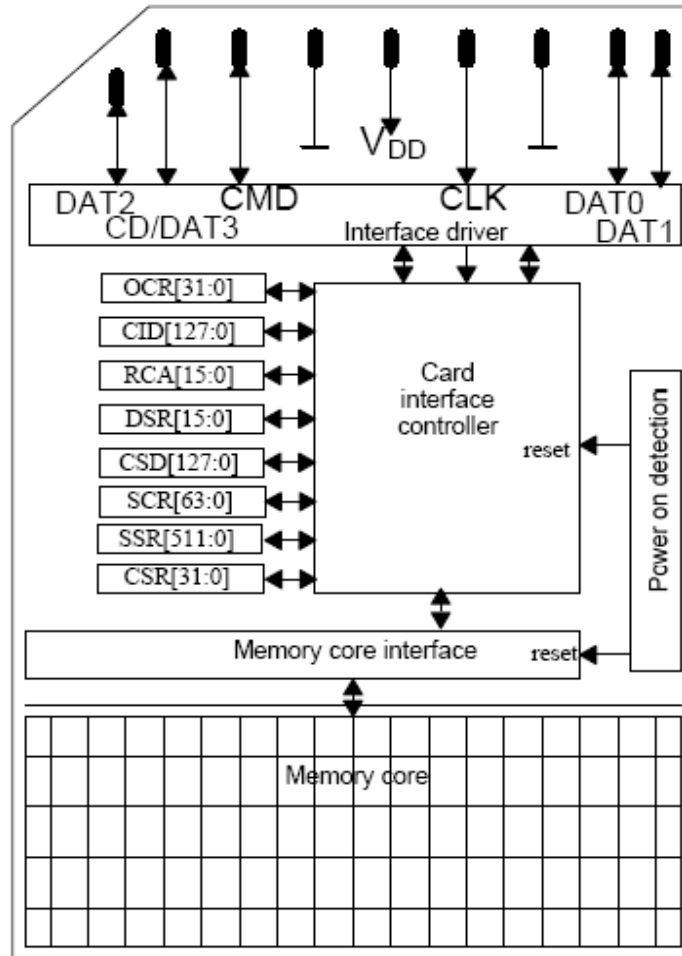

## Pin Definition

| Pin No. | SD Mode          |                              | SPI Mode         |                       |
|---------|------------------|------------------------------|------------------|-----------------------|
|         | Name             | Description                  | Name             | Description           |
| 1       | CD/DAT3          | Card Detect/Data Line [Bit3] | CS               | Reserved              |
| 2       | CMD              | Command/Response             | DI               | Chip Select           |
| 3       | V <sub>SS1</sub> | Supply voltage ground        | V <sub>SS</sub>  | Data In               |
| 4       | V <sub>DD</sub>  | Supply voltage               | V <sub>DD</sub>  | Supply voltage        |
| 5       | CLK              | Clock                        | SCLK             | Clock                 |
| 6       | V <sub>SS2</sub> | Supply voltage ground        | V <sub>SS2</sub> | Supply voltage ground |
| 7       | DAT0             | Data Line [Bit0]             | DO               | Data out              |
| 8       | DAT1             | Data Line [Bit1]             | RSV              | Reserved              |
| 9       | DAT2             | Data Line [Bit2]             | RSV              | Reserved              |

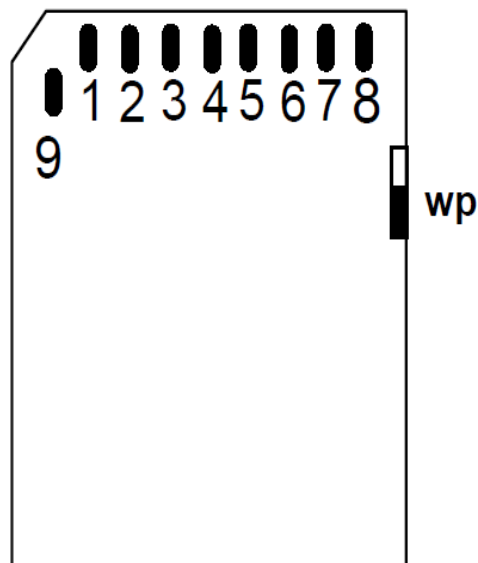

## Specifications

| Physical Specification  |               |             |
|-------------------------|---------------|-------------|
| <b>Form Factor</b>      |               | SD          |
| <b>SD specification</b> |               | SD3.01      |
| <b>Dimensions (mm)</b>  | <b>Length</b> | 32.00 ± 0.1 |
|                         | <b>Width</b>  | 24.00 ± 0.1 |
|                         | <b>Height</b> | 2.10 ± 0.15 |

| Bus Mode/ Power Consumption |       |             |
|-----------------------------|-------|-------------|
|                             |       | Value(Max.) |
| Default Mode<br>(25MHz)     | Read  | 100mA       |
|                             | Write | 100mA       |
|                             | Idle  | 0.5mA       |
| High Speed mode<br>(50MHz)  | Read  | 200mA       |
|                             | Write | 200mA       |
|                             | Idle  | 0.5mA       |

Note: Power consumption is referred to Section 6.6.3 of the SDA Physical Layer Specification, Version 3.01

| Environmental Specifications |                      |
|------------------------------|----------------------|
| Operating Temperature        | - 40°C to 85°C       |
| Storage Temperature          | - 40°C to 85°C       |
| Durability                   | 10.000 mating cycles |
| Drop test                    | 1.5m free fall       |
| Regulator                    | CE/FCC/BSMI          |

## Product Description

### 1.Features

#### **1.1 Lock Function**

Support for password protected locking and unlocking of SD devices. It uses the LOCK/UNLOCK command(CMD42) which is available in SD command sets.

#### **1.2 Built-in ECC Engine**

In event of errors, the combined data allow the recovery of the original data. The number of errors that can be recovered depends on the algorithm used.

#### **1.3 Wear-leveling**

This function means the data are no longer tied to a single physical area, which can extend Card's life expectancy.

#### **1.4 S.M.A.R.T. function**

Transcend Industrial SD Card supports S.M.A.R.T. command (ACMD13) that allows the user to read the health information of the SD. Transcend also define some innovated S.M.A.R.T. features which allows the user to evaluate the status of the SD in a much more efficient way.

| Identifier                       | Length  | Description  |
|----------------------------------|---------|--|
| Min Erase Count-L/H              | 4 Bytes | Min Erase Count-Low Byte /High Byte                                      |
| Max Erase Count-L/H              | 4 Bytes | Max Erase Count-Low Byte /High Byte                                      |
| Abnormal Power Off Count         | 2 Bytes | Abnormal Power Off Count   |
| Health Status (Remain Life in %) | 1 Byte  | $(\text{erase\_count} - \text{avg\_erase\_count}) / \text{erase\_count}$ |
| Total Erase Count                | 4 Bytes | Total Erase Count  |
| Average Erase Count-L/H          | 2 Bytes | Average Erase Count-Low Byte /High Byte                                  |
| RTBB count                       | 2 Bytes | Bad block after SD card used   |
| Spare block count                | 1 Byte  | Spare block count  |

## 2. Bus Topology

The SD Memory Card system defines two alternative communication protocols: SD and SPI. The host system can choose either one of modes. The card detects which mode is request by host when the reset command is received and expects all further communication to be in the same communication mode.

### 2.1 SD Bus

For more details, refer to Section 3.5.1 of the SDA Physical Layer Specification, Version 3.01.

### 2.2 SPI Bus

For more details, refer to Section 3.5.2 of the SDA Physical Layer Specification, Version 3.01.

## 3. SD card Register information

### 3.1 OCR register

The OCR register stores the VDD voltage profile of the card, refer to Section 5.1 of the SDA Physical Layer Specification, Version 3.01 for more information.

### 3.2 CID register

The Card Identification (CID) register is 128 bits wide. It contains the card identification information used during the card identification phase. Every individual flash card shall have a unique identification number. The structure of the CID register is defined in the following paragraphs:

| Name                  | Field | Width | CID-slice |
|-----------------------|-------|-------|-----------|
| Manufacturer ID       | MID   | 8     | [127:120] |
| OEM/Application ID    | OID   | 16    | [119:104] |
| Product name          | PNM   | 40    | [103:64]  |
| Product revision      | PRV   | 8     | [63:56]   |
| Product serial number | PSN   | 32    | [55:24]   |
| reserved              | --    | 4     | [23:20]   |
| Manufacturing date    | MDT   | 12    | [19:8]    |
| CRC7 checksum         | CRC   | 7     | [7:1]     |
| not used, always '1'  | -     | 1     | [0:0]     |

- MID

An 8-bit binary number that identifies the card manufacturer. The MID number is controlled, defined, and allocated to a SD Memory Card manufacturer by the SD-3C, LLC. This procedure is established to ensure uniqueness of the CID register.

- **OID**

A 2-character ASCII string that identifies the card OEM and/or the card contents (when used as a distribution media either on ROM or FLASH cards). The OID number is controlled, defined, and allocated to a SD Memory Card manufacturer by the SD-3C, LLC. This procedure is established to ensure uniqueness of the CID register.

- **PNM**

The product name is a string, 5 ASCII characters long.  
PNM can be customized by Transcend

- **PRV**

The product revision is composed of two Binary Coded Decimal (BCD) digits, four bits each, representing an  $\overline{y}.\overline{w}$  revision number. The  $\overline{y}$  is the most significant nibble and  $\overline{w}$  is the least significant nibble.  
As an example, the PRV binary value field for product revision  $\overline{6}.\overline{1}$  will be: 0110 0010

- **PSN**

The Serial Number is 32 bits of binary number.  
PSN Number can be customized by Transcend

- **MDT**

The manufacturing date composed of two hexadecimal digits, one is 8 bit representing the year(y) and the other is four bits representing the month(m).

The  $\overline{w}$  field [11:8] is the month code. 1 = January.

The  $\overline{y}$  field [19:12] is the year code. 0 = 2000.

As an example, the binary value of the Date field for production date  $\overline{4}$  April  $\overline{1}$  2000 will be:  
00000001 0100.

MDT can be customized by Transcend

- **CRC**

CRC7 checksum (7 bits).

### 3.3 CSD register

The following sections describe the CSD fields and the relevant data types for the standard and High Capacity SD Memory Card. CSD Version 1.0 is applied Capacity SD Memory Card and CSD Version is applied to 2.0 is applied to only the High Capacity SD Memory Card. The field name in parenthesis is set to fixed value and indicates that the host is not necessary to refer these fields. The fixed values enables host, which refers to these fields, to keep compatibility to CSD Version 1.0. The Cell Type field is coded as follows: R = readable, W(1) = writable once, W = multiple writable.



### 3.3.1 CSD Register Structure

| CSD_STRUCTURE | CSD Structure version | Card capacity                       |
|---------------|-----------------------|-------------------------------------|
| 0             | CSD Version1.0        | Standard Capacity                   |
| 1             | CSD Version2.0        | High Capacity and Extended Capacity |
| 2-3           | reserved              |                                     |

### 3.3.2 CSD Register Structure (CSD Version 1.0)

| Name   | Field              | Width | Cell Type | CSD-slice |
|--|--------------------|-------|-----------|-----------|
| CSD structure                                    | CSD_STRUCTURE      | 2     | R         | [127:126] |
| reserved   | -                  | 6     | R         | [125:120] |
| data read access-time-1                          | TAAC               | 8     | R         | [119:112] |
| data read access-time-2 in CLK cycles (NSAC*100) | NSAC               | 8     | R         | [111:104] |
| max. data transfer rate                          | TRAN_SPEED         | 8     | R         | [103:96]  |
| card command classes                             | CCC                | 12    | R         | [95:84]   |
| max. read data block length                      | READ_BL_LEN        | 4     | R         | [83:80]   |
| partial blocks for read allowed                  | READ_BL_PARTIAL    | 1     | R         | [79:79]   |
| write block misalignment                         | WRITE_BLK_MISALIGN | 1     | R         | [78:78]   |
| read block misalignment                          | READ_BLK_MISALIGN  | 1     | R         | [77:77]   |
| DSR implemented                                  | DSR_IMP            | 1     | R         | [76:76]   |
| reserved   | -                  | 2     | R         | [75:74]   |
| device size                                      | C_SIZE             | 12    | R         | [73:62]   |
| max. read current @VDD min                       | VDD_R_CURR_MIN     | 3     | R         | [61:59]   |
| max. read current @VDD max                       | VDD_R_CURR_MAX     | 3     | R         | [58:56]   |
| max. write current @VDD min                      | VDD_W_CURR_MIN     | 3     | R         | [55:53]   |
| max. write current @VDD max                      | VDD_W_CURR_MAX     | 3     | R         | [52:50]   |

| Name                                      | Field              | Width | Cell Type | CSD-slice |
|---|--------------------|-------|-----------|-----------|
| device size multiplier                    | C_SIZE_MULT        | 3     | R         | [49:47]   |
| erase single block enable                 | ERASE_BLK_EN       | 1     | R         | [46:46]   |
| erase sector size                         | SECTOR_SIZE        | 7     | R         | [45:39]   |
| write protect group size                  | WP_GRP_SIZE        | 7     | R         | [38:32]   |
| write protect group enable                | WP_GRP_ENABLE      | 1     | R         | [31:31]   |
| reserved for MultiMediaCard compatibility |                    | 2     | R         | [30:29]   |
| write speed factor                        | R2W_FACTOR         | 3     | R         | [28:26]   |
| max. write data block length              | WRITE_BL_LEN       | 4     | R         | [25:22]   |
| partial blocks for write allowed          | WRITE_BL_PARTIAL   | 1     | R         | [21:21]   |
| reserved                                  | -                  | 5     | R         | [20:16]   |
| File format group                         | FILE_FORMAT_GRP    | 1     | R/W(1)    | [15:15]   |
| copy flag (OTP)                           | COPY               | 1     | R/W(1)    | [14:14]   |
| permanent write protection                | PERM_WRITE_PROTECT | 1     | R/W(1)    | [13:13]   |
| temporary write protection                | TMP_WRITE_PROTECT  | 1     | R/W       | [12:12]   |
| File format                               | FILE_FORMAT        | 2     | R/W(1)    | [11:10]   |
| reserved                                  |                    | 2     | R/W       | [9:8]     |
| CRC                                       | CRC                | 7     | R/W       | [7:1]     |
| not used, always '1'                      | -                  | 1     | -         | [0:0]     |

### 3.3.3 CSD Register (CSD Version 2.0)

| Name   | Field                | Width | Value         | Cell Type | CSD-slice |
|--|----------------------|-------|---------------|-----------|-----------|
| CSD structure                                  | CSD_STRUCTURE        | 2     | 01b           | R         | [127:126] |
| reserved                                       | -                    | 6     | 00 0000b      | R         | [125:120] |
| data read access-time                          | (TAAC)               | 8     | 0Eh           | R         | [119:112] |
| data read access-time in CLK cycles (NSAC*100) | (NSAC)               | 8     | 00h           | R         | [111:104] |
| max. data transfer rate                        | (TRAN_SPEED)         | 8     | 32h or 5Ah    | R         | [103:96]  |
| card command classes                           | CCC                  | 12    | 01x110110101b | R         | [95:84]   |
| max. read data block length                    | (READ_BLK_LEN)       | 4     | 9             | R         | [83:80]   |
| partial blocks for read allowed                | (READ_BLK_PARTIAL)   | 1     | 0             | R         | [79:79]   |
| write block misalignment                       | (WRITE_BLK_MISALIGN) | 1     | 0             | R         | [78:78]   |
| read block misalignment                        | (READ_BLK_MISALIGN)  | 1     | 0             | R         | [77:77]   |
| DSR implemented                                | DSR_IMP              | 1     | x             | R         | [76:76]   |
| reserved                                       | -                    | 6     | 00 0000b      | R         | [75:70]   |
| device size                                    | C_SIZE               | 22    | 00 xxxxh      | R         | [69:48]   |
| reserved                                       | -                    | 1     | 0             | R         | [47:47]   |
| erase single block enable                      | (ERASE_BLK_EN)       | 1     | 1             | R         | [46:46]   |
| erase sector size                              | (SECTOR_SIZE)        | 7     | 7Fh           | R         | [45:39]   |
| write protect group size                       | (WP_GRP_SIZE)        | 7     | 0000000b      | R         | [38:32]   |
| write protect group enable                     | (WP_GRP_ENABLE)      | 1     | 0             | R         | [31:31]   |
| reserved                                       | -                    | 2     | 00b           | R         | [30:29]   |
| write speed factor                             | (R2W_FACTOR)         | 3     | 010b          | R         | [28:26]   |
| max. write data block length                   | (WRITE_BLK_LEN)      | 4     | 9             | R         | [25:22]   |
| partial blocks for write allowed               | (WRITE_BLK_PARTIAL)  | 1     | 0             | R         | [21:21]   |
| reserved                                       | -                    | 5     | 00000b        | R         | [20:16]   |
| File format group                              | (FILE_FORMAT_GRP)    | 1     | 0             | R         | [15:15]   |
| copy flag (OTP)                                | COPY                 | 1     | x             | R/W(1)    | [14:14]   |
| permanent write protection                     | PERM_WRITE_PROTECT   | 1     | x             | R/W(1)    | [13:13]   |
| temporary write protection                     | TMP_WRITE_PROTECT    | 1     | x             | R/W       | [12:12]   |
| File format                                    | (FILE_FORMAT)        | 2     | 00b           | R         | [11:10]   |
| reserved                                       | -                    | 2     | 00b           | R         | [9:8]     |
| CRC  | CRC                  | 7     | xxxxxxxh      | R/W       | [7:1]     |
| not used, always '1'                           | -                    | 1     | 1             | -         | [0:0]     |

### 3.4 RCA register

The writable 16-bit relative card address register carries the card address that is published by the card during the card identification. Refer to Section 5.4 in the SDA Physical Layer Specification, Version 3.01 for more information.

### 3.5 SCR register

In addition to the CSD register, there is another configuration register named SD CARD configuration Register, SCR provide information on the SD memory card's special feature that were configured into the given card. Refer to Section 5.6 in the SDA Physical Layer Specification, Version 3.01 for more information.

### 3.6 SSR register

The SD status contains status bits that are related to the SD memory card proprietary features and may be used for future application-specific usage. The SD Status structure is described in Section 4.10.2 in the SDA Physical Layer Specification, Version 3.01.

The above technical information is based on industry standard data and has been tested to be reliable. However, Transcend makes no warranty, either expressed or implied, as to its accuracy and assumes no liability in connection with the use of this product. Transcend reserves the right to make changes to the specifications at any time without prior notice.

All rights reserved. Transcend and the Transcend logo are registered trademarks of Transcend Information, Inc. Product offerings and specifications are subject to change without notice. All other products, brand names, company names and logos are trademarks of their respective owners.

