

HF/VHF/UHF RF power N-channel MOSFET

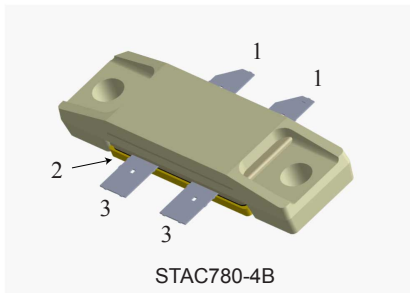

Pin connection	
Pin	Connection
1	Drain
2	Source (bottom side)
3	Gate

Features

Order code	Frequency	V _{DD}	P _{OUT}	Gain	Efficiency
STAC2942BW	175 MHz	50 V	350 W	21 dB	60 %

- Gold metallization
- Excellent thermal stability
- Common source push-pull configuration
- P_{OUT} = 350 W min. with 21 dB gain at 175 MHz
- In compliance with the 2002/95/EC European directive
- ST air-cavity STAC packaging technology

Description

The **STAC2942B** is a gold metallized N-channel MOS field-effect RF power transistor, intended for use in 50 V DC large signal applications up to 250 MHz.



Product status link
STAC2942B

Product summary	
Order code	STAC2942BW
Marking	STAC2942
Package	STAC780-4B
Packing	Box
Base / Bulk qty	20 / 80

1 Electrical data

1.1 Maximum ratings

Table 1. Absolute maximum ratings (T_{CASE} = 25 °C)

Symbol	Parameter	Value	Unit
V _{(BR)DSS} ⁽¹⁾	Drain source voltage	130	V
V _{DRG} ⁽¹⁾	Drain-gate voltage (R _{GS} = 1 MΩ)	130	V
V _{GS}	Gate-source voltage	±20	V
I _D	Drain current	40	A
P _{DISS}	Power dissipation	625	W
T _J	Maximum operating junction temperature	200	°C
T _{STG}	Storage temperature range	-65 to +150	°C

1. T_J = 150 °C

1.2 Thermal data

Table 2. Thermal data

Symbol	Parameter	Value	Unit
R _{thJC}	Junction-case thermal resistance	0.28	°C/W

1.3 ESD protection characteristics

Table 3. ESD protection

Symbol	Test Methodology	Class
HBM	Human Body Model (per JESD22-A114)	2

2 Electrical characteristics

($T_{CASE} = +25\text{ }^{\circ}\text{C}$, unless otherwise specified)

2.1 Static

Table 4. Static (per side)

Symbol	Parameter	Test conditions	Min.	Typ.	Max.	Unit
$V_{(BR)DSS}$	Drain - Source Breakdown voltage	$V_{GS} = 0\text{ V}$, $I_{DS} = 100\text{ mA}$, $T_J = 150\text{ }^{\circ}\text{C}$	130			V
I_{DSS}	Zero gate voltage drain Leakage Current	$V_{GS} = 0\text{ V}$, $V_{DS} = 50\text{ V}$			100	μA
I_{GSS}	Gate - Source leakage current	$V_{GS} = 20\text{ V}$, $V_{DS} = 0\text{ V}$			250	nA
$V_{GS(Q)}$	Gate quiescent voltage	$V_{DS} = 10\text{ V}$, $I_D = 250\text{ mA}$	1.5	2.5	4.0	V
$V_{DS(ON)}$	Drain - Source on voltage	$V_{GS} = 10\text{ V}$, $I_D = 10\text{ A}$			3	V
G_{FS}	Forward transconductance	$V_{DS} = 10\text{ V}$, $I_D = 5\text{ A}$	5			S
C_{ISS}	Input capacitance	$V_{DS} = 50\text{ V}$, $f = 1\text{ MHz}$		425		pF
C_{OSS}	Output capacitance			202		pF
C_{RSS}	Reverse transfer capacitance			12		pF

2.2 Dynamic

Table 5. Dynamic ⁽¹⁾

Symbol	Parameter	Test conditions	Min.	Typ.	Max.	Unit
P_{OUT}	Output power	$P_{IN} = 4\text{ W}$	350	450	-	W
η_D	Drain efficiency	$P_{IN} = 4\text{ W}$	60	75	-	%
VSWR	Load mismatch	$P_{OUT} = 350\text{ W}$, all phases angles			5:1	

1. $F = 175\text{ MHz}$, $V_{DD} = 50\text{ V}$, $I_{DQ} = 2 \times 250\text{ mA}$.

3 Impedance

Figure 1. Current conventions

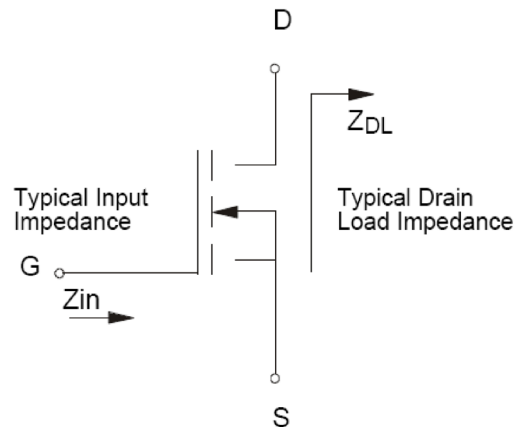

GADG170720191138MT

Table 6. Impedance data

Freq. (MHz)	$Z_{IN} (\Omega)$	$Z_{DL}(\Omega)$
175	$2.0 - j2.0$	$3.5 + j 5.2$

Note: Measured gate-to-gate and drain-to-drain, respectively, balanced configuration.

4 Typical performance

Figure 2. Capacitances versus drain supply voltage

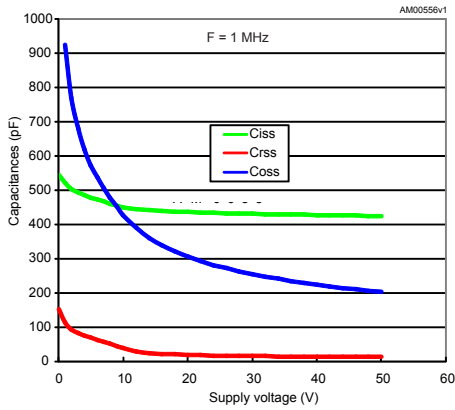

Figure 3. Output power versus drain supply voltage

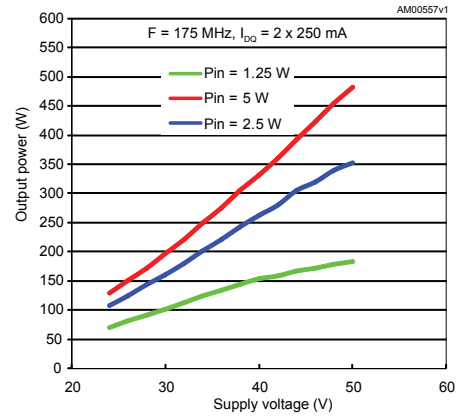

Figure 4. Output power versus gate voltage

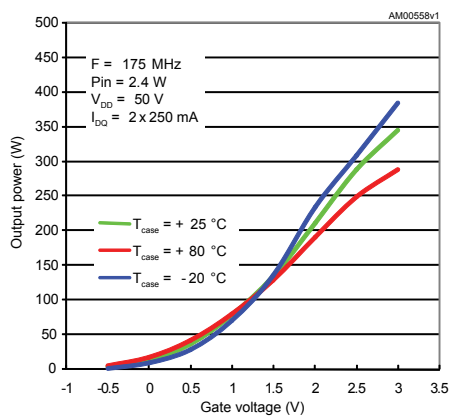

Figure 5. Output power versus input power

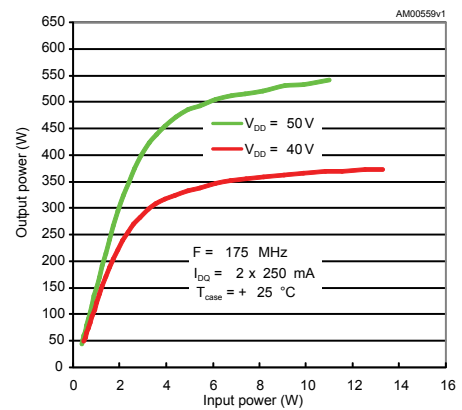

Figure 6. Output power vs input power and case temperature

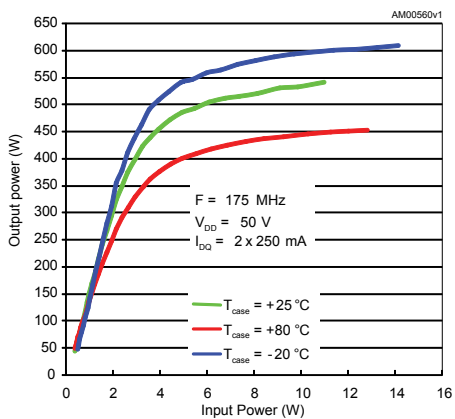

Figure 7. Efficiency vs output power and case temperature

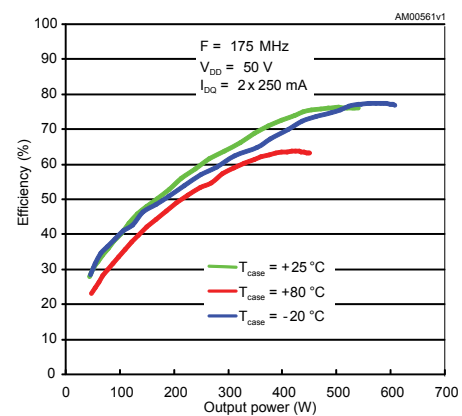

Figure 8. Power gain vs output power and case temperature

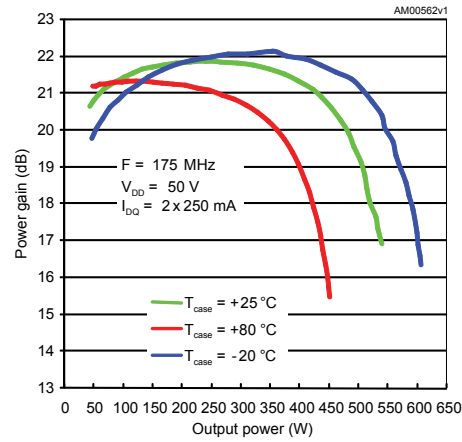

Figure 9. Safe operating area

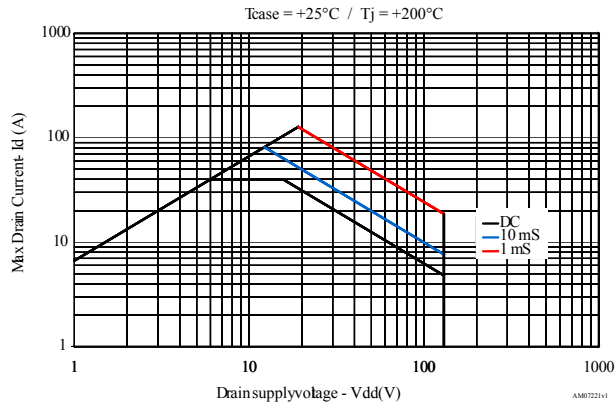

Figure 10. Transient thermal impedance

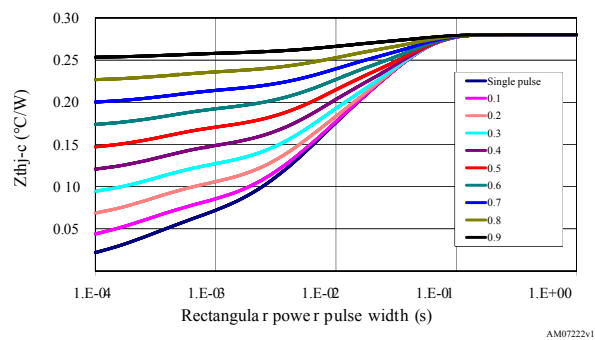
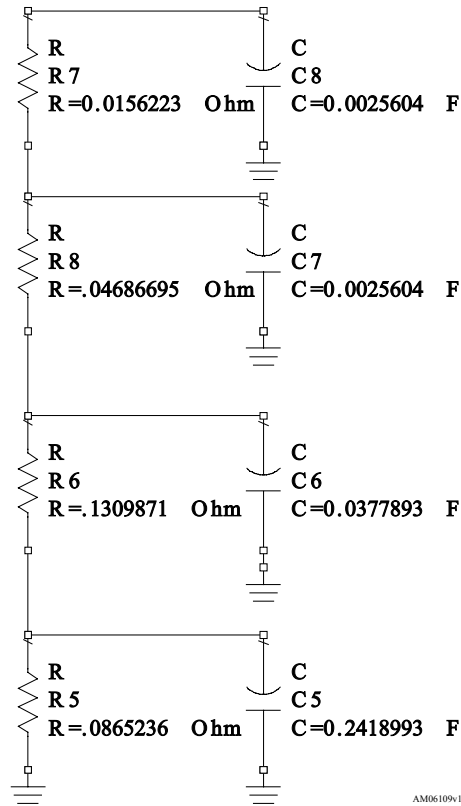

Figure 11. Transient thermal model



5 Test circuit

5.1 Electrical schematic and BOM

Figure 12. 175 MHz test circuit schematic (production test circuit)

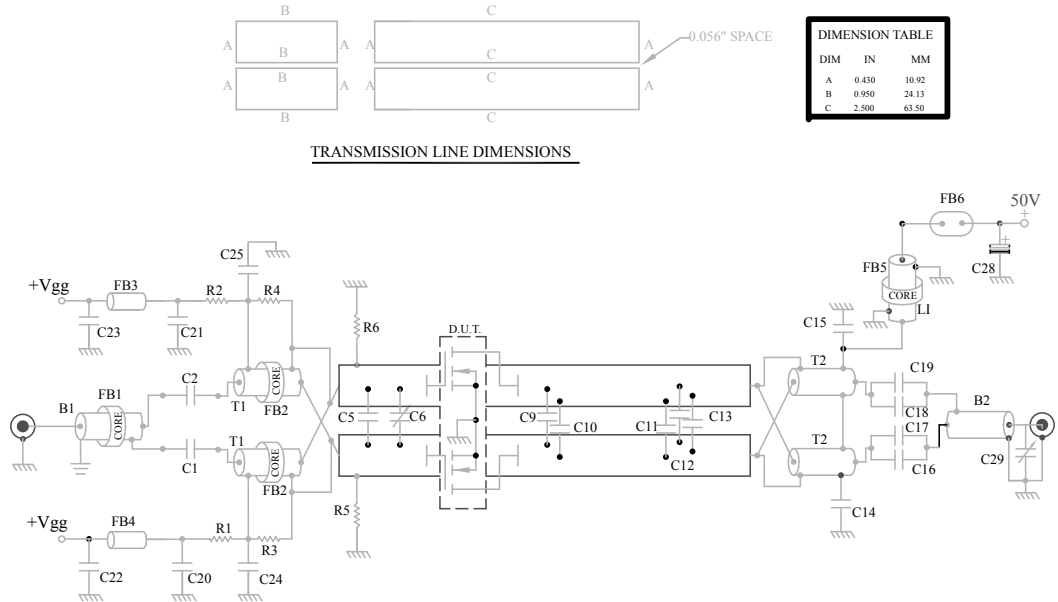

NOTES:

1. DIMENSIONS AT COMPONENT SYMBOLS ARE REFERENCE FOR COMPONENT PLACEMENT. SEE SHEET 1.
2. GAP BETWEEN GROUND & TRANSMISSION LINES IS 0.056[1.42] TYP

AM00528v1

Table 7. 175 MHz test circuit component list

Component	Description
C1, C2, C14, C15, C24, C25	1200 pF ATC 700B chip capacitor
C5	75 pF ATC 100B chip capacitor
C6	ST406 variable capacitor
C9, C10	47 pF ATC 100B chip capacitor
C11, C12, C13	43 pF ATC 100B chip capacitor
C16, C18	470 pF ATC 100B chip capacitor
C17, C19, C20, C21	10,000 pF ATC 200B chip capacitor
C22, C23	0.1 μ F 200 V chip capacitor
C28	10 μ F 100 V electrolytic capacitor
C29	0.8 - 8 pF variable capacitor
R1, R2, R5, R6	430 Ω , 1/2 W chip resistor
R3, R4	270 Ω 1/2 W axial lead resistor
B1	RG-316 50 Ω 11.8" through ferrite toroid
B2	RG-142 50 Ω 11.8"
T1	4:1, RG-316 25 Ω , 5.9", 2 turns thru ferrite core
T2	1:4, 25 Ω semi-rigid cable, OD .141", 5.9"
L1	$\lambda/4$ inductor, RG-142 50 Ω , 11.8", 3 turns thru ferrite toroid
FB1,FB5	Ferrite toroid
FB2, FB6	Multi-aperture core
FB3, FB4	Surface mount ferrite bead
PCB	Rogers ultralam 2000, Er 2.55, .060"

5.2 Test circuit layout

Figure 13. Test circuit

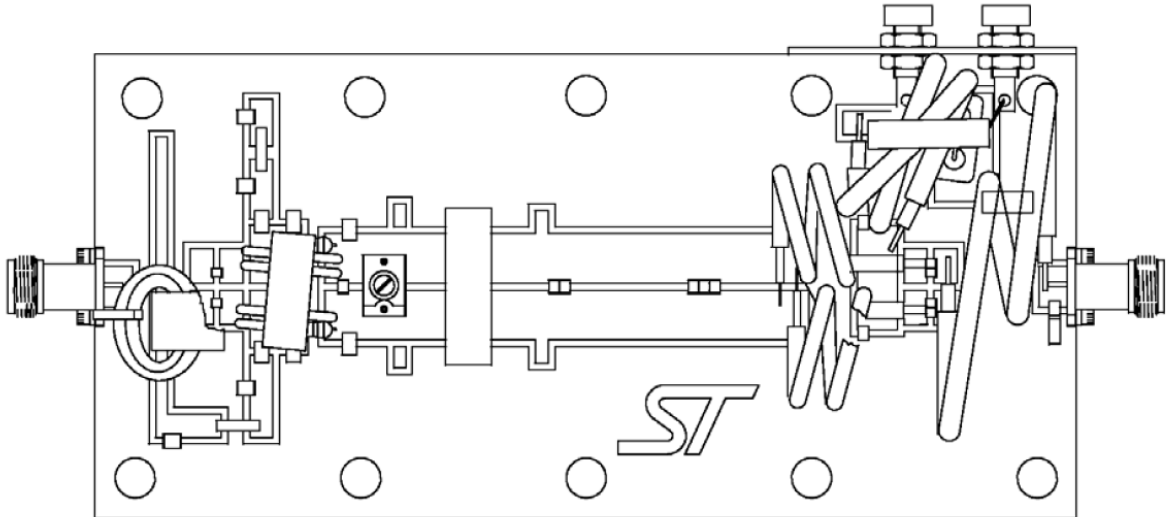

6 Package information

In order to meet environmental requirements, ST offers these devices in different grades of **ECOPACK** packages, depending on their level of environmental compliance. ECOPACK specifications, grade definitions and product status are available at: www.st.com. ECOPACK is an ST trademark.

6.1 STAC780-4B package information

Figure 14. STAC780-4B package outline

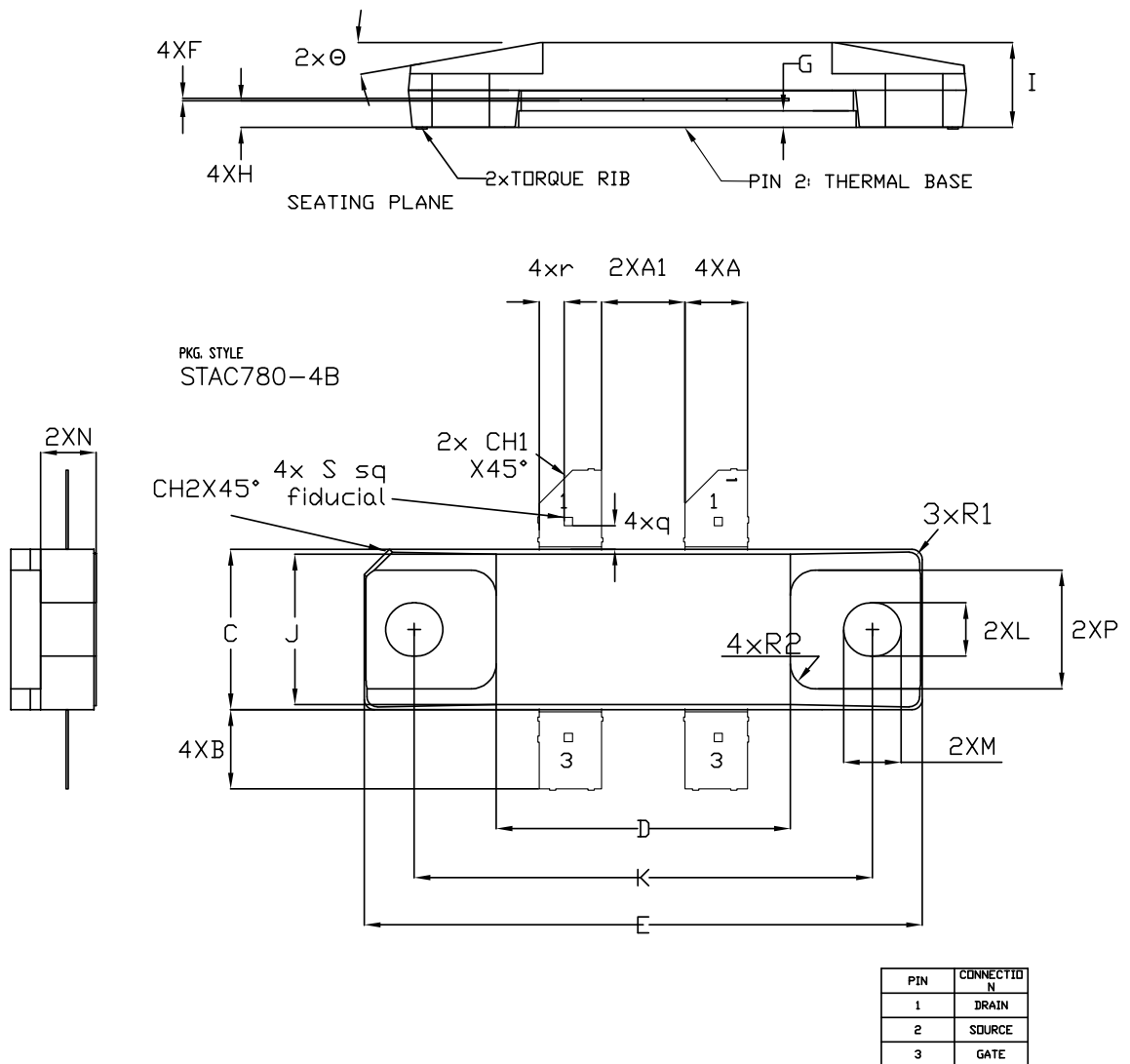

DM00481937 rev.2

Table 8. STAC780-4B mechanical data

Symbol	Millimeters		
	Min	Typ	Max
A	3.76		3.86
A1	5.03		5.13
B	4.57		5.08
C	9.65		9.91
D	17.78		18.08
E	33.88		34.19
F	0.13		0.18
G	0.97		1.14
H	1.52		1.70
I	4.83		5.33
J	9.52		9.78
K	27.69		28.19
L	3.20	3.25	3.30
M	3.43	3.51	3.58
M	3.30	3.38	3.45
p	7.14	7.21	7.29
q		1.45	
R1		0.64	
R2		1.52	
r		1.52	
s		0.51	
Θ		10°	
CH1		2.03	
CH2		1.52	

6.2 Marking information

Figure 15. Marking information

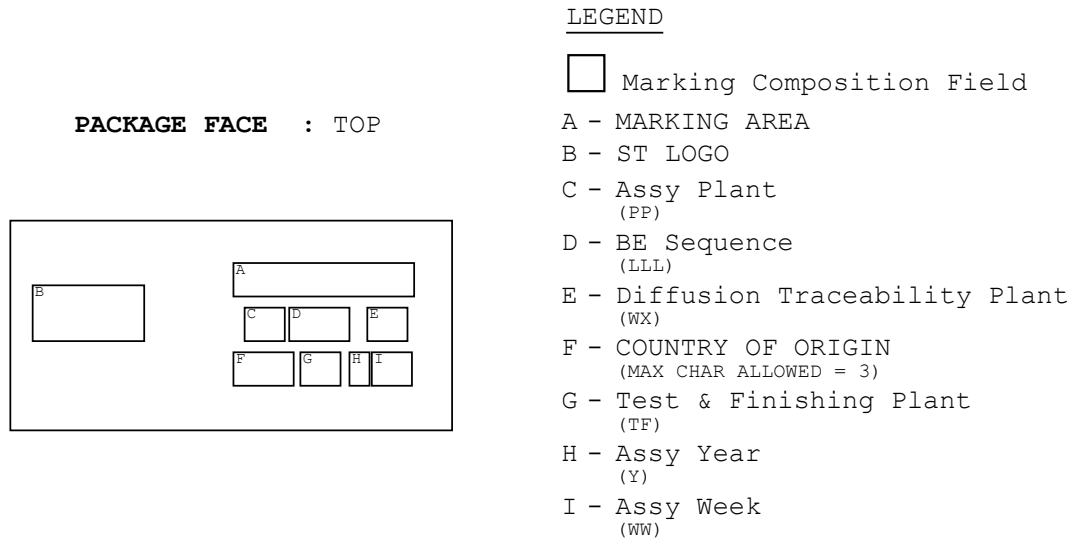

Revision history

Table 9. Document revision history

Date	Version	Changes
20-Mar-2009	1	First release.
16-Apr-2010	2	Added Figure 10, Figure 11 and Figure 12.
12-Aug-2011	3	Update figures on coverpage and Section 6: Package mechanical data. Inserted Section 7: Marking, packing and shipping specifications.
05-Sep-2011	4	Update L and M dimensions Table 8 on page 13.
11-Oct-2011	5	Updated order code in Table 1: Device summary and Table 9: Packing and shipping specifications. Updated Table 10: Marking specifications and Figure 16: Marking layout. Modified document title.
17-Jan-2012	6	Updated Table 5: Dynamic new "load mismatch" has been inserted.
27-Jan-2014	7	Modified pin labeling in Figure 1: Pin connection.
03-Apr-2020	8	Updated package information. Added Section 1.3 ESD protection characteristics .

Contents

1	Electrical data	2
1.1	Maximum ratings	2
1.2	Thermal data	2
1.3	ESD protection characteristics	2
2	Electrical characteristics	3
2.1	Static	3
2.2	Dynamic	3
3	Impedance	4
4	Typical performance	5
5	Test circuit	8
5.1	Electrical schematic and BOM	8
5.2	Test circuit layout	10
6	Package information	11
6.1	STAC780-4B package information	11
6.2	Marking information	13
	Revision history	14
	Contents	15

IMPORTANT NOTICE – PLEASE READ CAREFULLY

STMicroelectronics NV and its subsidiaries (“ST”) reserve the right to make changes, corrections, enhancements, modifications, and improvements to ST products and/or to this document at any time without notice. Purchasers should obtain the latest relevant information on ST products before placing orders. ST products are sold pursuant to ST’s terms and conditions of sale in place at the time of order acknowledgement.

Purchasers are solely responsible for the choice, selection, and use of ST products and ST assumes no liability for application assistance or the design of Purchasers’ products.

No license, express or implied, to any intellectual property right is granted by ST herein.

Resale of ST products with provisions different from the information set forth herein shall void any warranty granted by ST for such product.

ST and the ST logo are trademarks of ST. For additional information about ST trademarks, please refer to www.st.com/trademarks. All other product or service names are the property of their respective owners.

Information in this document supersedes and replaces information previously supplied in any prior versions of this document.

© 2020 STMicroelectronics – All rights reserved