

SLQ-QT500 Liquid Flow Meter

High Purity Flow Meter for High Viscosity Applications

- Liquid flow rates up to 120 ml/min
- Dual calibration for IPA and H₂O
- Response time < 50 ms
- Straight flow channel, no moving parts
- For a wide range of viscosities
- Inert wetted materials (PFA, Quartz)



Product Summary

The SLQ-QT500 Liquid Flow Meter enables fast, non-invasive measurements of liquids for demanding high purity applications. Dual calibration (water, H₂O; and isopropyl alcohol, IPA) allows flow monitoring for water-based or hydrocarbon-based liquids. The straight wetted flow path has no moving parts and is only made of PFA and Quartz. Its excellent chemical compatibility makes the SLQ-QT500 the first choice, even for measuring aggressive chemicals. The flow meter's micro-thermal technology, in combination with the straight and obstacle-free flow path, makes it the ideal solution for high-viscosity liquids.

Interface Options

Digital

- I²C-Bus
- RS485-Bus
- USB cable

Analog

- Voltage output (0-10 V)
- Current output (4-20 mA)
- Additional operation modes

For more information on communication, please refer to page 6 of this document.

Benefits of Sensirion's CMOSens® Technology

- High reliability and long-term stability
- Industry-proven technology with a track record of more than 10 years
- Designed for mass production
- Low signal noise

Content

1 Sensor Performance	3
2 Specifications	4
3 Sensor Output Signal Description	5
4 Communication Interface Description	6
5 Fluidic Specification and Connections	7
6 Mechanical Specifications	8
7 Cleanliness of Flow Path	9
8 Ordering Information	10
9 CE, REACH, RoHS, and WEEE	10
10 Important Notices	11
11 Headquarters and Subsidiaries	12

1 Sensor Performance

Parameter	SLQ-QT500 (IPA)	SLQ-QT500 (H ₂ O)	Unit
Full scale flow rate	2000 (120)	2000 (120)	μl/s (ml/min)
Flow meter output limit ¹	2500 (150)	2500 (150)	μl/s (ml/min)
Accuracy below full scale ² (whichever error is larger)	5	5 ³	% of measured value
	0.125	0.125	% of full scale
Repeatability below full scale (whichever error is larger)	0.5	0.5	% of measured value
	0.0125	0.0125	% of full scale
Temperature coefficient (additional error per °C; whichever is larger)	0.15	0.15	% measured value / °C
	0.00375	0.00375	% full scale / °C
Mounting orientation sensitivity ⁴	2.5	1.0	% of full scale

Table 1: Performance of the SLQ-QT500 (all data for medium IPA, 23°C, unless otherwise noted)

1.1 Specification Charts

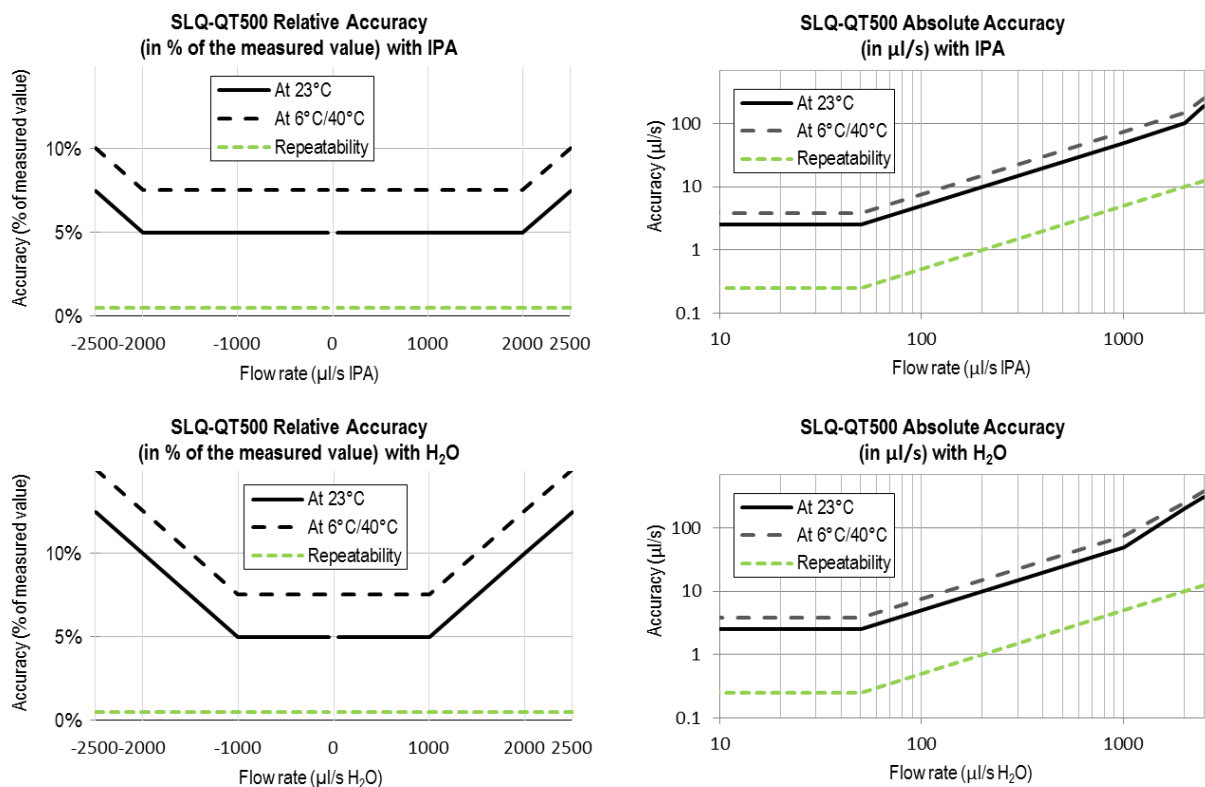

Figure 1: Flow meter accuracy and repeatability across the flow range. Relative error in % of measured value (left column) and absolute error in μl/s (right column) for IPA (top) and H₂O (bottom)

¹ Flow rate at which the flow meter output saturates

² Accuracy with straight inlet tube

³ Accuracy below ±1000 μl/s. See the charts for the accuracy specification between 1000 μl/s and 2500 μl/s

⁴ Maximum additional offset when mounted vertically

2 Specifications

2.1 Electrical Specifications

This section describes the electrical specification when connecting directly to the sensor's M8 connector for I²C communication. The preferred mode of communication is via the SCC1 interface cables. See the respective SCC1 cable datasheets for further details.

Parameter	Symbol	Conditions	Min.	Typical	Max.	Units	Comments
Supply voltage DC	VDD		3.3	3.5	3.7	V	
Supply current	IDD	Measurement		5.1	6.5	mA	VDD = 3.5 V

Table 2: DC characteristics

2.2 Timing Specifications

Parameter	Symbol	Min.	Typical	Max.	Units	Comments
Power-up time	t _{PU}			25	ms	Time to sensor ready
Flow detection response time			<50		ms	Response time to flow changes (τ ₆₃)
I ² C SCL frequency	f _{I2C}		100	400	kHz	
Readout frequency		12.5	200	1000	Hz	Depending on Resolution setting. Sampling time for 9 bit resolution: 1 ms, for 16 bit resolution: 74 ms.

Table 3: Timing specifications

2.3 Absolute Minimum and Maximum Ratings

Parameter	Rating	Unit
Operating temperature	+5 ... +50 (+41 ... +122)	°C (°F)
Operating humidity	0...95 %, non-condensing	% RH
Short term storage temperature ⁵	-10 ... +60 (+14 ... +140)	°C (°F)
Short term storage humidity ⁵	0...95 %, non-condensing	% RH
Maximum supply voltage	4.0	V

Table 4: Absolute minimum and maximum ratings

2.4 Electrical Connector and Pinout

The flow meter is equipped with a male connector type M8, 4-pin, threaded lock according to IEC 61076-2-101 (Ed. 1)/ IEC 60947-5-2, and is compatible with Sensirion's SCC1 interface cables.

Pin	
1	SDA (data)
2	GND
3	VDD
4	SCL (clock)

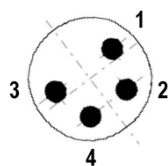

Table 5: Electrical pinout

⁵ Flow path empty. Short term storage refers to temporary conditions during e.g. transport.

3 Sensor Output Signal Description

3.1 Calibration Field Information

The SLQ-QT500 Liquid Flow meter holds two calibrations, one for isopropyl alcohol (IPA) and one for water. Each calibration is stored on a separate calibration field (CF):

- Calibration field 0: IPA (factory default)
- Calibration field 2: H₂O

The default calibration field (i.e. the active calibration field at power up) can be permanently changed via I²C or RS485 commands. Alternatively, the default calibration field can be changed using the USB-RS485 Sensor Viewer which is part of the Flow Meter Kit and also available in the download center on the Sensirion liquid flow webpage.

www.sensirion.com/liquidflow-download

The standard calibrations cover the flow range from -2500 µl/s to +2500 µl/s. Extended calibration ranges for both IPA and water are available on request.

3.2 Sensor Measurement Configuration

The default configuration of the SLQ-QT500 sensor's micro-heater is optimized for the measurement of short dispensing processes. For measuring continuous flow rates, a different setting for the micro-heater is preferred. The default setting can be permanently changed via I²C or RS485 commands. Alternatively, the default heater setting can be changed using the USB-RS485 Sensor Viewer software.

4 Communication Interface Description

The preferred mode of operation for the SLQ-QT500 flow meter is via the digital RS485, analog 0-10 V, or analog 4-20 mA SCC1 interface cables.

4.1 Digital Communication via RS485-Bus

The SCC1-RS485 Sensor Cable for liquid flow meters provides communication via the RS485 interface for use in a demanding industrial automation environment. In addition to the standard commands available in the I²C interface of the flow meter, the incorporated microcontroller of the cable provides more complex logic such as a dispense volume totalizer, automatic dispense detection, automatic heater control and a data buffer for asynchronous readout.

For further information please see the SCC1-RS485 Sensor Cable datasheet, available on www.sensirion.com/liquidflow-download.

4.2 Analog 0-10 V Communication

The SCC1-ANALOG Sensor Cable allows simple and quick readout of Sensirion's liquid flow meters by converting the digital flow meter reading to an 0...10 V voltage output. The output scaling of the cable can be configured by the user and the cable additionally features a configurable digital (high/low) output with two different modes of operation (Flow Switch / Volume Counter).

For further information please see the SCC1-ANALOG Sensor Cable datasheet, available on www.sensirion.com/liquidflow-download.

4.3 Analog 4-20 mA (0-20 mA) Communication

The SCC1-CURRENT Sensor Cable converts the sensor's digital signal to a 4...20 mA (0...20 mA) current output. The output scaling and the additional digital (high/low) output of the cable can be configured in the same way as for the SCC1-ANALOG voltage output cable.

For further information please see the SCC1-CURRENT Sensor Cable datasheet, available on www.sensirion.com/liquidflow-download.

4.4 Communication via USB Cable

The Sensirion SCC1-USB Sensor Cable provides an easy to use USB interface for laboratory and desktop use, especially in combination with the USB-RS485 Sensor Viewer software. Additionally, the SCC1-USB is used to configure the outputs of the SCC1-ANALOG and SCC1-CURRENT interface cables.

For further information please see the SCC1-USB Sensor Cable datasheet, available on www.sensirion.com/liquidflow-download.

4.5 Digital Communication via I²C Bus

The SLQ-QT500 liquid flow meter has been designed for use with the SCC1 interface cables. For special applications, direct communication with the flow meter via the standard I²C-interface is possible. The physical interface consists of two bus lines, a data line (SDA) and a clock line (SCL) which need to be connected via pull-up resistors to the bus voltage of the system.

These lines have to be used on 3.3 V level with a recommended clock frequency of 100 kHz. For the detailed specifications of this I²C communication, please refer to specific I²C Application Notes from Sensirion.

5 Fluidic Specification and Connections

Parameter	SLQ-QT500
Fluidic connection	PFA tube, 6.35 mm (1/4") OD, 4.35 mm ID
Pressure drop (at 120 ml/min, IPA, 23°C, with full length PFA tube)	< 2 mbar
Total internal volume (including full length PFA tube)	5 ml

Table 6: Fluidic specifications

5.1 Fluidic Connection Method

Fluidic connection to the SLQ-QT500 is established by directly connecting to the sensor's 1/4" outer diameter (OD) PFA tubing. A variety of suitable fittings, connectors, and unions is available from different suppliers. Most connectors for 1/4" OD plastic tubing will work. The exact type needs to be determined by the user depending on the user's application.

5.2 PFA Connection Tubing

The flow meter has been robustly engineered to ensure the internal PFA to Quartz interface provides a dependable seal without using any additional adhesives or gasket sealing materials. This tightly integrated design prohibits any disassembly without damaging internal components; never disassemble the flow meter or attempt to replace the PFA tubing!

Shortening the PFA tubing by cutting to the desired length is possible. Please consider the following basic guidelines.

IMPORTANT NOTE: Make sure to always leave tubing of sufficient length (depending on the selected type of fitting) before cutting the tube. Cutting the PFA tubing too short will require replacing the flow meter!

Basic guidelines:

- PFA tubing is non-replaceable.
- Use tubing adapters for 6.35 mm (1/4 inch) outer-diameter and 4.35 mm inner-diameter PFA tubing.
- For optimum accuracy, it is recommended to leave the tubing on the inlet at its original length, and to keep it straight. This is most important for low viscosity liquids at high flow rates. See table 5 for more details.
- On the outlet side, the tubing can be cut or bent as needed, without affecting the flow meter's accuracy for flow in the positive direction (normal requirements for handling PFA tubing apply).
- Bending of tubing and mounting orientation has no influence on the repeatability of the flow meter. To maintain the same measurement conditions and benefit from the excellent repeatability of the SLQ-QT500, the position and orientation of the flow meter and its connection tubing should be fixed after installation.
- If the PFA tubing is cut, it must be ensured that sufficient length is left to connect the flow meter to your system.

		Flow rate (µl/s)		
		1000	1500	2000
Kinematic viscosity (mm ² /s)	1.0 (H ₂ O at 23°C)	6 cm	9 cm	12 cm
	2.5 (IPA at 23°C)	3 cm	4 cm	5 cm
	5.0	2 cm	2 cm	3 cm

Table 7: Recommended minimum length of straight inlet tube depending on viscosity and flow rate. **Important!** This table lists the recommended minimum length from a fluidic point of view. A greater length may be required depending on the selected type of fluidic connector.

6 Mechanical Specifications

Parameter	SLQ-QT500
Flow meter body dimensions	59 x 35 x 23.2 mm
Flow meter overall length including PFA tubing	360±10 mm
Total mass	~45 g
Inner diameter sensor tube	4.5 mm
Inner diameter PFA tube	4.35 mm
Outer diameter PFA tube	6.35 mm (1/4 inch)
Protection class	IP54
Maximum recommended operating pressure ⁶	12 bar (175 psi)
Rated burst pressure	30 bar (435 psi)

Table 8: Mechanical specifications and pressure rating

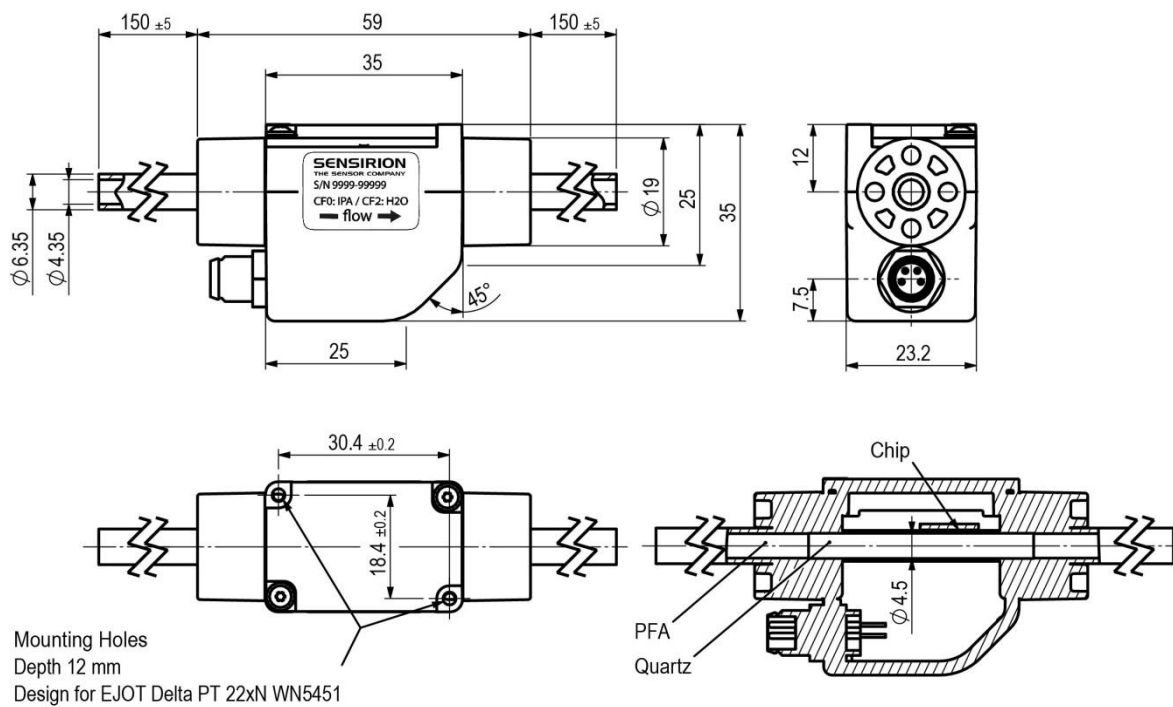

Figure 2: Dimensions of the SLQ-QT500. All dimensions in mm.

⁶ Pressure limited by PFA tubing

6.1 Materials

Part	Material	Flammability
Connection tubing ¼"	PFA	UL-94 V-0
Capillary	Quartz	Not flammable

Table 9: Wetted materials

Part	Material	Flammability
Housing	PPS	UL-94 V-0
Screws and electrical connector	Stainless steel	Not flammable
Cables	Copper	Not flammable
	ETFE	UL-94 V-0

Table 10: Non-wetted materials

6.2 Labels

The SLQ-QT500 has two labels on opposite sides of the housing. Both labels are solvent resistant and contain the following information

- Sensirion product name
- Calibrations on the flow meter: calibration field (CF), type of liquid (H₂O or IPA), full scale flow rate
- Serial number as text and encoded in 2D bar code
- Positive flow direction marked by arrow



Figure 3: Labels on SLQ-QT500

7 Cleanliness of Flow Path

7.1 Particles

The flow path of each SLQ-QT500 flow meter is flushed with ultra-pure water as a final production step before packing. The flow meter is then sealed in PE film under ISO 5 clean room conditions. The particle count limit for the flushing process is less than one detected particle per 1 ml of water, and the detection limit for particles is 100 nm in diameter.

Please contact Sensirion for general customer instructions on cleaning and clean handling of the flow meter.

8 Ordering Information

For OEM applications, the flow meter can be purchased in larger quantities without any additional parts. For optimum performance, Sensirion recommends using the SLQ-QT500 flow meter in combination with the SCC1 interface cables.

For laboratory use and technology evaluation, the Flow Meter Kit SLQ-QT500 can be ordered.

This laboratory-package contains:

- Liquid Flow Meter SLQ-QT500
- PC Software (Viewer & Data Export Tool);
- SCC1-USB 2m Sensor Cable with USB connector for plug-and-play connection to a PC
- SCC1-Analog 2m Sensor Cable with 0-10 V voltage output.

Product	Article Number
SLQ-QT500 Liquid Flow Meter	1-100963-01
Flow Meter Kit SLQ-QT500	1-101004-01

Interface Cables:

SCC1-RS485 2m Sensor Cable Pigtail	1-100804-01
SCC1-RS485 5m Sensor Cable Pigtail	1-101122-01
SCC1-ANALOG 2m Sensor Cable Pigtail	1-101072-01
SCC1-ANALOG 10m Sensor Cable Pigtail	1-101219-01
SCC1-CURRENT 5m Sensor Cable Pigtail	1-101667-01
SCC1-USB Sensor Cable 2m	1-101007-01

Table 11: Ordering information

9 CE, REACH, RoHS, and WEEE

The SLQ-QT500 complies with requirements of the following directives and regulations:



- The device complies with norm EN 50081-2 (Emission Test Series), EN 50082-2 (Immunity Test Series) and ESD protection when used in combination with the SCC1-RS485, SCC1-ANALOG, or SCC1-CURRENT Sensor Cables.
- EU Directive 1907/2006/EC concerning Registration, Evaluation, Authorization and Restriction of Chemicals (**REACH**)
- EU Directive 2002/65/EC on the restriction of certain hazardous substances in electric and electronic equipment (**RoHS**), OJ01.01.2011
- EU Directive 2002/96/EC on waste electrical and electronic equipment (**WEEE**), OJ13.02.2003; esp. its Article 6 (1) with Annex II.
-

10 Important Notices

10.1 Warning, Personal Injury

Do not use this product as safety or emergency stop devices or in any other application where failure of the product could result in personal injury. Do not use this product for applications other than its intended and authorized use. Before installing, handling, using or servicing this product, please consult the data sheet and application notes. Failure to comply with these instructions could result in death or serious injury.

If the Buyer shall purchase or use SENSIRION products for any unintended or unauthorized application, Buyer shall defend, indemnify and hold harmless SENSIRION and its officers, employees, subsidiaries, affiliates and distributors against all claims, costs, damages and expenses, and reasonable attorney fees arising out of, directly or indirectly, any claim of personal injury or death associated with such unintended or unauthorized use, even if SENSIRION shall be allegedly negligent with respect to the design or the manufacture of the product.

10.2 ESD Precautions

The inherent design of this component causes it to be sensitive to electrostatic discharge (ESD). To prevent ESD-induced damage and/or degradation, take customary and statutory ESD precautions when handling this product.

10.3 Warranty

SENSIRION warrants solely to the original purchaser of this product for a period of 12 months (one year) from the date of delivery that this product shall be of the quality, material and workmanship defined in SENSIRION's published specifications of the product. Within such period, if proven to be defective, SENSIRION shall repair and/or replace this product, in SENSIRION's discretion, free of charge to the Buyer, provided that:

- notice in writing describing the defects shall be given to SENSIRION within fourteen (14) days after their appearance;
- such defects shall be found, to SENSIRION's reasonable satisfaction, to have arisen from SENSIRION's faulty design, material, or workmanship;
- the defective product shall be returned to SENSIRION's factory at the Buyer's expense; and
- the warranty period for any repaired or replaced product shall be limited to the unexpired portion of the original period.

This warranty does not apply to any equipment which has not been installed and used within the specifications recommended by SENSIRION for the intended and proper use of the equipment. EXCEPT FOR THE WARRANTIES EXPRESSLY SET FORTH HEREIN, SENSIRION MAKES NO WARRANTIES, EITHER EXPRESS OR IMPLIED, WITH RESPECT TO THE PRODUCT. ANY AND ALL WARRANTIES, INCLUDING WITHOUT LIMITATION, WARRANTIES OF MERCHANTABILITY OR FITNESS FOR A PARTICULAR PURPOSE, ARE EXPRESSLY EXCLUDED AND DECLINED.

SENSIRION is only liable for defects of this product arising under the conditions of operation provided for in the data sheet and proper use of the goods. SENSIRION explicitly disclaims all warranties, express or implied, for any period during which the goods are operated or stored not in accordance with the technical specifications.

SENSIRION does not assume any liability arising out of any application or use of any product or circuit and specifically disclaims any and all liability, including without limitation consequential or incidental damages. All operating parameters, including without limitation recommended parameters, must be validated for each customer's applications by customer's technical experts. Recommended parameters can and do vary in different applications.

SENSIRION reserves the right, without further notice, (i) to change the product specifications and/or the information in this document and (ii) to improve reliability, functions and design of this product.

Copyright© 2018, by SENSIRION.
CMOSens® is a trademark of Sensirion
All rights reserved

11 Headquarters and Subsidiaries

Sensirion AG

Laubisruetistr. 50
CH-8712 Staefa ZH
Switzerland

phone: +41 44 306 40 00

fax: +41 44 306 40 30

info@sensirion.com

www.sensirion.com

Sensirion Taiwan Co. Ltd

phone: +886 3 5506701

info@sensirion.com

www.sensirion.com

Sensirion Inc., USA

phone: +1 312 690 5858

info-us@sensirion.com

www.sensirion.com

Sensirion Japan Co. Ltd.

phone: +81 3 3444 4940

info-jp@sensirion.com

www.sensirion.co.jp

Sensirion Korea Co. Ltd.

phone: +82 31 337 7700~3

info-kr@sensirion.com

www.sensirion.co.kr

Sensirion China Co. Ltd.

phone: +86 755 8252 1501

info-cn@sensirion.com

www.sensirion.com.cn

To find your local representative, please visit www.sensirion.com/distributors

Revision History of the SLQ-QT500 Datasheet

Revision	Date	Changes	
		Chapter	Description
4	July 2018	all	Editorial changes to match new datasheet layout