

# Si4692 Data Short

## High-Performance Digital Radio Baseband Processor with Seamless Blending

The Si469x dual DAB/DAB+ radio co-processor provides significant advances in size, power consumption, and performance to enable DAB/DAB+ Radio reception with DAB-DAB-FM seamless blending in automotive infotainment systems and car radios. It is designed to work with the high-performance automotive Si479x family of radio tuners.

### Applications

- OEM automotive infotainment systems
- Aftermarket car radio systems

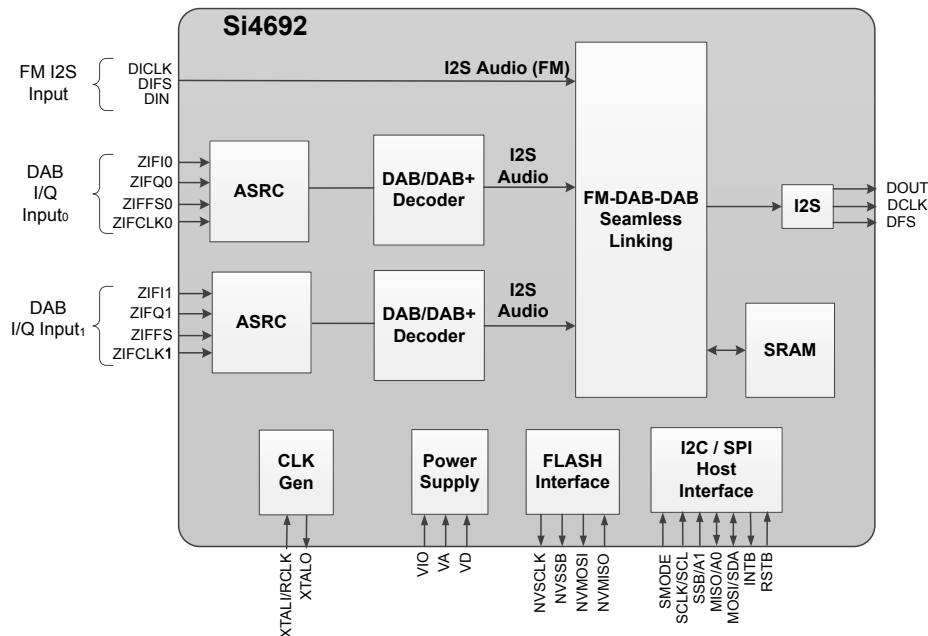

### KEY FEATURES

- Dual DAB/DAB+ co-processor (Si4692)
- Single DAB/DAB+ co-processor (Si4690)
- Integrated DAB/DAB/FM (Si4692) and DAB/FM (Si4690) time and level alignment and seamless blending
  - PAD/XPAD outputs available
- FIC decoder
  - Ensemble info
  - Service list
  - Component info
  - Service linking info
- Full support for data services
  - Packet mode
  - Packet mode with Data Groups
  - Enhanced Packet mode
  - MOT, TPEG packet outputs
- No external RAM required for channel decoding or seamless blending
- Flash memory interface for application program load
- Support for Si479xx Zero-IF DAB I/Q at 2.048 MS/s
- Support for I2S audio from third tuner
- Integrated crystal oscillator
- Reference clock input
- SPI, I2C control interfaces
- LGA 72-pin, 10 x 10 x 1 mm
- Pb-free/RoHS compliant
- AEC-Q100 qualified

# 1. Pin Descriptions

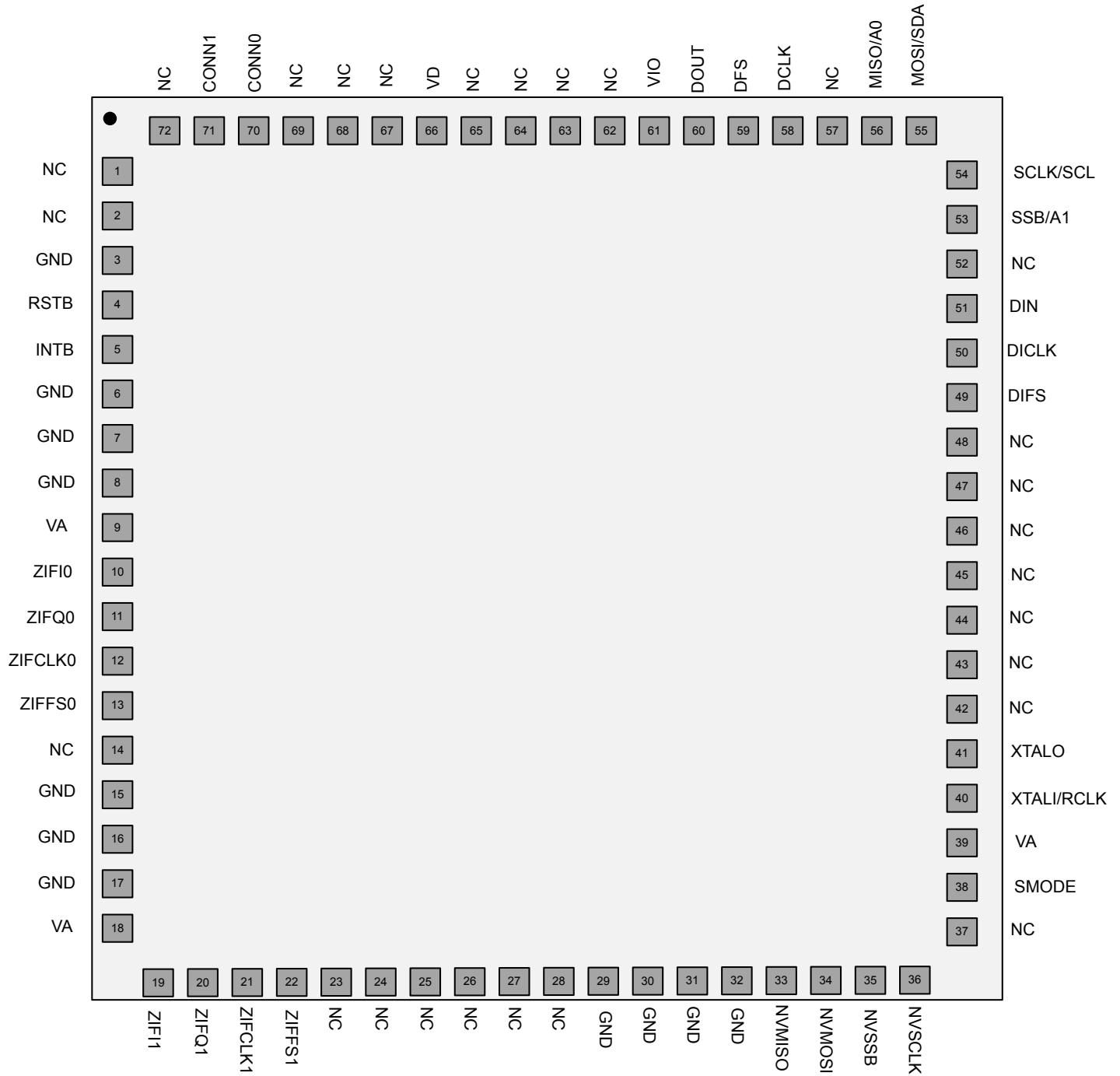

Figure 1.1. Si4692 Pinout Diagram

## 2. Package Outline

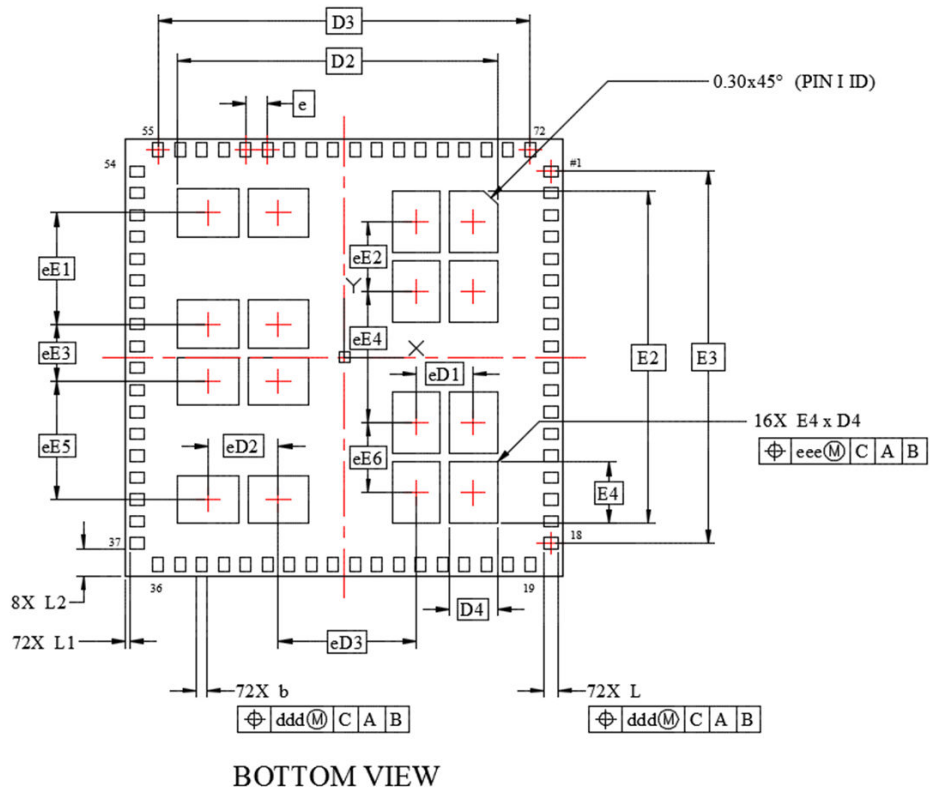
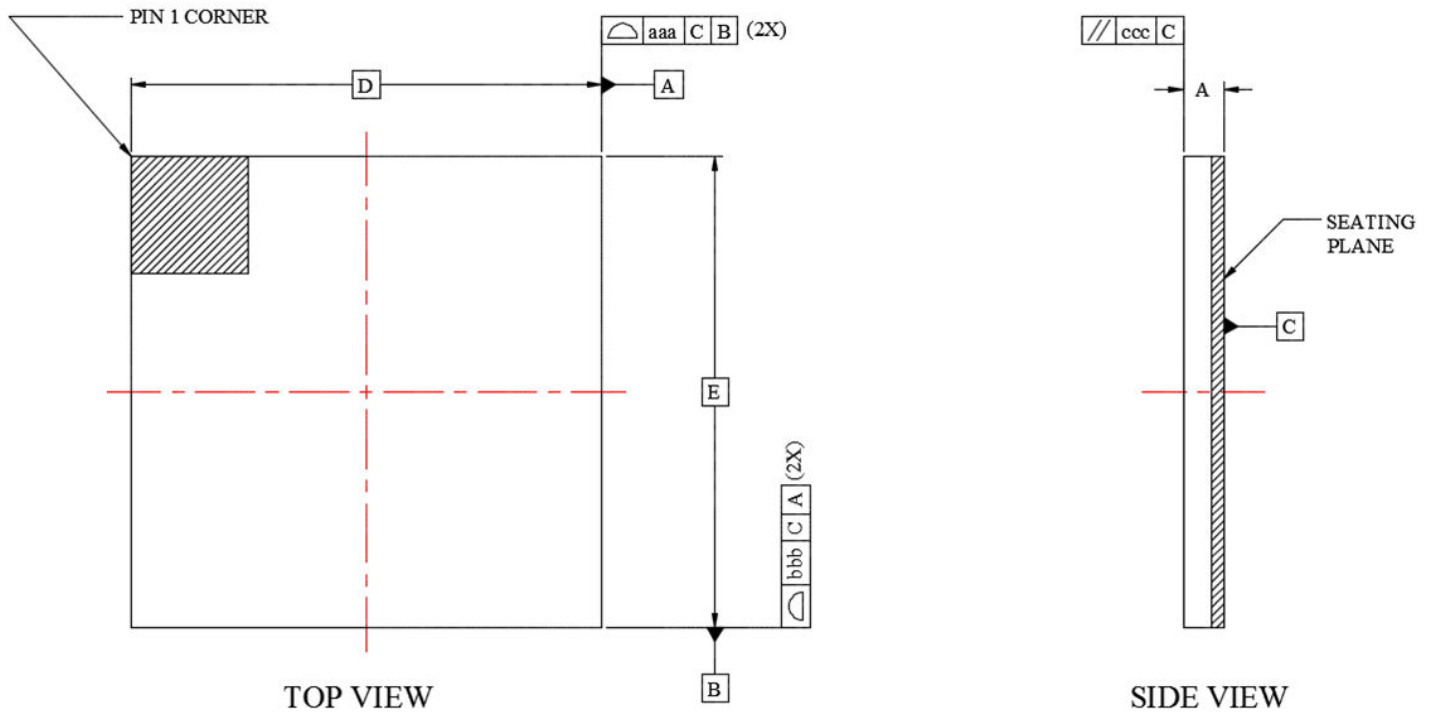

Figure 2.2. 10 x 10 mm 72-Pin LGA

Table 2.1. Package Dimensions

Dimension	Min	Nom	Max
A	1.00	1.08	1.20
b	0.15	0.25	0.35
D	10.0 BSC		
D2	7.20	7.30	7.40
D3	8.50 BSC		
D4	1.00	1.10	1.20
e	0.50 BSC		
E	10.0 BSC		
E2	7.50	7.60	7.70
E3	8.50 BSC		
E4	1.30	1.40	1.50
L	0.225	0.325	0.425
L1	0.05	0.10	0.15
L2	0.575	0.625	0.675
eD1	1.30 BSC		
eD2	1.60 BSC		
eD3	3.15 BSC		
eE1	2.55 BSC		
eE2	1.60 BSC		
eE3	1.30 BSC		
eE4	3.00 BSC		
eE5	2.70 BSC		
eE6	1.60 BSC		
aaa	0.10		
bbb	0.10		
ccc	0.10		
ddd	0.10		
eee	0.10		

**Note:**

1. All dimensions shown are in millimeters (mm) unless otherwise noted.
2. Dimensioning and Tolerancing per ANSI Y14.5M-1994.
3. This drawing conforms to the JEDEC Solid State Outline MO-220.
4. Recommended card reflow profile is per the JEDEC/IPC J-STD-020 specification for Small Body Components.



Smart.  
Connected.  
Energy-Friendly.



**Products**  
[www.silabs.com/products](http://www.silabs.com/products)



**Quality**  
[www.silabs.com/quality](http://www.silabs.com/quality)



**Support and Community**  
[community.silabs.com](http://community.silabs.com)

**Disclaimer**  
Silicon Labs intends to provide customers with the latest, accurate, and in-depth documentation of all peripherals and modules available for system and software implementers using or intending to use the Silicon Labs products. Characterization data, available modules and peripherals, memory sizes and memory addresses refer to each specific device, and "Typical" parameters provided can and do vary in different applications. Application examples described herein are for illustrative purposes only. Silicon Labs reserves the right to make changes without further notice and limitation to product information, specifications, and descriptions herein, and does not give warranties as to the accuracy or completeness of the included information. Silicon Labs shall have no liability for the consequences of use of the information supplied herein. This document does not imply or express copyright licenses granted hereunder to design or fabricate any integrated circuits. The products are not designed or authorized to be used within any Life Support System without the specific written consent of Silicon Labs. A "Life Support System" is any product or system intended to support or sustain life and/or health, which, if it fails, can be reasonably expected to result in significant personal injury or death. Silicon Labs products are not designed or authorized for military applications. Silicon Labs products shall under no circumstances be used in weapons of mass destruction including (but not limited to) nuclear, biological or chemical weapons, or missiles capable of delivering such weapons.

**Trademark Information**

Silicon Laboratories Inc.®, Silicon Laboratories®, Silicon Labs®, SiLabs® and the Silicon Labs logo®, Bluegiga®, Bluegiga Logo®, Clockbuilder®, CMEMS®, DSPLL®, EFM®, EFM32®, EFR®, Ember®, Energy Micro, Energy Micro logo and combinations thereof, "the world's most energy friendly microcontrollers", Ember®, EZLink®, EZRadio®, EZRadioPRO®, Gecko®, ISOModem®, Micrium, Precision32®, ProSLIC®, Simplicity Studio®, SiPHY®, Telegesis, the Telegesis Logo®, USBXpress®, Zentri and others are trademarks or registered trademarks of Silicon Labs. ARM, CORTEX, Cortex-M3 and THUMB are trademarks or registered trademarks of ARM Holdings. Keil is a registered trademark of ARM Limited. All other products or brand names mentioned herein are trademarks of their respective holders.



Silicon Laboratories Inc.  
400 West Cesar Chavez  
Austin, TX 78701  
USA

<http://www.silabs.com>