



3.2Gbps, Low-Power, Compact, SFP Laser Driver

General Description

The MAX3736 is a compact, +3.3V multirate laser driver for SFP/SFF applications up to 3.2Gbps. The device accepts differential data and provides bias and modulation currents for driving a laser. DC-coupling to the laser allows for multirate applications, and reduces the number of external components.

The wide 5mA to 60mA (85mA AC-coupled) modulation current range and 1mA to 100mA bias current make the MAX3736 ideal for driving FP/DFB laser diodes in fiber-optic modules. The laser current setting can be controlled by a current DAC, a voltage DAC, or a resistor. Very low power dissipation, small package size, and reduced component count, make this part an ideal solution for SFP-module applications.

The MAX3736 is available in a small 3mm x 3mm, 16-pin thin QFN package. It operates over a -40°C to +85°C temperature range.

Applications

Gigabit Ethernet SFP/SFF Transceiver Modules
 1G/2G Fibre-Channel SFP/SFF Transceiver Modules
 Multirate OC-3 to OC-48 FEC SFP/SFF Transceiver Modules
 10G Ethernet LX-4 Modules

Features

- ◆ Fully Compatible with SFP and SFF-8472 Specifications
- ◆ Programmable Modulation Current from 5mA to 60mA (DC-Coupled)
- ◆ Programmable Modulation Current from 5mA to 85mA (AC-Coupled)
- ◆ Programmable Bias Current from 1mA to 100mA
- ◆ 56ps Edge Transition Times
- ◆ 22mA (typ) Power-Supply Current
- ◆ Multirate Operation Up to 3.2Gbps
- ◆ On-Chip Pullup Resistor for DIS
- ◆ 16-Pin, 3mm × 3mm Thin QFN Package

Ordering Information

PART	TEMP RANGE	PIN-PACKAGE
MAX3736ETE	-40°C to +85°C	16 Thin QFN-EP*
MAX3736ETE+	-40°C to +85°C	16 Thin QFN-EP*

+ Denotes a lead(Pb)-free/RoHS-compliant package.

*EP = Exposed pad.

Pin Configuration appears at end of data sheet.

Typical Application Circuit

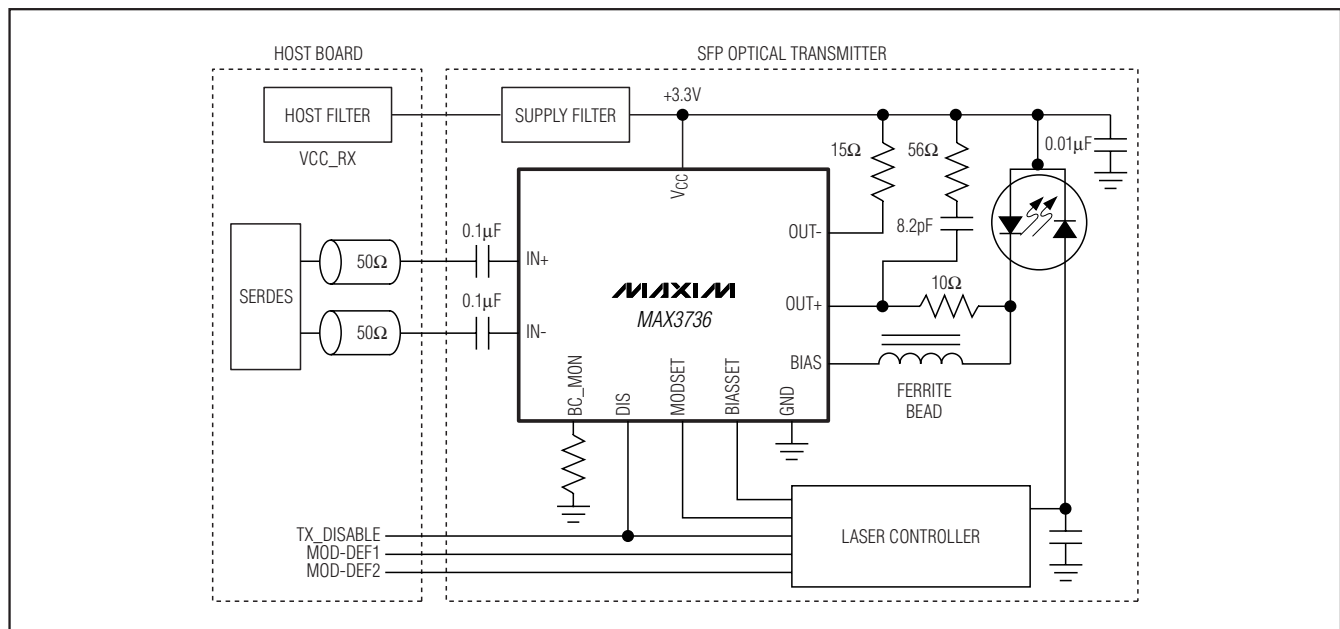

3.2Gbps, Low-Power, Compact, SFP Laser Driver

ABSOLUTE MAXIMUM RATINGS

Power-Supply Voltage V_{CC}	-0.5V to +6.0V
Voltage at IN+, IN-, DIS	-0.5V to ($V_{CC} + 0.5V$)
Voltage at BC_MON, MODSET, BIASSET	-0.5V to +3.0V
Voltage at OUT+, OUT-	+0.5V to ($V_{CC} + 1.5V$)
Voltage at BIAS	+0.5V to ($V_{CC} + 0.5V$)
Current into BIAS, OUT+, OUT-	-20mA to +150mA
Current into IN+, IN-	-20mA to +20mA
Continuous Power Dissipation ($T_A = +85^\circ\text{C}$)	
16-Pin Thin QFN (derate 25mW/°C above +85°C)	2W

Operating Junction Temperature Range	-55°C to +150°C
Storage Temperature Range	-55°C to +150°C
Die Attach Temperature	+400°C
Lead Temperature (soldering, 10s)	+300°C
Soldering Temperature (reflow)	
Lead(Pb)-free	+260°C
Containing lead(Pb)	+240°C

Stresses beyond those listed under "Absolute Maximum Ratings" may cause permanent damage to the device. These are stress ratings only, and functional operation of the device at these or any other conditions beyond those indicated in the operational sections of the specifications is not implied. Exposure to absolute maximum rating conditions for extended periods may affect device reliability.

ELECTRICAL CHARACTERISTICS

($V_{CC} = +2.97V$ to $+3.63V$, $T_A = -40^\circ\text{C}$ to $+85^\circ\text{C}$. Typical values are at $V_{CC} = +3.3V$, $I_{BIAS} = 20\text{mA}$, $I_{MOD} = 30\text{mA}$, $T_A = +25^\circ\text{C}$, unless otherwise noted.) (Note 1)

PARAMETER	SYMBOL	CONDITIONS	MIN	TYP	MAX	UNITS	
Power-Supply Current	I_{CC}	Excludes the laser bias and modulation currents (Note 2)		22	35	mA	
I/O SPECIFICATIONS							
Differential Input Voltage	V_{ID}	$V_{ID} = V_{IN+} - V_{IN-}$, Figure 1	0.2		2.4	V_{P-P}	
Common-Mode Input Voltage	V_{INCM}			$0.6 \times V_{CC}$		V	
Differential Input Resistance	R_{IN}		85	100	115	Ω	
DIS Input Pullup Resistance	R_{PULL}		4.7	7.2	10.0	k Ω	
DIS Input Current		$V_{DIS} = V_{CC}$			15	μA	
		$V_{DIS} = V_{GND}$, $V_{CC} = 3.3V$, $R_{PULL} = 7.4k\Omega$			-450		
DIS Input High Voltage	V_{IH}		2.0			V	
DIS Input Low Voltage	V_{IL}				0.8	V	
BIAS GENERATOR							
Bias Current Range	I_{BIAS}	Current into BIAS pin	1		100	mA	
Bias Off-Current	$I_{BIASOFF}$	Current into BIAS pin, DIS asserted high			100	μA	
BIASSET Current Gain	G_{BIAS}	(Note 3)	$5\text{mA} \leq I_{BIAS} \leq 10\text{mA}$	70	85	95	A/A
			$10\text{mA} \leq I_{BIAS} \leq 100\text{mA}$	79	85	91	
BIASSET Current Gain Stability		$10\text{mA} \leq I_{BIAS} \leq 100\text{mA}$ (Note 4)	-4.4		+4	%	
BIASSET Current Gain Linearity		$10\text{mA} \leq I_{BIAS} \leq 100\text{mA}$ (Note 5)	-2.3		+2.3	%	
Bias Overshoot		During SFP module hot plugging; see Figure 3 (Notes 5, 6)			10	%	
Bias-Current Monitor Gain		(Note 5)		13.7		mA/A	
Bias-Current Monitor Gain Stability (Notes 4, 5)		$1\text{mA} \leq I_{BIAS} \leq 5\text{mA}$		4		%	
			$5\text{mA} \leq I_{BIAS} \leq 10\text{mA}$	-7	2.8		+7
			$10\text{mA} \leq I_{BIAS} \leq 100\text{mA}$	-5	2.4		+5

3.2Gbps, Low-Power, Compact, SFP Laser Driver

MAX3736

ELECTRICAL CHARACTERISTICS (continued)

($V_{CC} = +2.97V$ to $+3.63V$, $T_A = -40^\circ C$ to $+85^\circ C$. Typical values are at $V_{CC} = +3.3V$, $I_{BIAS} = 20mA$, $I_{MOD} = 30mA$, $T_A = +25^\circ C$, unless otherwise noted.) (Note 1)

PARAMETER	SYMBOL	CONDITIONS	MIN	TYP	MAX	UNITS	
Modulation Current Range	I_{MOD}	Current into OUT+, $R_L = 15\Omega$, V_{OUT+} and $V_{OUT-} \geq 0.6V$ (DC-coupled)	5		60	mAp-P	
		Current into OUT+, $R_L = 15\Omega$, V_{OUT+} and $V_{OUT-} \geq 2.0V$ (AC-coupled)	5		85		
MODULATOR							
Modulation Current Gain	G_{MOD}	(Note 3)	$5mA \leq I_{MOD} \leq 10mA$	70	85	95	A/A
			$10mA \leq I_{MOD} \leq 85mA$	79	85	91	
Modulation Current Gain Stability		$10mA \leq I_{MOD} \leq 85mA$ (Notes 4, 5)	-4.4		+4	%	
Modulation Current Gain Linearity		$10mA \leq I_{MOD} \leq 85mA$ (Note 5)	-3.3		+3.3	%	
Bias Current Gain and Modulation Current Gain Matching (Notes 5, 7)			$I_{BIASSET} = 0.15mA$; $I_{MODSET} = 0.7mA$		2.3		%
			$I_{BIASSET} = I_{MODSET} = 0.15mA$		0.1	1.4	
			$I_{BIASSET} = I_{MODSET} = 0.4mA$		0.1	1	
			$I_{BIASSET} = I_{MODSET} = 0.6mA$		0.1	1	
			$I_{BIASSET} = I_{MODSET} = 0.9mA$		0.1	1	
Modulation OFF Current	I_{MODOFF}	DIS asserted high			100	μA	
Rise Time	t_R	20% to 80%; $10mA \leq I_{MOD} \leq 60mA$ (Note 5)		48	80	ps	
Fall Time	t_F	80% to 20%; $10mA \leq I_{MOD} \leq 60mA$ (Note 5)		58	80	ps	
Deterministic Jitter (Notes 5, 8)			$10mA \leq I_{MOD} \leq 60mA$; 2.67Gbps; $2^{23}-1$ PRBS		16	38	pSP-P
			$10mA \leq I_{MOD} \leq 60mA$; 3.2Gbps; K28.5 pattern		17	38	
			$10mA \leq I_{MOD} \leq 60mA$; 155Mbps; $2^{23}-1$ PRBS		30		
			$10mA \leq I_{MOD} \leq 60mA$; 3.2Gbps; K28.5; $T_A = +100^\circ C$		6.3		ps
Random Jitter		$10mA \leq I_{MOD} \leq 60mA$ (Note 5)		0.6	1	pSRMS	

Note 1: Specifications at $-40^\circ C$ are guaranteed by design and characterization.

Note 2: Maximum value is specified at $I_{MOD} = 60mA$ and $I_{BIAS} = 100mA$. BC_MON connected to V_{CC} .

Note 3: Modulation current gain, G_{MOD} , is defined as $G_{MOD} = I_{MOD} / I_{MODSET}$. Bias current gain, G_{BIAS} , is defined as $G_{BIAS} = I_{BIAS} / I_{BIASSET}$. The nominal gain is measured at $V_{CC} = +3.3V$ and $T_A = +25^\circ C$.

Note 4: Gain stability is defined as $[(Gain) - (Nom_Gain)] / (Nom_Gain)$ over the listed current range, temperature, and supply variation. Nominal gain is measured at $V_{CC} = +3.3V$, $T_A = +25^\circ C$. The voltage at the BC_MON pin must not exceed 1.39V.

Note 5: Guaranteed by design and characterization; see Figure 2.

Note 6: V_{CC} turn-on time must be less than 0.8s, DC-coupled interface.

Note 7: The gain matching is defined as $ABS [(G_{MOD}/G_{BIAS} - G_{MODNOM}/G_{BIASNOM}) / (G_{MODNOM}/G_{BIASNOM})]$ over the specified temperature and voltage supply range.

Note 8: For supply noise tolerance, noise is added to the supply (100mVp-p) up to 2MHz; see Figure 3.

3.2Gbps, Low-Power, Compact, SFP Laser Driver

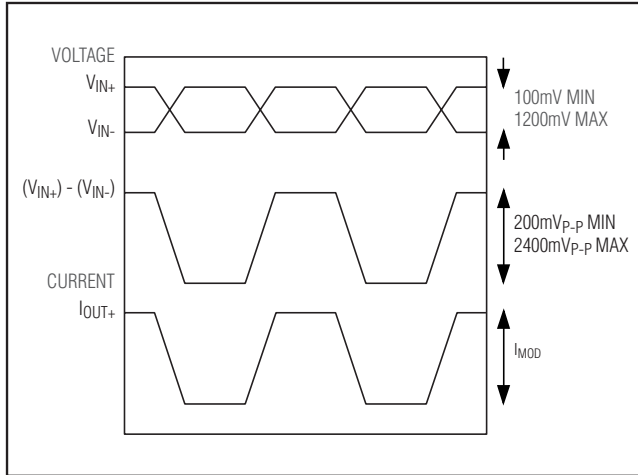

Figure 1. Definition of Single-Ended Input Voltage Range

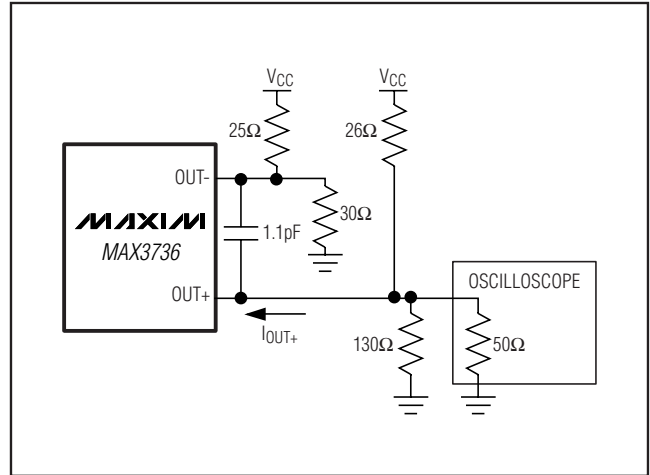

Figure 2. Output Termination for Characterization

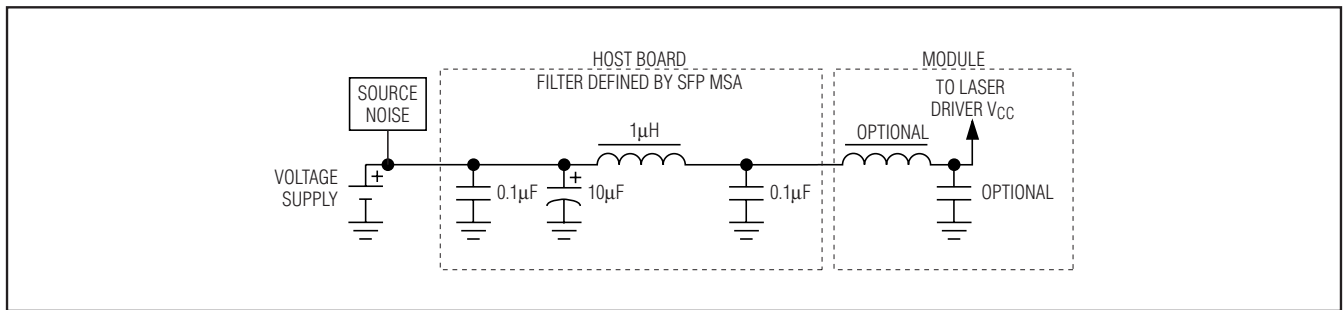
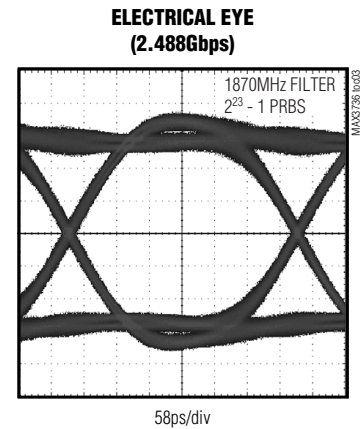
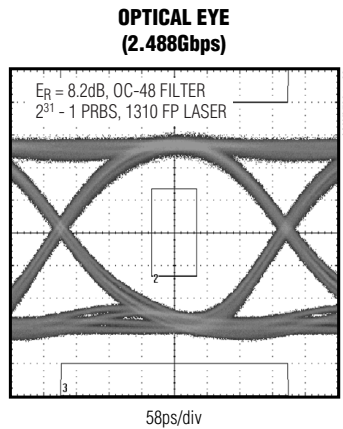
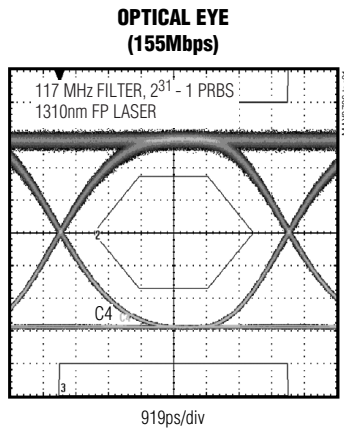

Figure 3. Supply Filter

Typical Operating Characteristics

(Typical values are at $V_{CC} = 3.3V$, $I_{BIAS} = 20mA$, $I_{MOD} = 30mA$, $T_A = +25^\circ C$, unless otherwise noted.)



3.2Gbps, Low-Power, Compact, SFP Laser Driver

MAX3736

Typical Operating Characteristics (continued)

(Typical values are at $V_{CC} = 3.3V$, $I_{BIAS} = 20mA$, $I_{MOD} = 30mA$, $T_A = +25^\circ C$, unless otherwise noted.)

SUPPLY CURRENT vs. TEMPERATURE

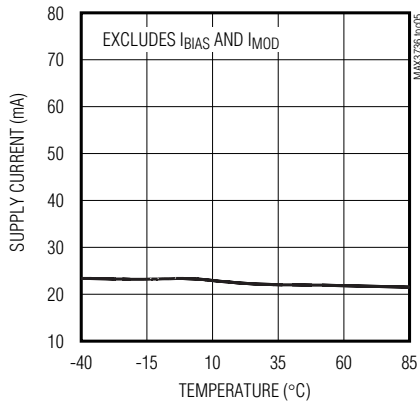

BIAS CURRENT MONITOR GAIN vs. TEMPERATURE

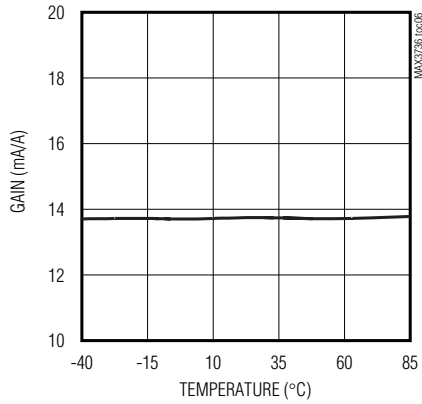

MODULATION CURRENT vs. MODSET RESISTANCE ($Z_L = 15\Omega$)

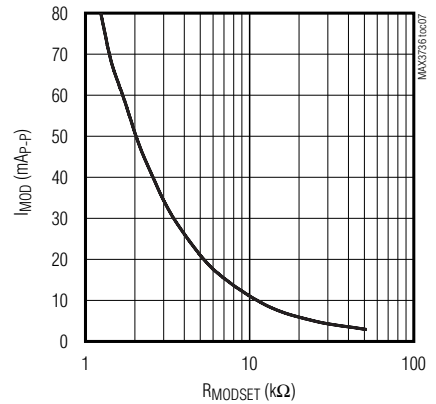

BIAS CURRENT vs. BIAS RESISTANCE

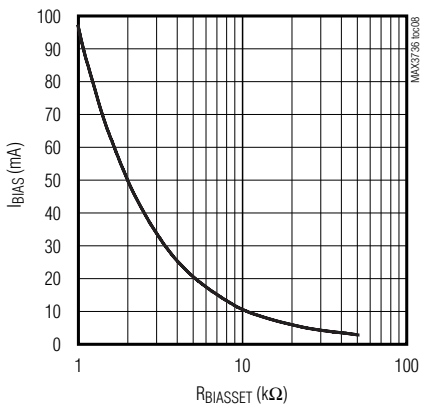

EDGE TRANSITION TIME vs. MODULATION AMPLITUDE

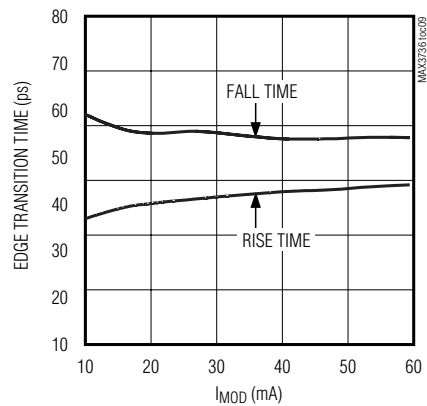

3.2Gbps, Low-Power, Compact, SFP Laser Driver

Typical Operating Characteristics (continued)

(Typical values are at $V_{CC} = 3.3V$, $I_{BIAS} = 20mA$, $I_{MOD} = 30mA$, $T_A = +25^\circ C$, unless otherwise noted.)

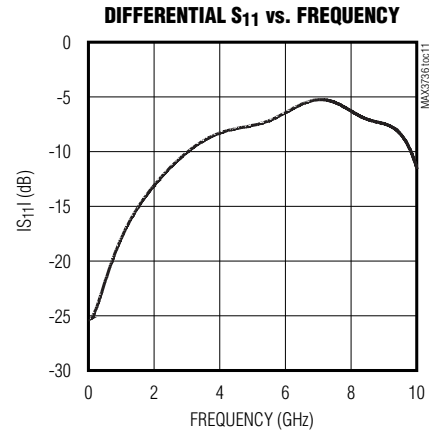
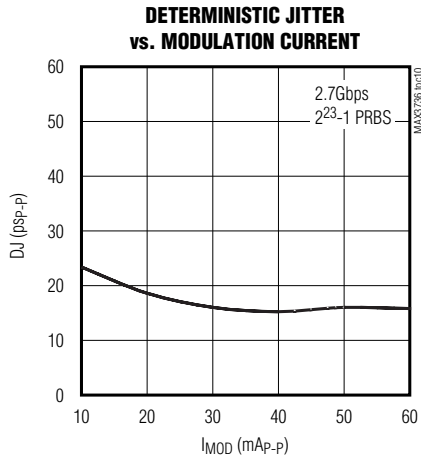

Pin Description

PIN	NAME	FUNCTION
1, 4, 9, 12, 15	VCC	+3.3V Supply Voltage. All pins must be connected to VCC.
2	IN+	Noninverted Data Input
3	IN-	Inverted Data Input
5	BIASSET	A current DAC, a voltage DAC, or a resistor, connected from this pin to ground, sets the desired bias current for the laser (see the <i>Programming the Laser Bias Current</i> section).
6	MODSET	A current DAC, a voltage DAC, or a resistor, connected from this pin to ground, sets the desired bias current for the laser (see the <i>Programming the Laser Modulation Current</i> section).
7	BC_MON	Bias Current Monitor Output. Current out of this pin develops a ground-referenced voltage across an external resistor that is proportional to the bias current.
8	BIAS	Laser Bias Current Output
10	OUT+	Noninverted Modulation Current Output. I_{MOD} flows into this pin when input data is high.
11	OUT-	Inverted Modulation Current Output. I_{MOD} flows into this pin when input data is low.
13, 14	GND	Ground
16	DIS	Transmitter Disable, TTL. Laser output is disabled when DIS is asserted high or left unconnected. The laser output is enabled when this pin is asserted low.
—	EP	Exposed Pad. Must be soldered to the circuit board ground for proper thermal and electrical performance (see the <i>Exposed-Pad Package</i> section).

3.2Gbps, Low-Power, Compact, SFP Laser Driver

MAX3736

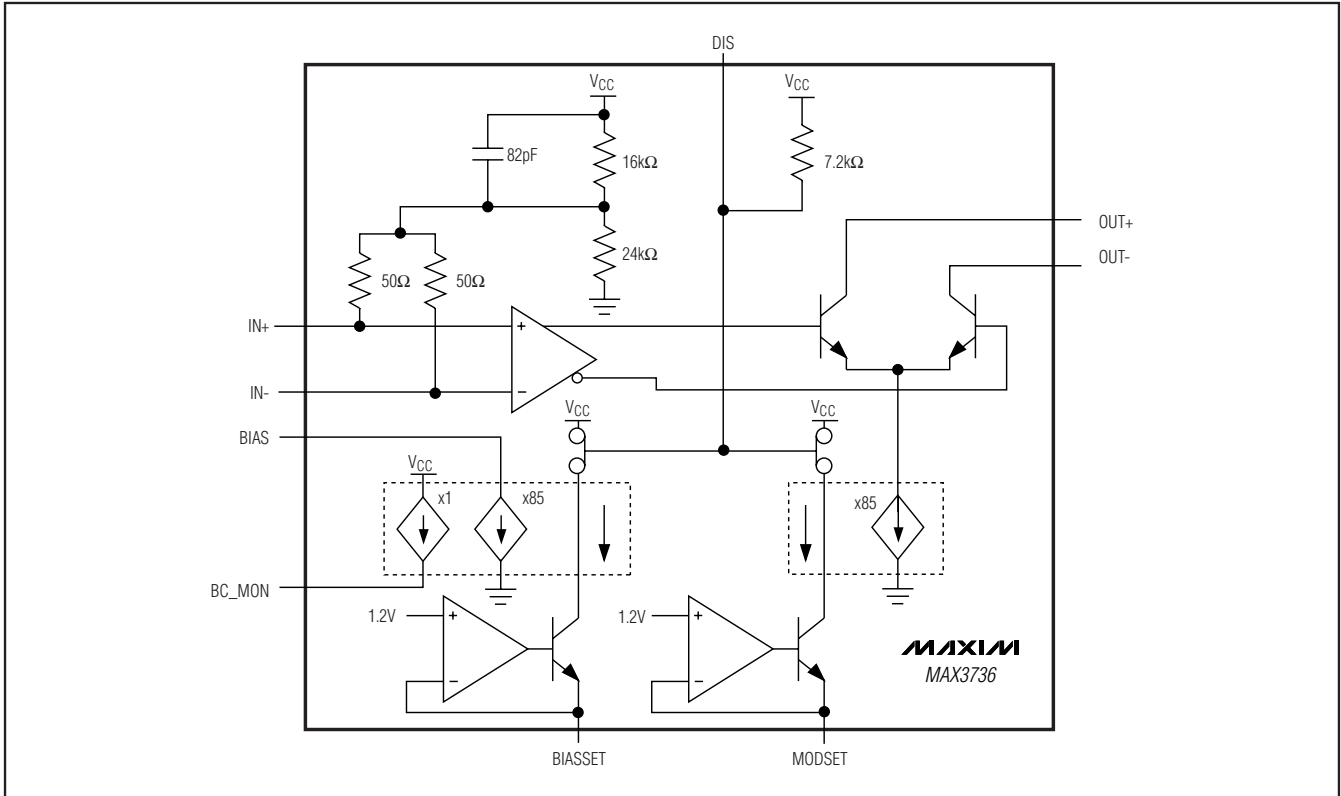

Figure 4. Functional Diagram

Detailed Description

The MAX3736 laser driver consists of three operational blocks: a bias current generator, a modulation current generator, and a high-speed modulation path. The laser-biasing block includes a monitor output for bias-sensing purposes. Both the bias and modulation generating blocks are enabled and disabled by the DIS pin. The high-speed modulation path provides a 100Ω differential input resistance.

Bias Current Generator

To maintain constant average optical power, the MAX3736 is designed to interface to a laser controller IC. The laser controller IC controls the MAX3736, and maintains a constant laser power using an automatic power-control (APC) circuit. A back-facet photodiode, mounted in the laser package, is used to convert the optical power into a photocurrent. The laser controller IC adjusts the laser bias current so the monitor photodiode's current matches the level programmed by the user. It does this by adjusting the current sourced by the MAX3736's BIASSET pin. The MAX3736 reacts by increasing or decreasing the laser current at BIAS.

Bias Current Monitor

The MAX3736 features a bias current monitor (BC_MON). This monitor is realized by mirroring a fraction of the bias current and developing a voltage across an external resistor connected to ground. For example, connecting a 100Ω resistor to ground gives the following relationship:

$V_{BC_MON} = (I_{BIAS} / 73) \times 100\Omega$. For compliance, the voltage on BC_MON must be kept below 1.39V.

Modulation Current Generator

The laser's modulation amplitude can be controlled by placing a resistor from MODSET to ground. To set the modulation amplitude, see the I_{MOD} vs. R_{MODSET} graph in the *Typical Operating Characteristics*. A more advanced control scheme employs the use of a laser controller IC to control modulation current to stabilize the extinction ratio. For more information on controlling the extinction ratio, refer to Application Note 1092: *HFAN-02.3.1: Maintaining Average Power and Extinction Ratio, Part 1, Slope Efficiency and Threshold Current*.

3.2Gbps, Low-Power, Compact, SFP Laser Driver

High-Speed Modulation Driver

The output stage is composed of a high-speed differential pair and a programmable modulation current source. The MAX3736 is optimized for driving a 15Ω load; the minimum instantaneous voltage required at OUT+ is 0.6V. Modulation current swings up to 60mA are possible.

To interface with the laser diode, a damping resistor (R_D) is required for impedance matching. The combined resistance of the series damping resistor and the equivalent series resistance of the laser diode should equal 15Ω. To reduce optical output aberrations and duty-cycle distortion caused by laser diode parasitic inductance, an RC shunt network might be necessary. Refer to Application Note 274: *HFAN-02.0: Interfacing Maxim Laser Drivers with Laser Diodes* for more information.

At high data rates, e.g., 2.5Gbps, any capacitive load at the cathode of a laser diode degrades optical output performance. Because the BIAS output is directly connected to the laser cathode, minimize the parasitic capacitance associated with the pin by using an inductor to isolate the BIAS pin parasitics from the laser cathode.

In the absence of input data, the modulation current switches to OUT-, squelching the transceiver output.

Disable

The DIS pin disables the modulation and bias current. The typical enable time is 2μs for bias current and 1μs for modulation current. The typical disable time is 200ns for bias current and 250μs for modulation current. The DIS pin has a 7.4kΩ internal pullup resistor.

Design Procedure

Programming the Modulation Current

There are three methods for setting the modulation current on the MAX3736 laser driver. The current can be set by using a current DAC, a voltage DAC in series with a resistor, or by using a resistor connected to GND.

To program the laser modulation current using a current DAC, attach the DAC to the MODSET pin and set the current using the following equation:

$$I_{\text{MOD}} = I_{\text{MODSET}} \times 85$$

To program the laser modulation current using a voltage DAC, attach the DAC to the MODSET pin through a series resistor, R_{SERIES}, and set the current using the following equation:

$$I_{\text{MOD}} = \frac{1.2\text{V} - V_{\text{DAC}}}{R_{\text{SERIES}}} \times 85$$

To program the laser modulation current using a resistor, place the resistor from MODSET to ground. I_{MOD} current can be calculated by the following equation:

$$I_{\text{MOD}} = \frac{1.2\text{V}}{R_{\text{MODSET}}} \times 85$$

Programming the Bias Current

There are three methods for setting the bias current on the MAX3736 laser driver. The current can be set by using a current DAC, a voltage DAC in series with a resistor, or by using a resistor connected to GND.

To program the laser bias current using a current DAC, attach the DAC to the BIASSET pin and set the current using the following equation:

$$I_{\text{BIAS}} = I_{\text{BIASET}} \times 85$$

To program the laser bias current using a voltage DAC, attach the DAC to the BIASSET pin through a series resistor, R_{SERIES}, and set the current using the following equation:

$$I_{\text{BIAS}} = \frac{1.2\text{V} - V_{\text{DAC}}}{R_{\text{SERIES}}} \times 85$$

To program the laser bias current using a resistor, place the resistor from BIASSET to ground. I_{BIAS} current can be calculated by the following equation:

$$I_{\text{BIAS}} = \frac{1.2\text{V}}{R_{\text{BIASET}}} \times 85$$

3.2Gbps, Low-Power, Compact, SFP Laser Driver

MAX3736

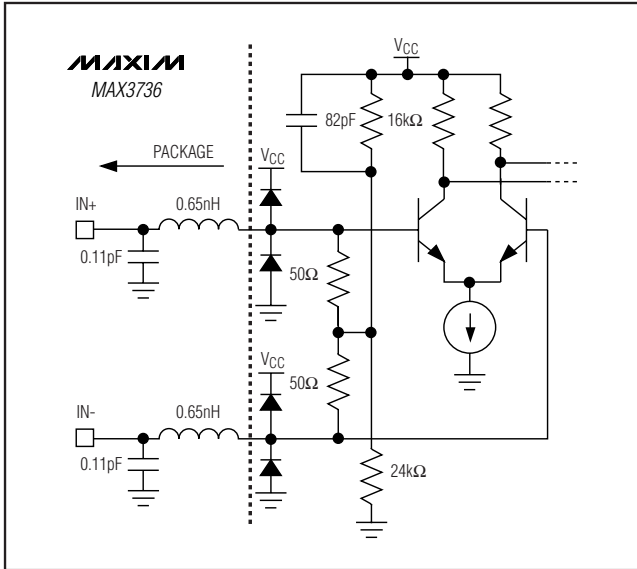

Figure 5. Simplified Input Circuit Schematic

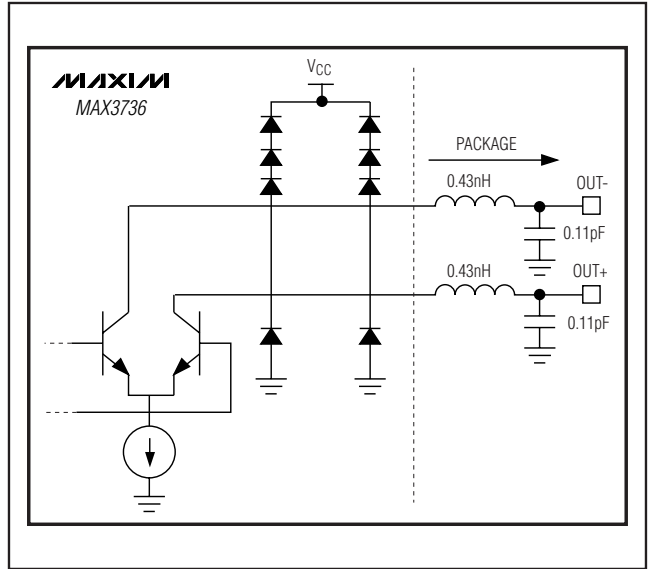

Figure 6. Simplified Output Circuit Schematic

Input Termination Requirements

The MAX3736 data inputs are SFP MSA compliant. On-chip 100Ω, differential input impedance is provided for optimal termination (Figure 5). Because of the on-chip biasing network, the MAX3736 inputs self-bias to the proper operating point to accommodate AC-coupling.

Applications Information

Data Input Logic Levels

The MAX3736 is directly compatible with +3.3V reference CML. Either DC or AC-coupling can be used for CML referenced to +3.3V. For all other logic types, AC-coupling should be used. DC coupling to CML is fine, but it negates the squelching function on the modulation path.

Modulation Currents Exceeding 60mA

For applications requiring a modulation current greater than 60mA, headroom is insufficient for proper operation of the laser driver if the laser is DC-coupled. To avoid this problem, the MAX3736 modulation output can be AC-coupled to the cathode of a laser diode. An external pullup inductor is necessary to DC-bias the modulation output at VCC. Such a configuration isolates laser forward voltage from the output circuitry and allows the output at OUT+ to swing above and below the supply

voltage (VCC). When AC-coupled, the MAX3736 modulation current can be programmed from 5mA to 85mA. Refer to Maxim Application Note *HFAN 02.0: Interfacing Maxim's Laser Drivers to Laser Diodes* for more information on AC-coupling laser drivers to laser diodes.

Interface Models

Figures 5 and 6 show simplified input and output circuits for the MAX3736 laser driver.

Layout Considerations

To minimize loss and crosstalk, keep the connections between the MAX3736 output and the laser as short as possible. Use good high-frequency layout techniques and multilayer boards with an uninterrupted ground plane to minimize EMI and crosstalk.

Exposed-Pad Package

The exposed pad on the 16-pin QFN provides a very low thermal resistance path for heat removal from the IC. The pad is also electrical ground on the MAX3736 and must be soldered to the circuit board ground for proper thermal and electrical performance. Refer to Application Note 862: *HFAN-08.1: Thermal Considerations of QFN and Other Exposed-Paddle Packages* for additional information.

3.2Gbps, Low-Power, Compact, SFP Laser Driver

Laser Safety and IEC 825

Using the MAX3736 laser driver alone does not ensure that a transmitter design is compliant with IEC 825. The entire transmitter circuit and component selections must be considered. Customers must determine the level of fault tolerance required by their application. Please recognize that Maxim products are not designed or authorized for use as components in systems intended for surgical implant into the body, for applications intended to support or sustain life, or for any other application where the failure of a Maxim product could create a situation where personal injury or death may occur.

Pin Configuration

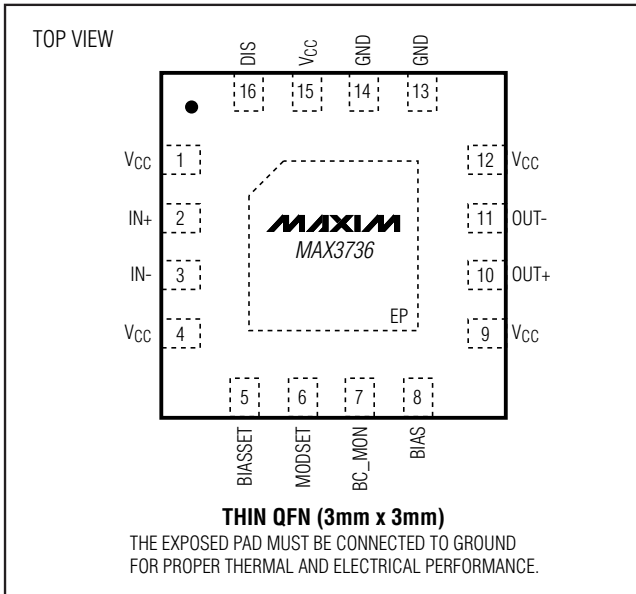

Chip Information

PROCESS: SiGe BiPOLAR

Package Information

For the latest package outline information and land patterns, go to www.maxim-ic.com/packages. Note that a "+", "#", or "-" in the package code indicates RoHS status only. Package drawings may show a different suffix character, but the drawing pertains to the package regardless of RoHS status.

PACKAGE TYPE	PACKAGE CODE	OUTLINE NO.	LAND PATTERN NO.
16 TQFN-EP	T1633-2	21-0136	90-0030

3.2Gbps, Low-Power, Compact, SFP Laser Driver

Revision History

REVISION NUMBER	REVISION DATE	DESCRIPTION	PAGES CHANGED
0	12/03	Initial release	—
1	2/06	Added lead(Pb)-free part to the <i>Ordering Information</i> table	1
2	9/10	Removed the dice package from the <i>Ordering Information</i> table and the <i>Electrical Characteristics</i> table Note 1; removed the <i>Wire-Bonding Die</i> , <i>Chip Topography/Pad Configuration</i> , <i>Chip Topography</i> , and <i>Bonding Coordinates</i> sections and Table 1; added the soldering information for leaded and lead-free packages to the <i>Absolute Maximum Ratings</i> section; added the <i>Package Information</i> table	1, 2, 3, 9, 10, 11

MAX3736

Maxim cannot assume responsibility for use of any circuitry other than circuitry entirely embodied in a Maxim product. No circuit patent licenses are implied. Maxim reserves the right to change the circuitry and specifications without notice at any time.

Maxim Integrated Products, 120 San Gabriel Drive, Sunnyvale, CA 94086 408-737-7600 _____ 11