

# LOW VOLTAGE FTP-608 Series

## 2" HIGH SPEED THERMAL PRINTER

### FTP-628MCL101#72/103#72

### Easy Loading Method

#### ■ OVERVIEW

The FTP-628MCL series is an ultra compact, high speed, low voltage printer mechanism that supports 2" paper width (58mm). The removable platen design simplifies both paper loading and maintenance.

This series can be used for a variety of applications such as portable terminals, POS systems, kiosks, ATM's as well as test and measurement equipment.

#### ■ HIGHLIGHTS

- **Easy loading type**  
Platen removal design simplifies paper loading and maintenance.
- **Ultra compact**  
FTP-628MCL101#72: 15.5 x 70.2 x 33.0 mm (Hx W x D)  
FTP-628MCL103#72: 15.5 x 70.4 x 33.0 mm (Hx W x D)
- **High speed printing**  
Using Fujitsu's unique head drive control, a print speed of 100mm/sec. (800 dotlines/sec.) maximum can be achieved at a 9.5V.
- **High resolution printing**  
8 dots/mm of resolution printing is possible.
- **RoHS compliant**



# FTP-628MCL101#72 / 103#72

## ■ PART NUMBERS

Item	Part number	
Printer mechanism	FTP-628MCL101#72 (2" wide paper: 58mm) without platen detect switch FTP-628MCL103#72 (2" wide paper: 58mm) with platen detect switch	
LSI for driving	FTP-628CU311-R	
Interface board	USB/RS232C	FTP-628DSL311-R, FTP-628MCL312-R*
Interface cables	Serial	FTP-628Y302
	USB	FTP-629Y301#01-R
Power cable	Head, motor, logic	FTP-628Y403

\*: This interface board accepts a 21.6V - 26.4V input

## ■ SPECIFICATIONS

Item	Specifications
Part number	FTP-628MCL101#72 / 103#72
Printing method	Thermal-line dot method
Dot structure	384 dots/line
Dot pitch (Horizontal)	0.125 mm (8 dots/mm)—Dot density
Dot pitch (Vertical)	0.125 mm (8 dots/mm)—Line feed pitch
Effective printing area	48 mm
Number of columns	ANK 32 columns/line (maximum 12x 24 dot font)
Paper width	58 mm +0/-1
Paper thickness	60 to 100 $\mu$ m (some paper in this range may not be used because of paper characteristics)
Printing speed*	Maximum 100mm/sec. (800 dot lines/sec.) at 9.5V Maximum 80mm/sec. (640 dot lines/sec.) at 8.5V
Character types	Alphanumeric, katakana: 159 types International and special characters: 195 types JIS Kanji level 1, level 2, non-Kanji (supported only when Kanji CG is mounted): about 6800 types
Character, dimensions (H×W), number of columns	12 × 24 dots, (1.5 × 3.0mm), 32 columns: ANK 24 × 24 dots, (3.0 × 3.0mm), 16 columns: ANK, Kanji 8 × 16 dots, (1.0 × 2.0 mm), 48 columns: ANK 16 × 16 dots, (2.0 × 2.0 mm), 24 columns: ANK, Kanji

\*: Concurrent applied dots: 64 dots or less at 25°C, batch image print, using standard paper

# FTP-628MCL101#72 / 103#72

## ■ SPECIFICATIONS

Item		Specification
		FTP-628MCL101#72 / 103#72
Interface		Conforms to RS232C / USB
Operating Voltage	For print head	4.2 VDC to 9.5 V, average current 2.4A, at 25°C, Rav=176Ω concurrent applied dots: 64 dots
	or motor	4.2 VDC to 9.5 V, 0.75A maximum (average 0.56A)
	For logic	3.3VDC±10% or 5.5V±10%, 0.1A maximum
Dimensions	Printer mechanism	FTP-628MCL101#72: 70.2 x 33.0 x 15.5 mm (W x D x H) FTP-628MCL103#72: 70.4 x 33.0 x 15.5 mm (W x D x H)
	Interface board	67.2 x 32 x 11.2mm (W x D x H)
Weight	Printer mechanism	Approximately 40g
	Interface board	Approximately 15g
Head life		Pulse resistance: 100 million pulses (under our standard conditions). Abrasion resistance: paper traveling distance 50km (print ratio: 25% or less)
Operating environment	Operating temperature*	0° C to +50° C
	Operating humidity	20 to 85% RH (no condensation)
	Storage temperature	-20° C to +60° C (paper not included)
	Storage humidity	5 to 95% RH (no condensation)
Detection function	Head temperature detection	Detected by thermistor
	Paper out/mark detection	Detected by photo-interrupter
Recommended thermal sensitive paper		High sensitive paper: TF50KS-E4 (Nippon Paper)
		Standard paper: TK60KS-E (Nippon Paper) PD150R (Oji Paper)
		Medium life storage paper: TK60KS-F1 (Nippon Paper) PD170R (Oji Paper) P220VBB-1 (Mitsubishi Paper)
		Long life storage paper: PD160R-N (Oji Paper) AFP-235 (Mitsubishi Paper) TP50KJ-R (Nippon Paper) HA220AA (Nippon Paper)

\*+5°C to +40°C printing density assurance range (-25°C to 70°C capability)

# FTP-628MCL101#72 / 103#72

## ■ INTERFACE BOARD FUNCTION

Item	Item	Item
1. Test print function	6. Motor power saving function	
2. Paper out detection	7. Mark detection function	
3. Paper near end detection	8. MCU operation abnormality detection	
4. Thermal head temperature abnormality detection	9. Platen open detect (valid for FTP-628MCL103#72)	
5. Head voltage abnormality detection		

## ■ DIMENSIONS

### 1. Printer mechanism: 2- inch

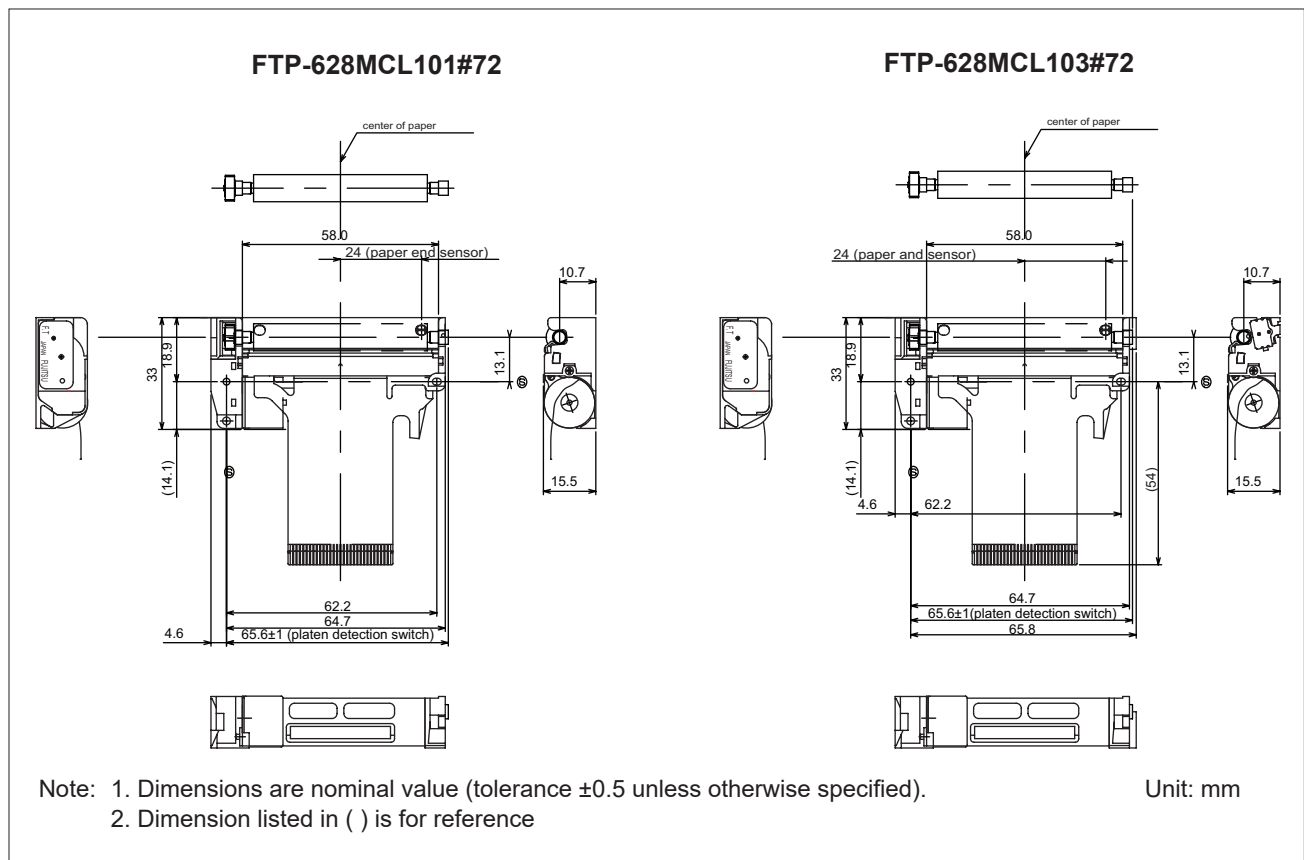

# FTP-628MCL101#72 / 103#72

## ■ PRINTER CONNECTOR (FLEXIBLE PT BOARD) PIN ARRAYS

### FTP-628 MCL101#72 / 103#72

Thermal head, control circuit side connector: 52610-3071Molex or equivalent product

No	Signal	I/O	Contents
1	PHK	O	Cathode for photo interruptor
2	VSEN	I	paper sensor power
3	PHE	O	Emittor for photo interruptor
4	N.C. (101)/ SW1 (103)	-/O	Platen release switc
5	N.C. (101)/ SW2 (103)	-/O	Platen release switch
6	COM		Head drive power
7	COM		
8	SI		Data in
9	CLK	I	Synchronous clock for communication
10	GND	—	Ground power supply for thermal head
11	GND	—	
12	STB6	I	Thermal head energizing control signal
13	STB5	I	
14	STB4	I	
15	VDD	I	Logic power
16	TM	O	Thermally sensitive resistor input termnial 1
17	TM	O	Thermally sensitive resistor input termnial 2
18	STB3	I	Thermal head energizing control signal
19	STB2	I	
20	STB1	I	
21	GND	—	Ground power supply for thermal head
22	GND	—	
23	LAT	I	Data latch
24	SO	O	Data out
25	COM		Power supply for thermal head
26	COM		
27	MT A	I	Stepping motor excitation signal
28	MT $\bar{A}$	I	
29	MT B	I	
30	MT $\bar{B}$	I	

Do not plug or unplug the FPC when power is on.

# FTP-628MCL101#72 / 103#72

---

## Contact

### Japan

FUJITSU COMPONENT LIMITED  
Shinagawa Seaside Park Tower  
12-4, Higashi-shinagawa 4-chome,  
Tokyo 140 0002, Japan  
Tel: (81-3) 3450-1682  
Fax: (81-3) 3474-2385  
Email: fcl-contact@cs.jp.fujitsu.com  
Web: www.fujitsu.com/jp/group/fcl/en/

### North and South America

FUJITSU COMPONENTS AMERICA, INC.  
1230 E. Arques Ave., MS 160  
Sunnyvale, CA 94085 U.S.A.  
Tel: (1-408) 745-4900  
Fax: (1-408) 745-4970  
Email: components@us.fujitsu.com  
Web: http://us.fujitsu.com/components/

### Europe

FUJITSU COMPONENTS EUROPE B.V.  
Diamantlaan 25  
2132 WV Hoofddorp  
Netherlands  
Tel: (31-23) 5560910  
Fax: (31-23) 5560950  
Email: info@fceu.fujitsu.com  
Web: emea.fujitsu.com/components/

### Asia Pacific

FUJITSU COMPONENTS ASIA, Ltd.  
102E Pasir Panjang Road  
#01-01 Citilink Warehouse Complex,  
Singapore 118529  
Tel: (65) 6375-8560 / Fax: (65) 6273-3021  
Email: fcal@sg.fujitsu.com  
www.fujitsu.com/sg/products/devices/  
components/

### China

FUJITSU ELECTRONIC COMPONENTS  
(SHANGHAI) CO., LTD.  
Unit 4306, InterContinental Center  
100 Yu Tong Road, Shanghai 200070, China  
Tel: (86 21) 3253 0998 / Fax: (86 21) 3253 0997  
Email: fcs@cn.fujitsu.com  
www.fujitsu.com/cn/products/devices/  
components/

### Hong Kong

FUJITSU COMPONENTS HONG KONG Co., Ltd.  
Room 06, 28/F, Greenfield Tower, Concordia  
Plaza, No.1 Science Museum Road,  
Tsim Sha Tsui East, Kowloon, Hong Kong  
Tel: (852) 2881 8495 Fax: (852) 2894 9512  
Email: fcal@sg.fujitsu.com  
www.fujitsu.com/sg/products/devices/  
components/

### Korea

FUJITSU COMPONENTS KOREA, LTD.  
Alpha Tower #403,  
645 Sampyeong-dong,  
Bundang-gu, Seongnam-si,  
Gyeonggi-do, 13524 Korea  
Tel: (82 31) 708-7108  
Fax: (82 31) 709-7108  
Email: fcal@sg.fujitsu.com  
www.fujitsu.com/sg/products/  
devices/components/

---

## Copyright

All trademarks or registered trademarks are the property of their respective owners. Fujitsu Components America or its affiliates do not warrant that the content of datasheet is error free. In a continuing effort to improve our products Fujitsu Components America, Inc. or its affiliates reserve the right to change specifications/datasheets without prior notice. Copyright ©2020 Fujitsu Components America, Inc. All rights reserved. Revised October 27, 2020.

---