

used for: D-SUB

POS.	A ^{-0.76}	B ^{+0.25}	C	D ^{-0.3}	Part-NO.
9	31.19	16.79	25.00 ^{+0.12} / _{-0.13}	6.12	DSS1XPXXG04X
15	39.52	25.12	33.30 ^{+0.15} / _{-0.1}	6.12	DSS2XPXXG04X
25	53.42	38.84	47.04 ±0.13	5.99	DSS3XPXXG04X
37	69.70	55.30	63.50 ±0.13	5.99	DSS4XPXXG04X

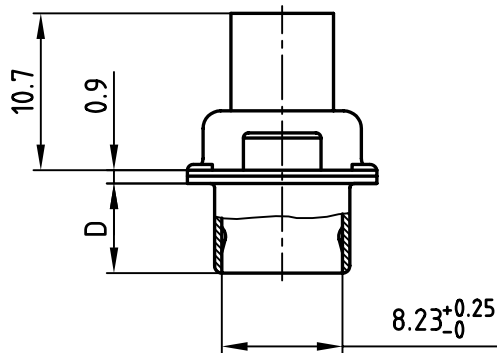
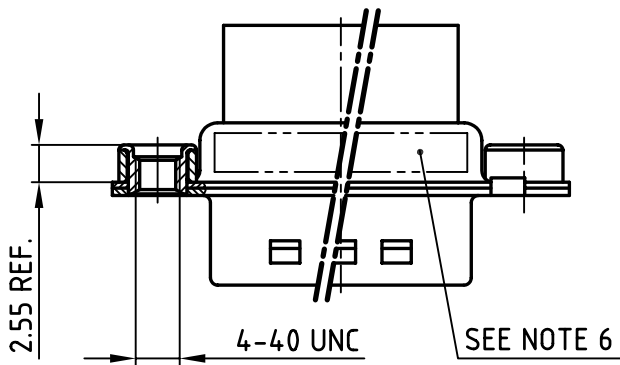
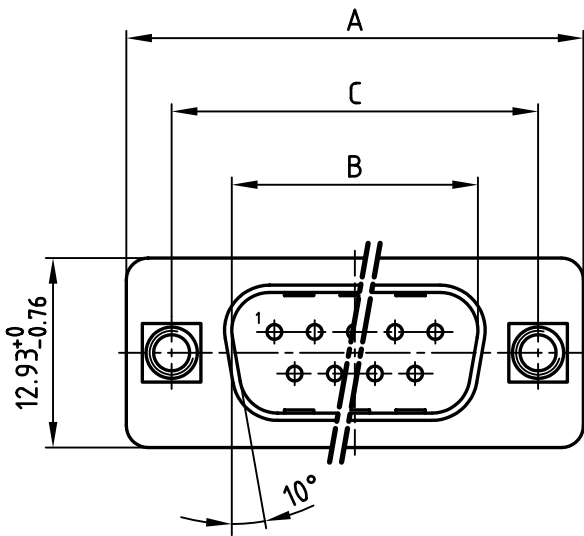

Directive 2002/95/EC
"RoHS"
Compliant

NOTES:

1. METALSHELLS: STEEL; min. 315µin TIN over 40-80µin NICKEL
2. INSULATORS: PBT GF UL 94 V-0, BLACK
3. THREADED INSERT: COPPER ALLOY; min. 200µin TIN over 80µin NICKEL
4. COLLAR: COPPER ALLOY; min. 200µin TIN over 80µin NICKEL
5. MAXIMUM TORQUE VALUE FOR THREAD: 6in.LBS
6. CONNECTOR IS PART MARKED: PART-NO. CONEC ABC

APPROVAL # FREIGABE # DEBLOCAGE # AUTORIZACION # APPROVAL	
CUSTOMER APPROVAL DATE:	
NAME:	TITLE:
COMPANY NAME:	
APPROVAL # FREIGABE # DEBLOCAGE # AUTORIZACION # APPROVAL	

THIS DRAWING MAY NOT BE COPIED OR REPRODUCED IN ANY WAY, AND MAY NOT BE PASSED ON TO A THIRD PARTY WITHOUT WRITTEN PERMISSION. OWNERSHIP AND COPYRIGHT OF CONEC GmbH DO NOT ALTER CAD DRAWING BY HAND

tolerance		 dim. in mm	scale: 2:1
			material: SEE NOTES
		title: D-SUB MALE 9-37pos. CRIMP STYLE with threaded insert	
		dwg no: AutoCAD 2006	
		<div style="font-size: 2em; font-weight: bold; margin: 0;">16K1A1903</div>	
		sh: 1/1	
		part no: SEE TABLE	



rev.	description	date	name
a	Origin		