

# LTC6954

## Low Phase Noise, Triple Output Clock Distribution Divider/Driver

### DESCRIPTION

Demonstration Circuit 1954A features the [LTC®6954](#), a Low Phase Noise, Triple Output Clock Distribution Divider/Driver.

There are four options of the DC1954A, one for each version of the LTC6954. Table 1 summarizes the available DC1954A options.

The DC1954A LVPECL outputs are AC-coupled 50Ω transmission lines making them suitable for driving 50Ω impedance instruments. The LVDS/CMOS outputs of the DC1954A are terminated with a 100Ω differential resistor and are DC-coupled. All differential input and outputs have

0.5" spaced SMA connectors. The LTC6954's EZSync™ function is made available via a turret and an SMA connector.

A DC590 USB serial controller board is used for SPI communication with the LTC6954, controlled by the supplied LTC6954\_GUI software.

**Design files for this circuit board are available at <http://www.linear.com/demo/DC1954A>**

LT, LTC, LTM, Linear Technology and the Linear logo are registered trademarks and EZSync is a trademark of Linear Technology Corporation. All other trademarks are the property of their respective owners.

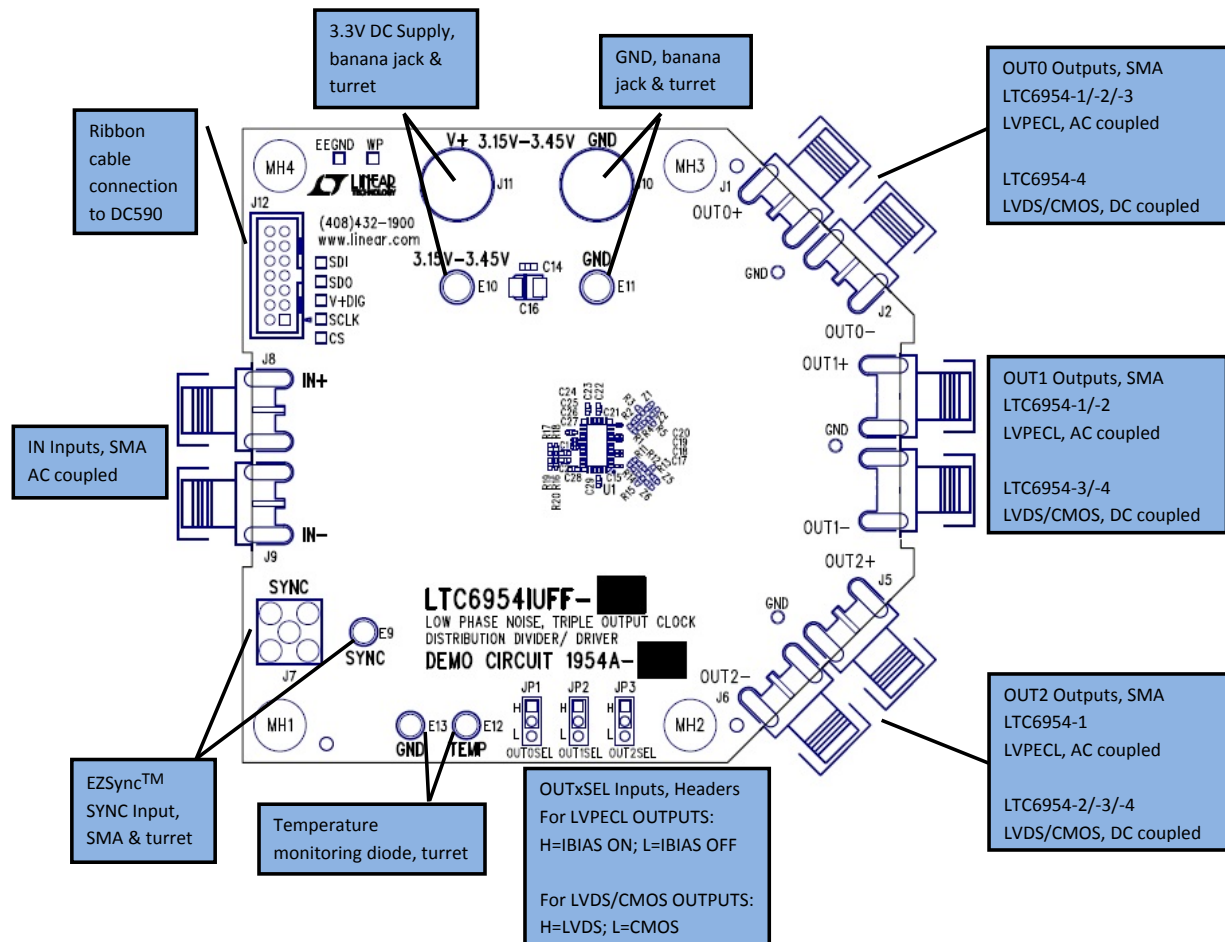

Figure 1. DC1954A Connections

## QUICK START PROCEDURE

The DC1954A is easy to set up to evaluate the performance of the LTC6954. Follow the procedure below.

The DC590 and LTC6954\_GUI application are required to control the DC1954A through a personal computer (PC).

### DC590 Configuration

Place the DC590 jumpers in the following positions (refer to Figure 2):

- JP4:** EE      Must be in the EN position.
- JP5:** ISO     ON must be selected.
- JP5:** SW     ON must be selected.
- JP6:** VCCIO   3.3V or 5V must be selected. This sets the SPI port to 3.3V or 5V operation, 3.3V operation is recommended.

Connect the DC590 to one of your computer's USB ports with the included USB cable.

### LTC6954\_GUI Installation

The LTC6954\_GUI software is used to communicate with the LTC6954. It uses the DC590 to translate between USB and SPI-compatible serial communications formats. The following are the LTC6954\_GUI system requirements:

- Windows Operating System: Windows XP, Windows 2003 Server, Windows Vista, Windows 7
- Microsoft .NET 3.5 SP1 or later
- Windows Installer 3.1 or later
- Linear Technology's DC590 hardware

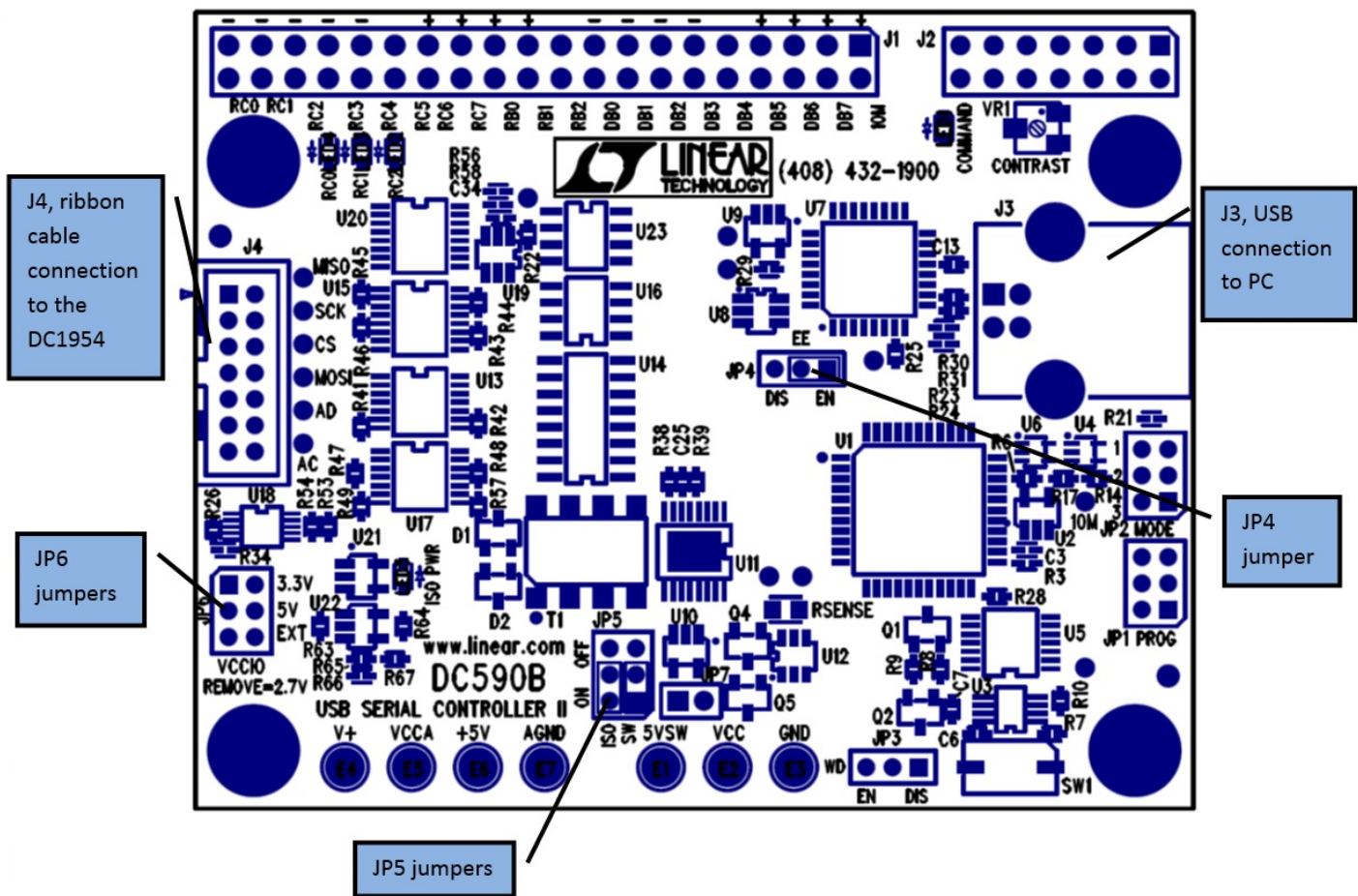

Figure 2. DC590 Jumper and Connector Locations

## QUICK START PROCEDURE

Download the LTC6954\_GUI setup file at:

[www.linear.com/LTC6954\\_GUI](http://www.linear.com/LTC6954_GUI).

Run the LTC6954\_GUI setup file and follow the instructions given on the screen. The setup file will verify and/or install Microsoft .NET and install the LTC6954\_GUI.

### DC1954A Configuration

1. Connect the GND and V+ 3.15V-3.45V, turrets to a power supply and apply power (see Figure 1 and the Typical DC1954A Requirements and Characteristics table).
2. Connect the DC590 to the DC1954A with the provided ribbon cable.
3. Run the LTC6954\_GUI application.
4. From the LTC6954\_GUI, click *File -> Load Settings* and point to the LTC6954.6954set file.
5. From the LTC6954\_GUI, select the Read All button. This will update the GUI to display the correct part number and associated output types.
6. Connect a low phase-noise (or jitter) single-ended or differential signal to IN+ (J8) and/or IN- (J9). Refer to the LTC6954 data sheet for acceptable input frequencies and amplitudes.
7. From the LTC6954\_GUI, update Fin to the frequency of the input signal in step 6. This will update the LTC6954\_GUI with the correct output frequencies.
8. Refer to the Typical DC1954A Requirements and Characteristics table for desired OUTxSEL level. Set JP1, JP2 and JP3 accordingly.
9. Connect desired output (OUT0, OUT1, OUT2) to a test instrument or other demo board to evaluate performance. *[The LVDS/CMOS outputs are DC-coupled, please make sure the levels do not exceed the test equipment input levels].*
10. To synchronize outputs provide a 1ms or greater high pulse to the SYNC SMA to take advantage of the EZSync function.

*Be sure to power down or terminate any unused RF output with 50Ω, or poor spurious performance may result.*

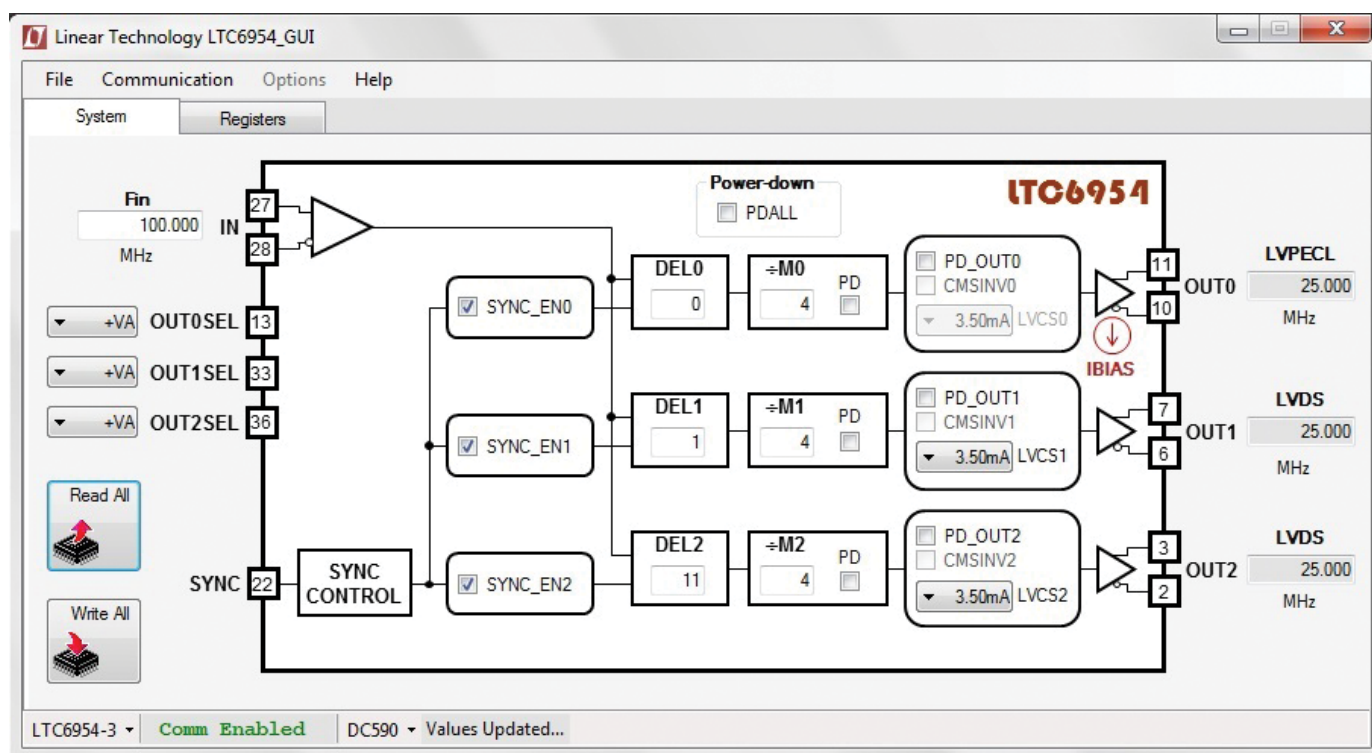

Figure 3. LTC6954\_GUI Screenshot

## QUICK START PROCEDURE

### Troubleshooting

If the board is not functioning as expected, follow the instructions below:

1. Verify that you are able to communicate with the DC1954A. The bottom status line in LTC6954\_GUI should read LTC6954 and Comm Enabled.
2. Verify that V+ 3.15V-3.45V turret has the correct voltage. (see the Typical DC1954A Requirements and Characteristics table).
3. Ensure JP1, JP2, and JP3 are set to desired position.
4. If the output type is LVPECL and the output is AC-coupled, OUTxSEL must be high for proper signal swing.

5. If the output type is LVDS, the outputs must be AC-coupled into single-ended, 50Ω input test equipment. Additionally, the unconnected output must be AC-coupled into a 50Ω load to ground to provide a balanced output load. If the LVCSx bit is low, the signal amplitude at the instrument will be approximately half of the data sheet value due to the existing 100Ω termination on the demo board.
6. If the output is CMOS, a 200Ω series resistor must be included to limit the output current when connecting to the 50Ω input on test equipment. The signal swing at the instrument is then approximately 20 percent of the data sheet value.

Contact the factory for further troubleshooting.

## DC1954A RECONFIGURATION

The DC1954A allows for a variety of input and output configurations. The following covers the hardware reconfiguration of the DC1954A.

### LVPECL Output Options

The DC1954A LVPECL outputs are AC-coupled and require internal biasing (OUTxSEL=H) with the default termination network. The DC1954A provides pull-down, series and a differential termination resistor options to accommodate the other LVPECL termination networks described in the data sheet.

### LVDS/CMOS Output Options

The LVDS/CMOS outputs are DC-coupled and have an on board differential 100Ω resistor termination by default. The DC1954A provides pull-down, series and a differential termination resistor options to accommodate the other LVDS/CMOS termination networks described in the data sheet.

### Input Options

The inputs have a 50Ω termination resistor to GND and are AC-coupled by default. The DC1954A provides pull-down, pull-up and a differential termination resistor options to accommodate the other input termination networks described in the data sheet.

### Clock Follower Input Network

When using the DC1954A as a clock follower, EZSync requires the LTC6954 inputs to be taken to a low state while the SYNC pin is high. To meet this requirement, the DC1954A must be modified to support DC-coupling. Refer to the EZSync Function section and to the data sheet for more details on using the LTC6954 as a clock follower.

### EZSync Function

Apply a 1ms or greater high pulse to the SYNC SMA connector to take advantage of the EZSync function. Refer to the LTC6954 data sheet for SYNC timing and level requirements.

## ASSEMBLY OPTIONS

Table 1. DC1954A Assembly Options

ASSEMBLY VERSION	U1 PART NUMBER	OUT0+/-	OUT1+/-	OUT2+/-
DC1954A-A	LTC6954IUFF-1	LVPECL	LVPECL	LVPECL
DC1954A-B	LTC6954IUFF-2	LVPECL	LVPECL	LVDS/CMOS
DC1954A-C	LTC6954IUFF-3	LVPECL	LVDS/CMOS	LVDS/CMOS
DC1954A-D	LTC6954IUFF-4	LVDS/CMOS	LVDS/CMOS	LVDS/CMOS

dc1954af

## TYPICAL DC1954A REQUIREMENTS AND CHARACTERISTICS

PARAMETER	INPUT OR OUTPUT	PHYSICAL LOCATION	DETAILS
3.3V Power Supply	Input	J11 and J10 Banana Jacks, or 3.15V-3.45V and GND Turrets	Low-Noise and Spur-Free 3.3V, $\geq 400\text{mA}$ Capable Power Supply; Typically DC1954 Consumes $\sim 300\text{mA}$ ; Powers LTC6954, U2, U3, and U4
OUT0+, OUT0-	Two Outputs	J1 and J2 SMA Connectors*	Refer to Figure 1 or Table 1 for Output Type <b>If LVPECL:</b> AC-Coupled <b>If LVDS/CMOS:</b> DC-Coupled Refer to LTC6954 Data Sheet for Output Levels for LVPECL, or LVDS/CMOS Option
OUT1+, OUT1-	Two Outputs	J3 and J4 SMA Connectors*	
OUT2+, OUT2-	Two Outputs	J5 and J6 SMA Connectors*	
OUT0SEL	Input	JP1 3-Pin Headers	<b>If LVPECL:</b> OUTxSEL=H: IBIAS=ON, for Default LVPECL BOM OUTxSEL=L: IBIAS=OFF, Must Install External Pull-Down Resistor, Refer to schematic <b>If LVDS/CMOS:</b> OUTxSEL=H: LVDS, Default LVDS/CMOS BOM OUTxSEL=L: CMOS, Remove $100\Omega$ Differential Termination, Refer to Schematic
OUT1SEL	Input	JP2 3-Pin Headers	
OUT2SEL	Input	JP3 3-Pin Headers	
TEMP	Input/Output	Turret	Temperature Monitoring Diode; Force Current Measure Voltage, Refer to Data Sheet
TEMP GND	Input	Turret	
SYNC	Input	J7 SMA Connector and Turret	EZSync, 0V to 3.3V Control Signal, Refer to the Data Sheet
IN+, IN-	Input	J8 and J9 SMA Connectors	Input Signal Pins

\*Any unused RF output *must* be powered down or terminated with  $50\Omega$ , or poor spurious performance may result.

## PCB LAYOUT

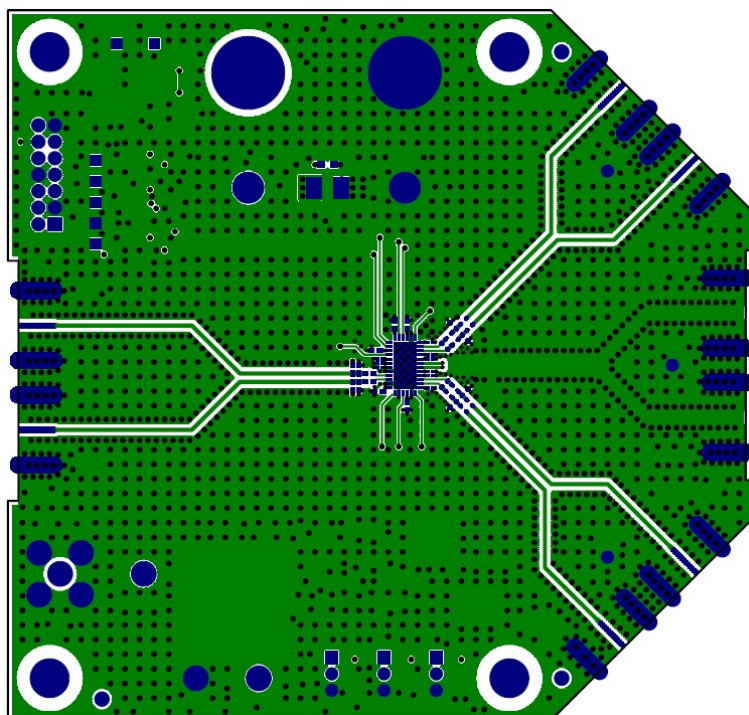

Top Layer

# DEMO MANUAL DC1954A

## PARTS LIST

ITEM	QTY	REFERENCE	PART DESCRIPTION	MANUFACTURER/PART NUMBER
<b>Required Circuit Components</b>				
2	17	C1-C10, C12, C13, C22-C24, C28, C29	CAP., X7R, 0.1µF, 10V, 10%, 0402	AVX, 0402ZC104KAT2A
3	1	C14	CAP., X7R, 1.0µF, 16V, 10%, 0603	AVX, 0603YC105KAT2A
4	9	C15, C17-C21, C25-C27	CAP., X7R, 0.01µF, 6.3V, 10%, 0201	MURATA, GRM033R70J103KA01D
5	1	C16	CAP., TANT, 22µF 10V, 3528	AVX, TPSB226K010R0400
6	3	E9, E12, E13	TURRET, 0.064"	MILL-MAX, 2308-2-00-80-00-00-07-0
7	2	E10, E11	TURRET, 0.094"	MILL-MAX, 2501-2-00-80-00-00-07-0
8	3	JP1, JP2, JP3	JMP, 3 PINS 2mm CTRS.	SAMTEC, TMM-103-02-L-S
9	8	J1-J6, J8, J9	CONN., SMA 50Ω EDGE-LAUNCH	EMERSON, 142-0701-851
10	1	J7	CONN, SMA STRAIGHT	CONNEX, 132134
11	2	J10, J11	JACK, BANANA	KEYSTONE, 575-4
12	1	J12	CONN., HEADER 14POS 2mm VERT GOLD	MOLEX, 87831-1420
13	6	R2, R4, R7, R9, R12, R14	RES., CHIP, 0Ω, 5% 0402	NIC, NRC04Z0TRF
14	0	R3, R5, R8, R10, R13, R15-R17, R19	RES., CHIP, 0402	OPT
15	2	R18, R20	RES., CHIP, 49.9Ω, 1/16W, 1%, 0402	NIC, NRC04F49R9TRF
16	5	R22, R35, R37-R39	RES., CHIP, 200k, 1/16W, 1%, 0402	NIC, NRC04F2003TRF
17	3	R23, R24, R25	RES., CHIP, 4.99k, 1/16W, 1%, 0402	NIC, NRC04F4991TRF
18	1	R26	RES., CHIP, 0Ω, 0603	NIC, NRC06Z0TRF
19	0	R27-R29, R30-R32	RES., CHIP, 0603	OPT
20	4	R33, R34, R36, R40	RES., CHIP, 100Ω, 1/16W, 5%, 0402	NIC, NRC04J101TRF
21	2	U2, U3	I.C., DUAL BUFFER, SC70-6	FAIRCHILD SEMI., NC7WZ17P6X
22	1	U4	I.C., DUAL TRANSCEIVER, SOT363	NXP, 74LVC1T45GW
23	1	U5	I.C., EEPROM 2KBIT 400KHZ 8TSSOP	MICROCHIP, 24LC025-I /ST
24	3	SHUNTS SHOWN ON ASSY DWG	SHUNT, 2mm CTRS.	SAMTEC, 2SN-BK-G
<b>DC1954A-A Required Circuit Components</b>				
1	1		GENERAL BOM	
2	0	R1, R6, R11	RES., CHIP, 0402	OPT
3	6	Z1, Z2, Z3, Z4, Z5, Z6	CAP., X7R, 0.1µF 16V, 10%, 0402	AVX, 0402YC104KAT2A
4	1	U1	I.C., QFN36UFF-4X7	LINEAR TECH., LTC6954IUFF-1#PBF

## PARTS LIST

ITEM	QTY	REFERENCE	PART DESCRIPTION	MANUFACTURER/PART NUMBER
<b>DC1954A-B Required Circuit Components</b>				
1	1		GENERAL BOM	
2	0	R1, R6	RES., CHIP, 0402	OPT
3	1	R11	RES., CHIP, 100Ω 1/16W, 5%, 0402	NIC, NRC04J101TRF
4	4	Z1-Z4	CAP., X7R, 0.1μF 16V, 10%, 0402	AVX, 0402YC104KAT2A
5	2	Z5, Z6	RES., CHIP, 0Ω, 0402	NIC, NRC04Z0TRF
6	1	U1	I.C., QFN36UFF-4X7	LINEAR TECH., LTC6954IUFF-2#PBF
<b>DC1954A-C Required Circuit Components</b>				
1	1		GENERAL BOM	
2	0	R1	RES., CHIP, 0402	OPT
3	2	R6, R11	RES., CHIP, 100Ω 1/16W, 5%, 0402	NIC, NRC04J101TRF
4	2	Z1-Z2	CAP., X7R, 0.1μF 16V, 10%, 0402	AVX, 0402YC104KAT2A
5	4	Z3, Z4, Z5, Z6	RES., CHIP, 0Ω, 0402	NIC, NRC04Z0TRF
6	1	U1	I.C., QFN36UFF-4X7	LINEAR TECH., LTC6954IUFF-3#PBF
<b>DC1954A-D Required Circuit Components</b>				
1	1		GENERAL BOM	
2	3	R1, R6, R11	RES., CHIP, 100Ω 1/16W, 5%, 0402	NIC, NRC04J101TRF
3	6	Z1, Z2, Z3, Z4, Z5, Z6	RES., CHIP, 0Ω, 0402	NIC, NRC04Z0TRF
4	1	U1	I.C., QFN36UFF-4X7	LINEAR TECH., LTC6954IUFF-4#PBF





**SCHEMATIC DIAGRAM**

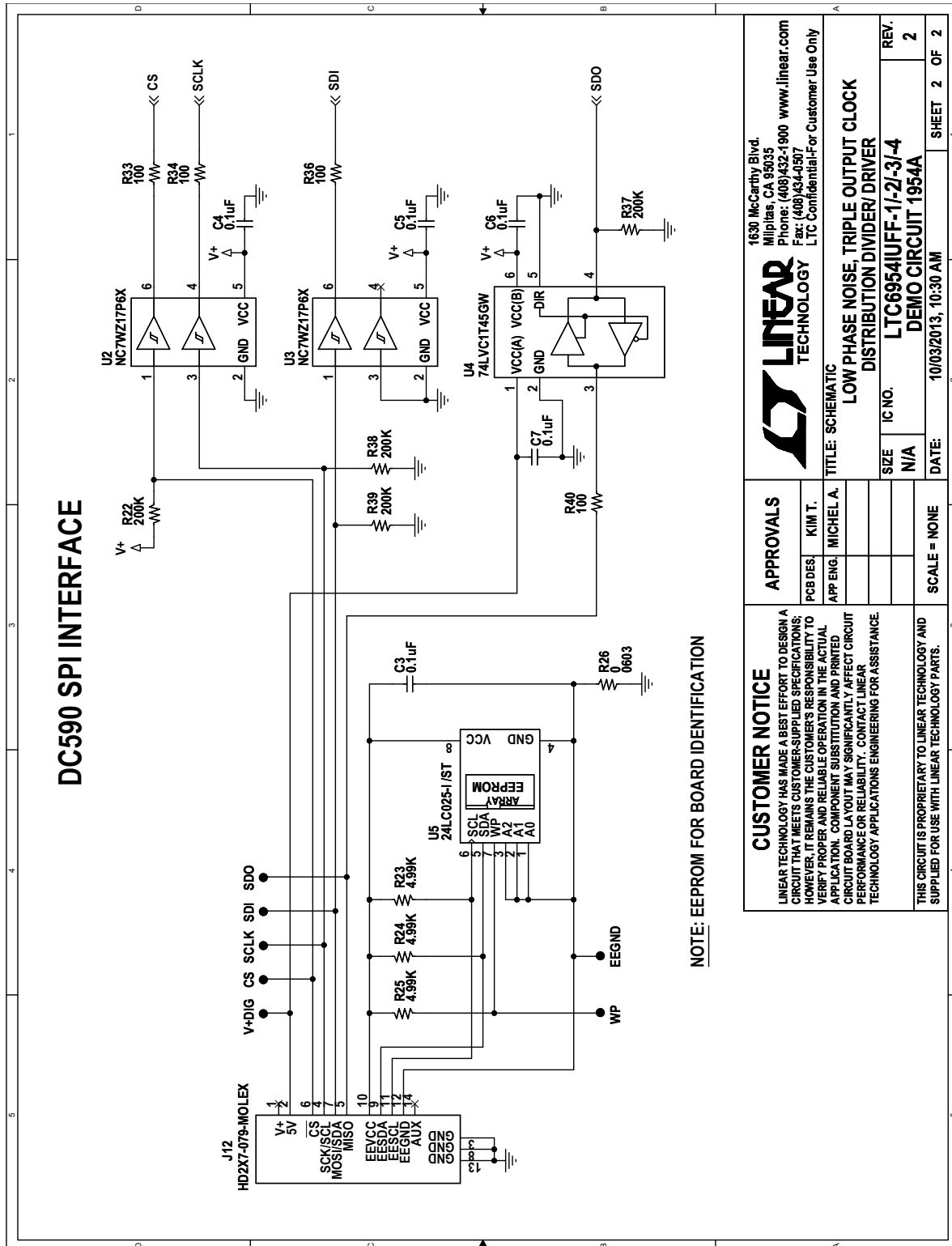

Note: The buffers shown on sheet 2 of 2 of the schematic are used to protect the LTC6954 when connected to the DC590 before the LTC6954 is powered up. There is no need for such circuitry if the SPI bus is not active before powering up the LTC6954. The EEPROM is for identification and is not needed to program the LTC6954.

<p>1630 McCarthy Blvd. Milpitas, CA 95035 Phone: (408)432-1900 www.linear.com Fax: (408)434-0507 LTC Confidential-For Customer Use Only</p>	
<p><b>LINEAR TECHNOLOGY</b></p>	
<p>TITLE: SCHEMATIC LOW PHASE NOISE, TRIPLE OUTPUT CLOCK DISTRIBUTION DIVIDER/ DRIVER</p>	
SIZE	IC NO.
N/A	LTC6954UIFF-1/-2/-3/-4
DATE:	REV.
10/03/2013, 10:30 AM	2
SCALE = NONE	SHEET 2 OF 2

<b>CUSTOMER NOTICE</b>	
<p>LINEAR TECHNOLOGY HAS MADE A BEST EFFORT TO DESIGN A CIRCUIT THAT MEETS CUSTOMER-SUPPLIED SPECIFICATIONS; HOWEVER, IT REMAINS THE CUSTOMER'S RESPONSIBILITY TO VERIFY PROPER AND RELIABLE OPERATION IN THE ACTUAL APPLICATION. COMPONENT SUBSTITUTION AND PRINTED CIRCUIT BOARD LAYOUT MAY SIGNIFICANTLY AFFECT CIRCUIT PERFORMANCE OR RELIABILITY. CONTACT LINEAR TECHNOLOGY APPLICATIONS ENGINEERING FOR ASSISTANCE.</p>	
<p>THIS CIRCUIT IS PROPRIETARY TO LINEAR TECHNOLOGY AND SUPPLIED FOR USE WITH LINEAR TECHNOLOGY PARTS.</p>	
<b>APPROVALS</b>	
PCB DES.	KIM T.
APP ENG.	MICHEL A.
SCALE = NONE	

NOTE: EEPROM FOR BOARD IDENTIFICATION

# DEMO MANUAL DC1954A

---

## DEMONSTRATION BOARD IMPORTANT NOTICE

Linear Technology Corporation (LTC) provides the enclosed product(s) under the following **AS IS** conditions:

This demonstration board (DEMO BOARD) kit being sold or provided by Linear Technology is intended for use for **ENGINEERING DEVELOPMENT OR EVALUATION PURPOSES ONLY** and is not provided by LTC for commercial use. As such, the DEMO BOARD herein may not be complete in terms of required design-, marketing-, and/or manufacturing-related protective considerations, including but not limited to product safety measures typically found in finished commercial goods. As a prototype, this product does not fall within the scope of the European Union directive on electromagnetic compatibility and therefore may or may not meet the technical requirements of the directive, or other regulations.

If this evaluation kit does not meet the specifications recited in the DEMO BOARD manual the kit may be returned within 30 days from the date of delivery for a full refund. **THE FOREGOING WARRANTY IS THE EXCLUSIVE WARRANTY MADE BY THE SELLER TO BUYER AND IS IN LIEU OF ALL OTHER WARRANTIES, EXPRESSED, IMPLIED, OR STATUTORY, INCLUDING ANY WARRANTY OF MERCHANTABILITY OR FITNESS FOR ANY PARTICULAR PURPOSE. EXCEPT TO THE EXTENT OF THIS INDEMNITY, NEITHER PARTY SHALL BE LIABLE TO THE OTHER FOR ANY INDIRECT, SPECIAL, INCIDENTAL, OR CONSEQUENTIAL DAMAGES.**

The user assumes all responsibility and liability for proper and safe handling of the goods. Further, the user releases LTC from all claims arising from the handling or use of the goods. Due to the open construction of the product, it is the user's responsibility to take any and all appropriate precautions with regard to electrostatic discharge. Also be aware that the products herein may not be regulatory compliant or agency certified (FCC, UL, CE, etc.).

No License is granted under any patent right or other intellectual property whatsoever. **LTC assumes no liability for applications assistance, customer product design, software performance, or infringement of patents or any other intellectual property rights of any kind.**

LTC currently services a variety of customers for products around the world, and therefore this transaction **is not exclusive**.

**Please read the DEMO BOARD manual prior to handling the product.** Persons handling this product must have electronics training and observe good laboratory practice standards. **Common sense is encouraged.**

This notice contains important safety information about temperatures and voltages. For further safety concerns, please contact a LTC application engineer.

Mailing Address:

Linear Technology  
1630 McCarthy Blvd.  
Milpitas, CA 95035

Copyright © 2004, Linear Technology Corporation

dc1954af