

# 5kV, 4mm Sheathed Banana Jack, Panel Mount, 4.8mm Quick Connect

CT4008-#



## Features:

- 1,000 V CAT IV, 5 kV non-category with 2 kV transient overvoltage
- Ø4.8 mm Quick connect termination
- 10 A Max
- Panel mount
- CE listed
- RoHS 2 compliant

## Measurement Drawing: (dimensions in mm, not to scale)

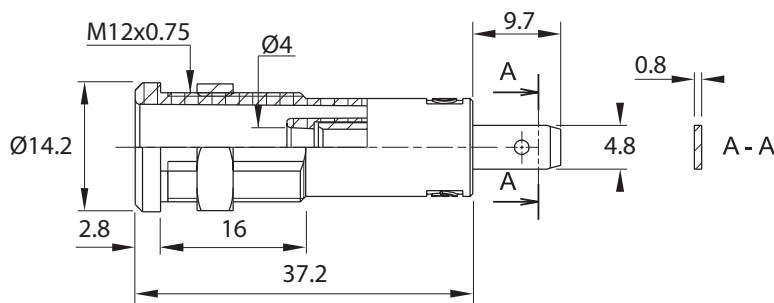

## Description:

The CT4008 operates up to 5 kV when used in non-category environments with transient overvoltages up to 2 kV.<sup>a</sup> This jack also extends the rating of our 4mm Sheathed Banana Jacks to 1,000 V CAT IV.<sup>b</sup>

For use only with Cal Test's Long-Reach High Voltage Test Leads, CT3018 or CT3020. The jack offers a Ø4.8 mm quick connect tab. The jack fits into both plastic and metal panels fixed with a 14.5 mm hex panel nut.

The CT4008 is available in 2 colors.

a. Never hold or touch equipment while connected to live voltages.

b. Must be used in conjunction with other similarly rated products.

Specifications and appearance subject to change without notice  
D400800 020720

1 - [www.caltestelectronics.com](http://www.caltestelectronics.com)

**Cal Test**  
ELECTRONICS

## Order Information:

### **CT4008-#**

5kV, 4mm Sheathed Banana Jack, Panel Mount, 4.8mm Quick Connect

- Color: replace ‘#’ with dash number:  
-0 Black, -2 Red

## Contact Info:

Toll Free: 800-572-1028 (US Only)

Phone: 714-221-9330

Fax: 714-921-9849

22820 Savi Ranch Parkway

Yorba Linda, CA 92887-4610 USA

[www.caltestelectronics.com](http://www.caltestelectronics.com)

CE

Copyright © 2020, Cal Test Electronics, Inc. All rights reserved. Information in this publication supersedes that in all previously published material. Trade names referenced are the service marks, trademarks or registered trademarks of their respective companies.