

**Murata Type ABR
mikroBUS™
EVB Datasheet**

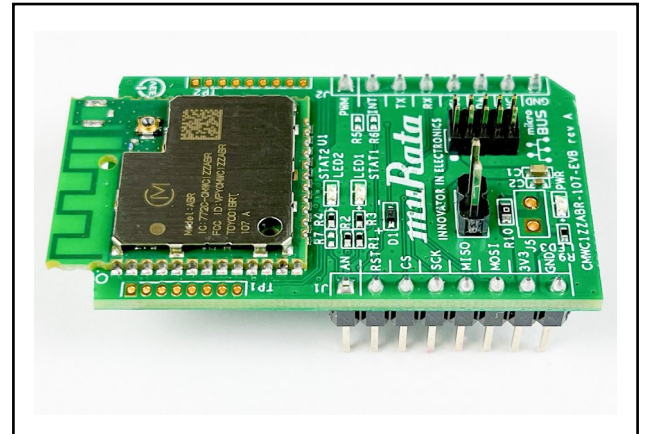

Revision History

Revision	Date	Author	Change Description
1.0	April 9, 2021	TF	Initial release
1.1	April 23, 2021	TF	Revise Acronym table, clarify VIO and u.FL option.

Table of Contents

1	MURATA TYPE ABR MIKROBUS™ EVB	4
1.1	INTRODUCTION	4
1.2	ACRONYMS	4
1.3	REFERENCES	5
1.3.1	<i>Murata Type ABR mikroBUS EVB Quick Start Guide</i>	5
1.3.2	<i>Murata Type ABR mikroBUS Flashing Guide</i>	5
1.3.3	<i>Murata Type ABR Module Webpage</i>	5
1.3.4	<i>Murata Type ABR Module Datasheet</i>	5
1.3.5	<i>Murata Community Forum Support</i>	5
1.3.6	<i>NXP 88MW32X Landing Page</i>	5
2	MURATA KIT CONTENTS	6
3	TYPE ABR EVB HIGH-LEVEL DESCRIPTION	6
4	TYPE ABR EVB: HEADERS, JUMPERS, AND FEATURES IN DETAIL	10
4.1	J1: MIKROBUS HEADER	10
4.2	J2: MIKROBUS HEADER	10
4.3	J3: BOOT MODE SELECTOR	10
4.4	J4: ARM 10-PIN INTERFACE SWD MODE	10
4.5	J5: OPTIONAL CURRENT MEASUREMENT HEADER	10
4.6	TP1: TEST POINT HEADER	10
4.7	TP2: TEST POINT HEADER	10
4.8	LED1: MODULE READY INDICATOR	11
4.9	LED2: WLAN LINK INDICATOR	11
4.10	LED3: POWER SUPPLY INDICATOR	11
4.11	RF COAXIAL CONNECTOR	11
4.12	OPTIONAL U.FL CONNECTOR	11
5	TYPE ABR MIKROBUS EVB SCHEMATIC AND LAYOUT	12
6	TYPE ABR EVB PRE-FLASHED FIRMWARE IMAGE	16
6.1	FUNCTIONALITY OVERVIEW	16
6.2	WMSDKA BACKGROUND	16
7	TYPE ABR EVB LED STATUS	17

List of Figures

FIGURE 1:	MURATA TYPE ABR EVB	6
FIGURE 2:	TYPE ABR EVB FEATURES (TOP VIEW)	8
FIGURE 3:	TYPE ABR EVB FEATURES (BOTTOM VIEW)	9
FIGURE 4:	TYPE ABR MIKROBUS EVB SCHEMATIC	13
FIGURE 5:	TYPE ABR MIKROBUS EVB LAYOUT (TOP)	14
FIGURE 6:	TYPE ABR MIKROBUS EVB LAYOUT (BOTTOM)	15
FIGURE 7:	LED1/LED2 STATUS FLOW DIAGRAM DURING “SERIAL_MWM_DEMO” EXECUTION	17

List of Tables

TABLE 1: ACRONYMS USED IN TYPE ABR EVB DATASHEET.....	4
TABLE 2: TYPE ABR MIKROBUS EVB FEATURES	7
TABLE 3: GPIO FUNCTION ASSIGNMENT	11
TABLE 4: LED1/LED2 STATUS DURING “SERIAL_MWM_DEMO” EXECUTION.....	17

1 Murata Type ABR mikroBUS™ EVB

1.1 Introduction

Murata has partnered closely with [Embedded Artists AB](#) to provide a flexible evaluation board solution for Murata's Type ABR module (based on NXP's 88MW320 chipset). Murata's Type ABR EVB is designed with mikroBUS™ interconnect. Type ABR EVB connects directly with NXP's LPC EVK's like LPCXpresso55S69 Development Board ([LPC55S69-EVK](#)). It can also connect to NXP's i.MX RT EVK family (like [MIMXRT1010-EVK](#)) with an Arduino adapter - see MIKROE's Arduino UNO click shield ([MIKROE-1581](#)).

Type ABR is a small module (integrated PCB antenna) based on NXP 88MW320 (wireless microcontroller), supporting Wi-Fi® 802.11 b/g/n up to 72.2 Mbps PHY data rate; with an integrated 200MHz ARM Cortex-M4F MCU for host-side applications. For more information on Type ABR, please refer to [this link](#).

1.2 Acronyms

Refer to **Table 1** for various acronyms used in this document.

Table 1: Acronyms used in Type ABR EVB Datasheet

Acronym	Meaning
AP	Access Point
ARM	Acorn Reduced Instruction Set Computing Machine
CLK	Clock
CTRL	Control
CTS _n	Clear to Send (active low)
EVB	Evaluation Board
EVK	Evaluation Kit
GND	Ground
GPIO	General Purpose Input Output
I ² C	Inter-Integrated Circuit
IDE	Integrated Development Environment
JTAG	Joint Test Action Group
LED	Light-emitting Diode
MCU	Microcontroller Unit
PCB	Printed Circuit Board
PHY	Physical Layer
RF	Radio Frequency
RTS _n	Request to Send (active low)
RXD / RX	Receive Data
SCL	Serial Clock
SDA	Serial Data
SPI	Serial Peripheral Interface
SWD	Serial Wire Debug
TXD / TX	Transmit Data
UART	Universal Asynchronous Receiver/Transmitter

Acronym	Meaning
VBAT	Voltage of Battery
VIO	Input Offset Voltage
Wi-Fi	Wireless LAN: “Wi-Fi” is a registered trademark of Wi-Fi Alliance
WLAN	Wireless Local Area Network

1.3 References

1.3.1 Murata Type ABR mikroBUS EVB Quick Start Guide

This [Quick Start](#) steps the user on how to quickly connect Murata’s Type ABR EVB to NXP’s LPC55S69-EVK and get it running in NXP’s MCUXpresso IDE.

1.3.2 Murata Type ABR mikroBUS Flashing Guide

This [flashing guide](#) provides detailed steps on how to flash Murata’s Type ABR EVB using NXP’s LPC-Link2 debug probe.

1.3.3 Murata Type ABR Module Webpage

This [website landing page](#) provides latest/comprehensive information on Murata’s Type ABR module.

1.3.4 Murata Type ABR Module Datasheet

The ABR module datasheet is included on the ABR module webpage. You can also access it easily [from this link](#).

1.3.5 Murata Community Forum Support

Murata’s Community provides online support for Murata’s Type ABR module and Type ABR mikroBUS EVB. Refer to [this link](#) for all Forum threads on Type ABR.

1.3.6 NXP 88MW32X Landing Page

NXP provides extensive documentation and WMSDKA source code at [this link](#).

2 Murata Kit Contents

The Murata Type ABR mikroBUS EVB (Part No: CMWC1ZZABR-107-EVB) kit consists of one part only. The packaging and EVB are shown below in **Figure 1**.

Figure 1: Murata Type ABR EVB



3 Type ABR EVB High-Level Description

Figure 2 and **Figure 3** highlight the Type ABR EVB features; with text explanation in **Table 2**.

Murata's Type ABR EVB brings out the following interfaces on mikroBUS™ pins (J1/J2 headers):

- WLAN-UART interface (UART0: TXD, RXD).
- WLAN-SPI interface (SSP1: FRM, CLK, TXD, RXD).
- I²C interface (I²C1: SCL, SDA).
- Power supply (3.3V VBAT and GND).
- WLAN reset control signal (RESET_N).
- Wake up signals (WAKE_UP0, WAKE_UP1) – **not connected** (see R5/R7).
- WLAN-UART debug signal (UART2_TXD) – **not connected** (see R6).

Additional signals are brought out on test point headers TP1 and TP2:

- WLAN-UART signals for optional flow control (UART0: CTSn, RTSn).
- WLAN-UART debug signals (UART2: TXD, RXD).
- Wake up signals (WAKE_UP0, WAKE_UP1).
- Strapping signals (STRAP0/STRAP1) controlling boot mode.
- READY (LED1), and LINK (LED2) status indicators.
- I²C interface (I²C0: SCL, SDA).
- JTAG_TRST (not used in SWD mode).
- Additional GPIO's (24, 39, 46, 47).

Additional features on Type ABR mikroBUS EVB include:

- Flashing interface via Cortex Debug 10-pin connector J4 supporting SWD mode. Murata supports NXP's LPC-Link2 debug probe (flashed with Segger J-Link firmware).
- Boot mode jumper J3 which allows user to control booting from flash (default) or UART.
- Optional header J5 for measuring current consumption (not populated).

Table 2: Type ABR mikroBUS EVB Features

Char	Description
A	Type ABR Module (Murata Part Number: CMWC1ZZABR-107)
B	TP1 header pin #1 – test points.
C	J1 header pin #1 – J1 pins connects to mikroBUS.
D	LED2 is yellow - WLAN link indicator.
E	LED1 is red - module ready indicator.
F	J3 is boot mode header – insert jumper to boot from UART. Leave open for default flash.
G	J5 is optional header to measure current consumption (remove R10).
H	LED3 is green – power LED indicates when 3.3V VBAT and GND are connected.
I	ARM 10-pin interface SWD mode – pin #1 is top left.
J	J2 header pin #1 – J2 pins connect to mikroBUS.
K	TP2 header pin #1 – test points.
L	RF coaxial connector with switch (Part Number: MM8030-2610RK0). Use Murata test probe MXHQ87WJ3000 for conducted testing.
M	Optional mounting location for u.FL connector to connect custom external antenna.
N	TP2 header pin #1 – test points.
O	J2 header pin #1 – J2 pins connect to mikroBUS.
P	ARM 10-pin interface SWD mode – pin #1 is top right.
Q	J3 is boot mode header.
R	J5 is optional header to measure current consumption (remove R10).
S	J1 header pin #1 – J1 pins connects to mikroBUS.
T	TP1 header pin #1 – test points.

Figure 2: Type ABR EVB Features (Top View)

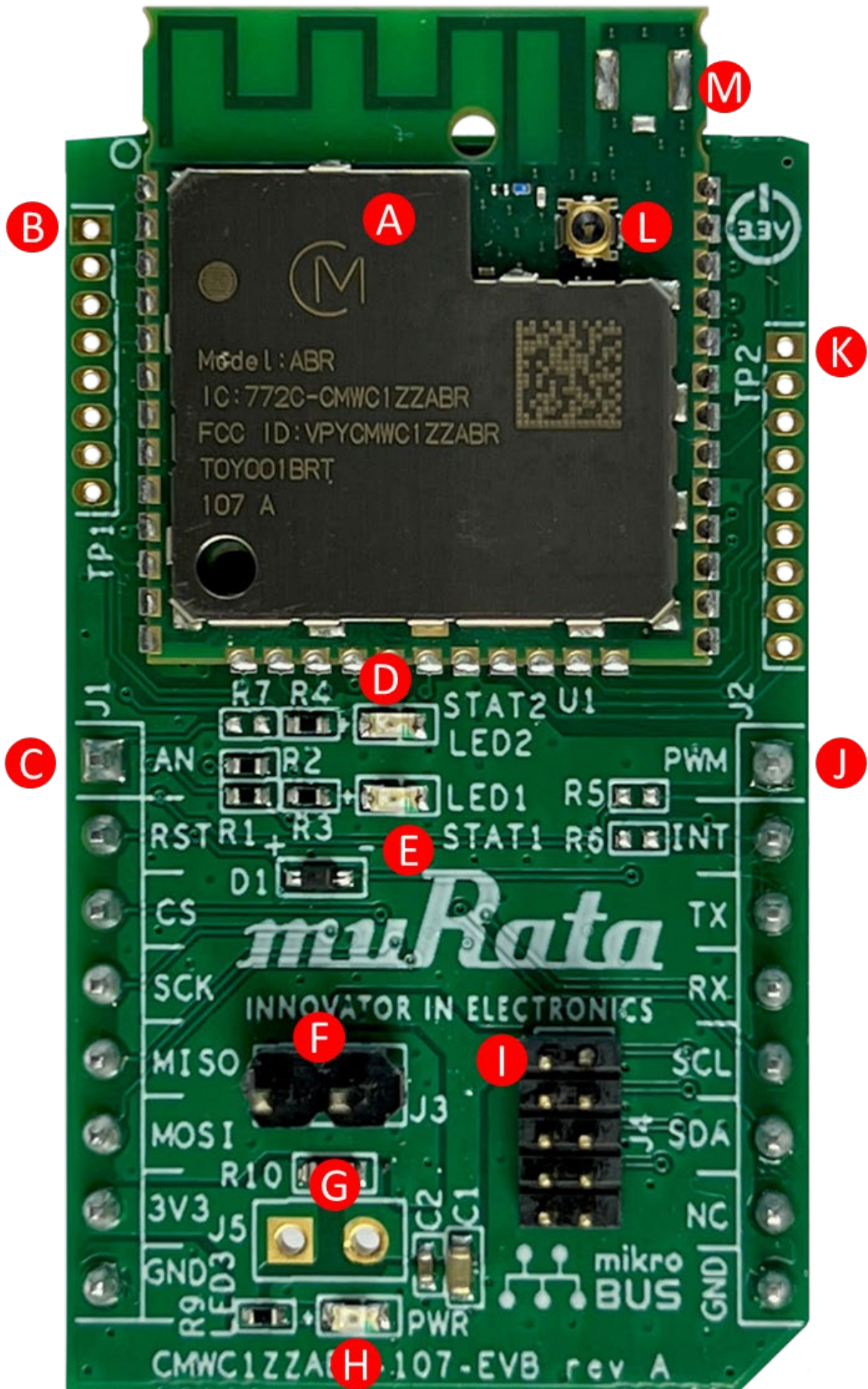
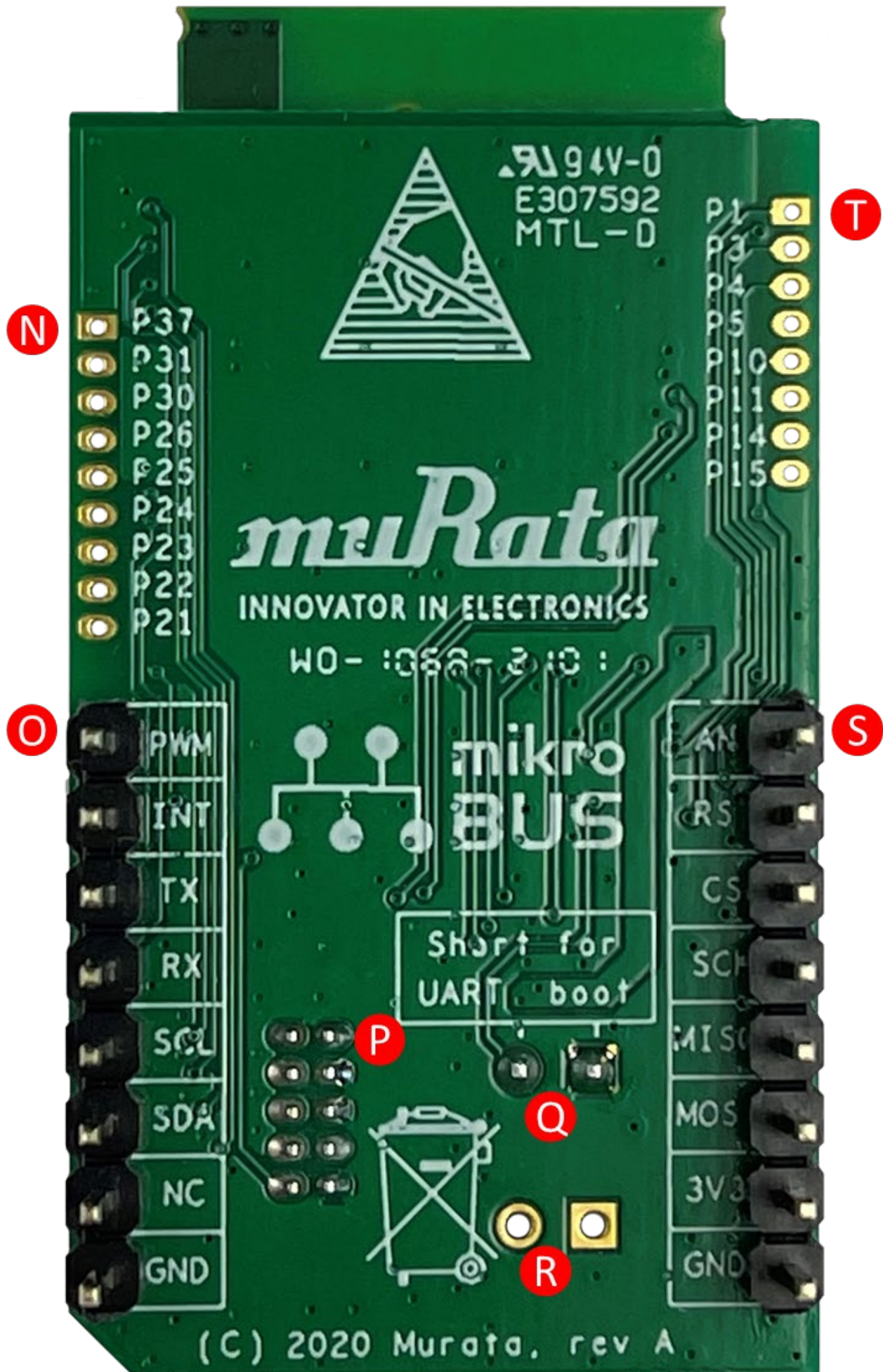

Figure 3: Type ABR EVB Features (Bottom View)



4 Type ABR EVB: Headers, Jumpers, and Features in Detail

To better understand the Type ABR mikroBUS EVB refer to **Figure 4: Type ABR mikroBUS EVB Schematic**, **Figure 5: Type ABR mikroBUS EVB Layout (top)**, and **Figure 6: Type ABR mikroBUS EVB Layout (bottom)**. In the following subsections we look at various headers, jumpers, and features in detail. **Note that all I/O signals should be driven a fixed VIO of 3.3V.**

4.1 J1: mikroBUS Header

Reset, power (3.3V VBAT and GND), and SPI connections are provided on this header. Optional wake signal (WAKE_UP0) can be connected to this header if R7 is populated with zero Ohm resistor.

4.2 J2: mikroBUS Header

UART (TX/RX), I²C, and GND connections are provided on this header. Optional wake (WAKE_UP1) and debug UART TX signals can be connected to this header if R5 and R6 (respectively) are populated with zero Ohm resistors. The UART TX/RX signals brought on this header are the default communication link to the Type ABR module. **Note:** in default configuration there is no flow control implemented. Optional CTSn/RTSn signals are brought on TP2 header. User will need modified firmware image to implement flow control over this UART connection.

4.3 J3: Boot Mode Selector

Selects between UART and default flash boot. Insert jumper for UART boot – sometimes used to flash device. Note that the Murata-recommended flashing method is using ARM 10-pin interface (configured for SWD mode). When J3 jumper is inserted, then STRAP0 and STRAP1 input signals are pulled low.

4.4 J4: ARM 10-pin Interface SWD Mode

ARM 10-pin interface to flash Type ABR module. This provides a fast and reliable interface to flash the onboard ABR module. Murata recommends using NXP's LPC-Link2 (**Part Number:** OM13054) as hardware flashing interface. Refer to [Murata Type ABR mikroBUS Flashing Guide](#) for specific details on flashing steps.

4.5 J5: Optional Current Measurement Header

This header is not populated. Users looking to perform current measurements can perform minor rework to add this header and either use a current meter; or replace R10 with a precision resistor and use a digital multimeter.

4.6 TP1: Test Point Header

Optional signals brought out to this unpopulated test point header. Notable signals brought out to this header include “module ready” (READY) and “WLAN link” (LINK) signals; as well as boot mode (STRAP0/STRAP1) signals. Refer to **Table 1: Acronyms used in Type ABR EVB Datasheet**, and **Figure 4: Type ABR mikroBUS EVB Schematic** for more details on the specific signals brought out.

4.7 TP2: Test Point Header

Optional signals brought out to this unpopulated test point header. Notable signals brought out to this header include UART debug and flow control signals. Refer to **Table 1: Acronyms used in Type ABR EVB Datasheet**, and **Figure 4: Type ABR mikroBUS EVB Schematic** for more details on the specific signals brought out.

4.8 LED1: Module Ready Indicator

Red LED that indicates “module ready” status. This LED is used to show pass/fail status of firmware execution. Refer to **Table 3: GPIO Function Assignment** and [Murata Type ABR mikroBUS EVB Quick Start Guide](#) for specifics.

4.9 LED2: WLAN Link Indicator

Yellow LED that indicates “WLAN link” status. This LED is used to show provisioning mode, and AP association status. Refer to **Table 3: GPIO Function Assignment** and [Murata Type ABR mikroBUS EVB Quick Start Guide](#) for specifics.

4.10 LED3: Power Supply Indicator

Green LED which shows when 3.3V VBAT and GND are applied to Type ABR EVB.

4.11 RF Coaxial Connector

Connector used to provide users a quick/simple method to perform conducted testing without reworking the Type ABR module. The Murata part number for this “switch connector” is MM8030-2610RK0. The correct Murata test probe to use for conducted RF testing is MXHQ87WJ3000. When the test probe is inserted, the coaxial connector disconnects the RF trace to the onboard PCB trace antenna thereby providing a terminated connection to the RF OUT pin on Type ABR module.

4.12 Optional u.FL Connector

Referring to letter “M” on **Figure 2: Type ABR EVB Features (Top View)**, there is an option for a soldered-down u.FL connector to connect an external antenna. However, component rework underneath the module shield is required for this modification. If you are interested in this option, then please contact Murata Sales network.

Table 3: GPIO Function Assignment

GPIO #	Signal	I/O	Connect	Function	Notes
0	UART0_CTSn	I	TP2-5	2	UART 0 CTSn (active low)
1	UART0_RTSn	O	TP2-4	2	UART 0 RTSn (active low)
2	UART0_TXD	O	J2-3	2	UART 0 TXD
3	UART0_RXD	I	J2-4	2	UART 0 RXD
4	I2C0_SDA	I/O	TP2-3	0	I2C 0 SDA
5	I2C0_SCL	I/O	TP2-2	0	I2C 0 SCL
6	SWO	O	J4-6	0	SWD mode (JTAG_TDO alternate)
7	SWCLK	I	J4-4	0	SWD mode (JTAG_TCK alternate)
8	SWDIO	I/O	J4-2	0	SWD mode (JTAG_TMS alternate)
9	NC/EXTb	I	J4-8	0	SWD mode (JTAG_TDI alternate)
10	JTAG_TRSTn*	I	TP2-1	0	JTAG Test Reset (active low) – not used; not connected to JTAG 10-pin header (J4).

GPIO #	Signal	I/O	Connect	Function	Notes
16	STRAP1	I/O	J3-2, TP1-1	1	Boot Mode: Short J3 = boot from UART; Disconnect J3 = boot from Flash (default)
22	WAKE_UP0*	I	J1-1*, TP1-2	0	Wake-Up 0 - optional J1 connection (R7 = UL)
23	WAKE_UP1*		J2-1*, TP1-3	0	Wake-Up 1 - optional J2 connection (R5 = UL)
24	GPIO24	I/O	TP1-4	1	General Purpose I/O 24
25	I2C1_SDA	I/O	J2-6	2	I ² C 1 SDA
26	I2C1_SCL	I/O	J2-5	2	I ² C 1 SCL
27	STRAP0	I/O	J3-2, TP1-5	1	Boot Mode: Short J3 = boot from UART; Disconnect J3 = boot from Flash (default)
39			TP1-6		Not configured
40	READY	O	LED1, TP1-7	0	LED1 is red (module ready indicator): On = initial power on reset; Fast Blink = corrupted flash image; Off = module initialized
41	LINK	O	LED2, TP1-8	0	LED2 is yellow (WLAN link indicator): On = initial power on reset; Slow Blink = provisioning mode (Soft AP); Fast Blink = associating to Access Point; Off = associated to Access Point
42	SSP1_CLK	I/O	J1-4	3	SSP 1 Serial Clock
43	SSP1_FRM	I/O	J1-3	3	SSP 1 Frame Indicator
44	SSP1_TXD	O	J1-5	3	SSP 1 TXD
45	SSP1_RXD	I	J1-6	3	SSP 1 RXD
46			TP2-9		Not configured
47			TP2-8		Not configured
48	UART2_TXD		J2-2*, TP2-7		UART 2 TXD (debug) – optional J2 connection (R6 = UL)
49	UART2_RXD		TP2-6		UART 2 RXD (debug)

“*”: GPIO/Signal not connected to header (mikroBUS J1 & J2; Boot Selector J3; ARM 10-pin J4)

5 Type ABR mikroBUS EVB Schematic and Layout

For more specifics on Type ABR EVB refer to **Figure 4: Type ABR mikroBUS EVB Schematic**, **Figure 5: Type ABR mikroBUS EVB Layout (top)**, and **Figure 6: Type ABR mikroBUS EVB Layout (bottom)**.

Figure 4: Type ABR mikroBUS EVB Schematic

ABR Mikrobus Module

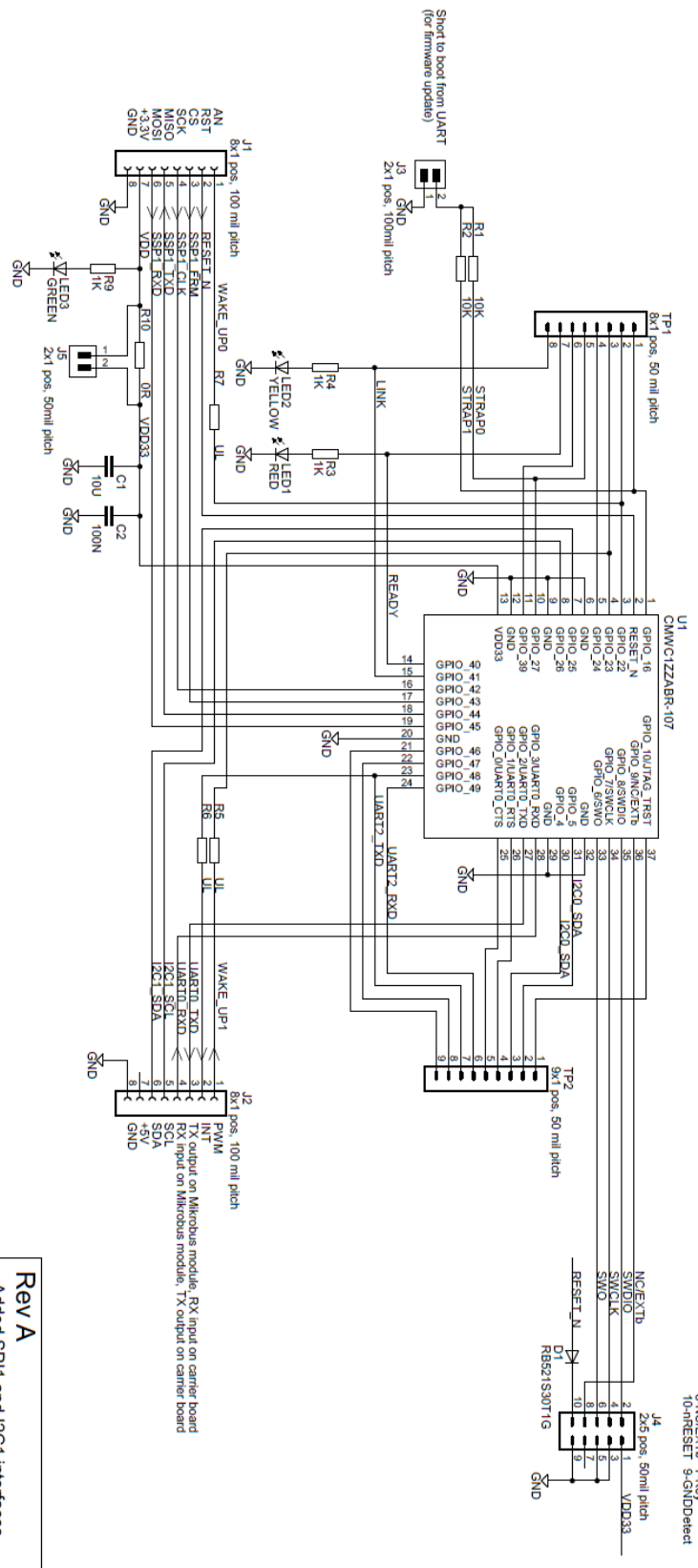

ARM 10-pin interface SWD Mode
10 pos (50 mil pitch) connector

- 2-SWDIO 1-VTref
- 4-SWCLK 3-GND
- 6-SWIO 5-GND
- 8-NC/EXTB 7-KEY
- 10-RESET 9-GND/Default

UL = Unloaded = normally not mounted component.

Default jumper settings are indicated in the schematic.
However, always check jumper positions on actual boards
since there is no guarantee that all jumpers are in default place.

Rev A	(C) Embedded Artists AB
Added SPI1 and I2C1 interfaces	
TITLE: CMWC1ZZABR-107-EVB rev A	
Document Number:	
Date: 2020-11-20 18:13:35	Sheet: 1/1

Figure 5: Type ABR mikroBUS EVB Layout (top)

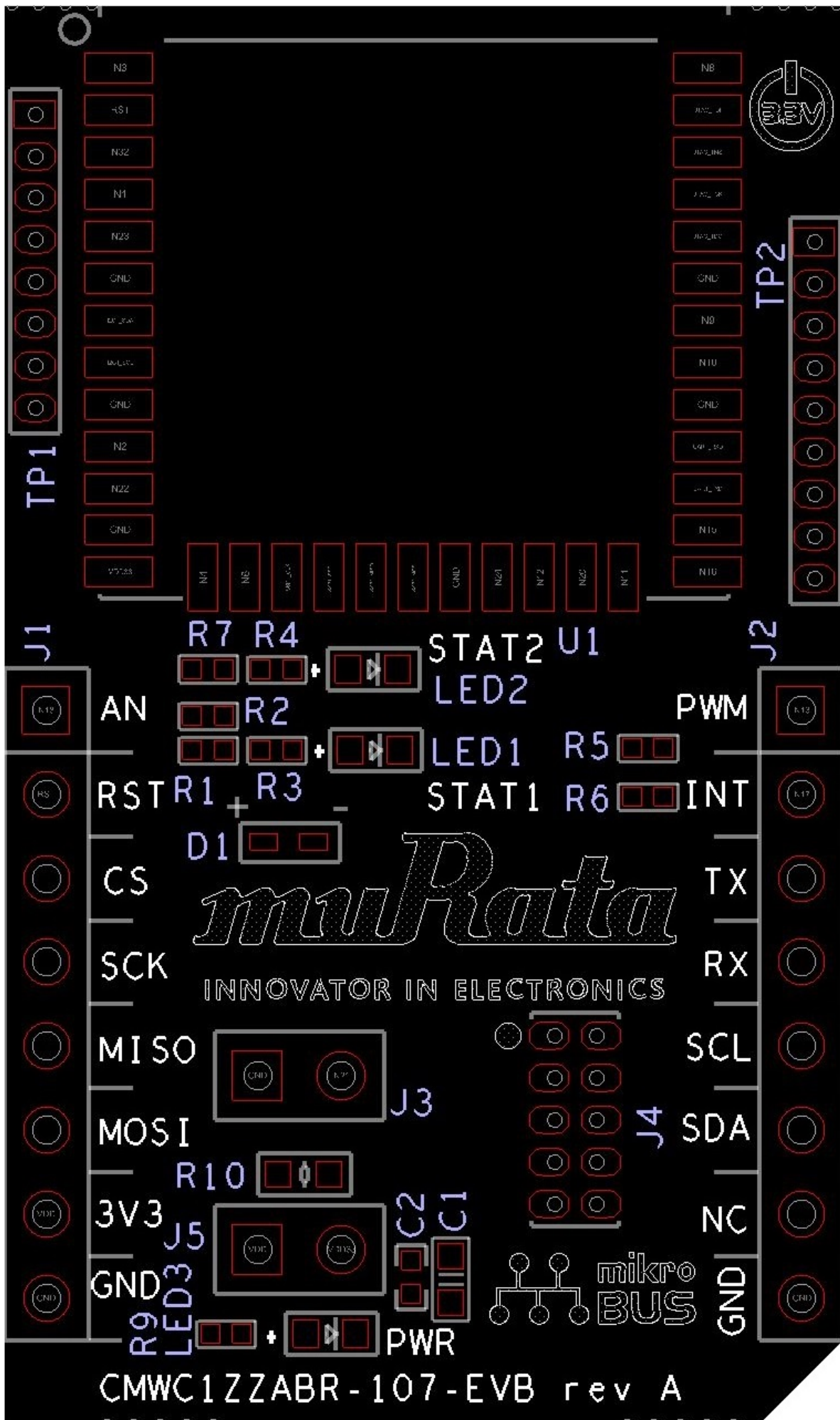
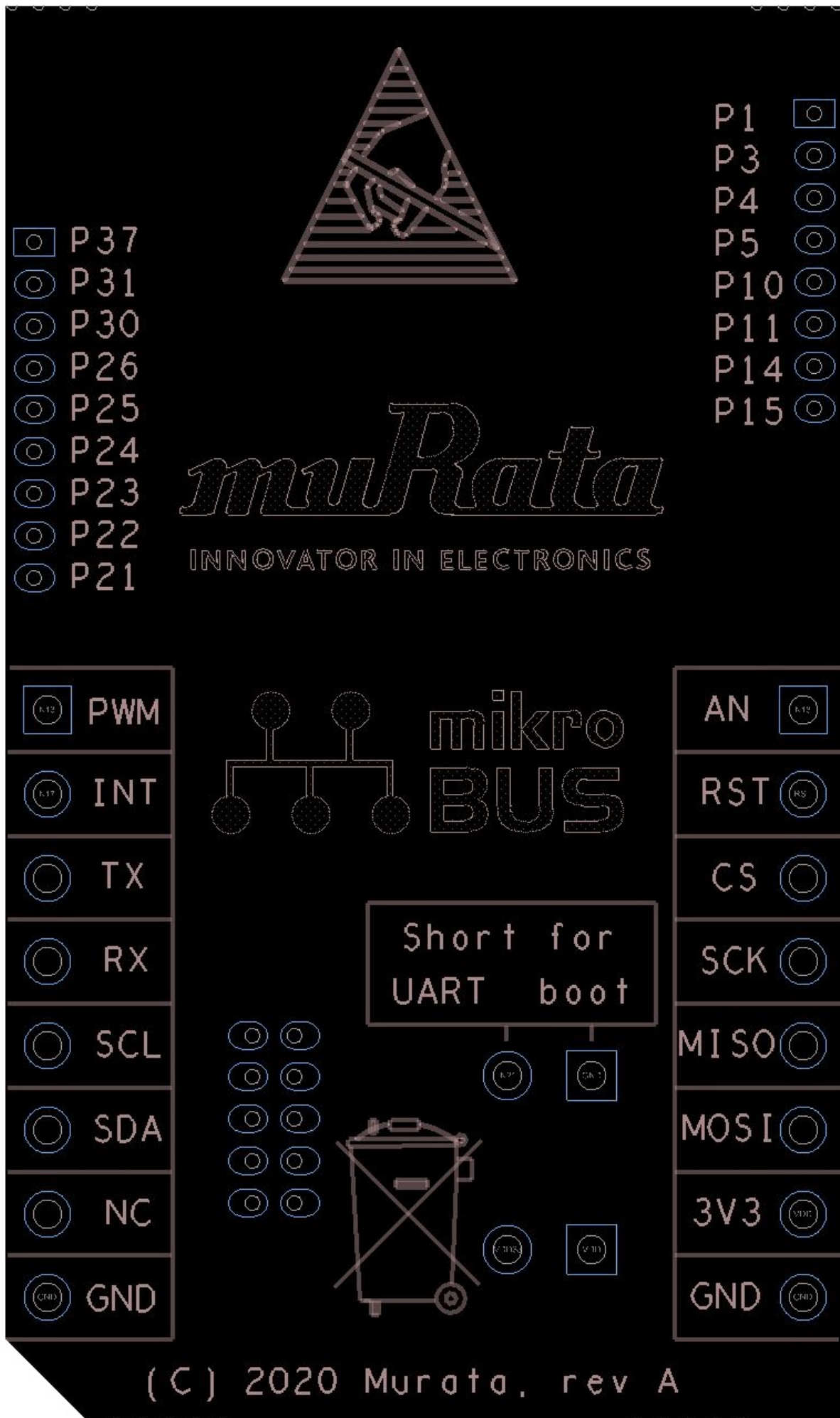

Figure 6: Type ABR mikroBUS EVB Layout (bottom)



6 Type ABR EVB Pre-flashed Firmware Image

6.1 Functionality Overview

Murata's Type ABR module has 2MB SPI flash onboard. This flash is pre-programmed on the Type ABR EVB with a Murata-customized version of NXP's WMSDKA "**serial_mwm_demo**" image. Customers may elect to re-flash the Type ABR module either to perform RF testing or customize their own WMSDKA implementation. Regarding more information on the pre-flashed image and how to flash the ABR EVB, refer to [Murata Type ABR mikroBUS Flashing Guide](#).

As documented in [Murata Type ABR mikroBUS EVB Quick Start Guide](#), Murata's Type ABR pre-flashed image allows plug-n-play interoperability with NXP's MCUXpresso solution on various platforms such as [LPC55S69-EVK](#).

"**serial_mwm_demo**" firmware provides an API to the interfacing NXP MCU (LPC, Kinetis, i.MX RT) so that Type ABR can support various modes such as:

- **Provisioning:** Type ABR is configured in Soft AP mode, allowing the User to associate over WLAN with another independent client. Type ABR is then configured to associate to a user-selected Access Point (wireless router).
- **Client/STA Mode:** Once provisioning is complete, then ABR will attempt association to the configured Access Point. Once associated, the ABR module will maintain the WLAN connection.

As shown in **Figure 7**, the READY and LINK LEDs (LED1 and LED2 respectively) indicate provisioning and client/STA mode. The functionality of these LED's is customized by Murata to assist the user in understanding what the ABR module is doing.

6.2 WMSDKA Background

WMSDKA stands for Wireless Microcontroller Software Development Kit. It is authored by NXP. The Wireless Microcontroller Software Development Kit WMSDKA (with support for Apple Development Kit) enables the development of custom firmware images that can be run on the processor built-into 88MW320 Single Chip Wi-Fi® Microcontroller. The wireless driver within the WMSDKA works in conjunction with the wireless firmware to provide the Wi-Fi® functionality. The Wi-Fi® firmware is stored on the flash of the development kit and is loaded into Wi-Fi® chipset during bootup.

The WMSDKA contains OS (FreeRTOS operating system), Networking Stack, Drivers, and Power Manager Framework. The WMSDKA Wi-Fi® driver supports the following features:

- Wi-Fi® Client/Station
- Access Point
- Wi-Fi® Connection Manager
- Wi-Fi® Power Management
- Wake-on-WLAN/Host Wakeup

For detailed information about WMSDKA, refer NXP's document, TN00067-Introducing-WMSDKA.pdf, present in WMSDKA documentation bundle (WMSDKA-V6.0.r7.p2-Documentation). For more details, refer to [NXP 88MW32X Landing Page](#).

7 Type ABR EVB LED Status

Murata customizes LED1/LED2 functionality in the “*serial_mwm_demo*” firmware which Type ABR EVB executes. **Table 4** and **Figure 7** provide comprehensive details below.

Table 4: LED1/LED2 Status during “serial_mwm_demo” execution

State	LED1 (Red) - READY	LED2 (Yellow) - LINK
Initial power on reset	ON	ON
Corrupted Flash Image	Fast Blink	ON
Provisioning Mode	OFF	Slow Blink
Associating to Access Point	OFF	Fast Blink
Associated to Access Point	OFF	OFF

Figure 7: LED1/LED2 Status Flow Diagram during “serial_mwm_demo” execution

