

## Product Information CAN Bus Transceiver – CF175

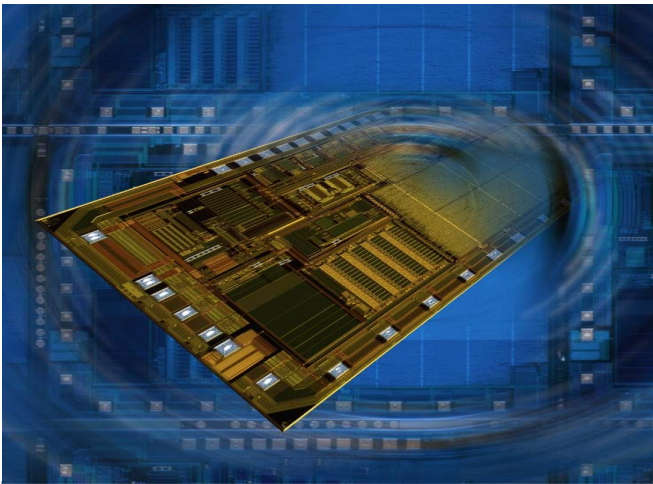

CAN Bus Transceiver

### Customer benefits:

- ▶ Excellent system know-how
- ▶ Smart concepts for system safety
- ▶ Secured supply
- ▶ Long- term availability of manufacturing processes and products
- ▶ QS9000 and ISO/TS16949 certified

The CF175 is a bidirectional transceiver for signal conditioning and processing in connection with a CAN controller.

### PIN Configuration

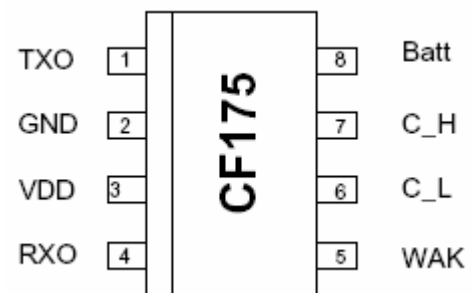

### Features

- ▶ General
  - Based on ISO 11898 standard
  - Data rates of up to 1Mbaud possible
  - Busvoltages 42V compatible
  - Compatible with 5V - CAN controller
  - RFI and EMI improved
  - Standby-mode ( VDD = 0 )
  - ESD- performance improved
- ▶ Transmitter
  - Differential output signals
  - Short-circuit-protection of C\_L, C\_H
  - TX dominant timeout
- ▶ Receiver
  - Differential input with high interference suppression
  - Common mode input voltage range from -5 V to 12 V
- ▶ Wakeup-detection
  - Differential input with high interference suppression
  - Common mode input voltage range wakeup from 0.3 V to 6 V
- ▶ Package: SOIC 8

### Pin Description

Pin	Name	Function
1	TXO	Transmitter input
2	GND	Ground
3	VDD	Supply (5V)
4	RXO	Receive output
5	WAK	Wakeup output
6	C_L	CAN bus low side
7	C_H	CAN bus high side
8	Batt	Standby supply

## Maximum ratings

All voltages, except bus voltage, are defined with respect to pin GND. Positive currents flow into the IC.

Rating	Condition	Symbol	Min.	Max.	Unit
1. Supply voltage (VDD)	static	V <sub>VDD</sub>	0	5.5	V
2. Supply voltage (VDD)	for less than a total of 5h over entire lifetime	V <sub>VDD</sub>	0	6	V
3. Supply voltage standby	for V <sub>Batt</sub> > 28V (e.g.42V-application) 1kOhm serial resistor necessary s. application note	V <sub>Batt</sub>	0	58	V
4. Bus voltage (C <sub>H</sub> ,C <sub>L</sub> )		V <sub>C<sub>H</sub></sub> , V <sub>C<sub>L</sub></sub>	-10V	V <sub>Batt</sub> +2V	
5. Voltage at TXO		V <sub>TXO</sub>	-0.3 V	V <sub>VDD</sub> +0.3V	
6. Output current at RXO		I <sub>RXO</sub>	-0.3	1	mA
7. Voltage at RXO		V <sub>RXO</sub>	-0.3 V	V <sub>VDD</sub> +0.3V	
8. Output current at WAK		- I <sub>WAK</sub>	-0.1	0.5	mA
9. Output voltage at WAK		V <sub>WAK</sub>	-0.3 V	V <sub>Batt</sub>	
10. Storage temperature		T <sub>ST</sub>	-40	150	°C
11. Ambient temperature		T <sub>amb</sub>	-40	125	°C
12. Junction temperature		T <sub>J</sub>	-40	150	°C
13. Electro static discharge voltage C <sub>H</sub> , C <sub>L</sub> to GND	Human Body Model 100pF, 1.5KOhm RX0=TX0=WAK= Batt = GND	V <sub>C<sub>H</sub></sub> , V <sub>C<sub>L</sub></sub>	-4	4	kV
14. Electro static discharge voltage RX0, TX0, WAK, VDD,Batt,C <sub>H</sub> , C <sub>L</sub> ,GND	Human Body Model 100pF, 1.5KOhm	V <sub>RX0</sub> , V <sub>TX0</sub> ,V <sub>WAK</sub> , V <sub>VDD</sub> ,V <sub>C<sub>H</sub></sub> , V <sub>C<sub>L</sub></sub> ,V <sub>Batt</sub>	-2	2	kV

## Characteristics

All voltages are defined with respect to pin GND. Positive currents flow into the IC.

If not otherwise defined the following conditions should be fulfilled:

-40×°C < T<sub>OP</sub> < 125°C and 4.75V < V<sub>VDD</sub> < 5.25V and 7.7V < V<sub>Batt</sub> < 42V

Dominant: both switches in the transmitter are conducting

Recessive: both switches in the transmitter are nonconducting

RL = Resistor between C<sub>H</sub> and C<sub>L</sub>

Rating	Conditions	Symbol	Min.	Typ.	Max.	Unit
Thermal resistance		R <sub>th j-amb</sub>		200		K/W
Voltage limit V <sub>Batt</sub> CAN function	no inversion of RX and BUS – signal	V <sub>Batt</sub>	5			V
Voltage limit V <sub>Batt</sub> Wakeup function		V <sub>Batt</sub>	7.7			V
Supply current VDD Dominant	Dominant, RL=60 Ohm	I <sub>VDD</sub>		50	80	mA
Supply current VDD Recessive	Recessive	I <sub>VDD</sub>		8	16	mA
Supply current VDD Short circuit to GND	Dominant V <sub>C<sub>H</sub></sub> = 0	I <sub>VDD</sub>		120		mA
Supply current Batt	-0.3V < V <sub>C<sub>L</sub></sub> -0.3V < V <sub>C<sub>H</sub></sub> I <sub>Batt.int</sub> = I <sub>Batt</sub> -  I <sub>wak</sub>   V <sub>Batt</sub> = 12V V <sub>Batt</sub> = 42V	I <sub>Batt.int</sub> I <sub>Batt.int</sub>			0.95 1.30	mA mA
Supply current Batt standby (VDD = 0 , no wakeup )	-0.3V < V <sub>C<sub>L</sub></sub> -0.3V < V <sub>C<sub>H</sub></sub> V <sub>Batt</sub> = 12V V <sub>Batt</sub> = 42V	I <sub>Batt</sub> I <sub>Batt</sub>		30 60	65 140	uA uA

## Transmitter section

Rating	Conditions	Symbol	Min.	Typ.	Max.	Unit
TXO Input capacitance	$0 < V_{TX0} < V_{VDD}$	$C_{TX0}$		5		pF
TXO High level input voltage		$V_{TX0}$	$0.45 V_{VDD}$		$V_{VDD}$	
TXO Low level input voltage		$V_{TX0}$	0		$0.17 V_{VDD}$	
TXO input current source	$0 < V_{TX0} < 0.45V_{VDD}$	$-I_{TX0}$	10	30	100	uA
Bus voltage recessive Poweron	Recessive $I_{C,L} = I_{C,H} = 0$	$V_{C,H}, V_{C,L}$	$0.4 V_{VDD}$		$0.6 V_{VDD}$	
Bus voltage recessive Standby	$V_{DD} = 0$ $I_{C,L} = I_{C,H} = 0$	$V_{C,H}, V_{C,L}$	0		1	V
Leakage current recessive	$0V < V_{C,L} < V_{VDD}, 0V < V_{C,H} < V_{VDD}$	$I_{C,H}, I_{C,L}$	-0.3		0.3	mA
Input resistance	Recessive or Standby $0V < V_{C,L} < V_{VDD}, 0V < V_{C,H} < V_{VDD}$	$R_{IN}$ ( $C_H, C_L$ )		20		kΩ
Differential input resistance	Recessive or Standby $0V < V_{C,L} < V_{VDD}, 0V < V_{C,H} < V_{VDD}$	$R_{Diff}$ ( $C_H, C_L$ )		40		kΩ
Differential output voltage dominant	Dominant, $RL = 60 \text{ Ohm}$	$V_{Diff} =$ $V_{C,H} - V_{C,L}$	1.5		3	V
Differential output voltage recessive	Recessive	$V_{Diff} =$ $V_{C,H} - V_{C,L}$	-200	0	50	mV
Output capacitance CH recessive	Recessive $1V < V_{C,H} < 3.5V$	$C_{C,H}$		13		pF
Output capacitance CL recessive	Recessive $1V < V_{C,L} < 3.5V$	$C_{C,L}$		7		pF

## Protection and Tx dominant timeout section

Rating	Conditions	Symbol	Min.	Typ.	Max.	Unit
TX dominant timeout time (transmitter switches off after $t_{dom}$ and TX0 = low)		$t_{dom}$	0.5	1	2	ms
Short circuit detection level (transmitter switches off if $V_{C,L} > V_{Short}$ or $V_{C,H} > V_{Short}$ )		$V_{Short}$	7	8.5	11	V

## Receiver section

Rating	Conditions	Symbol	Min.	Typ.	Max.	Unit
RXO High level output voltage $V_{Diff} = V_{C,H} - V_{C,L}$	$V_{Diff} < 0,4V$ $I_{RXO} = -0,3mA$ $-2V < V_{C,H} < 7V$ $-2V < V_{C,L} < 7V$	$V_{RXO}$	$0.9 V_{VDD}$		$V_{VDD}$	
RXO Low level output voltage $V_{Diff} = V_{C,H} - V_{C,L}$	$V_{Diff} > 1V$ $I_{RXO} = 1mA$ $-2V < V_{C,H} < 7V$ $-2V < V_{C,L} < 7V$	$V_{RXO}$	0		0.5	V
Input signal threshold $V_{Diff} = V_{C,H} - V_{C,L}$	$-2V < V_{C,H} < 7V$ $-2V < V_{C,L} < 7V$	$V_{Diff} / V_{VDD}$	0.106		0.171	
Differential input hysteresis $V_{Diff} = V_{C,H} - V_{C,L}$ $\Delta V_{Diff} = V_{Diff.high} - V_{Diff.low}$		$\Delta V_{Diff}$		120		mV

## Poweron and wakeup section

Rating	Conditions	Symbol	Min.	Typ.	Max.	Unit
Poweron level		$V_{VDD}$	2.9	3.5	4.2	V
Poweron hysteresis		$\Delta V_{VDD}$		0.2		V
Wakeup detection level Vwake	$-0.3 < V_{C\_L} < 6V$ $V_{DD} = 0$ $V_{wake} = V_{C\_H} - V_{C\_L}$	Vwake	400	800	1200	mV
Wakeup detection time (time required to detect wakeup)	$-0.3 < V_{C\_L} < 6V$ $V_{DD} = 0$ $V_{C\_H} - V_{C\_L} = 1.5V$	t <sub>WAK</sub>	0.5	2	3.5	ms
Wakeup timeout	$-0.3 < V_{C\_L} < 6V$ $V_{DD} = 0$	t <sub>Woff</sub>	128		512	ms
Wakeup output current ( on ) V <sub>Diff</sub> = V <sub>C_H</sub> - V <sub>C_L</sub> > Vwake	$-0.3 < V_{C\_L} < 6V$ $V_{Diff} > V_{wake}$ $V_{DD} = 0$ $V_{WAK} = V_{Batt} - 2V$	- I <sub>WAK</sub>	0.5			mA
Wakeup output current ( off ) V <sub>Diff</sub> = V <sub>C_H</sub> - V <sub>C_L</sub> < Vwake	$V_{Diff} < V_{wake}$ $V_{DD} = 0$ $0 < V_{WAK} < V_{Batt}$	I <sub>WAK</sub>	-10	0	10	μA

## Dynamic characteristics

General conditions:

C<sub>VDD</sub>: 47 pF between C<sub>H</sub> and C<sub>L</sub>, V<sub>VDD</sub> = 5V, V<sub>Batt</sub> = 14V, t<sub>r</sub> < 5ns

C<sub>RXO</sub>: 20 pF between RXO and GND, R<sub>L</sub>: =60 Ω

Rating	Conditions	Symbol	Min.	Typ.	Max.	Unit
Signal delay TX to C <sub>H</sub> ,C <sub>L</sub>		t <sub>r</sub>		80		ns
Differential output slew rate		dV <sub>Diff</sub> /dt		50		V/μs
Signal delay C <sub>H</sub> ,C <sub>L</sub> to RX		t <sub>r</sub>		50		ns
Signal delay TX to RX		t <sub>TR</sub>		130	210	ns

## Functional description

The CF175 is used as an interface between a CAN controller and the physical bus.

A TX dominant timeout function will switch off the transmitter if it is dominant for longer than  $t_{dom}$ .

A shortcircuit-protection will switch off the transmitter if  $V_{C\_L} > V_{Short}$  or  $V_{C\_H} > V_{Short}$ .

The standby-mode is achieved if VDD is set low while  $V_{Diff} < V_{wake}$ . In this mode the transmitter is off and the current-consumption at Batt is low.

During standby mode, a wakeup-signal ( $V_{Diff} > V_{wake}$  for  $t > t_{WAK}$ ) sets WAK to high level.

WAK will go to tristate again, after the wakeup timeout ( $t_{WOFF}$ ).

After the switch on of the standby-supply the WAK-output is in tristate until the first dominant-puls at the bus.

## Functional table

Bussignal CH_CL	VDD	mode	WAK
high	high	Poweron	tristate
low	high	Poweron	tristate
high	low	Standby	high plus
low	low	Standby	tristate

## Package: SOIC 8

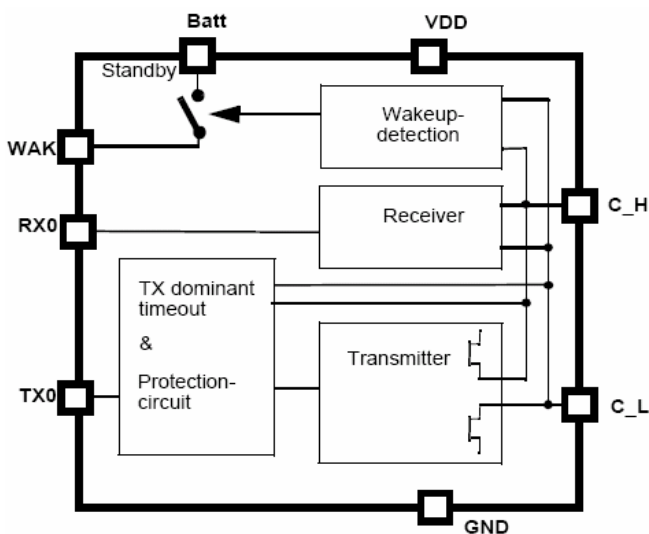

## Timing

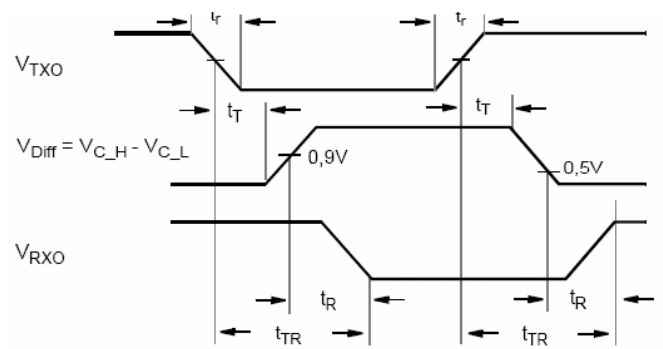

## Transition to standby- mode

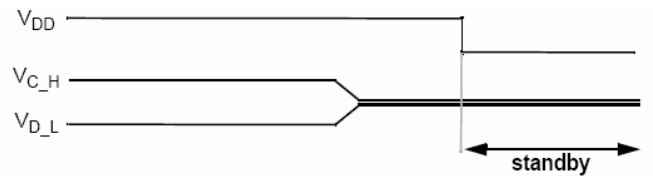

## Wakeup

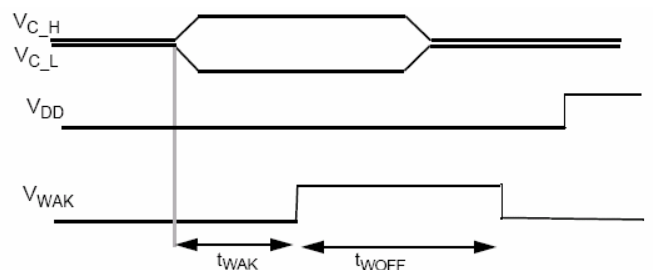

## TX Dominant timeout

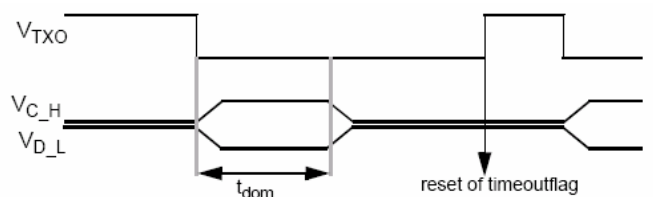

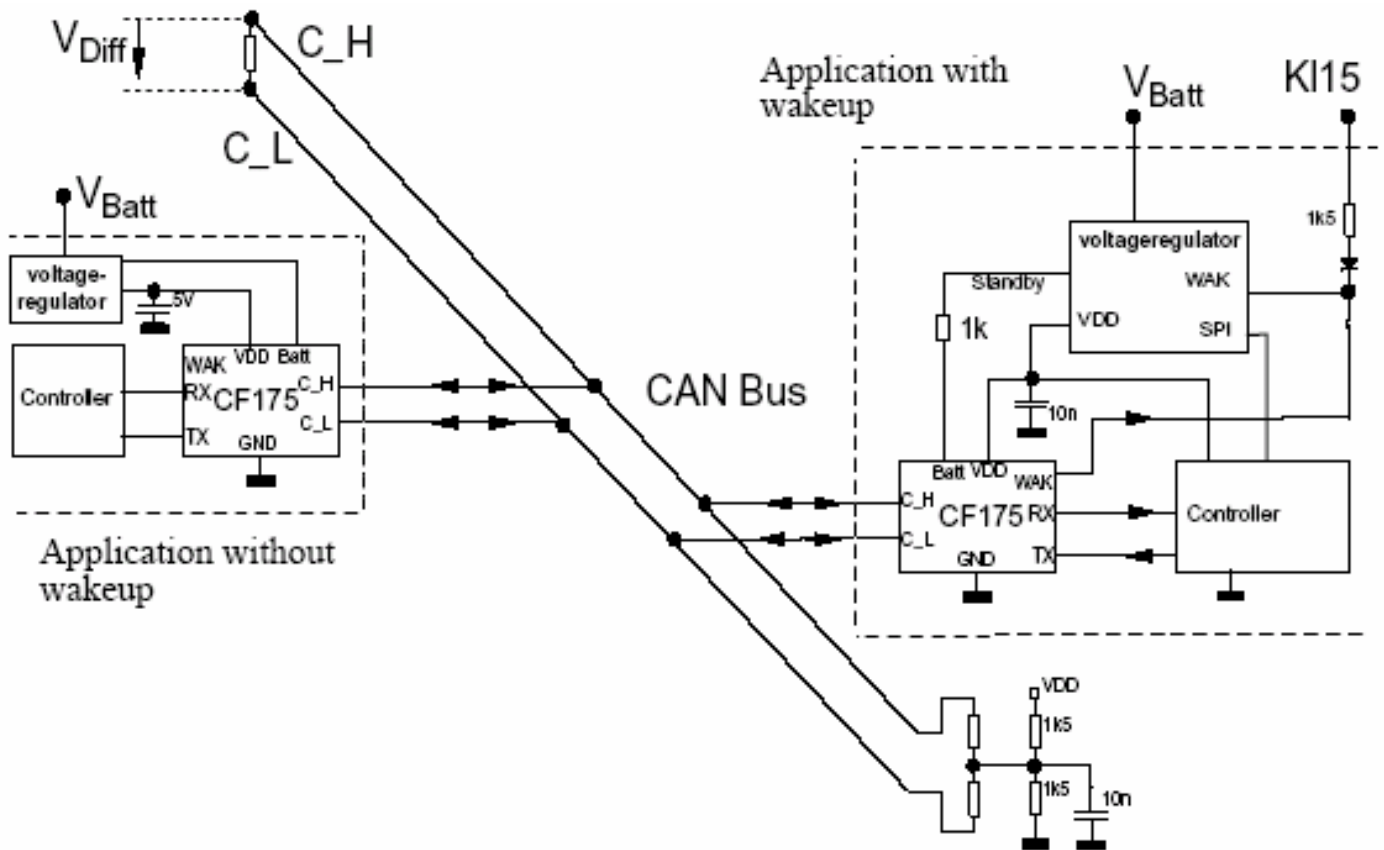

## Contact

**Robert Bosch GmbH**  
 Sales Semiconductors  
 Postbox 13 42  
 72703 Reutlingen  
**Germany**  
 Tel.: +49 7121 35-2979  
 Fax: +49 7121 35-2170

**Robert Bosch Corporation**  
 Component Sales  
 38000 Hills Tech Drive  
 Farmington Hills, MI 48331  
**USA**  
 Tel.: +1 248 876-7441  
 Fax: +1 248 848-2818

**Robert Bosch K.K.**  
 Component Sales  
 9-1, Ushikubo 3-chome  
 Tsuzuki-ku, Yokohama 224  
**Japan**  
 Tel.: +81 45 9 12-83 01  
 Fax: +81 45 9 12-95 73

E-Mail: [bosch.semiconductors@de.bosch.com](mailto:bosch.semiconductors@de.bosch.com)

Internet: [www.bosch-semiconductors.de](http://www.bosch-semiconductors.de)

© 02/2006 All rights reserved by Robert Bosch GmbH including the right to file industrial property rights  
 Robert Bosch GmbH retains the sole powers of distribution, such as reproduction, copying and distribution.

For any use of products outside the released application, specified environments or installation conditions no warranty shall apply and Bosch shall not be liable for such products or any damage caused by such products.