

LOC		DIST		REVISIONS			
GP	00	REV	DATE	BY	CHK	APPV	
U2	REVISED	PER	ECO-11-004835	11MAR11	RK	HMR	

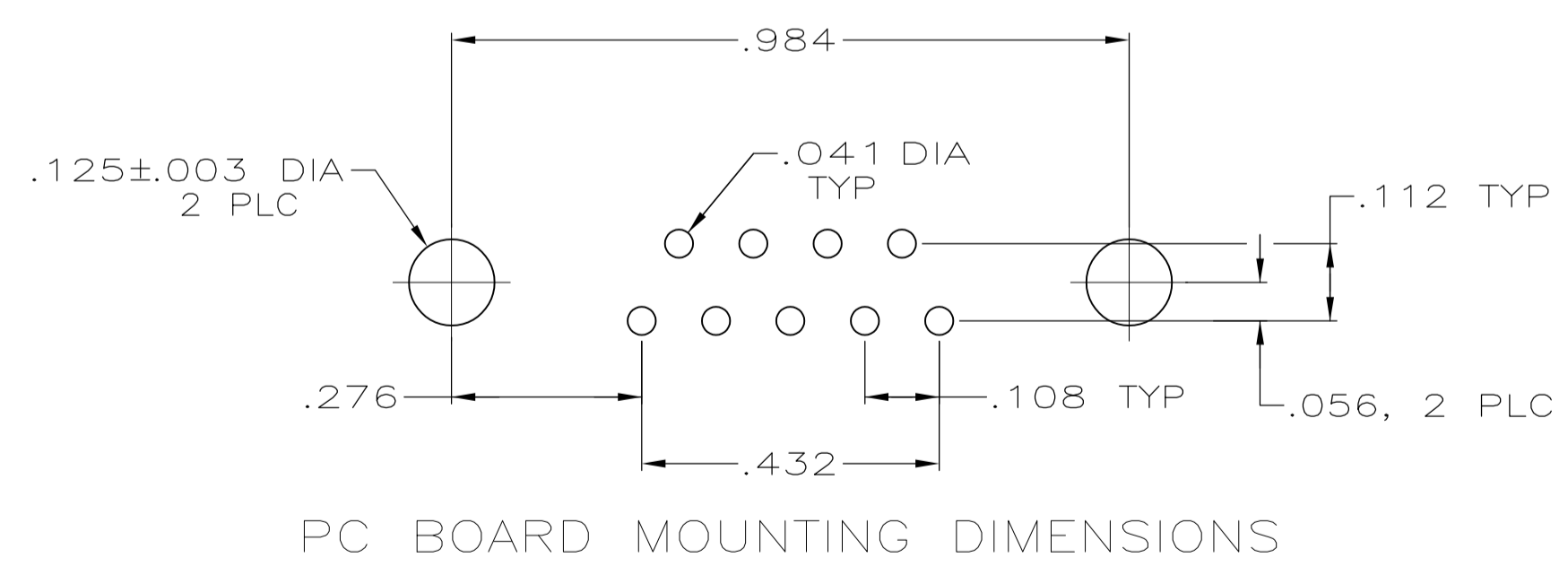
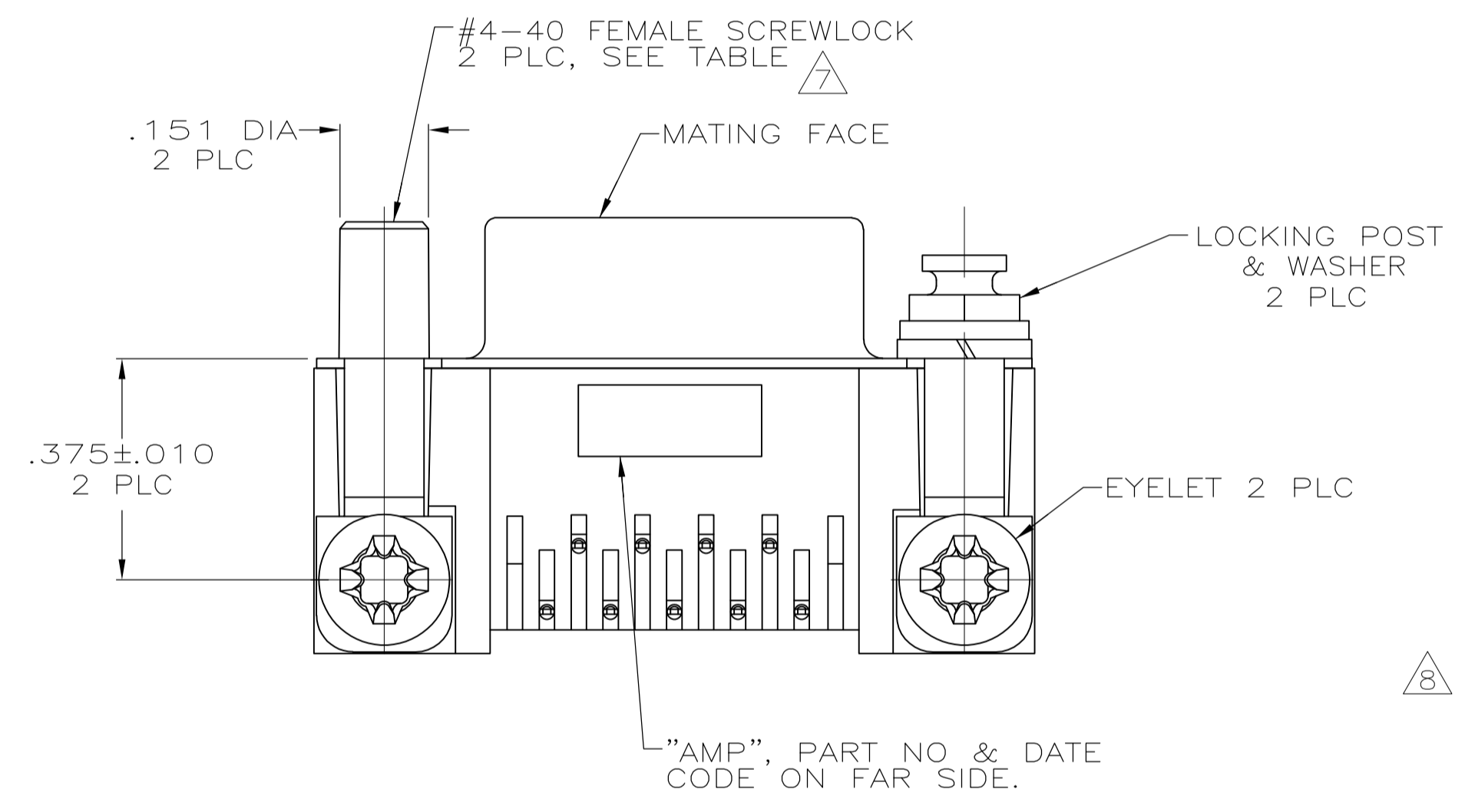
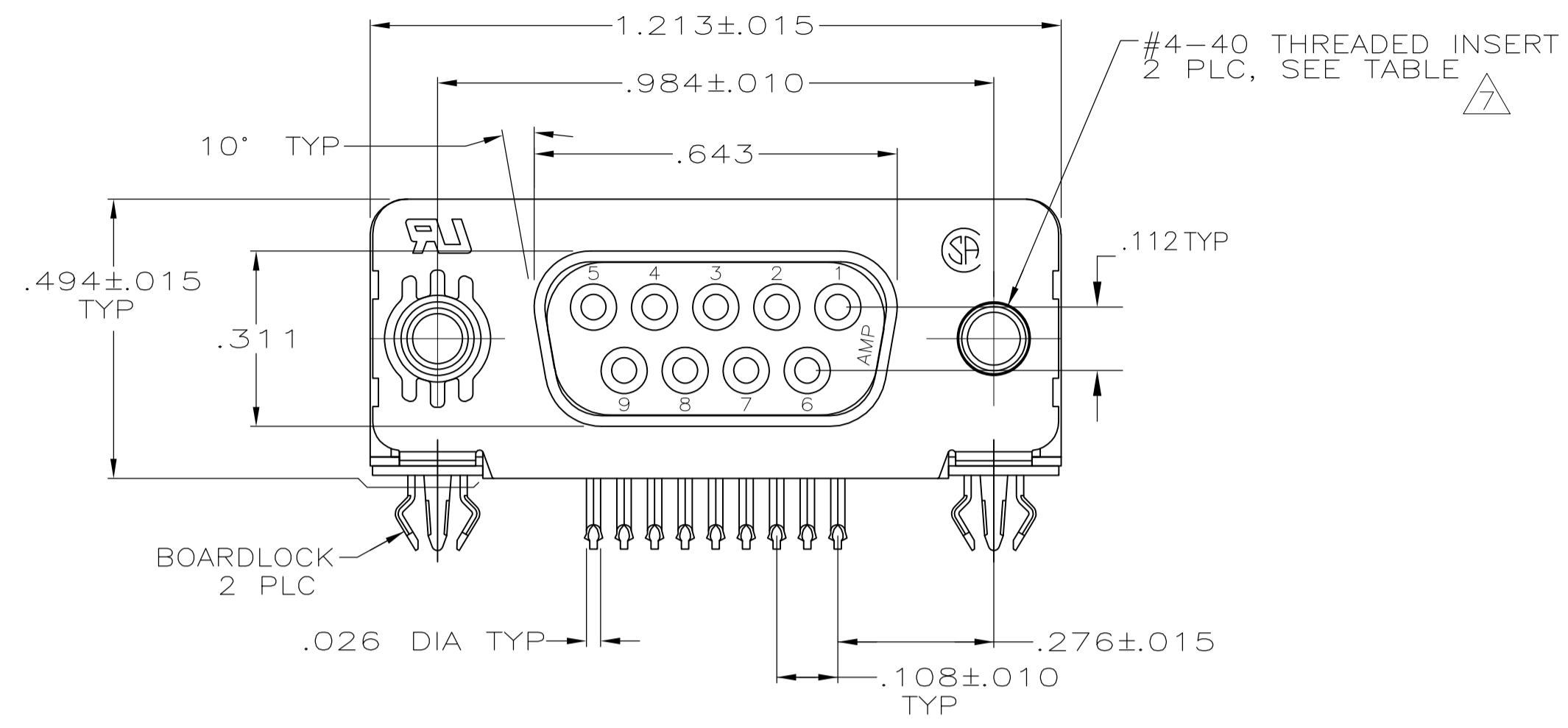

1. CONNECTOR MATES WITH ANY 9 POSN PLUG IN AMPLIMITE™ SERIES.
2. MOLDED PARTS: FLAME RETARDANT 94V-0 RATED THERMOPLASTIC, BLACK.  
SHELL: STEEL PER ASTM A109  
CONTACTS: PHOSPHOR BRONZE PER QQ-B-750  
EYELETS: BRASS  
SCREWLOCKS: ZINC  
INSERTS: ZINC  
BOARDLOCKS: COPPER ALLOY
3. SHELL: .000100 MIN TIN OR TIN-LEAD  
CONTACTS: SEE TABLE  
EYELETS: TIN  
SCREWLOCKS: CLEAR CHROMATE  
BOARDLOCKS: SEE TABLE  
INSERTS: CLEAR CHROMATE
4. GOLD PLATING PER MIL-G-45204, NICKEL PLATING PER QQ-N-290, TIN PLATING PER MIL-T-10727.
5. GOLD FLASH FOR A DISTANCE OF .100 MIN FROM MATING END, .000100-.000200 BRIGHT TIN OR BRIGHT TIN-LEAD ON TERMINATION END, ALL OVER .000050 NICKEL ON ENTIRE CONTACT.
6. .000030 GOLD FOR A DISTANCE OF .100 MIN FROM MATING END, .000100-.000200 BRIGHT TIN OR BRIGHT TIN-LEAD ON TERMINATION END, ALL OVER .000050 NICKEL ON ENTIRE CONTACT.
7. SCREWLOCKS & INSERTS WILL WITHSTAND 4 IN LBS TORQUE & 20 LBS PULL OUT FORCE FROM MATING FACE SIDE.
8. DIMENSION APPLIES TO CENTER LINE OF CONTACTS.
9. OBSOLETE PARTS: OBSOLETE CIS STREAMLINING PER D.RENAUD/D.SINISI

-	FEMALE SCREWLOCKS	TIN	6	7-747844-1
-	FEMALE SCREWLOCKS	TIN	5	7-747844-0
TRAY	THREADED INSERTS	TIN	6	6-747844-9
-	THREADED INSERTS	TIN	5	6-747844-8
-	.125 DIA HOLES	TIN	6	6-747844-7
SUPSD BY 747844-4	TUBE	THREADED INSERTS	TIN-LEAD	747844-8
SUPSD BY 747844-4	-	INSERT/LOCKING POST & WASHERS	TIN-LEAD	747844-7
-	FEMALE SCREWLOCKS	TIN-LEAD	6	747844-6
-	FEMALE SCREWLOCKS	TIN-LEAD	5	747844-5
TRAY	THREADED INSERTS	TIN-LEAD	6	747844-4
-	THREADED INSERTS	TIN-LEAD	5	747844-3
-	.125 DIA HOLES	TIN-LEAD	6	747844-2
SUPSD BY 747844-2	-	.125 DIA HOLES	TIN-LEAD	747844-1
PACKAGING	MOUNTING HARDWARE	BOARDLOCK FINISH	CONTACT FINISH	PART NUMBER

THIS DRAWING IS A CONTROLLED DOCUMENT.

DIMENSIONS: INCHES	TOLERANCES UNLESS OTHERWISE SPECIFIED:	DIN J. GALLUCCI BG 28 JAN 91	APVD W.G. LENKER 15 APR 91	NAME
0 PLC ± -	1 PLC ± -	2 PLC ± -	3 PLC ± .005	4 PLC ± -
ANGLES 2° ± -				
MATERIAL	FINISH	SIZE	WEIGHT	SCALE
		A1	00779	4:1

STE TE Connectivity

RECEPTACLE ASSEMBLY, SIZE 1, RIGHT ANGLE, .318 SERIES, FRONT METAL SHELL, .026 DIA POSTS, BOARDLOCKS, AMPLIMITE™ HD-20

APPLICATION SPEC 108-40025

SIZE 114-40010

WEIGHT -

CUSTOMER DRAWING

SCALE 4:1 SHEET 1 OF 1 REV U2