

REVISIONS

LTR	DESCRIPTION	DATE (YR-MO-DA)	APPROVED
A	Update the boilerplate to current requirements as specified in MIL-PRF-38535. Editorial changes throughout. – jak	06-12-06	Thomas M. Hess

REV																			
SHEET																			
REV																			
SHEET																			
REV STATUS	REV	A	A	A	A	A	A	A	A	A	A	A	A	A	A	A	A	A	
OF SHEETS	SHEET	1	2	3	4	5	6	7	8	9	10	11	12	13	14				

PMIC N/A	PREPARED BY Joseph A. Kerby	<p align="center"><b>DEFENSE SUPPLY CENTER COLUMBUS</b>  <b>COLUMBUS, OHIO 43218-3990</b>  <a href="http://www.dscclia.mil">http://www.dscclia.mil</a></p>													
<p align="center"><b>STANDARD MICROCIRCUIT DRAWING</b></p> <p>THIS DRAWING IS AVAILABLE FOR USE BY ALL DEPARTMENTS AND AGENCIES OF THE DEPARTMENT OF DEFENSE</p> <p align="center">AMSC N/A</p>	CHECKED BY Thomas J. Ricciuti														
	APPROVED BY Joseph A. DuPay	<p>MICROCIRCUIT, DIGITAL, FAST CMOS, 1-OF-8 DECODER WITH ENABLE, TTL COMPATIBLE INPUTS AND LIMITED OUTPUT VOLTAGE SWING, MONOLITHIC SILICON</p>													
	DRAWING APPROVAL DATE 93-06-29														
	REVISION LEVEL A		<table border="1"> <tr> <td>SIZE <b>A</b></td> <td>CAGE CODE <b>67268</b></td> <td><b>5962-92233</b></td> </tr> </table>	SIZE <b>A</b>	CAGE CODE <b>67268</b>	<b>5962-92233</b>									
SIZE <b>A</b>	CAGE CODE <b>67268</b>	<b>5962-92233</b>													
		SHEET	1 OF 14												

1.1 Scope. This drawing documents two product assurance class levels consisting of high reliability (device classes M and Q) and space application (device class V). A choice of case outlines and lead finishes are available and are reflected in the Part or Identifying Number (PIN). When available, a choice of radiation hardness assurance (RHA) levels are reflected in the PIN.

1.2 PIN. The PIN is as shown in the following example:

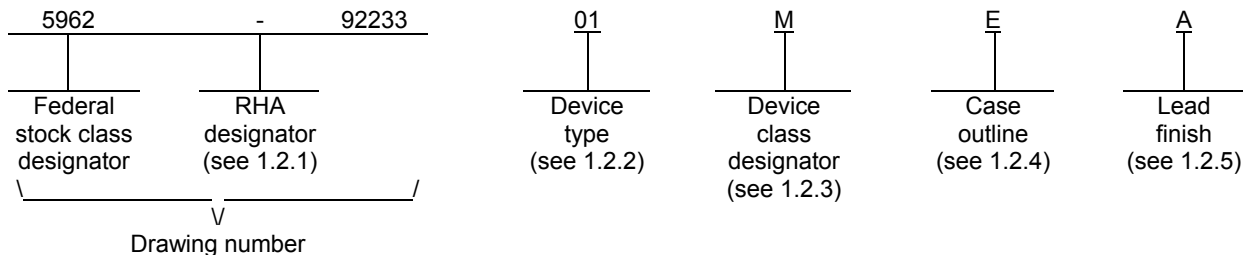

1.2.1 RHA designator. Device classes Q and V RHA marked devices meet the MIL-PRF-38535 specified RHA levels and are marked with the appropriate RHA designator. Device class M RHA marked devices meet the MIL-PRF-38535, appendix A specified RHA levels and are marked with the appropriate RHA designator. A dash (-) indicates a non-RHA device.

1.2.2 Device type(s). The device type(s) identify the circuit function as follows:

<u>Device type</u>	<u>Generic number</u>	<u>Circuit function</u>
01, 02	54FCT138T	1-of-8 decoder with enable, TTL compatible inputs and limited output voltage swing
03, 04	54FCT138AT	1-of-8 decoder with enable, TTL compatible inputs and limited output voltage swing
05, 06	54FCT138CT	1-of-8 decoder with enable, TTL compatible inputs and limited output voltage swing

1.2.3 Device class designator. The device class designator is a single letter identifying the product assurance level as follows:

<u>Device class</u>	<u>Device requirements documentation</u>
M	Vendor self-certification to the requirements for MIL-STD-883 compliant, non-JAN class level B microcircuits in accordance with MIL-PRF-38535, appendix A
Q or V	Certification and qualification to MIL-PRF-38535

1.2.4 Case outline(s). The case outline(s) are as designated in MIL-STD-1835 and as follows:

<u>Outline letter</u>	<u>Descriptive designator</u>	<u>Terminals</u>	<u>Package style</u>
E	GDIP1-T16 or CDIP2-T16	16	Dual-in-line
F	GDFP2-F16 or CDFP3-F16	16	Flat pack
2	CQCC1-N20	20	Square leadless chip carrier

1.2.5 Lead finish. The lead finish is as specified in MIL-PRF-38535 for device classes Q and V or MIL-PRF-38535, appendix A for device class M.

<b>STANDARD MICROCIRCUIT DRAWING</b> DEFENSE SUPPLY CENTER COLUMBUS COLUMBUS, OHIO 43218-3990	SIZE <b>A</b>		<b>5962-92233</b>
		REVISION LEVEL A	SHEET <b>2</b>

1.3 Absolute maximum ratings. 1/ 2/ 3/

Supply voltage range ( $V_{CC}$ )	-0.5 V dc to +7.0 V dc
DC input voltage range ( $V_{IN}$ )	-0.5 V dc to $V_{CC} + 0.5$ V dc 4/
DC output voltage range ( $V_{OUT}$ )	-0.5 V dc to $V_{CC} + 0.5$ V dc 4/
DC input clamp current ( $I_{IK}$ ) ( $V_{IN} = -0.5$ V)	-20 mA
DC output clamp current ( $I_{OK}$ ) ( $V_{OUT} = -0.5$ V and +7.0 V)	$\pm 20$ mA
DC output source current (per output) ( $I_{OH}$ )	-30 mA
DC output sink current (per output) ( $I_{OL}$ )	+70 mA
DC $V_{CC}$ current ( $I_{CC}$ )	$\pm 252$ mA
DC GND current ( $I_{GND}$ )	+572 mA
Storage temperature range ( $T_{STG}$ )	-65°C to +150°C
Case temperature range under bias ( $T_{BIAS}$ )	-65°C to +135°C
Maximum power dissipation ( $P_D$ )	500 mW
Lead temperature (soldering, 10 seconds)	+300°C
Thermal resistance, junction-to-case ( $\theta_{JC}$ )	See MIL-STD-1835
Junction temperature ( $T_J$ )	+175°C

1.4 Recommended operating conditions 2/ 3/

Supply voltage range ( $V_{CC}$ )	+4.5 V dc to +5.5 V dc
Input voltage range ( $V_{IN}$ )	0.0 V to $V_{CC}$
Output voltage range ( $V_{OUT}$ )	0.0 V to $V_{CC}$
Maximum low level input voltage ( $V_{IL}$ )	0.8 V
Minimum high level input voltage ( $V_{IH}$ )	2.0 V
Case operating temperature range ( $T_C$ )	-55°C to +125°C
Maximum input rise or fall rate ( $t_r, t_f$ ): (from $V_{IN} = 0.3$ V to 2.7 V, 2.7 V to 0.3 V)	5 ns/V
Maximum high level output current ( $I_{OH}$ ): Devices 01, 03, and 05	-12 mA
Devices 02, 04, and 06	-6 mA
Maximum low level output current ( $I_{OL}$ )	32 mA

1/ Stresses above the absolute maximum rating may cause permanent damage to the device. Extended operation at the maximum levels may degrade performance and affect reliability.

2/ Unless otherwise noted, all voltages are referenced to GND.

3/ The limits for the parameters specified shall apply over the full specified  $V_{CC}$  range and case temperature range of -55°C to +125°C.

4/ For  $V_{CC} \geq 6.5$  V, the upper limit on the range is limited to 7.0 V.

<b>STANDARD MICROCIRCUIT DRAWING</b> DEFENSE SUPPLY CENTER COLUMBUS COLUMBUS, OHIO 43218-3990	SIZE <b>A</b>		<b>5962-92233</b>
		REVISION LEVEL A	SHEET <b>3</b>

## 2. APPLICABLE DOCUMENTS

2.1 Government specification, standards, and handbooks. The following specification, standards, and handbooks form a part of this drawing to the extent specified herein. Unless otherwise specified, the issues of these documents are those cited in the solicitation or contract.

### DEPARTMENT OF DEFENSE SPECIFICATION

MIL-PRF-38535 - Integrated Circuits, Manufacturing, General Specification for.

### DEPARTMENT OF DEFENSE STANDARDS

MIL-STD-883 - Test Method Standard Microcircuits.

MIL-STD-1835 - Interface Standard Electronic Component Case Outlines.

### DEPARTMENT OF DEFENSE HANDBOOKS

MIL-HDBK-103 - List of Standard Microcircuit Drawings.

MIL-HDBK-780 - Standard Microcircuit Drawings.

(Copies of these documents are available online at <http://assist.daps.dla.mil/quicksearch/> or <http://assist.daps.dla.mil> or from the Standardization Document Order Desk, 700 Robbins Avenue, Building 4D, Philadelphia, PA 19111-5094.)

2.2 Order of precedence. In the event of a conflict between the text of this drawing and the references cited herein, the text of this drawing takes precedence. Nothing in this document, however, supersedes applicable laws and regulations unless a specific exemption has been obtained.

## 3. REQUIREMENTS

3.1 Item requirements. The individual item requirements for device classes Q and V shall be in accordance with MIL-PRF-38535 and as specified herein or as modified in the device manufacturer's Quality Management (QM) plan. The modification in the QM plan shall not affect the form, fit, or function as described herein. The individual item requirements for device class M shall be in accordance with MIL-PRF-38535, appendix A for non-JAN class level C devices and as specified herein.

3.2 Design, construction, and physical dimensions. The design, construction, and physical dimensions shall be as specified in MIL-PRF-38535 and herein for device classes Q and V or MIL-PRF-38535, appendix A and herein for device class M.

3.2.1 Case outlines. The case outlines shall be in accordance with 1.2.2 herein.

3.2.2 Terminal connections. The terminal connections shall be as specified on figure 1.

3.2.3 Truth table. The truth table shall be as specified on figure 2.

3.2.4 Logic diagram. The logic diagram shall be as specified on figure 3.

3.2.6 Switching waveforms and test circuit. The switching waveforms and test circuit shall be as specified on figure 4.

3.3 Electrical performance characteristics and postirradiation parameter limits. Unless otherwise specified herein, the electrical performance characteristics and postirradiation parameter limits are as specified in table I and shall apply over the full case operating temperature range. Test conditions for these specified characteristics and limits are as specified in table I.

3.4 Electrical test requirements. The electrical test requirements shall be the subgroups specified in table II. The electrical tests for each subgroup are defined in table I.

<b>STANDARD MICROCIRCUIT DRAWING</b> DEFENSE SUPPLY CENTER COLUMBUS COLUMBUS, OHIO 43218-3990	SIZE <b>A</b>		<b>5962-92233</b>
		REVISION LEVEL A	SHEET <b>4</b>

3.5 Marking. The part shall be marked with the PIN listed in 1.2 herein. In addition, the manufacturer's PIN may also be marked. For packages where marking of the entire SMD PIN number is not feasible due to space limitations, the manufacturer has the option of not marking the "5962-" on the device. For RHA product using this option, the RHA designator shall still be marked. Marking for device classes Q and V shall be in accordance with MIL-PRF-38535. Marking for device class M shall be in accordance with MIL-PRF-38535, appendix A.

3.5.1 Certification/compliance mark. The certification mark for device classes Q and V shall be a "QML" or "Q" as required in MIL-PRF-38535. The compliance mark for device class M shall be a "C" as required in MIL-PRF-38535, appendix A.

3.6 Certificate of compliance. For device classes Q and V, a certificate of compliance shall be required from a QML-38535 listed manufacturer in order to supply to the requirements of this drawing (see 6.6.1 herein). For device class M, a certificate of compliance shall be required from a manufacturer in order to be listed as an approved source of supply in MIL-HDBK-103 (see 6.6.2 herein). The certificate of compliance submitted to DSCC-VA prior to listing as an approved source of supply for this drawing shall affirm that the manufacturer's product meets, for device classes Q and V, the requirements of MIL-PRF-38535 and herein or for device class M the requirements of MIL-PRF-38535, appendix A and herein.

3.7 Certificate of conformance. A certificate of conformance as required for device classes Q and V in MIL-PRF-38535 or for device class M in MIL-PRF-38535, appendix A shall be provided with each lot of microcircuits delivered to this drawing.

3.8 Notification of change for device class M. For device class M notification to DSCC-VA of change of product (see 6.2 herein) involving devices acquired to this drawing is required for any change that affects this drawing.

3.9 Verification and review for device class M. For device class M, DSCC, DSCC's agent, and the acquiring activity retain the option to review the manufacturer's facility and applicable required documentation. Offshore documentation shall be made available onshore at the option of the reviewer.

3.10 Microcircuit group assignment for device class M. Device class M devices covered by this drawing shall be in microcircuit group number 39 (see MIL-PRF-38535, appendix A).

<b>STANDARD MICROCIRCUIT DRAWING</b> DEFENSE SUPPLY CENTER COLUMBUS COLUMBUS, OHIO 43218-3990	SIZE <b>A</b>		<b>5962-92233</b>
		REVISION LEVEL A	SHEET <b>5</b>

TABLE I. Electrical performance characteristics.

Test and MIL-STD-883 test method <u>1/</u>	Symbol	Conditions <u>2/</u> -55°C ≤ T <sub>C</sub> ≤ +125°C 4.5 V ≤ V <sub>CC</sub> ≤ 5.5 V unless otherwise specified	Device type	V <sub>CC</sub>	Group A subgroups	Limits <u>3/</u>		Unit
						Min	Max	
High level output voltage 3006	V <sub>OH1</sub> <u>4/</u>	For all inputs affecting output under test, V <sub>IN</sub> = V <sub>IH</sub> or V <sub>IL</sub> V <sub>IL</sub> = 0.8 V V <sub>IH</sub> = 2.0 V For all other inputs, V <sub>IN</sub> = V <sub>CC</sub> or GND I <sub>OH</sub> = -300 μA	01, 03, 05	4.5 V	1, 2, 3	3.0	V <sub>CC</sub> - 0.5	V
			02, 04, 06			2.7	V <sub>CC</sub> - 0.5	
	V <sub>OH2</sub>	For all inputs affecting output under test, V <sub>IN</sub> = V <sub>IH</sub> or V <sub>IL</sub> V <sub>IL</sub> = 0.8 V V <sub>IH</sub> = 2.0 V For all other inputs, V <sub>IN</sub> = V <sub>CC</sub> or GND	I <sub>OH</sub> = -12 mA 01, 03, 05	4.5 V	1, 2, 3	2.4	V <sub>CC</sub> - 0.5	V
		I <sub>OH</sub> = -6 mA 02, 04, 06			2.4	V <sub>CC</sub> - 0.5		
					2.0	V <sub>CC</sub> - 0.5		
Low level output voltage 3007	V <sub>OL1</sub> <u>4/</u>	For all inputs affecting output under test, V <sub>IN</sub> = V <sub>IH</sub> or V <sub>IL</sub> V <sub>IL</sub> = 0.8 V V <sub>IH</sub> = 2.0 V For all other inputs, V <sub>IN</sub> = V <sub>CC</sub> or GND I <sub>OL</sub> = 300 μA	All	4.5 V	1, 2, 3		0.20	V
	V <sub>OL2</sub>	For all inputs affecting output under test, V <sub>IN</sub> = V <sub>IH</sub> or V <sub>IL</sub> V <sub>IL</sub> = 0.8 V V <sub>IH</sub> = 2.0 V For all other inputs, V <sub>IN</sub> = V <sub>CC</sub> or GND I <sub>OL</sub> = 32 mA	All	4.5 V	1, 2, 3		0.55	
Negative input clamp voltage 3022	V <sub>IC-</sub>	For input under test, I <sub>IN</sub> = -15 mA	01, 03, 05	4.5 V	1, 2, 3		-1.3	V
			02, 04, 06				-1.2	
High level input current 3010	I <sub>IH</sub>	For input under test, V <sub>IN</sub> = V <sub>CC</sub> For all other inputs, V <sub>IN</sub> = V <sub>CC</sub> or GND	01, 03, 05	5.5 V	1		0.1	μA
					2, 3		1.0	
			02, 04, 06		1, 2		1.0	
					3		5.0	
Low level input current 3009	I <sub>IL</sub>	For input under test, V <sub>IN</sub> = GND For all other inputs, V <sub>IN</sub> = V <sub>CC</sub> or GND	01, 03, 05	5.5 V	1		-0.1	μA
					2, 3		-1.0	
			02, 04, 06		1, 2		-1.0	
					3		-5.0	

See footnotes at end of table.

<b>STANDARD MICROCIRCUIT DRAWING</b> DEFENSE SUPPLY CENTER COLUMBUS COLUMBUS, OHIO 43218-3990	SIZE <b>A</b>		<b>5962-92233</b>
		REVISION LEVEL A	SHEET <b>6</b>

TABLE I. Electrical performance characteristics – Continued.

Test and MIL-STD-883 test method <u>1/</u>	Symbol	Conditions <u>2/</u> -55°C ≤ T <sub>C</sub> ≤ +125°C 4.5 V ≤ V <sub>CC</sub> ≤ 5.5 V unless otherwise specified		Device type	V <sub>CC</sub>	Group A subgroups	Limits <u>3/</u>		Unit
							Min	Max	
Input capacitance 3012	C <sub>IN</sub> <u>5/</u>	See 4.3.1b T <sub>C</sub> = +25°C		All	GND	4		10	pF
Output capacitance 3012	C <sub>OUT</sub> <u>5/</u>	See 4.3.1b		All	GND	4		12	pF
Short circuit output current 3005	I <sub>OS</sub> <u>6/</u>	For all inputs, V <sub>IN</sub> = V <sub>CC</sub> or GND V <sub>OUT</sub> = GND		All	5.5 V	1, 2, 3	-60	-225	mA
Dynamic power supply current	I <sub>CCD</sub> <u>4/ 7/</u>	Outputs open		01, 03, 05	5.5 V	4, 5, 6		0.25	mA/ MHz• Bit
				02, 04, 06				0.30	
Quiescent power supply current delta (TTL input levels) 3005	ΔI <sub>CC</sub> <u>8/</u>	For input under test, V <sub>IN</sub> = V <sub>CC</sub> - 2.1 V For all other inputs, V <sub>IN</sub> = V <sub>CC</sub> or GND		All	5.5 V	1, 2, 3		2.0	mA
Quiescent power supply current output high 3005	I <sub>CCH</sub>	E1 = E2 = GND, E3 = V <sub>CC</sub> For all other inputs, V <sub>IN</sub> = V <sub>CC</sub> or GND		All	5.5 V	1, 2, 3		1.5	mA
Quiescent power supply current output low 3005	I <sub>CCL</sub>	E1 = E2 = GND, E3 = V <sub>CC</sub> For all other inputs, V <sub>IN</sub> = V <sub>CC</sub> or GND		All	5.5 V	1, 2, 3		1.5	mA
Total power supply current	I <sub>CCT</sub> <u>9/</u>	Outputs open E1, E2, or E3 toggling One bit toggling f <sub>i</sub> = 10 MHz 50% duty cycle For nonswitching inputs V <sub>IN</sub> = V <sub>CC</sub> or GND	For switching inputs V <sub>IN</sub> = V <sub>CC</sub> or GND	01, 03, 05	5.5 V	4, 5, 6		4.0	mA
				02, 04, 06				4.5	
				01, 03, 05				5.0	
				02, 04, 06				5.5	
Functional tests	<u>10/</u>	V <sub>IL</sub> = 0.8 V V <sub>IH</sub> = 2.0 V Verify output V <sub>O</sub> See 4.3.1c		All	4.5 V	7, 8	L	H	
				All	5.5 V	7, 8	L	H	
Propagation delay time, Am to On 3003	t <sub>PLH1</sub> , t <sub>PHL1</sub> <u>11/</u>	C <sub>L</sub> = 50 pF minimum R <sub>L</sub> = 500Ω See figure 4		01, 02	4.5 V	9, 10, 11	1.5	12.0	ns
				03, 04			1.5	7.8	
				05, 06			1.5	6.0	
Propagation delay time, E1 or E2 to On 3003	t <sub>PLH2</sub> , t <sub>PHL2</sub> <u>11/</u>			01, 02	4.5 V	9, 10, 11	1.5	12.5	ns
				03, 04			1.5	8.0	
				05, 06			1.5	6.1	
Propagation delay time, E3 to On 3003	t <sub>PLH3</sub> , t <sub>PHL3</sub> <u>11/</u>			01, 02	4.5 V	9, 10, 11	1.5	12.5	ns
				03, 04			1.5	8.0	
				05, 06			1.5	6.1	

See footnotes on next sheet.

<b>STANDARD MICROCIRCUIT DRAWING</b> DEFENSE SUPPLY CENTER COLUMBUS COLUMBUS, OHIO 43218-3990	SIZE <b>A</b>		<b>5962-92233</b>
		REVISION LEVEL A	SHEET <b>7</b>

TABLE I. Electrical performance characteristics - Continued.

- 1/ For tests not listed in the referenced MIL-STD-883 (e.g.  $\Delta I_{CC}$ ), utilize the general test procedure under the conditions listed herein.
- 2/ Each input/output, as applicable shall be tested at the specified temperature for the specified limits to the tests in table I herein. Output terminals not designated shall be high level logic, low level logic, or open, except for all  $I_{CC}$  and  $\Delta I_{CC}$  tests, the output terminal(s) shall be open. When performing these tests, the current meter shall be placed in the circuit such that all current flows through the meter
- 3/ For negative and positive voltage and current values, the sign designates the potential difference in reference to GND and the direction of current flow, respectively; and the absolute value of the magnitude, not the sign, is relative to the minimum and maximum limits, as applicable, listed herein. All devices shall meet or exceed the limits specified in table I at  $4.5 V \leq V_{CC} \leq 5.5 V$ .
- 4/ This parameter is guaranteed, if not tested, to the limits specified in table I.
- 5/ This test is required only for group A testing, see 4.4.1 herein.
- 6/ Not more than one output should be shorted at a time. The duration of the short circuit test should not exceed on second.
- 7/  $I_{CCD}$  may be verified by the following equation:  

$$I_{CCD} = \frac{I_{CCT} - I_{CC} - D_H N_T \Delta I_{CC}}{f_{CP}/2 + f_i N_i}$$

Where,  $I_{CCT}$ , ( $I_{CC}$  or  $I_{CCH}$  in table I), and  $\Delta I_{CC}$  shall be the measured values of these parameters, for the device under test, when tested as described in table I, herein. The values for  $D_H$ ,  $N_T$ ,  $f_{CP}$ ,  $f_i$ ,  $N_i$  shall be as listed in the test conditions column for  $I_{CCT}$  in table I, herein.
- 8/ This test may be performed either one input at a time (preferred method) or with all input pins simultaneously at  $V_{IN} = V_{CC} - 2.1 V$  (alternate method). Classes Q and V shall use the preferred method. When the test is performed using the alternate test method, the maximum limit is equal to the number of inputs at a high TTL input level times 2.0 mA and the preferred method and limits are guaranteed.
- 9/  $I_{CCT}$  is calculated as follows:  

$$I_{CCT} = I_{CC} = D_H N_T \Delta I_{CC} + I_{CCD}(f_{CP}/2 + f_i N_i)$$

Where:  
 $I_{CC}$  = Quiescent supply current (any  $I_{CCL}$  or  $I_{CCH}$ )  
 $D_H$  = Duty cycle for TTL inputs at 3.4 V  
 $N_T$  = Number of TTL inputs at 3.4 V  
 $\Delta I_{CC}$  = Quiescent supply current delta, TTL inputs at 3.4 V  
 $I_{CCD}$  = Dynamic power supply current caused by an input transition pair (HLH or LHL)  
 $f_{CP}$  = Clock frequency for registered devices ( $f_{CP} = 0$  for nonregistered devices)  
 $f_i$  = Input frequency  
 $N_i$  = Number of inputs at  $f_i$
- 10/ Tests shall be performed in sequence, attributes data only. Functional tests shall include the truth table and other logic patterns used for fault detection. The test vectors used to verify the truth table shall, at a minimum, test all functions of each input and output. All possible input to output logic patterns per function shall be guaranteed, if not tested, to the truth table in figure 2, herein. Functional tests shall be performed in sequence as approved by the qualifying activity on qualified devices.  $H \geq 1.5 V$ ,  $L < 1.5 V$ .
- 11/ AC limits at  $V_{CC} = 5.5 V$  are equal to the limits at  $V_{CC} = 4.5 V$  and guaranteed by testing at  $V_{CC} = 4.5 V$ . Minimum propagation delay time limits for  $V_{CC} = 4.5 V$  and  $5.5 V$  are guaranteed if not tested to the limits specified in table I, herein. For AC tests, all paths must be tested.

<b>STANDARD</b> <b>MICROCIRCUIT DRAWING</b> DEFENSE SUPPLY CENTER COLUMBUS COLUMBUS, OHIO 43218-3990	SIZE <b>A</b>		<b>5962-92233</b>
		REVISION LEVEL A	SHEET <b>8</b>



Device types	01, 02, 03, 04, 05, 06	
Case outlines	E and F	2
Terminal number	Terminal symbol	
1	A0	NC
2	A1	A0
3	A2	A1
4	$\overline{E1}$	A2
5	$\overline{E2}$	$\overline{E1}$
6	E3	NC
7	$\overline{O7}$	$\overline{E2}$
8	GND	$\overline{E3}$
9	$\overline{O6}$	$\overline{O7}$
10	$\overline{O5}$	GND
11	$\overline{O4}$	NC
12	$\overline{O3}$	$\overline{O6}$
13	$\overline{O2}$	$\overline{O5}$
14	$\overline{O1}$	$\overline{O4}$
15	$\overline{O0}$	$\overline{O3}$
16	V <sub>CC</sub>	NC
17	---	$\overline{O2}$
18	---	$\overline{O1}$
19	---	$\overline{O0}$
20	---	V <sub>CC</sub>

NC = No connection

Terminal description	
Terminal symbol	Description
A0, A1, A2	Address inputs
$\overline{E1}$ , $\overline{E2}$	Enable inputs (active low)
E3	Enable input (active high)
On (n = 0 to 7)	Outputs (active low)

FIGURE 1. Terminal connections.

<b>STANDARD MICROCIRCUIT DRAWING</b> DEFENSE SUPPLY CENTER COLUMBUS COLUMBUS, OHIO 43218-3990	SIZE <b>A</b>		<b>5962-92233</b>
		REVISION LEVEL A	SHEET <b>9</b>

Inputs						Outputs							
$\overline{E1}$	$\overline{E2}$	E3	A0	A1	A2	$\overline{O0}$	$\overline{O1}$	$\overline{O2}$	$\overline{O3}$	$\overline{O4}$	$\overline{O5}$	$\overline{O6}$	$\overline{O7}$
H	X	X	X	X	X	H	H	H	H	H	H	H	H
X	H	X	X	X	X	H	H	H	H	H	H	H	H
X	X	L	X	X	X	H	H	H	H	H	H	H	H
L	L	H	L	L	L	L	H	H	H	H	H	H	H
L	L	H	H	L	L	H	L	H	H	H	H	H	H
L	L	H	L	H	L	H	H	L	H	H	H	H	H
L	L	H	H	H	L	H	H	H	L	H	H	H	H
L	L	H	L	L	H	H	H	H	H	L	H	H	H
L	L	H	H	L	H	H	H	H	H	H	L	H	H
L	L	H	L	H	H	H	H	H	H	H	H	L	H
L	L	H	H	H	H	H	H	H	H	H	H	H	L

L = Low voltage level  
H = High voltage level  
X = Irrelevant

FIGURE 2. Truth table.

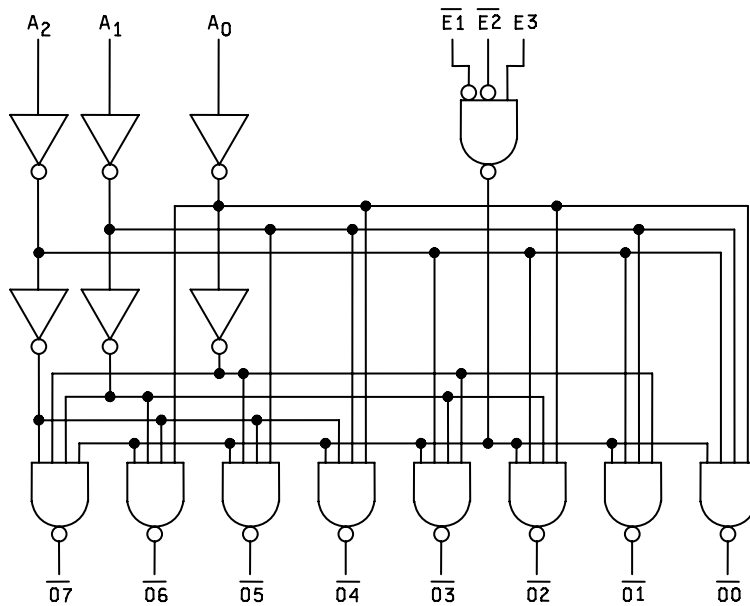

FIGURE 3. Logic diagram.

**STANDARD  
MICROCIRCUIT DRAWING**  
DEFENSE SUPPLY CENTER COLUMBUS  
COLUMBUS, OHIO 43218-3990

SIZE  
**A**

**5962-92233**

REVISION LEVEL  
**A**

SHEET  
**10**

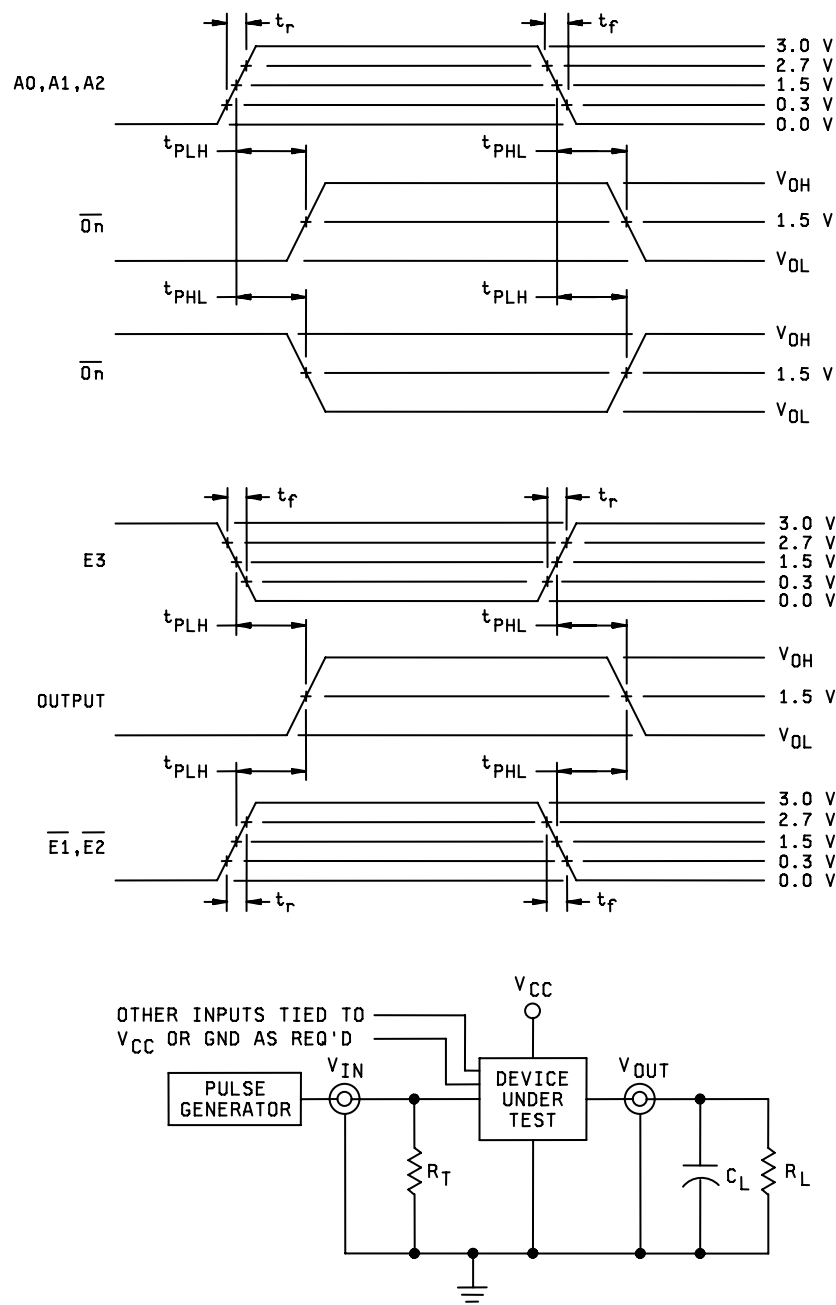

NOTES:

1.  $C_L = 50$  pF or equivalent (includes test jig and probe capacitance).
2.  $R_L = 500\Omega$  or equivalent.  $R_T = 50\Omega$  or equivalent.
3. Input signal from pulse generator:  $V_{IN} = 0.0$  V to 3.0 V;  $PRR \leq 10$  MHz; duty cycle = 50 percent;  $t_r \leq 2.5$  ns,  $t_f \leq 2.5$  ns;  $t_r$  and  $t_f$  shall be measured from 0.3 V to 2.7 V, and from 2.7 V to 0.3 V, respectively.
4. Timing parameters shall be tested at a minimum input frequency of 1 MHz.
5. The outputs are measured one at a time with one transition per measurement.

FIGURE 4. Switching waveforms and test circuit.

**STANDARD  
MICROCIRCUIT DRAWING**  
DEFENSE SUPPLY CENTER COLUMBUS  
COLUMBUS, OHIO 43218-3990

SIZE  
**A**

**5962-92233**

REVISION LEVEL  
**A**

SHEET  
**11**

4. VERIFICATION

4.1 Sampling and inspection. For device classes Q and V, sampling and inspection procedures shall be in accordance with MIL-PRF-38535 or as modified in the device manufacturer's Quality Management (QM) plan. The modification in the QM plan shall not affect the form, fit, or function as described herein. For device class M, sampling and inspection procedures shall be in accordance with MIL-PRF-38535, appendix A.

4.2 Screening. For device classes Q and V, screening shall be in accordance with MIL-PRF-38535, and shall be conducted on all devices prior to qualification and technology conformance inspection. For device class M, screening shall be in accordance with method 5004 of MIL-STD-883, and shall be conducted on all devices prior to quality conformance inspection.

4.2.1 Additional criteria for device class M.

- a. Burn-in test, method 1015 of MIL-STD-883.
  - (1) Test condition A, B, C, or D. The test circuit shall be maintained by the manufacturer under document revision level control and shall be made available to the preparing or acquiring activity upon request. The test circuit shall specify the inputs, outputs, biases, and power dissipation, as applicable, in accordance with the intent specified in method 1015 of MIL-STD-883.
  - (2)  $T_A = +125^{\circ}\text{C}$ , minimum.
- b. Interim and final electrical test parameters shall be as specified in table II herein.

4.2.2 Additional criteria for device classes Q and V.

- a. The burn-in test duration, test condition and test temperature, or approved alternatives shall be as specified in the device manufacturer's QM plan in accordance with MIL-PRF-38535. The burn-in test circuit shall be maintained under document revision level control of the device manufacturer's Technology Review Board (TRB) in accordance with MIL-PRF-38535 and shall be made available to the acquiring or preparing activity upon request. The test circuit shall specify the inputs, outputs, biases, and power dissipation, as applicable, in accordance with the intent specified in method 1015 of MIL-STD-883.
- b. Interim and final electrical test parameters shall be as specified in table II herein.
- c. Additional screening for device class V beyond the requirements of device class Q shall be as specified in MIL-PRF-38535, appendix B.

4.3 Qualification inspection for device classes Q and V. Qualification inspection for device classes Q and V shall be in accordance with MIL-PRF-38535. Inspections to be performed shall be those specified in MIL-PRF-38535 and herein for groups A, B, C, D, and E inspections (see 4.4.1 through 4.4.4).

4.4 Conformance inspection. Technology conformance inspection for classes Q and V shall be in accordance with MIL-PRF-38535 including groups A, B, C, D, and E inspections and as specified herein. Quality conformance inspection for device class M shall be in accordance with MIL-PRF-38535, appendix A and as specified herein. Inspections to be performed for device class M shall be those specified in method 5005 of MIL-STD-883 and herein for groups A, B, C, D, and E inspections (see 4.4.1 through 4.4.4).

4.4.1 Group A inspection.

- a. Tests shall be as specified in table II herein.
- b.  $C_{IN}$  and  $C_{OUT}$  shall be measured only for initial qualification and after process or design changes which may affect capacitance.  $C_{IN}$  and  $C_{OUT}$  shall be measured between the designated terminal and GND at a frequency of 1 MHz. For  $C_{IN}$  and  $C_{OUT}$ , test all applicable pins on five devices with zero failures.
- c. For device class M, subgroups 7 and 8 tests shall be sufficient to verify the truth table in figure 2 herein. The test vectors used to verify the truth table shall, at a minimum, test all functions of each input and output. All possible input to output logic patterns per function shall be guaranteed, if not tested, to the truth table in figure 2, herein. For device classes Q and V, subgroups 7 and 8 shall include verifying the functionality of the device.

<b>STANDARD MICROCIRCUIT DRAWING</b> DEFENSE SUPPLY CENTER COLUMBUS COLUMBUS, OHIO 43218-3990	SIZE <b>A</b>		<b>5962-92233</b>
		REVISION LEVEL A	SHEET <b>12</b>

4.4.2 Group C inspection. The group C inspection end-point electrical parameters shall be as specified in table II herein.

4.4.2.1 Additional criteria for device class M. Steady-state life test conditions, method 1005 of MIL-STD-883:

- a. Test condition A, B, C, or D. The test circuit shall be maintained by the manufacturer under document revision level control and shall be made available to the preparing or acquiring activity upon request. The test circuit shall specify the inputs, outputs, biases, and power dissipation, as applicable, in accordance with the intent specified in method 1005 of MIL-STD-883.
- b.  $T_A = +125^\circ\text{C}$ , minimum.
- c. Test duration: 1,000 hours, except as permitted by method 1005 of MIL-STD-883.

4.4.2.2 Additional criteria for device classes Q and V. The steady-state life test duration, test condition and test temperature, or approved alternatives shall be as specified in the device manufacturer's QM plan in accordance with MIL-PRF-38535. The test circuit shall be maintained under document revision level control by the device manufacturer's TRB in accordance with MIL-PRF-38535 and shall be made available to the acquiring or preparing activity upon request. The test circuit shall specify the inputs, outputs, biases, and power dissipation, as applicable, in accordance with the intent specified in method 1005 of MIL-STD-883.

4.4.3 Group D inspection. The group D inspection end-point electrical parameters shall be as specified in table II herein.

4.4.4 Group E inspection. Group E inspection is required only for parts intended to be marked as radiation hardness assured (see 3.5 herein).

- a. End-point electrical parameters shall be as specified in table II herein.
- b. For device classes Q and V, the devices or test vehicle shall be subjected to radiation hardness assured tests as specified in MIL-PRF-38535 for the RHA level being tested. For device class M, the devices shall be subjected to radiation hardness assured tests as specified in MIL-PRF-38535, appendix A for the RHA level being tested. All device classes must meet the postirradiation end-point electrical parameter limits as defined in table I at  $T_A = +25^\circ\text{C} \pm 5^\circ\text{C}$ , after exposure, to the subgroups specified in table II herein.

TABLE II. Electrical test requirements.

Test requirements	Subgroups (in accordance with MIL-STD-883, method 5005, table I)	Subgroups (in accordance with MIL-PRF-38535, table III)	
	Device class M	Device class Q	Device class V
Interim electrical parameters (see 4.2)	---	1	1
Final electrical parameters (see 4.2)	<u>1/</u> 1, 2, 3, 4, 5, 6, 7, 8, 9, 10, 11	<u>1/</u> 1, 2, 3, 4, 5, 6, 7, 8, 9, 10, 11	<u>2/</u> 1, 2, 3, 4, 5, 6, 7, 8, 9, 10, 11
Group A test requirements (see 4.4)	1, 2, 3, 4, 5, 6, 7, 8, 9, 10, 11	1, 2, 3, 4, 5, 6, 7, 8, 9, 10, 11	1, 2, 3, 4, 5, 6, 7, 8, 9, 10, 11
Group C end-point electrical parameters (see 4.4)	1, 2, 3, 4, 5, 6	1, 2, 3, 4, 5, 6	
Group D end-point electrical parameters (see 4.4)	1, 2, 3	1, 2, 3	1, 2, 3
Group E end-point electrical parameters (see 4.4)	1, 4, 7, 9	1, 4, 7, 9	1, 4, 7, 9

1/ PDA applies to subgroup 1.  
2/ PDA applies to subgroups 1 and 7.

<b>STANDARD MICROCIRCUIT DRAWING</b> DEFENSE SUPPLY CENTER COLUMBUS COLUMBUS, OHIO 43218-3990	SIZE <b>A</b>		<b>5962-92233</b>
		REVISION LEVEL A	SHEET <b>13</b>

4.5 Methods of inspection. Methods of inspection shall be specified as follows:

4.5.1 Voltage and current. Unless otherwise specified, all voltages given are referenced to the microcircuit GND terminal. Currents given are conventional current and positive when flowing into the referenced terminal.

5. PACKAGING

5.1 Packaging requirements. The requirements for packaging shall be in accordance with MIL-PRF-38535 for device classes Q and V or MIL-PRF-38535, appendix A for device class M.

6. NOTES

6.1 Intended use. Microcircuits conforming to this drawing are intended for use for Government microcircuit applications (original equipment), design applications, and logistics purposes.

6.1.1 Replaceability. Microcircuits covered by this drawing will replace the same generic device covered by a contractor-prepared specification or drawing.

6.1.2 Substitutability. Device class Q devices will replace device class M devices.

6.2 Configuration control of SMD's. All proposed changes to existing SMD's will be coordinated with the users of record for the individual documents. This coordination will be accomplished using DD Form 1692, Engineering Change Proposal.

6.3 Record of users. Military and industrial users should inform Defense Supply Center Columbus (DSCC) when a system application requires configuration control and which SMD's are applicable to that system. DSCC will maintain a record of users and this list will be used for coordination and distribution of changes to the drawings. Users of drawings covering microelectronic devices (FSC 5962) should contact DSCC-VA, telephone (614) 692-0544.

6.4 Comments. Comments on this drawing should be directed to DSCC-VA, Columbus, Ohio 43218-3990, or telephone (614) 692-0547.

6.5 Abbreviations, symbols, and definitions. The abbreviations, symbols, and definitions used herein are defined in MIL-PRF-38535 and MIL-HDBK-1331.

6.6 Sources of supply.

6.6.1 Sources of supply for device classes Q and V. Sources of supply for device classes Q and V are listed in QML-38535. The vendors listed in QML-38535 have submitted a certificate of compliance (see 3.6 herein) to DSCC-VA and have agreed to this drawing.

6.6.2 Approved sources of supply for device class M. Approved sources of supply for class M are listed in MIL-HDBK-103. The vendors listed in MIL-HDBK-103 have agreed to this drawing and a certificate of compliance (see 3.6 herein) has been submitted to and accepted by DSCC-VA.

<b>STANDARD MICROCIRCUIT DRAWING</b> DEFENSE SUPPLY CENTER COLUMBUS COLUMBUS, OHIO 43218-3990	SIZE <b>A</b>		<b>5962-92233</b>
		REVISION LEVEL A	SHEET <b>14</b>

## STANDARD MICROCIRCUIT DRAWING BULLETIN

DATE: 06-12-06

Approved sources of supply for SMD 5962-92233 are listed below for immediate acquisition information only and shall be added to MIL-HDBK-103 and QML-38535 during the next revision. MIL-HDBK-103 and QML-38535 will be revised to include the addition or deletion of sources. The vendors listed below have agreed to this drawing and a certificate of compliance has been submitted to and accepted by DSCC-VA. This information bulletin is superseded by the next dated revision of MIL-HDBK-103 and QML-38535. DSCC maintains an online database of all current sources of supply at <http://www.dscclia.mil/Programs/Smcr/>.

Standard microcircuit drawing PIN <u>1/</u>	Vendor CAGE number	Vendor similar PIN <u>2/</u>
5962-9223301MEA	<u>3/</u>	54FCT138T
5962-9223301M2A	<u>3/</u>	54FCT138T
5962-9223302MEA	01295 0C7V7	CY54FCT138TDMB IDT54FCT138TDB
5962-9223302MFA	0C7V7	IDT54FCT138TEB
5962-9223302M2A	01295 0C7V7	CY54FCT138TLMB IDT54FCT138TLB
5962-9223303MEA	<u>3/</u>	54FCT138AT
5962-9223303M2A	<u>3/</u>	54FCT138AT
5962-9223304M2A	0C7V7	IDT54FCT138ATLB
5962-9223304MEA	0C7V7	IDT54FCT138ATDB
5962-9223304MFA	0C7V7	IDT54FCT138ATEB
5962-9223305M2A	<u>3/</u>	54FCT138CT
5962-9223305MEA	<u>3/</u>	54FCT138CT
5962-9223306M2A	01295 0C7V7	CY54FCT138CTLMB IDT54FCT138CTLB
5962-9223306MEA	01295 0C7V7	CY54FCT138CTDMB IDT54FCT138CTDB
5962-9223306MFA	0C7V7	IDT54FCT138CTEB

- 1/ The lead finish shown for each PIN representing a hermetic package is the most readily available from the manufacturer listed for that part. If the desired lead finish is not listed, contact the vendor to determine its availability.
- 2/ Caution. Do not use this number for item acquisition. Items acquired to this number may not satisfy the performance requirements of this drawing.
- 3/ Not available from an approved source of supply.

STANDARD MICROCIRCUIT DRAWING BULLETIN – Continued.

<u>Vendor CAGE number</u>	<u>Vendor name and address</u>
01295	Texas Instruments Inc. Semiconductor Group 8505 Forest Ln. P.O. Box 660199 Dallas, TX 75243 Point of contact: U.S. Highway 75 South P.O. Box 84, M/S 853 Sherman, TX 75090-9493
0C7V7	QP Semiconductor 2945 Oakmead Village Court Santa Clara, CA 95051

The information contained herein is disseminated for convenience only and the Government assumes no liability whatsoever for any inaccuracies in the information bulletin.