

REVISIONS

LTR	DESCRIPTION	DATE (YR-MO-DA)	APPROVED
A	Boilerplate update and part of five year review. tcr	06-08-09	Raymond Monnin

REV																				
SHEET																				
REV	A	A																		
SHEET	15	16																		

REV STATUS OF SHEETS	REV	A	A	A	A	A	A	A	A	A	A	A	A	A	A	A	A	A	A
	SHEET	1	2	3	4	5	6	7	8	9	10	11	12	13	14				

PMIC N/A	PREPARED BY Gary L. Gross	<p align="center">DEFENSE SUPPLY CENTER COLUMBUS COLUMBUS, OHIO 43218-3990 http://www.dsc.dla.mil</p> <p>MICROCIRCUIT, MEMORY, DIGITAL, CMOS, REGISTERED 32K X 8 - BIT PROM, MONOLITHIC SILICON</p>																	
STANDARD MICROCIRCUIT DRAWING THIS DRAWING IS AVAILABLE FOR USE BY ALL DEPARTMENTS AND AGENCIES OF THE DEPARTMENT OF DEFENSE AMSC N/A	CHECKED BY Jeffery D. Bowling																		
	APPROVED BY Michael A. Frye																		
	DRAWING APPROVAL DATE 93-03-19																		
	REVISION LEVEL A	SIZE A	CAGE CODE 67268	5962-92155															
		SHEET		1 OF 16															

1. SCOPE

1.1 Scope. This drawing documents two product assurance class levels consisting of high reliability (device classes Q and M) and space application (device class V). A choice of case outlines and lead finishes are available and are reflected in the Part or Identifying Number (PIN). When available, a choice of Radiation Hardness Assurance (RHA) levels are reflected in the PIN.

1.2 PIN. The PIN is as shown in the following example:

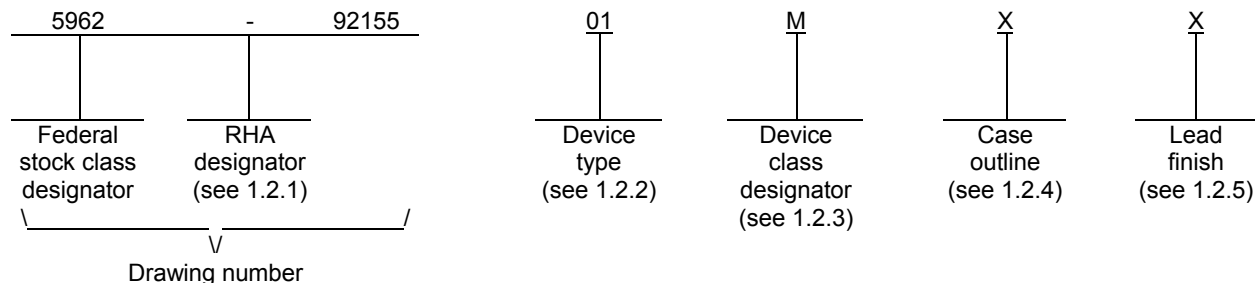

1.2.1 RHA designator. Device classes Q and V RHA marked devices meet the MIL-PRF-38535 specified RHA levels and are marked with the appropriate RHA designator. Device class M RHA marked devices meet the MIL-PRF-38535, appendix A specified RHA levels and are marked with the appropriate RHA designator. A dash (-) indicates a non-RHA device.

1.2.2 Device type(s). The device type(s) identify the circuit function as follows:

Device type	Generic number ^{1/}	Circuit function	Access time
01	CY7C277-50	32K X 8-bit registered PROM	50 ns
02	CY7C277-40	32K X 8-bit registered PROM	40 ns

1.2.3 Device class designator. The device class designator is a single letter identifying the product assurance level as follows:

Device class	Device requirements documentation
M	Vendor self-certification to the requirements for MIL-STD-883 compliant, non-JAN class level B microcircuits in accordance with MIL-PRF-38535, appendix A
Q or V	Certification and qualification to MIL-PRF-38535

1.2.4 Case outline(s). The case outline(s) are as designated in MIL-STD-1835 and as follows:

Outline letter	Descriptive designator	Terminals	Package style
X	CDIP3-T28 or GDIP4-T28	28	Dual-in-line package
Y	CQCC1-N32	32	Rectangular leadless chip carrier package
Z	GDFP2-F28	28	Flat pack

1.2.5 Lead finish. The lead finish is as specified in MIL-PRF-38535 for device classes Q and V or MIL-PRF-38535, appendix A for device class M.

^{1/} Generic numbers are also listed on the Standard Microcircuit Drawing Source Approval Bulletin at the end of this document and will also be listed in MIL-HDBK-103 and QML-38535.

STANDARD MICROCIRCUIT DRAWING DEFENSE SUPPLY CENTER COLUMBUS COLUMBUS, OHIO 43218-3990	SIZE A		5962-92155
		REVISION LEVEL A	SHEET 2

1.3 Absolute maximum ratings. 1/

Supply voltage range to ground potential (V_{CC})	-0.5 V dc to +7.0 V dc
DC voltage applied to the outputs in the high Z state	-0.5 V dc to +7.0 V dc
DC input voltage	-3.0 V dc to +7.0 V dc
DC program voltage	13.0 V dc
Maximum power dissipation	1.0 W 2/
Lead temperature (soldering, 10 seconds)	+260°C
Thermal resistance, junction-to-case (θ_{JC})	See MIL-STD-1835
Junction temperature (T_J)	+175°C
Storage temperature range (T_{STG})	-65°C to +150°C
Temperature under bias	-55°C to +125°C
Data retention	10 years, minimum

1.4 Recommended operating conditions.

Supply voltage range (V_{CC})	+4.5 V dc minimum to +5.5 V dc maximum
Ground voltage (GND)	0 V dc
Input high voltage (V_{IH})	2.0 V dc minimum
Input low voltage (V_{IL})	0.8 V dc maximum
Case operating temperature range (T_C)	-55°C to +125°C

2. APPLICABLE DOCUMENTS

2.1 Government specification, standards, and handbooks. The following specification, standards, and handbooks form a part of this drawing to the extent specified herein. Unless otherwise specified, the issues of these documents are those cited in the solicitation or contract.

DEPARTMENT OF DEFENSE SPECIFICATION

MIL-PRF-38535 - Integrated Circuits, Manufacturing, General Specification for.

DEPARTMENT OF DEFENSE STANDARDS

MIL-STD-883 - Test Method Standard Microcircuits.
 MIL-STD-1835 - Interface Standard Electronic Component Case Outlines.

DEPARTMENT OF DEFENSE HANDBOOKS

MIL-HDBK-103 - List of Standard Microcircuit Drawings.
 MIL-HDBK-780 - Standard Microcircuit Drawings.

(Copies of these documents are available online at <http://assist.daps.dla.mil/quicksearch/> or <http://assist.daps.dla.mil> or from the Standardization Document Order Desk, 700 Robbins Avenue, Building 4D, Philadelphia, PA 19111-5094.)

2.2 Non-Government publications. The following documents form a part of this document to the extent specified herein. Unless otherwise specified, the issues of the documents are the issues of the documents cited in the solicitation.

AMERICAN SOCIETY FOR TESTING AND MATERIALS (ASTM)

ASTM Standard F1192-00 - Standard Guide for the Measurement of Single Event Phenomena (SEP) induced by Heavy Ion Irradiation of Semiconductor Devices.

(Applications for copies of ASTM publications should be addressed to: ASTM International, PO Box C700, 100 Barr Harbor Drive, West Conshohocken, PA 19428-2959; <http://www.astm.org>.)

1/ Stresses above the absolute maximum rating may cause permanent damage to the device. Extended operation at the maximum levels may degrade performance and affect reliability.

2/ Must withstand the added P_D due to short circuit test e.g.; I_{OS} .

STANDARD MICROCIRCUIT DRAWING DEFENSE SUPPLY CENTER COLUMBUS COLUMBUS, OHIO 43218-3990	SIZE A		5962-92155
		REVISION LEVEL A	SHEET 3

ELECTRONICS INDUSTRIES ALLIANCE (EIA)

JEDEC Standard EIA/JESD 78 - IC Latch-Up Test.

(Applications for copies should be addressed to the Electronics Industries Alliance, 2500 Wilson Boulevard, Arlington, VA 22201; <http://www.jedec.org>.)

(Non-Government standards and other publications are normally available from the organizations that prepare or distribute the documents. These documents also may be available in or through libraries or other informational services.)

2.3 Order of precedence. In the event of a conflict between the text of this drawing and the references cited herein, the text of this drawing takes precedence. Nothing in this document, however, supersedes applicable laws and regulations unless a specific exemption has been obtained.

3. REQUIREMENTS

3.1 Item requirements. The individual item requirements for device classes Q and V shall be in accordance with MIL-PRF-38535 and as specified herein or as modified in the device manufacturer's Quality Management (QM) plan. The modification in the QM plan shall not affect the form, fit, or function as described herein. The individual item requirements for device class M shall be in accordance with MIL-PRF-38535, appendix A for non-JAN class level B devices and as specified herein.

3.2 Design, construction, and physical dimensions. The design, construction, and physical dimensions shall be as specified in MIL-PRF-38535 and herein for device classes Q and V or MIL-PRF-38535, appendix A and herein for device class M.

3.2.1 Case outlines. The case outline(s) shall be in accordance with 1.2.4 herein.

3.2.2 Terminal connections. The terminal connections shall be as specified on figure 1.

3.2.3 Truth table. The truth table shall be as specified on figure 2.

3.2.3.1 Unprogrammed devices. The truth table for unprogrammed devices for contracts involving no altered item drawing shall be as specified on figure 2 herein. When required in screening (see 4.2 herein) or qualification conformance inspection groups A, B, C, or D (see 4.4 herein), the devices shall be programmed by the manufacturer prior to test. A minimum of 50 percent of the total number of cells shall be programmed or at least 25 percent of the total number of cells to any altered item drawing.

3.2.3.2 Programmed devices. The truth table for programmed devices shall be as specified by an attached altered item drawing.

STANDARD MICROCIRCUIT DRAWING DEFENSE SUPPLY CENTER COLUMBUS COLUMBUS, OHIO 43218-3990	SIZE A		5962-92155
		REVISION LEVEL A	SHEET 4

TABLE I. Electrical performance characteristics.

Test	Symbol	Conditions -55°C ≤ T _C ≤ +125°C 4.5 V ≤ V _{CC} ≤ 5.5 V unless otherwise specified	Group A subgroups	Device type	Limits		Unit
					Min	Max	
Output high voltage	V _{OH}	V _{CC} = 4.5 V, I _{OH} = -2 mA, V _{IH} = 2.0 V, V _{IL} = 0.8 V	1,2,3	All	2.4		V
Output low voltage	V _{OL}	V _{CC} = 4.5 V, I _{OL} = 8 mA, V _{IH} = 2.0 V, V _{IL} = 0.8 V	1,2,3	All		0.4	V
Input high voltage <u>1/</u>	V _{IH}		1,2,3	All	2.0		V
Input low voltage <u>1/</u>	V _{IL}		1,2,3	All		0.8	V
Input leakage current	I _{IX}	V _{CC} = 5.5 V V _{IN} = V _{CC} to GND	1,2,3	All	-10	10	μA
Output leakage current	I _{OZ}	V _{CC} = 5.5 V V _{OUT} = V _{CC} to GND <u>2/</u>	1,2,3	All	-40	40	μA
Output short circuit current <u>3/ 4/</u>	I _{OS}	V _{CC} = 5.5 V, V _{OUT} = GND	1,2,3	All	-20	-90	mA
Power supply current	I _{CC}	V _{CC} = 5.5 V, I _{OUT} = 0 mA, V _{IH} = 2.0 V, f = f _{MAX} <u>5/</u>	1,2,3	All		130	mA
Input capacitance <u>4/</u>	C _{IN}	V _{CC} = 5.0 V, V _{IN} = 2.0 V, T _A = +25°C, f = 1 MHz (see 4.4.1c)	4	All		10	pF
Output capacitance <u>4/</u>	C _{OUT}	V _{CC} = 5.0 V, V _{IN} = 2.0 V, T _A = +25°C, f = 1 MHz (see 4.4.1c)	4	All		10	pF
Functional tests		See 4.4.1d	7, 8A, 8B	All			
Address setup to ALE inactive	t _{AL}	See figures 3 and 4 and <u>6/</u>	9, 10, 11	All	10		ns
Address hold from ALE inactive	t _{LA}			01	15		ns
				02	10		

See footnotes at end of table.

STANDARD MICROCIRCUIT DRAWING DEFENSE SUPPLY CENTER COLUMBUS COLUMBUS, OHIO 43218-3990	SIZE A		5962-92155
		REVISION LEVEL A	SHEET 5

TABLE I. Electrical performance characteristics - Continued.

Test	Symbol	Conditions -55°C ≤ T _C ≤ +125°C 4.5 V ≤ V _{CC} ≤ 5.5 V unless otherwise specified	Group A subgroups	Device type	Limits		Unit
					Min	Max	
Address pulse width	t _{LL}	See figures 3 and 4 and 6/	9, 10, 11	01	15		ns
				02	10		
Address setup to clock high	t _{SA}			01	50		
				02	40		
Address hold time from clock high	t _{HA}			All	0		
\bar{E}_S setup to clock high 3/	t _{SES}			All	15		
\bar{E}_S hold from clock high 3/	t _{HES}			All	10		
Output valid from clock high 3/	t _{CO}			01		25	
				02		20	
Clock pulse width	t _{PWC}			All	20		
Output low Z from clock high 4/ 7/	t _{LZC}			01		30	
				02		20	
Output high Z from clock high 4/ 7/ 9/	t _{HZC}			01		30	
				02		20	
Output low Z from \bar{E} low 4/ 8/	t _{LZE}			01		30	
				02		20	
Output high Z from \bar{E} high 4/ 8/ 9/	t _{HZE}			01		30	
				02		20	

- 1/ These are absolute values with respect to device ground and all overshoots and undershoots due to system or tester noise are included.
- 2/ For devices using the synchronous enable, the device must be clocked after applying these voltages to perform this measurement.
- 3/ For test purposes, not more than one output at a time should be shorted. Short circuit test duration should not exceed 1 second. V_{OUT} = 0.5 V has been chosen to avoid test problems caused by tester ground degradation.
- 4/ Tested initially and after any design or process changes that affect that parameter, and therefore shall be guaranteed to the limits specified in table I.
- 5/ At f = f_{max}, address inputs are cycling at the maximum frequency of 1/t_{SA}.
- 6/ AC tests are performed with input rise and fall times of 5 ns or less, timing reference levels of 1.5 V, input pulse levels of 0 to 3.0 V, and the output load on figure 3.
- 7/ Applies only when the synchronous \bar{E}_S function is used.
- 8/ Applies only when the synchronous \bar{E} function is used.
- 9/ Transition is measured at steady-state high level -500 mV or steady-state low level +500 mV on the output from the 1.5 V level on the input, C_L = 5 pF (including scope and jig). See figure 3.

STANDARD MICROCIRCUIT DRAWING DEFENSE SUPPLY CENTER COLUMBUS COLUMBUS, OHIO 43218-3990	SIZE A		5962-92155
		REVISION LEVEL A	SHEET 6

3.3 Electrical performance characteristics and postirradiation parameter limits. Unless otherwise specified herein, the electrical performance characteristics and postirradiation parameter limits are as specified in table I and shall apply over the full case operating temperature range.

3.4 Electrical test requirements. The electrical test requirements shall be the subgroups specified in table IIA. The electrical tests for each subgroup are defined in table I.

3.5 Marking. The part shall be marked with the PIN listed in 1.2 herein. In addition, the manufacturer's PIN may also be marked. For packages where marking of the entire SMD PIN number is not feasible due to space limitations, the manufacturer has the option of not marking the "5962-" on the device. For RHA product using this option, the RHA designator shall still be marked. Marking for device classes Q and V shall be in accordance with MIL-PRF-38535. Marking for device class M shall be in accordance with MIL-PRF-38535, appendix A.

3.5.1 Certification/compliance mark. The certification mark for device classes Q and V shall be a "QML" or "Q" as required in MIL-PRF-38535. The compliance mark for device class M shall be a "C" as required in MIL-PRF-38535, appendix A.

3.6 Certificate of compliance. For device classes Q and V, a certificate of compliance shall be required from a QML-38535 listed manufacturer in order to supply to the requirements of this drawing (see 6.6.2 herein). For device class M, a certificate of compliance shall be required from a manufacturer in order to be listed as an approved source of supply in MIL-HDBK-103 (see 6.6.2 herein). The certificate of compliance submitted to DSCC-VA prior to listing as an approved source of supply for this drawing shall affirm that the manufacturer's product meets, for device classes Q and V, the requirements of MIL-PRF-38535 and herein or for device class M, the requirements of MIL-PRF-38535, appendix A and herein.

3.7 Certificate of conformance. A certificate of conformance as required for device classes Q and V in MIL-PRF-38535 or for device class M in MIL-PRF-38535, appendix A shall be provided with each lot of microcircuits delivered to this drawing.

3.8 Notification of change for device class M. For device class M, notification to DSCC-VA of change of product (see 6.2 herein) involving devices acquired to this drawing is required for any change that affects this drawing.

3.9 Verification and review for device class M. For device class M, DSCC, DSCC's agent, and the acquiring activity retain the option to review the manufacturer's facility and applicable required documentation. Offshore documentation shall be made available onshore at the option of the reviewer.

3.10 Microcircuit group assignment for device class M. Device class M devices covered by this drawing shall be in microcircuit group number 42 (see MIL-PRF-38535, appendix A).

3.10.1 Processing options. Since the device is capable of being programmed by either the manufacturer or the user to result in a wide variety of configurations, two processing options are provided for selection in the contract using an altered item drawing.

3.10.2 Unprogrammed device delivered to the user. All testing shall be verified through group A testing as defined in 3.2.3.1 and table IIA. It is recommended that users perform subgroups 7 and 9 after programming to verify the specific program configuration.

3.10.3 Manufacturer-programmed device delivered to the user. All testing requirements and quality assurance provisions herein, including the requirements of the altered item drawing, shall be satisfied by the manufacturer prior to delivery.

3.11 Serialization for device class V. Class V shall be serialized in accordance with MIL-PRF-38535.

4. VERIFICATION

4.1 Sampling and inspection. For device classes Q and V, sampling and inspection procedures shall be in accordance with MIL-PRF-38535 or as modified in the device manufacturer's Quality Management (QM) plan. The modification in the QM plan shall not affect the form, fit, or function as described herein. For device class M, sampling and inspection procedures shall be in accordance with MIL-PRF-38535, appendix A.

STANDARD MICROCIRCUIT DRAWING DEFENSE SUPPLY CENTER COLUMBUS COLUMBUS, OHIO 43218-3990	SIZE A		5962-92155
		REVISION LEVEL A	SHEET 7

Device types	All	
	X, Z	Y
Case outlines	Terminal symbol	
Terminal number	Terminal symbol	
1	A ₉	nc
2	A ₈	A ₉
3	A ₇	A ₈
4	A ₆	A ₇
5	A ₅	A ₆
6	A ₄	A ₅
7	A ₃	A ₄
8	A ₂	A ₃
9	A ₁	A ₂
10	A ₀	A ₁
11	O ₀	A ₀
12	O ₁	NC
13	O ₂	O ₀
14	GND	O ₁
15	O ₃	O ₂
16	O ₄	GND
17	O ₅	NC
18	O ₆	O ₃
19	O ₇	O ₄
20	\bar{E}/\bar{E}_S	O ₅
21	CP	O ₆
22	ALE	O ₇
23	A ₁₄	\bar{E}/\bar{E}_S
24	A ₁₃	CP
25	A ₁₂	ALE
26	A ₁₁	NC
27	A ₁₀	A ₁₄
28	V _{CC}	A ₁₃
29	----	A ₁₂
30	----	A ₁₁
31	----	A ₁₀
32	----	V _{CC}

FIGURE 1. Terminal connections.

STANDARD MICROCIRCUIT DRAWING DEFENSE SUPPLY CENTER COLUMBUS COLUMBUS, OHIO 43218-3990	SIZE A		5962-92155
		REVISION LEVEL A	SHEET 8

Read Modes

Mode	$A_{14} - A_0$	\bar{E}/\bar{E}_S	CP	ALE	OUTPUTS
Read	$A_{14} - A_0$	V_{IL}	V_{IH}	V_{IL}	$O_7 - O_0$
Output Disable	$A_{14} - A_0$	V_{IH}	X	X	HIGH Z

NOTE:

1. X can be V_{IL} or V_{IH}

FIGURE 2. Truth table.

**STANDARD
MICROCIRCUIT DRAWING**
DEFENSE SUPPLY CENTER COLUMBUS
COLUMBUS, OHIO 43218-3990

SIZE
A

REVISION LEVEL
A

5962-92155

SHEET
9

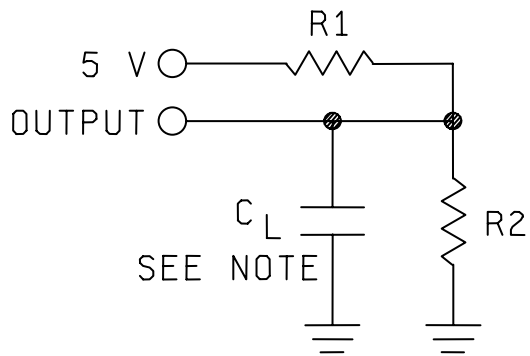

CIRCUIT A
OUTPUT LOAD

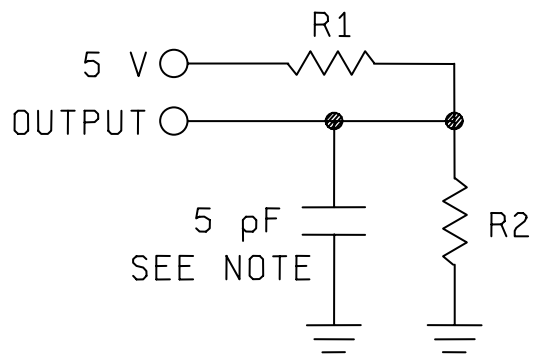

CIRCUIT B
OUTPUT LOAD FOR t_{HZC} AND t_{HZE}

NOTE: Including scope and jig (minimum values).

LOAD	Circuit	
	A	B
R1	658	658
R2	403	403
CL	30	5

AC test conditions

Input pulse levels	GND to 3.0 V
Input rise and fall times	≤ 5 ns
Input timing reference levels	1.5 V
Output reference levels	1.5 V

FIGURE 3. Output load circuit and test conditions.

**STANDARD
MICROCIRCUIT DRAWING**
DEFENSE SUPPLY CENTER COLUMBUS
COLUMBUS, OHIO 43218-3990

SIZE
A

REVISION LEVEL
A

5962-92155

SHEET
10

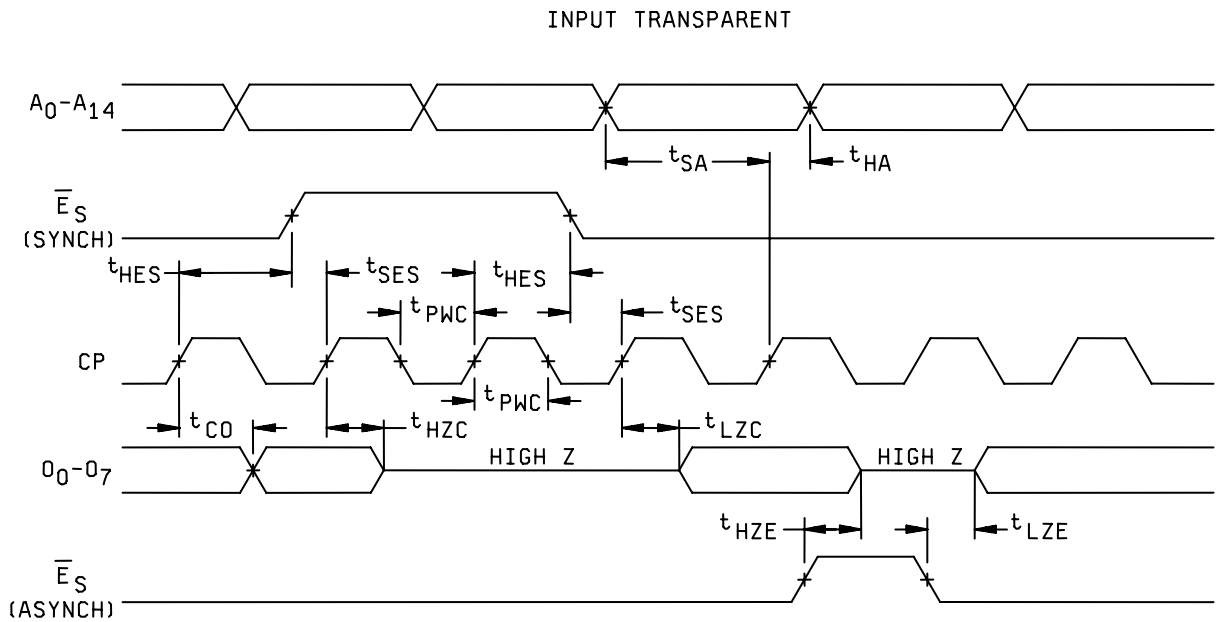
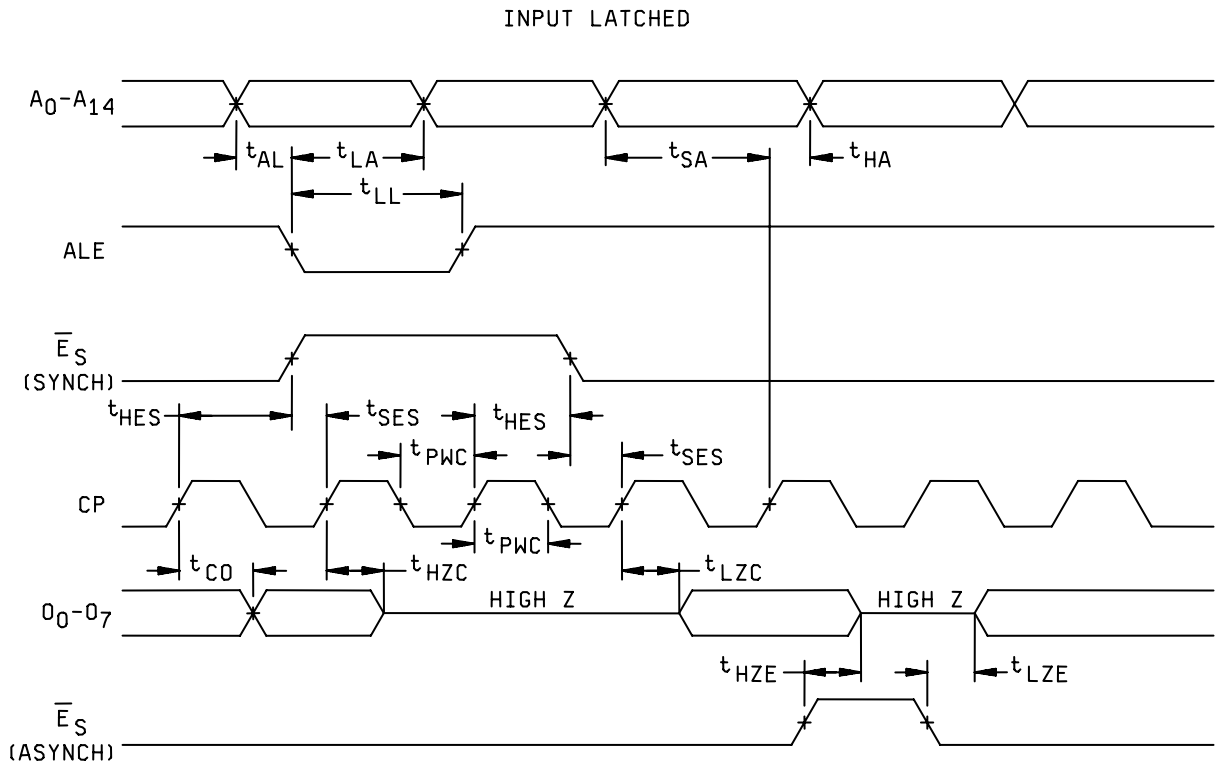

FIGURE 4. Switching waveforms.

**STANDARD
MICROCIRCUIT DRAWING**
DEFENSE SUPPLY CENTER COLUMBUS
COLUMBUS, OHIO 43218-3990

SIZE
A

5962-92155

REVISION LEVEL
A

SHEET
11

4.2 Screening. For device classes Q and V, screening shall be in accordance with MIL-PRF-38535, and shall be conducted on all devices prior to qualification and technology conformance inspection. For device class M, screening shall be in accordance with method 5004 of MIL-STD-883, and shall be conducted on all devices prior to quality conformance inspection.

4.2.1 Additional criteria for device class M.

- a. Delete the sequence specified as initial (preburn-in) electrical parameters through interim (postburn-in) electrical parameters of method 5004 and substitute lines 1 through 6 of table IIA herein.
- b. The test circuit shall be maintained by the manufacturer under document revision level control and shall be made available to the preparing or acquiring activity upon request. The test circuit shall specify the inputs, outputs, biases, and power dissipation, as applicable, in accordance with the intent specified in method 1015.
 - (1) Dynamic burn-in (method 1015 of MIL-STD-883, test condition D; for circuit, see 4.2.1b herein).
- c. Interim and final electrical parameters shall be as specified in table IIA herein.
- d. A data retention stress test shall be included as part of the screening procedure and shall consist of the following: (Steps 1 through 4 are performed at the wafer level.)
 - (1) Program 100 percent of the total number of cells, excluding the security bit.
 - (2) Bake, unbiased, for 72 hours at +140°C or for 48 hours at +150°C or for 8 hours at +200°C, or 2 hours at +300°C for unassembled devices only.
 - (3) Perform margin test using $V_m = +5.7 \text{ V}$ at +25°C using loose timing (i.e., $t_{SA} \geq 1 \mu\text{s}$).
 - (4) Erase.

4.2.2 Additional criteria for device classes Q and V.

- a. The burn-in test duration, test condition and test temperature, or approved alternatives shall be as specified in the device manufacturer's QM plan in accordance with MIL-PRF-38535. The burn-in test circuit shall be maintained under document revision level control of the device manufacturer's Technology Review Board (TRB) in accordance with MIL-PRF-38535 and shall be made available to the acquiring or preparing activity upon request. The test circuit shall specify the inputs, outputs, biases, and power dissipation, as applicable, in accordance with the intent specified in method 1015 of MIL-STD-883.
- b. Interim and final electrical test parameters shall be as specified in table IIA herein.
- c. Additional screening for device class V beyond the requirements of device class Q shall be as specified in MIL-PRF-38535, appendix B.

4.3 Qualification inspection for device classes Q and V. Qualification inspection for device classes Q and V shall be in accordance with MIL-PRF-38535. Inspections to be performed shall be those specified in MIL-PRF-38535 and herein for groups A, B, C, D, and E inspections (see 4.4.1 through 4.4.4).

4.4 Conformance inspection. Technology conformance inspection for classes Q and V shall be in accordance with MIL-PRF-38535 including groups A, B, C, D, and E inspections and as specified herein except where option 2 of MIL-PRF-38535 permits in-line control testing. Quality conformance inspection for device class M shall be in accordance with MIL-PRF-38535, appendix A and as specified herein. Inspections to be performed for device class M shall be those specified in method 5005 of MIL-STD-883 and herein for groups A, B, C, D, and E inspections (see 4.4.1 through 4.4.4).

STANDARD MICROCIRCUIT DRAWING DEFENSE SUPPLY CENTER COLUMBUS COLUMBUS, OHIO 43218-3990	SIZE A		5962-92155
		REVISION LEVEL A	SHEET 12

4.4.1 Group A inspection.

- a. Tests shall be as specified in table IIA herein.
- b. Subgroups 5 and 6 in table I, method 5005 of MIL-STD-883 shall be omitted.
- c. Subgroup 4 (C_{IN} and C_{OUT} measurements) shall be measured only for initial qualification and after any process or design changes which may affect input or output capacitance. Capacitance shall be measured between the designated terminal and GND at a frequency of 1 MHz. Sample size is 15 devices with no failures, and all input and output terminals tested.
- d. For device class M, subgroups 7 and 8 tests shall be sufficient to verify the truth table. For device classes Q and V, subgroups 7 and 8 shall include verifying the functionality of the device.
- e. O/V (latch-up) tests shall be measured only for initial qualification and after any design or process changes which may affect the performance of the device. For device class M, procedures and circuits shall be maintained under document revision level control by the manufacturer and shall be made available to the preparing activity or acquiring activity upon request. For device classes Q and V, the procedures and circuits shall be under the control of the device manufacturer's TRB in accordance with MIL-PRF-38535 and shall be made available to the preparing activity or acquiring activity upon request. Testing shall be on all pins, on five devices with zero failures. Latch-up test shall be considered destructive. Information contained in JEDEC Standard EIA/JESD 78 may be used for reference.
- f. Unprogrammed devices shall be tested for programmability and ac performance compliance to the requirements of group A, subgroups 9, 10, and 11. Either of two techniques is acceptable:
 - (1) Testing the entire lot using additional built-in test circuitry which allows the manufacturer to verify programmability and ac performance without programming the user array. If this is done, the resulting test patterns shall be verified on all devices during subgroups 9, 10, and 11, group A testing in accordance with the sampling plan specified in MIL-STD-883, method 5005.
 - (2) If such compliance cannot be tested on an unprogrammed device, a sample shall be selected to satisfy programmability requirements prior to performing subgroups 9, 10, and 11. Twelve devices shall be submitted to programming (see 3.2.3.2). If more than two devices fail to program, the lot shall be rejected. At the manufacturer's option, the sample may be increased to 24 total devices with no more than 4 total device failures allowable. Ten devices from the programmability sample shall be submitted to the requirements of group A, subgroups 9, 10, and 11. If more than two devices fail, the lot shall be rejected. At the manufacturer's option, the sample may be increased to 20 total devices with no more than 4 total device failures allowable.

4.4.2 Group C inspection. The group C inspection end-point electrical parameters shall be as specified in table IIA herein. Delta limits shall apply only to subgroup 1 of group C inspection and shall consist of tests specified in table IIB herein.

4.4.2.1 Additional criteria for device class M. Steady-state life test conditions, method 1005 of MIL-STD-883:

- a. Test condition D. The test circuit shall be maintained by the manufacturer under document revision level control and shall be made available to the preparing or acquiring activity upon request. The test circuit shall specify the inputs, outputs, biases, and power dissipation, as applicable, in accordance with the intent specified in method 1005 of MIL-STD-883.
- b. $T_A = +125^{\circ}C$, minimum.
- c. Test duration: 1,000 hours, except as permitted by method 1005 of MIL-STD-883.

4.4.2.2 Additional criteria for device classes Q and V. The steady-state life test duration, test condition and test temperature, or approved alternatives shall be as specified in the device manufacturer's QM plan in accordance with MIL-PRF-38535. The test circuit shall be maintained under document revision level control by the device manufacturer's TRB in accordance with MIL-PRF-38535 and shall be made available to the acquiring or preparing activity upon request. The test circuit shall specify the inputs, outputs, biases, and power dissipation, as applicable, in accordance with the intent specified in method 1005 of MIL-STD-883.

STANDARD MICROCIRCUIT DRAWING DEFENSE SUPPLY CENTER COLUMBUS COLUMBUS, OHIO 43218-3990	SIZE A		5962-92155
		REVISION LEVEL A	SHEET 13

TABLE IIA. Electrical test requirements. 1/ 2/ 3/ 4/ 5/ 6/ 7/ 8/

Line No.	Test requirements	Subgroups (in accordance with MIL-STD-883, method 5005, table I)	Subgroups (in accordance with MIL-PRF-38535, method 5005, table III)	
		Device class M	Device class Q	Device class V
1	Interim electrical parameters (see 4.2)			1,7,9 or 2, 8A, 10
2	Static burn-in I and II (method 1015)	Not required	Not required	Required
3	Same as line 1			1*,7* Δ
4	Dynamic burn-in (method 1015)	Required	Required	Required
5	Same as line 1			1*,7* Δ
6	Final electrical parameters (programmed devices)	1*,2,3,7*, 8A,8B,9,10, 11	1*,2,3,7*, 8A,8B,9,10, 11	1*,2,3,7*, 8A,8B,9,10, 11
6A	Final electrical parameters (unprogrammed devices)	1*,2,3,7*, 8A,8B	1*,2,3,7*, 8A,8B	1*,2,3,7*, 8A,8B
7	Group A test requirements	1,2,3,4**,7, 8A,8B,9,10, 11	1,2,3,4**,7, 8A,8B,9,10, 11	1,2,3,4**,7, 8A,8B,9,10, 11
8	Group C end-point electrical parameters	2,3,7, 8A,8B	1,2,3,7, 8A,8B Δ	1,2,3,7, 8A,8B,9,10,11 Δ
9	Group D end-point electrical parameters	2,3, 8A,8B	2,3, 8A,8B	2,3, 8A,8B
10	Group E end-point electrical parameters	1,7,9	1,7,9	1,7,9

- 1/ Blank spaces indicate tests are not applicable.
- 2/ Any or all subgroups may be combined when using high-speed testers.
- 3/ Subgroups 7 and 8 functional tests shall verify the truth table.
- 4/ * indicates PDA applies to subgroup 1 and 7.
- 5/ ** see 4.4.1c.
- 6/ Δ indicates delta limit (see table IIB) shall be required where specified, and the delta values shall be computed with reference to the previous interim electrical parameters (line 1).
- 7/ See 4.6.
- 8/ See 4.4.1e

STANDARD MICROCIRCUIT DRAWING DEFENSE SUPPLY CENTER COLUMBUS COLUMBUS, OHIO 43218-3990	SIZE A		5962-92155
		REVISION LEVEL A	SHEET 14

TABLE IIB. Delta limits at +25°C.

Test <u>1/</u>	Device types
	All
I _x	±10% of specified value in table I
I _{oz}	±10% of specified value in table I

1/ The above parameter shall be recorded before and after the required burn-in and life tests to determine the delta.

4.4.3 Group D inspection. The group D inspection end-point electrical parameters shall be as specified in table IIA herein.

4.4.4 Group E inspection. Group E inspection is required only for parts intended to be marked as radiation hardness assured (see 3.5 herein).

- a. End-point electrical parameters shall be as specified in table IIA herein.
- b. For device classes Q and V, the devices or test vehicle shall be subjected to radiation hardness assured tests as specified in MIL-PRF-38535 for the RHA level being tested. For device class M, the devices shall be subjected to radiation hardness assured tests as specified in MIL-PRF-38535, appendix A for the RHA level being tested. All device classes must meet the postirradiation end-point electrical parameter limits as defined in table I at T_A = +25°C ±5°C, after exposure, to the subgroups specified in table IIA herein.

4.5 Programming procedure. The programming procedures shall be as specified by the device manufacturer and shall be made available upon request.

4.6 Delta measurements for device class Q and V. Delta measurements, as specified in table IIA, shall be made and recorded before and after the required burn-in screens and steady-state life tests to determine delta compliance. The electrical parameters to be measured, with associated delta limits are listed in table IIB. The device manufacturer may, at his option, either perform delta measurements or within 24 hours after burn-in perform final electrical parameter tests, subgroups 1, 7, and 9.

5. PACKAGING

5.1 Packaging requirements. The requirements for packaging shall be in accordance with MIL-PRF-38535 for device classes Q and V or MIL-PRF-38535, appendix A for device class M.

6. NOTES

6.1 Intended use. Microcircuits conforming to this drawing are intended for use for Government microcircuit applications (original equipment), design applications, and logistics purposes.

6.1.1 Replaceability. Microcircuits covered by this drawing will replace the same generic device covered by a contractor prepared specification or drawing.

6.1.2 Substitutability. Device class Q devices will replace device class M devices.

6.2 Configuration control of SMD's. All proposed changes to existing SMD's will be coordinated with the users of record for the individual documents. This coordination will be accomplished using DD Form 1692, Engineering Change Proposal.

6.3 Record of users. Military and industrial users should inform Defense Supply Center Columbus (DSCC) when a system application requires configuration control and which SMD's are applicable to that system. DSCC will maintain a record of users and this list will be used for coordination and distribution of changes to the drawings. Users of drawings covering microelectronic devices (FSC 5962) should contact DSCC-VA, telephone (614) 692-0544.

STANDARD MICROCIRCUIT DRAWING DEFENSE SUPPLY CENTER COLUMBUS COLUMBUS, OHIO 43218-3990	SIZE A		5962-92155
		REVISION LEVEL A	SHEET 15

6.4 Comments. Comments on this drawing should be directed to DSCC-VA , Columbus, Ohio 43218-3990, or telephone (614) 692-0547.

6.5 Abbreviations, symbols, and definitions. The abbreviations, symbols, and definitions used herein are defined in MIL-PRF-38535 and MIL-HDBK-1331 and herein:

- C_{IN}..... Input terminal capacitance.
- C_{OUT}..... Output terminal capacitance.
- GND..... Ground zero voltage potential.
- I_{CC}..... Supply current.
- I_{IX}..... Input current.
- I_{OZ}..... Output current
- T_C..... Case temperature.
- V_{CC}..... Positive supply voltage.

6.6 Sources of supply.

6.6.1 Sources of supply for device classes Q and V. Sources of supply for device classes Q and V are listed in QML-38535. The vendors listed in QML-38535 have submitted a certificate of compliance (see 3.6 herein) to DSCC-VA and have agreed to this drawing.

6.6.2 Approved sources of supply for device class M. Approved sources of supply for class M are listed in MIL-HDBK-103. The vendors listed in MIL-HDBK-103 have agreed to this drawing and a certificate of compliance (see 3.6 herein) has been submitted to and accepted by DSCC-VA.

STANDARD MICROCIRCUIT DRAWING DEFENSE SUPPLY CENTER COLUMBUS COLUMBUS, OHIO 43218-3990	SIZE A		5962-92155
		REVISION LEVEL A	SHEET 16

STANDARD MICROCIRCUIT DRAWING BULLETIN

DATE: 06-08-09

Approved sources of supply for SMD 5962-92155 are listed below for immediate acquisition information only and shall be added to MIL-HDBK-103 and QML-38535 during the next revision. MIL-HDBK-103 and QML-38535 will be revised to include the addition or deletion of sources. The vendors listed below have agreed to this drawing and a certificate of compliance has been submitted to and accepted by DSCC-VA. This information bulletin is superseded by the next dated revision of MIL-HDBK-103 and QML-38535. DSCC maintains an online database of all current sources of supply at <http://www.dscclia.mil/Programs/Smcr/>.

Standard microcircuit drawing PIN <u>1/</u>	Vendor CAGE number	Vendor similar PIN <u>2/</u>
5962-9215501MXA	0C7V7	CY7C277-50DMB
5962-9215501MYA	0C7V7	CY7C277-50LMB
5962-9215501MZA	0C7V7	CY7C277-50KMB
5962-9215502MXA	0C7V7	CY7C277-40DMB
5962-9215502MYA	0C7V7	CY7C277-40LMB
5962-9215502MZA	0C7V7	CY7C277-40KMB

- 1/ The lead finish shown for each PIN representing a hermetic package is the most readily available from the manufacturer listed for that part. If the desired lead finish is not listed contact the vendor to determine its availability.
- 2/ Caution. Do not use this number for item acquisition. Items acquired to this number may not satisfy the performance requirements of this drawing.

Vendor CAGE
number

0C7V7

Vendor name
and address

QP Semiconductor
2945 Oakmead Village Ct.
Santa Clara, CA 95051-0812

The information contained herein is disseminated for convenience only and the Government assumes no liability whatsoever for any inaccuracies in the information bulletin.