

THIS DRAWING IS UNPUBLISHED.

RELEASED FOR PUBLICATION JUNE ,2004.

REVISIONS

© COPYRIGHT 2004 By -

ALL RIGHTS RESERVED.

P	LTR	DESCRIPTION	DATE	DWN	APVD
	F	ecr-19-011875	09AUG2019	RZ	RS

NOTES

- 1 SINGLE PACK IN ACCORDANCE WITH TE SPEC 107-3275
- 2 100 TRAY PACK IN ACCORDANCE WITH TE SPEC 107-3275
- 3 Au PLATING
- 4. FOR TECHNICAL DATA REFER TO YOUR LOCAL TE CONNECTIVITY SALES OFFICE
- 5. ALL DIMENSIONS ARE NOMINAL FOR REFERENCE ONLY UNLESS OTHERWISE STATED
- 6. PACKAGING, 350/REEL X 4 = 1400 PER BOX

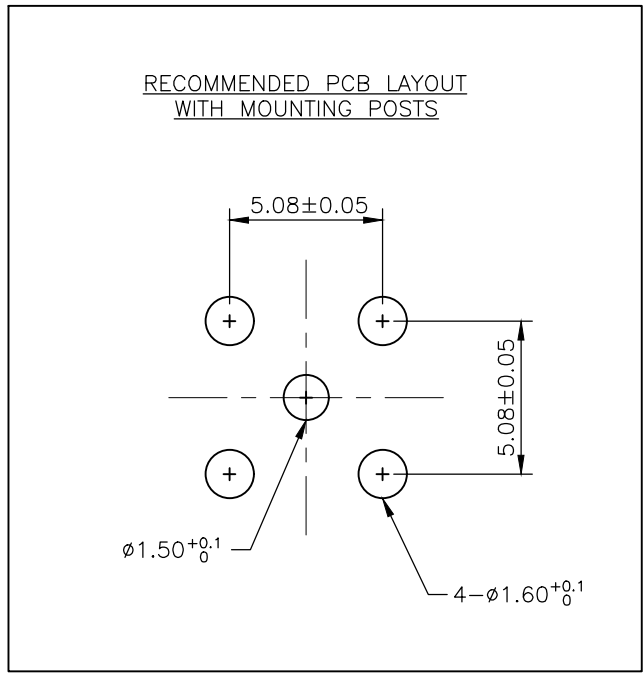
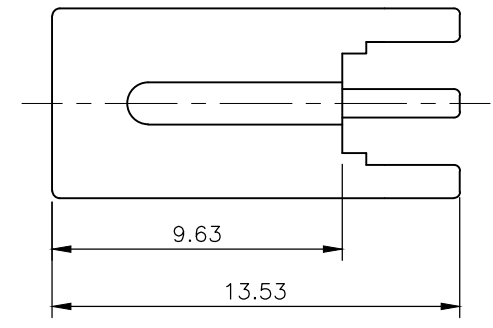
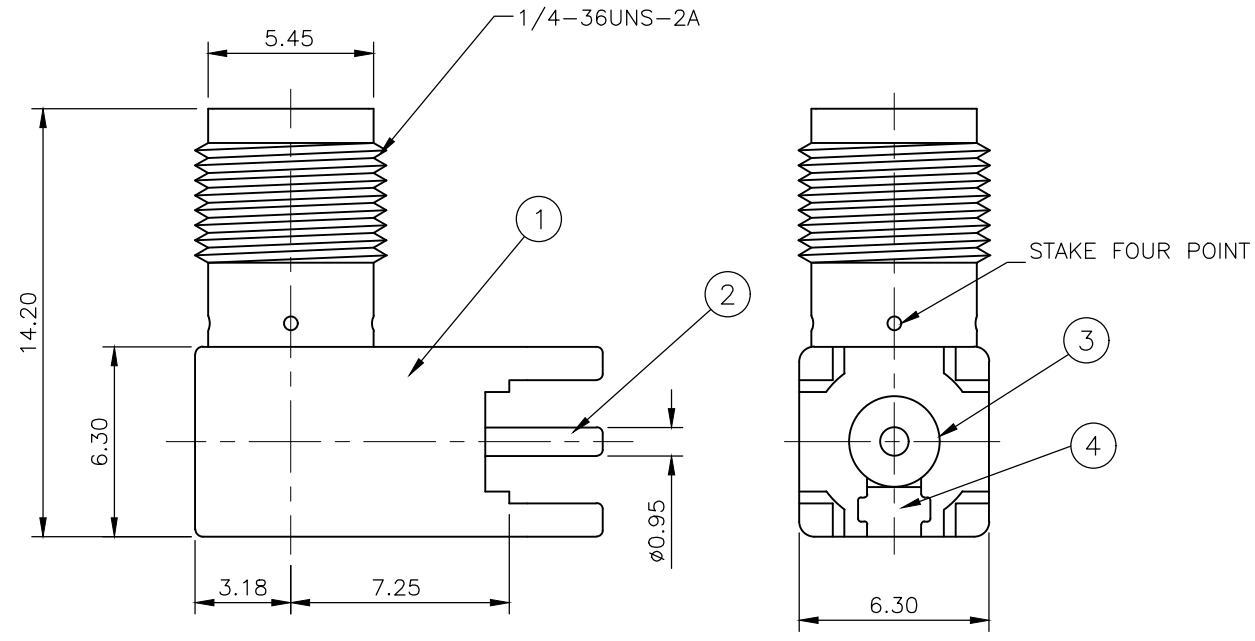

QTY	DESCRIPTION	ITEM
1	ZINC ALLOY	3 CAP
1	PTFE	3 INSULATOR
1	BERYLLIUM COPPER	3 CONTACT
1	ZINC ALLOY	3 BODY
5--25--15--0	MATERIAL	DESCRIPTION
6		ITEM

QUANTITY PER ASSY

PARTS LIST

THIS DRAWING IS A CONTROLLED DOCUMENT.

DWN ANSON MA 17MAR09
 CHK RITA ZUO 17MAR09
 APVD BOB ZHAO 17MAR09

PRODUCT SPEC 108-112000
 APPLICATION SPEC

WEIGHT 0.000000

CUSTOMER DRAWING

STE TE Connectivity

NAME SMA RIGHT ANGLE PCB SOCKET DIE CAST

SIZE A3 CAGE CODE 00779 DRAWING NO C-1814400 RESTRICTED TO

SCALE NTS SHEET 1 OF 2 REV F

THIS DRAWING IS UNPUBLISHED. RELEASED FOR PUBLICATION JUNE , 2004.
 © COPYRIGHT 2004 By - ALL RIGHTS RESERVED.

REVISIONS					
P	LTR	DESCRIPTION	DATE	DWN	APVD
-	-	SEE SHEET 1	-	-	-

FEED DIRECTION →

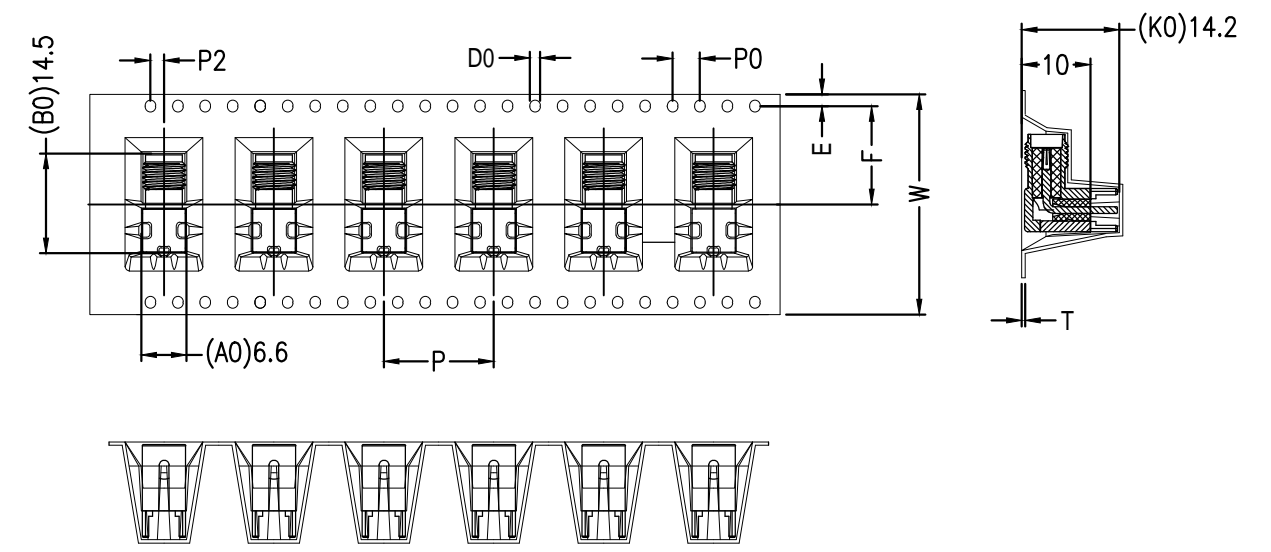
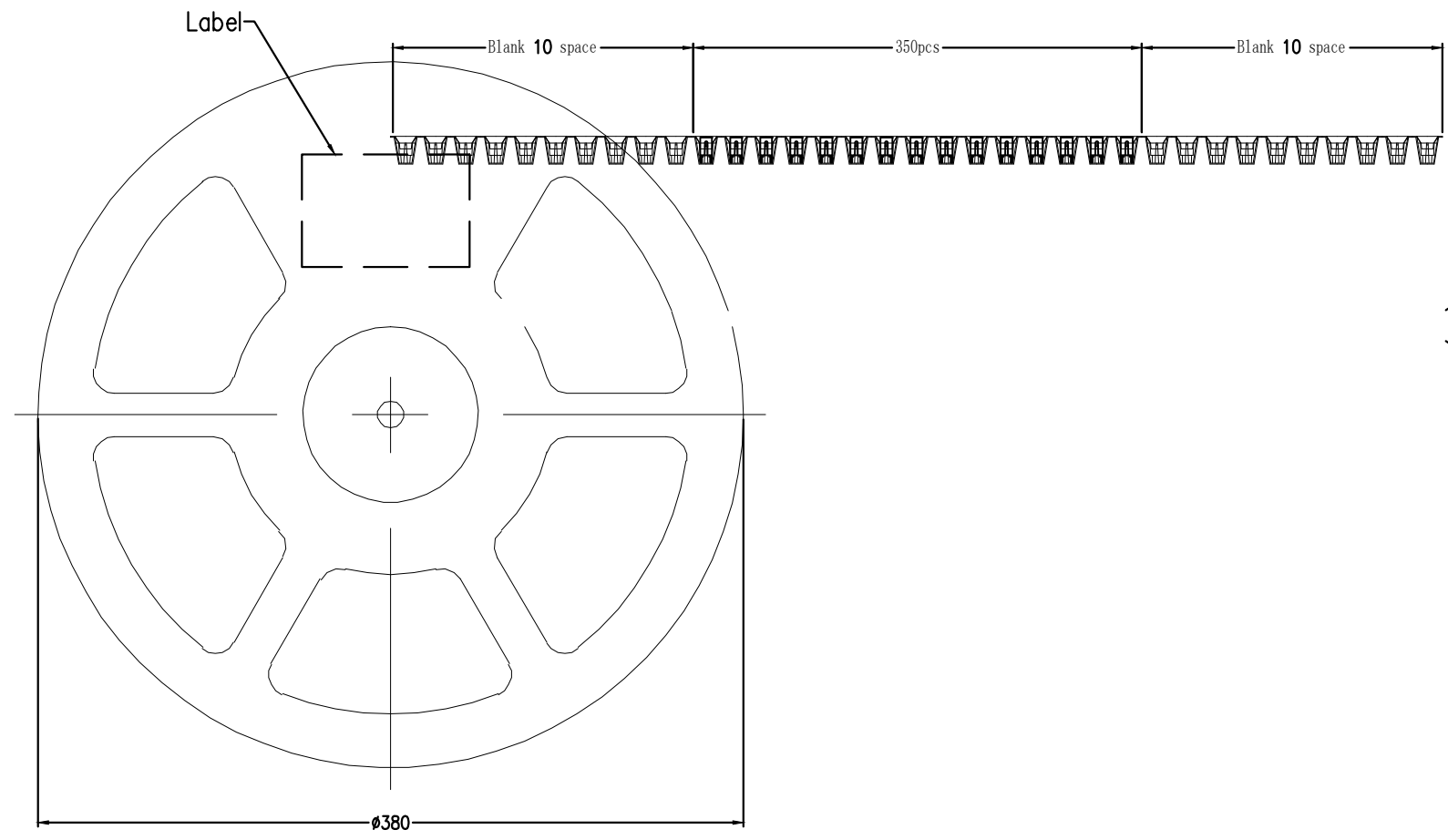
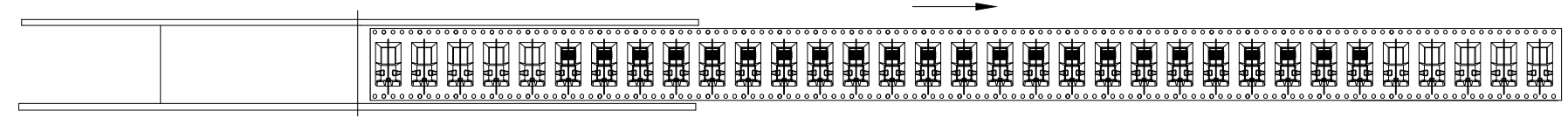

symbol	AO	BO	KO	PO	P	P2
Spec	6.60±0.10	14.5±0.10	14.20±0.10	4.00±0.10	16.0±0.10	2.00±0.10
symbol	W	T	E	F	DO	
Spec	32.0±0.30	0.50±0.05	1.75±0.10	14.2±0.10	1.50±0.10	

THIS DRAWING IS A CONTROLLED DOCUMENT.		DWN ANSON MA 17MAR09	TE Connectivity				
DIMENSIONS: mm		CHK RITA ZUO 17MAR09					
TOLERANCES UNLESS OTHERWISE SPECIFIED:		APVD BOB ZHAO 17MAR09	NAME				
0 PLC ± 0.5 1 PLC ± 0.3 2 PLC ± 0.2 3 PLC ± - 4 PLC ± - ANGLES ± -		PRODUCT SPEC 108-112000	SMA RIGHT ANGLE PCB SOCKET DIE CAST				
MATERIAL SEE TABLE		FINISH -	APPLICATION SPEC -	SIZE	CAGE CODE	DRAWING NO	RESTRICTED TO
		WEIGHT 0.000000	A3	00779	C=	1814400	-
CUSTOMER DRAWING			SCALE NTS	SHEET 2 OF 2	REV F		