

P	LTR	DESCRIPTION	DATE	DWN	APVD
1		INITIAL ISSUE	19AUG2020	SM	MZ
2		DRAFTING UPDATES	03SEP2020	SM	MZ
A		PRODUCT UNDER TESTING	24NOV2020	SM	MZ

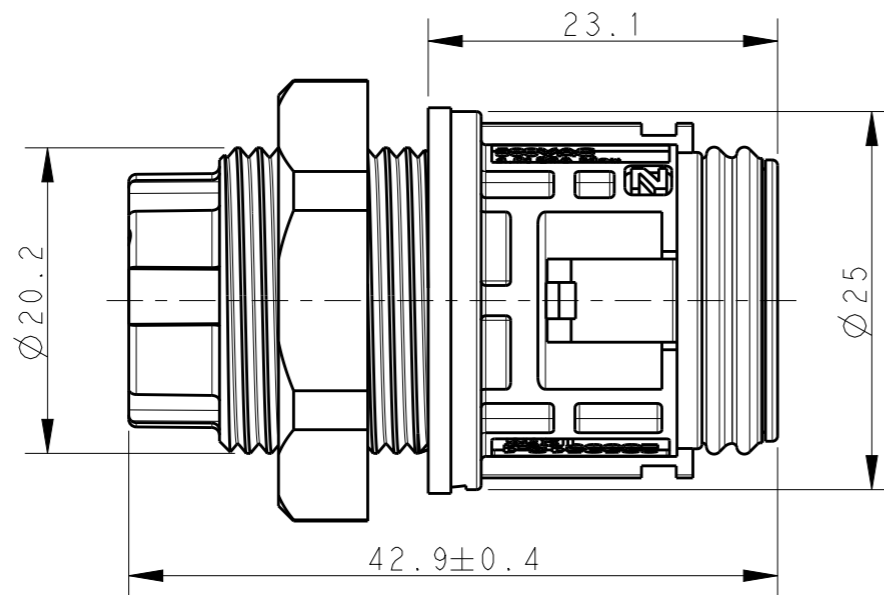

NOTES:

1. PART NUMBERS: 1-2359518-1 AND 1-2359518-2 ARE CRIMPED CONTACT VERSIONS. CONTACTS SUPPLIED SEPARATELY ON REELS, MUST PURCHASED ACCORDING TO WIRE SIZES. BELOW ARE THE CONTACT PART NUMBERS:

CONTACT P/N	WIRE SIZE
2359528-1	1.5mm ² TO 2.5mm ² 16AWG TO 14AWG
2359528-2	2.5mm ² TO 4.0mm ² 14AWG TO 12AWG

- MATERIALS:
PLASTICS: PBT+PC ALLOY, UL-V0, UV-F1
CONTACTS: COPPER ALLOY, TIN PLATED
SCREWS : STAINLESS STEEL
- OPERATING RATINGS :
VOLTAGE (max): 600Vac Max
CURRENT (max): 25A ON 4.0mm² & 20A ON 12AWG
TEMPERATURE : -40°C TO 85°C
IP RATING : IP67 & IP68
- FOR ASSEMBLY INSTRUCTIONS, REFER APPLICATION SPECIFICATION 114-133123
- PACKAGING: MOQ 200 pcs IN PE BAG

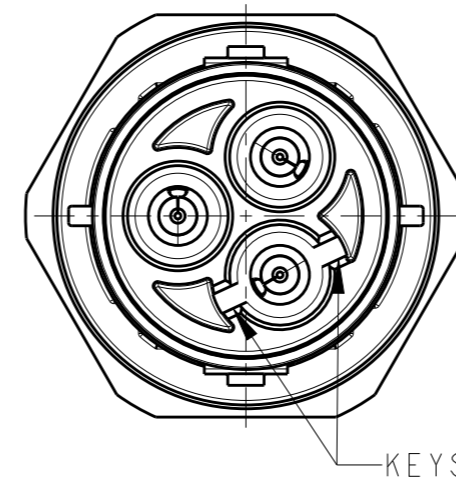
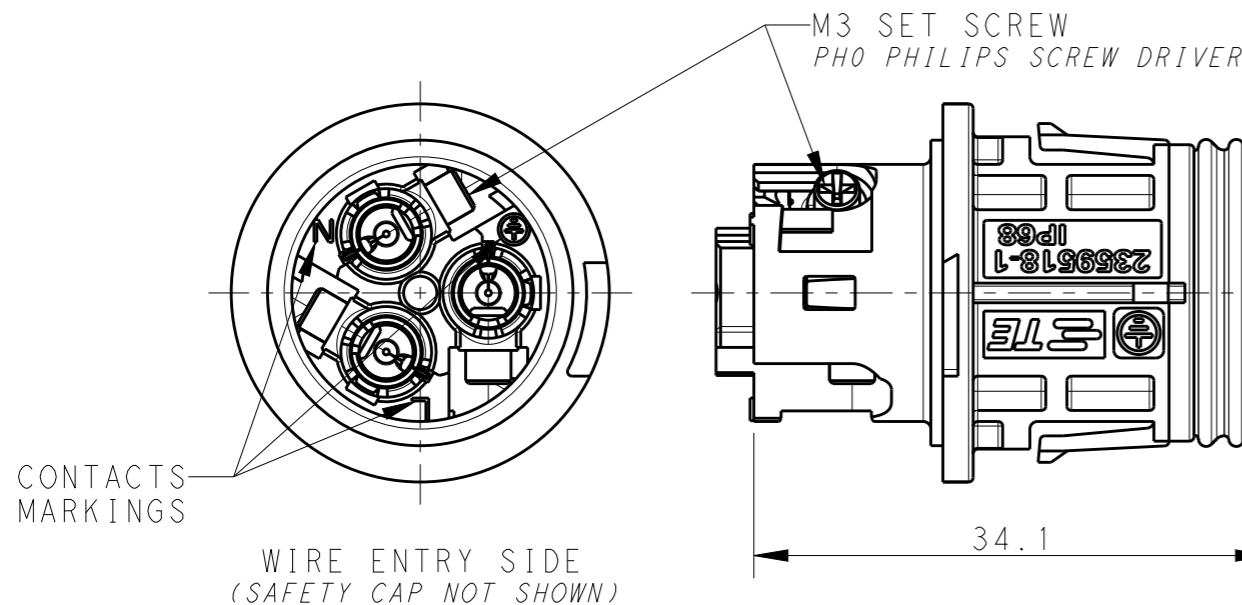

PANEL CUT-OUT RECOMMENDED SIZE

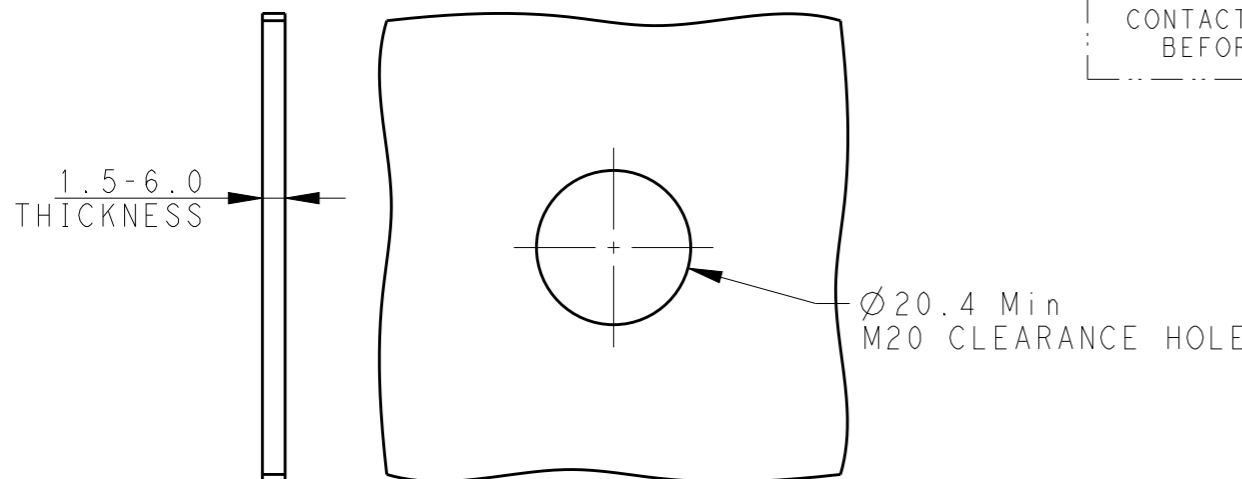

PRODUCT UNDER TESTING

CONTACT PRODUCT ENGINEERING BEFORE USING THIS PRINT

KEY B	CRIMP		1-2359518-2
KEY A		PANEL MOUNT	1-2359518-1
KEY B	SCREW	PIN CONNECTOR	2359518-2
KEY A			2359518-1
POLARIZING KEY	TERMINATION TYPE	DESCRIPTION	PART NUMBER

THIS DRAWING IS A CONTROLLED DOCUMENT.

DWN	19AUG2020	TE Connectivity	NAME NECTOR T, 3Pos, PIN CONNECTOR PANEL MOUNT		
CHK	SUBHASH.M 03SEP2020				
APVD	M. ZUCCA 24NOV2020				
PRODUCT SPEC	PETER OTT				
	108-133123	SIZE	CAGE CODE	DRAWING NO	RESTRICTED TO
	114-133123	A3	00779	C-2359518	-
MATERIAL	FINISH	CUSTOMER DRAWING	SCALE	SHEET	REV
-	-		2:1	1 OF 2	A

CRIMP TERMINATION TYPE
 1-2359518-1 & 1-2359518-2
 REFER 114-133123 FOR DETAILED INSTRUCTION

P	LTR	DESCRIPTION	DATE	DWN	APVD
-		SEE SHEET 1	-	-	-

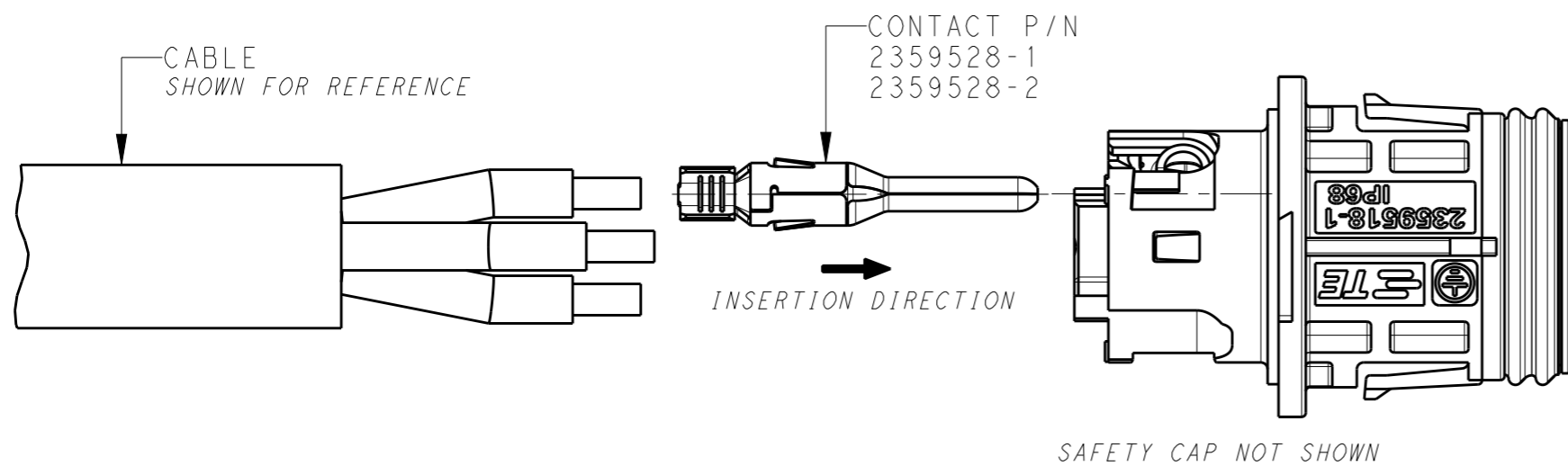

EXPLODED COMPONENTS

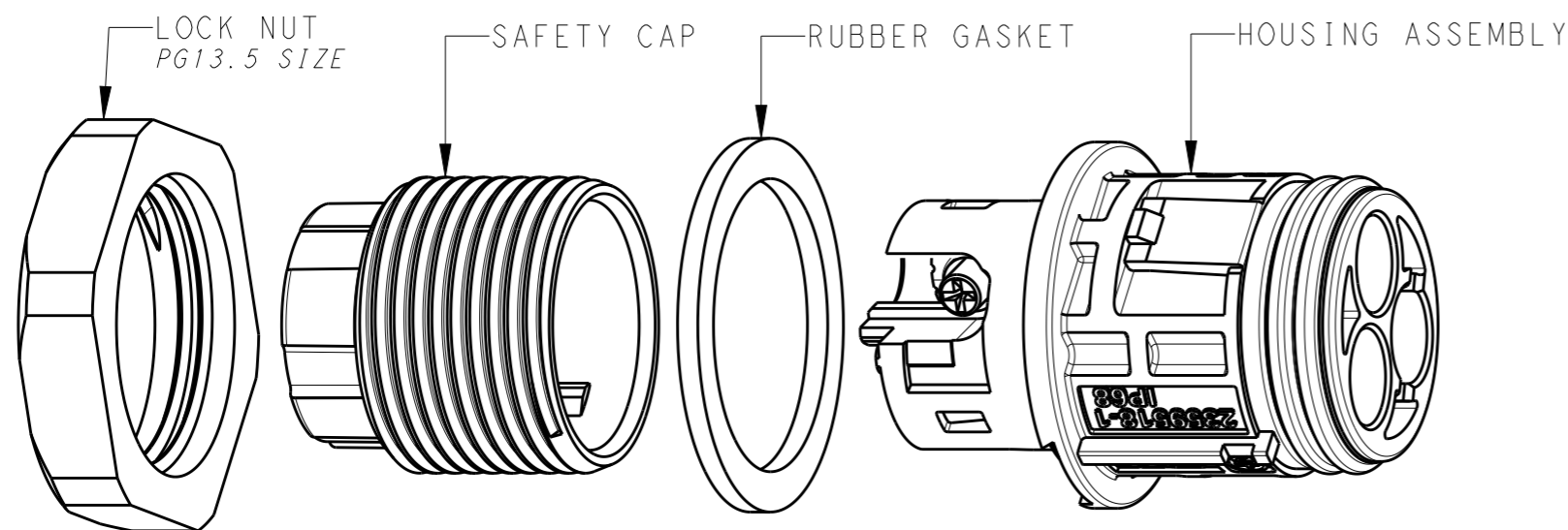

POLARIZING KEY A
 2359518-1
 1-2359518-1

POLARIZING KEY B
 2359518-2
 1-2359518-2

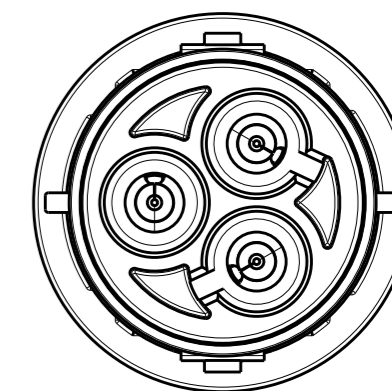
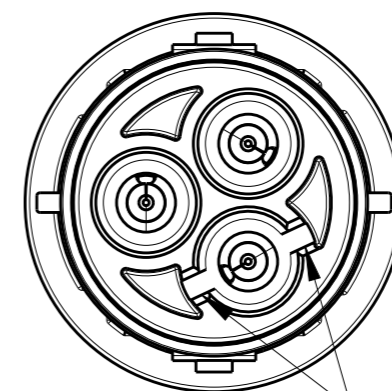

KEYS

THIS DRAWING IS A CONTROLLED DOCUMENT.		DWN SUBHASH.M 19AUG2020	TE Connectivity				
DIMENSIONS: mm		CHK M. ZUCCA 03SEP2020					
TOLERANCES UNLESS OTHERWISE SPECIFIED:		APVD PETER OTT 24NOV2020	NAME NECTOR T, 3Pos, PIN CONNECTOR PANEL MOUNT				
0 PLC ±0.2 1 PLC ±0.2 2 PLC ±0.1 3 PLC ± 4 PLC ± ANGLES ±1°		PRODUCT SPEC 108-133123	SIZE A3	CAGE CODE 00779	DRAWING NO C-2359518	RESTRICTED TO -	
MATERIAL -		FINISH -	WEIGHT -	SCALE 2:1		SHEET 2 OF 2	REV A
		CUSTOMER DRAWING					